

NOTES:

1. FOUR (4) CURB WRAP CORNERS WILL COMPLETELY FLASH A MAXIMUM CURB SIZE OF 3'X3' (90cmX 90cm). FOR LARGER CURBS USE THE TPO CURB WRAP CORNERS IN CONJUNCTION WITH ADDITIONAL SECTIONS OF SURE-WELD TPO.
2. IF CURB WRAP CORNER IS NOT USED, THEN USE DETAIL [U-15G](#) FOR OUTSIDE CORNERS.
3. REFER TO CARLISLE SPECIFICATIONS FOR ACCEPTABLE CARLISLE FASTENERS AND PLATES.
4. CUSTOM SIZES ARE AVAILABLE FOR CURB FLASHING HEIGHTS GREATER THAN 12" (30cm).

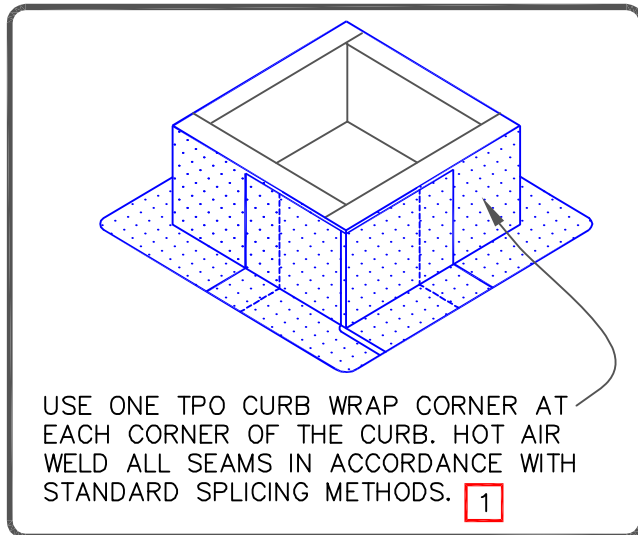

CFA (CERTIFIED FABRICATED ACCESSORIES)

	SELF-FLASHING CURB WITH CFA TPO CURB WRAP CORNERS		DETAIL NO. U-5D
	MAXIMUM WARRANTY: 30 YEARS		