

NOTES:

1. FOUR (4) CURB WRAP CORNERS WILL COMPLETELY FLASH A MAXIMUM CURB SIZE OF 3'X3' (90cmX 90cm). FOR LARGER CURBS USE THE TPO CURB WRAP CORNERS IN CONJUNCTION WITH ADDITIONAL SECTIONS OF VERSIWELD TPO.
2. IF CURB WRAP CORNER IS NOT USED, THEN USE DETAIL [TPC-15.7](#) FOR OUTSIDE CORNERS.
3. REFER TO VERSICO SPECIFICATIONS FOR ACCEPTABLE VERSICO FASTENERS AND PLATES.
4. CUSTOM SIZES ARE AVAILABLE FOR CURB FLASHING HEIGHTS GREATER THAN 12" (30cm).

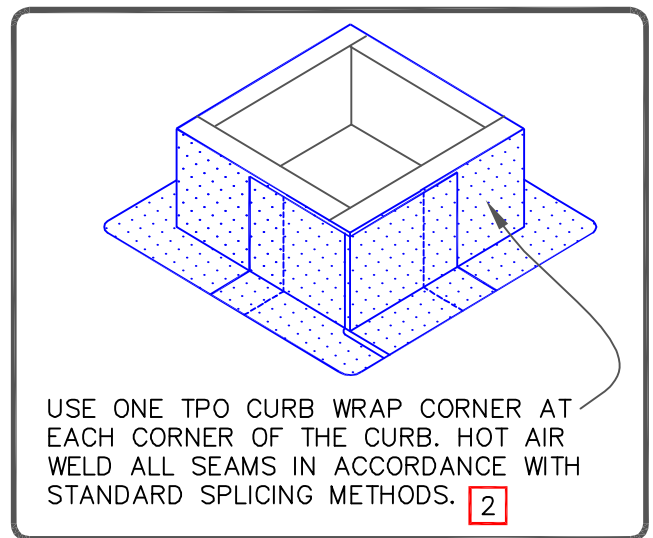

SELF-FLASHING CURB

MAXIMUM WARRANTY: 30 YEARS

- TPO MEMBRANE
- APPROVED SUBSTRATE
- 0 → SEE NOTE
- PS (PRESSURE SENSITIVE)
- P&S (PEEL & STICK)
- QA (QUICK APPLIED)

THERMOPLASTIC ROOFING SYSTEM

TPC-5.4