



X-TENDA COAT™

COATING SYSTEM

Restoration Coatings

Table of Contents

July 2024

	Page
Part I – General	
1.01 Description.....	03
1.02 Applicability.....	03
1.03 Quality Assurance.....	03
1.04 Restrictions and Exclusions.....	04
1.05 Submittals.....	05
1.06 Warranty.....	05
1.07 Job Conditions.....	06
1.08 Product Delivery, Storage and Handling.....	06
Part II - Products	
2.01 General.....	07
2.02 Coatings.....	07
2.03 Primers.....	09
2.04 Other X—Tenda Coat Products.....	13
2.05 Equipment.....	14
2.06 Granules.....	15
2.07 Other Related Products.....	15
Part III – Execution	
3.01 General.....	15
3.02 Surface Inspection.....	16
3.03 Substrate Preparation.....	16
3.04 Surface Repair & Detail Work.....	17
3.05 Coating Application.....	17
3.06 Clean Up.....	18
3.07 Roof Walkways.....	18
Attachment I – Assessment and Investigation.....	20
Attachment II – Specification Substrate Preparations – Asphaltic Roofing.....	23
Attachment III – Specification Substrate Preparations – Metal Roofing.....	27
Attachment V – Specification Substrate Preparations – Single Ply Membranes (EPDM, TPO and PVC).....	33
Application Details.....	37

Note: In addition to information listed in this section Specifiers and Authorized applicators should reference Spec Supplement and Design Reference Sections for other pertinent information.



X-TENDA COAT™

COATING SYSTEM

Restoration Coatings

July 2022

This Specification section and associated attachments represent Versico's requirement for restoration of various existing roofing systems with the X-Tenda Coat coatings and accessories.

A thorough investigation of the existing roof must be performed by a qualified representative of the building owner. The investigation is to assess the condition of the roof and to determine any needed repairs prior to commencing the restoration work. The Versico Authorized applicator shall assess the condition of the roof surface to determine the level of preparation and repairs needed. The contractor shall also perform various peel/adhesion testing to determine whether the use of primers will be required.

PART I GENERAL

1.01 Description

This restoration system utilizes the application of Versico X-Tenda Coat XTRA Silicone or X-Tenda Coat Acrylic coatings after thoroughly preparing the existing roof surface to receive the new coating. An initial assessment is performed by the Authorized Applicator to evaluate the condition of the roof surface and perform adhesion tests to determine the cleaning and priming requirements. After preparation of the existing roof surface, the coating is applied to achieve the desired dry film thickness and Versico's warranty requirements. Refer to the table in the warranty 1.06 for the total minimum dry film thickness and the warranty duration.

1.02 Applicability

- A. The restoration coating is intended to enhance and extend the service life of an existing sound and watertight roof or those that may experience occasional minor leaks. The system is not suitable for the restoration of roofs which have exceeded or are approaching the end of their service life and require substantial repair.
- B. The assessment and examination of the existing roof surface to be restored shall be performed by the Versico authorized roofing applicator and/or Versico technical representative. The assessment and examinations shall focus on the condition of the roof, surface preparation required and the components to be restored.
- C. When in-depth investigation is needed to assess the entire existing roof system, a roof consultant or qualified representative shall be obtained by the building owner to conduct such investigation. The investigation will identify all necessary system repairs prior to commencing restoration work.

1.03 Quality Assurance

- A. Moisture surveys are strongly recommended, when moisture entrapment is suspected, on roofs installed over vapor barriers, or existing membranes that may have experienced a leak.

- B. Initial sampling and core cuts may be collected by the authorized applicator or a Versico Authorized Applicator for moisture analysis. Detailed moisture surveys may be conducted by a qualified third-party using IR scans, nuclear scans or by taking core cuts.
- C. For adhesion and core cut tests there is a minimum of 3 adhesion/cut test areas that are required per 10,000 sq. ft. area with additional adhesion/cut test area recommended for every additional 10,000 sq. ft. of roofing.
- D. During the initial roof inspection by the Versico Authorized Applicator, adhesion tests are required to assess the adhesion of the coating and to determine the extent of preparation work needed for the surface. The adhesion test is performed after the surface is entirely cleaned. A minimum value of 2 (pounds per linear inch) should be the target otherwise additional cleaning and priming may be required. Consult with Versico representative for additional recommendations
- E. When inspecting an existing gravel built-up roof surface, a small sample (1/2-1") of the asphaltic surface shall be immersed in a clear glass bottle containing Isopropyl alcohol. After shaking vigorously, the liquid in the bottle should be observed for any discoloration.
 - 1. If discoloration is detected, then the sample is asphalt.
 - 2. If the liquid remains clear it indicates that the sample is coal tar.

Note: The coating restoration system is not intended for use on coal tar pitch roofs.

- F. When applying the coating restoration system over asphaltic roofs, modified bitumen, or a cap sheet, the use of X-Tenda Coat Asphaltic BB primer is strongly recommended even if an adhesion test yields acceptable values.
 - 1. For asphaltic roofs, X-Tenda Coat Asphaltic BB primer will help prevent bleed through and the possible staining of the new coating.

1.04 Restrictions and Exclusions

- A. This restoration coating system is not suitable over roofs with severely ponded conditions or those which are nearing the end of their service life and require substantial repairs.
- B. Do not apply this restoration system on roofs which have become severely crazed and brittle. Widespread cracks, punctures, blistering, and tears scattered through the roof are deemed unacceptable and the roof shall not be restored using this system.
- C. Metal roofs with severe rust or panel deflections are not restorable. The severely rusted/deflective panels must be removed and replaced. Small areas of surface rust can be treated as outlined in the Attachment III "Substrate Preparations – Metal Roofing".
- D. Roofs which have sustained severe wind or hail damage cannot be restored unless thoroughly investigated by a qualified consultant, hired by the building owner, and the roofs have been repaired and returned to serviceable condition.
- E. Existing roofs with moisture entrapment or large delaminated areas must be investigated by a qualified roof consultant and the roof returned to a serviceable condition.
- F. Ballasted roof systems are generally not suitable for restoration coating systems

1.05 Submittals

- A. When a Versico X-Tenda Coat restoration system warranty is considered, the Authorized Applicator shall contact Versico representative for a project evaluation and submit to Versico a completely executed “request for roofing warranty” along with:
 - 1. Project specification
 - 2. Preinstallation pictures
 - 3. Detailed roof drawing including roof penetrations, curbs, perimeter details, drains, and saddles or crickets if applicable.
 - 4. Peel adhesion test results
- B. A completely executed “notice of completion” must be submitted to Versico to schedule the necessary inspection. The restoration work must be inspected and accepted by a Versico Field Service Representative prior to issuance of the Versico warranty, as outlined in Paragraph 1.06 “Warranty”.
- C. When a non-Versico Authorized Applicator is selected by the building owner to perform coating restoration using Versico products and accessories, such applicator must submit to Versico, building owner and their representative, the following documents at or before time of bid:
 - 1. Reference projects with contacts
 - 2. Years of experience
 - 3. Volume of restoration work completed 5 years prior to the date.
 - 4. Application to become a Versico Authorized Applicator
- D. A sample of the Versico X-Tenda Coat Restoration Coating warranty should be made available for review by the building owner.

1.06 Warranty

- A. A **Restoration System Warranty** that covers labor and material is available for the Versico X-Tenda Coat restoration coating system for projects on commercial buildings with an existing Versico Roofing System and applies to products manufactured or marketed by Versico or products by others which may include metal, modified bitumen, smooth BUR, concrete, and single-ply membranes. Subject to the terms, conditions and limitations listed on the warranty, Versico will repair any leak resulting from material and/or workmanship deficiency, for the duration of the warranty period.
 - 1. The duration of the **Restoration System Warranty** may be 10, 15, or 20-years of coverage, depending on the dry mil thickness of the coating. See Table below.
- B. A **Restoration Material Warranty** is available for the Versico X-Tenda Coat for projects on commercial buildings and applies to products manufactured or marketed by Versico or products by others which may include metal, modified bitumen, smooth BUR, concrete, and single-ply membranes. Subject to the terms, conditions and limitations listed on the warranty, Versico will provide repair material if the coating prematurely deteriorates to the point of failure because of weathering for the duration of the warranty period.

the dry mil thickness of the coating. See Table below.

C. All X-Tenda Coat warranties are separate from existing Versico Roof System Warranties

Warranty Duration	Minimum Dry Film Mil Thickness			
	Silicone Coatings		Acrylic Coatings	
	Granulated Cap Sheet	All Other Substrates	Granulated Cap Sheet	All Other Substrates
5 Year	22 mils	15 mils	23 mils	18 mils
10 Year	30 mils	22 mils	31 mils	26 mils
15 Year	37 mils	30 mils	36 mils	31 mils
20 Year	44 mils	37 mils	44 mils	40 mils

Note: Contact Versico for other available coatings

D. Access for Warranty Service

It shall be the owner’s responsibility to expose the roof system in the event that warranty service is required when access is impaired. Such impairment includes, but is not limited to:

1. Design features, such as window washing systems, which require the installation of traffic surface units in excess of 80 pounds per unit.
2. Any equipment, ornamentation, building service units and other top surfacing materials which are not defined as part of this specification.
3. Photovoltaic and Mounting Systems or other Rooftop equipment that do not provide Versico with reasonable access to the roofing system for the purposes of warranty investigation and related repairs.

CAUTION: Applications such as walking decks, terraces, patios or areas subjected to conditions not typically found on roofing systems are **not** eligible for warranties.

E. The formation or presence of mold or fungi in a building is dependent upon a broad range of factors including, but not limited to, the presence of spores and nutrient sources, moisture, temperatures, climatic conditions, relative humidity, and heating/ventilating systems and their maintenance and operating capabilities. These factors are beyond the control of Versico and Versico shall not be responsible for any claims, repairs, restoration or damages relating to the presence of any irritants, contaminants, vapors, fumes, molds, fungi, bacteria, spores, mycotoxins, or the like in any building or in the air, land, or water serving the building.

1.07 Job Conditions

- A. Prior to application of the coating, the applicable PDS shall be referenced to identified surface temperature limitations based on coating system to be utilized. The service temperature of any surface to be coated shall not exceed 180°F (82°C).
- B. Moisture in the form of rain, fog, frost, dew may adversely affect the coating and adhesion. Do not apply coating when these conditions exist.
- C. To prevent surface contamination from coating overspray, mask areas where coating is to be terminated.

With owner permission, seal/close ventilation intakes and protect surrounding equipment from potential overspray.

- D. Compatibility to chemical exposure will depend on type of coating used. Versico should be contacted for verification of compatibility with chemicals or specific waste products that may come in contact with the roofing system.

Caution: Surface moisture and icy conditions are not easily detected on lighter color membranes (white, tan, gray, etc.) especially those located in cold regions. The roof surface may become extremely slippery and care shall be exercised when accessing the roof in the early morning hours (dew formation), any time after rain or during the winter. The use of sunglasses is strongly recommended when reflective coatings are used as the final coat.

1.08 Product Delivery, Storage and Handling

- A. Deliver materials to the site in their original, tightly sealed containers, all clearly labeled with manufacturer’s name, product identification and lot number.
- B. Safely store materials in their original containers out of the weather, keep dry and within the temperature limits specified by the manufacturer. Refer to specific product PDS for storage requirements.
- C. All materials shall be stored in compliance with applicable fire and safety requirements.
- D. Protect materials from damage during transit, handling, storage and application.
- E. If loading materials onto the roof, the Versico Authorized Roofing Applicator must comply with the requirements of the specifier/owner to prevent overloading and possible disturbance to the building structure.

PART II PRODUCTS

2.01 General

The product components of this Versico X-Tenda Coat Restoration Coating System are composed of Versico products or those accepted by Versico as compatible with this roofing system. The installation, performance or integrity of products by others, **when selected by the specifier and accepted as compatible**, is not the responsibility of Versico and is expressly disclaimed by the Versico Warranty.

2.02 Coatings

Table 1

Available Coatings	
X-Tenda Coat XTRA Silicone Coating	X-Tenda Coat Acrylic Coating
X-Tenda Coat XTRA Silicone	X-Tenda Coat Acrylic Top Coat

	X-Tenda Coat Acrylic Base Coat
	X-Tenda Coat Acrylic Bleed Block Base Coat

Note- Contact Versico for additional products and accessories

A. X-Tenda Coat XTRA Silicone Coating

X-Tenda Coat XTRA Silicone Roof Coating is a 100% silicone, high solids, solvent-free, one-component, moisture-curing silicone rubber roof coating system for use on existing smooth asphaltic BUR, smooth or granulated cap sheets, single-ply roof membrane, well adhered acrylic coating, metal, concrete, sprayed-in-place polyurethane foam, and various types of aged membrane roofing. The system provides long-term weathering protection and resists the effects of ozone, ultraviolet radiation, and temperature extremes. With its high solids content and absence of hydrocarbon solvents, X-Tenda Coat XTRA can be applied in excess of 50 mils in a single coat without blistering, while maintaining maximum adhesion.

Note: Table 2 shows the physical properties for X-Tenda Coat XTRA silicone coating.

Table 2

Physical Property	Test Method	X-Tenda Coat XTRA - Silicone Coating
Volatile Organic Content (VOC), (g/l)	EPA Method 24	<50
Tensile Strength, die C, psi	ASTM D 412	320 PSI
Elongation at break, %	ASTM D 412	280%
Permeability, perms	ASTM E 96B	4.6
Solar Reflectivity (White)	ASTM C 1549	0.84 (3 year aged) 0.87 (initial)
Emissivity (White)	ASTM C 1371	0.9 (3 year aged) 0.9 (initial)
Solar Reflectance Index (SRI) (White)	ASTM E 1980	110
Low Temperature Flexibility	ASTM D 522 Method B	-15°F (-26.1°C) Pass
Solids Content by Volume %	ASTM D 2697	92±3
Shelf Life		2 years

B. X-Tenda Coat Acrylic Coatings

1. X-Tenda Coat Acrylic Top Coat

X-Tenda Coat Classic Acrylic Top Coat is a high-quality, acrylic, elastomeric coating for all substrates including asphalt, single-ply, spray polyurethane foam (SPF), metal, and concrete roofing systems. X-Tenda Coat Classic Acrylic Top Coat has optimum adhesion to SPF.

2. X-Tenda Coat Acrylic Base Coat

X-Tenda Coat Classic Single-Ply Base Coat is a one-component, low-VOC, water-borne base coating designed for application to aged single-ply roofing membranes. X-Tenda Coat Classic Single-Ply Base

Coat is the industry standard, high-performance base coat for hard-to-coat surfaces such as aged Hypalon®, PVC, TPO, and EPDM roofing. X-Tenda Coat Classic Single-Ply Base Coat eliminates the need for costly replacement and pre-treating EPDM with a caustic solution before the coating is applied.

3. X-Tenda Coat Acrylic Bleed Block Base Coat

X-Tenda Coat Acrylic Bleed Block Base Coat is a multi-purpose, acrylic, elastomeric coating for use over a variety of substrates including asphalt and metal roofing. It has unique “bleed blocking” properties that make it particularly suited for coating over asphalt surfaces and exceeds several ASTM D6083 requirements for critical properties such as tensile strength, elongation, wet adhesion and weatherability.

Refer to Table 1 for available types of coatings.

Table 3

Physical Property	Test Method	Top Coat	Base Coat	Bleed Block Base Coat
Tensile Strength, psi	ASTM D 2370	265		270
% Elongation	ASTM D 2370	240		260
Volume Solids, %	ASTM D 2697	54 ±2	54 ±2	52±2
Weight Solids, %	ASTM D 1644	68±1	67±2	66±2
Permeance, perms	ASTM D 1653B	18		12
Solar Reflectivity (Initial)	ASTM C 1549	0.84		
Solar Reflectance Index (SRI) (White)	ASTM E 1980	106		
Drying Time		Recoat 12-24 hrs Tack Free 2-12 hrs	Recoat 12-24 hrs Tack Free 2-12 hrs	Recoat 12-24 hrs Tack Free 2-12 hrs
Shelf Life		2 years	2 years	2 years

2.03 Primers

A. X-Tenda Coat Metal Primer

X-Tenda Coat Metal Primer is a single-component acrylic primer that is stain resistant, permanently flexible, and very durable. It has excellent resistance over metal substrates and works very well over concrete, masonry, and wood substrates as well. X-Tenda Coat Metal Primer can be over-coated with acrylic and silicone coating systems. The product dries/cures quickly and has weather resistant characteristics and extended open time for easy, high-quality applications. It is designed to provide resistance to corrosion and excellent adhesion to steel, aluminum, and galvanized metal substrates.

Table 4

Physical Property	Test Method	X-Tenda Coat Metal Primer
Solids Content by Weight, %	ASTM D 2369	45 ±2
Solids Content by Volume, %	ASTM D 2697	37 ±2
Density, lbs/gal	ASTM D 1475	9.8 lbs./gal.
VOC, g/l	EPA Method 24	<100

Cure Time @ 75°F		Dry to touch 20-40 minutes Full cure within 24 hours
Shelf Life		1.5 years

B. X-Tenda Coat Asphaltic BB Primer

X-Tenda Coat Asphaltic BB Primer is a one-component, water-based elastomeric base coating and sealer that is highly resistant to disbonding and prohibits passage of asphaltic oils from existing asphalt roof materials.

Table 5

Physical Property	Test Method	X-Tenda Coat Asphaltic BB Primer
Solids Content by Volume, %	ASTM D 2697	>48%
Weight per Gallon, lbs/gal	ASTM D 1475	10.5-11.4 lbs.
VOC Content (Maximum), g/l	EPA Method 24	50 g/l
Cure Time		Full cure within 24 hours
Shelf Life		2 years

C. X-Tenda Coat TPO Primer

X-Tenda Coat TPO Primer is a low-VOC, solvent-based primer designed to promote optimal adhesion of acrylics, silicones, and other coatings to new or existing TPO single-ply membranes. The application of X-Tenda Coat TPO Primer is simple, cost effective, and efficient. X-Tenda Coat TPO Primer is tinted to help distinguish primed areas on white TPO membranes.

Table 6

Physical Property	Test Method	X-Tenda Coat TPO Primer
Solids Content by Volume, %	ASTM D 2697	1%
VOC, g/l	EPA Method 24	<50
Cure Time		15 mins
Shelf Life		1 yr

General Product Limitations

Protect from freezing during shipping and storage. Do not apply primer or coatings when it is raining or if the threat of rain exists. Do not apply when the dew point is less than 5°F above ambient temperature. Subsequent coats should be applied within 48 hours of prior applications to ensure full and uniform adhesion. Do not use on new concrete (less than 30 days). Refer to individual PDS and SDS for specific product application, storage and handling requirements.

General Substrate Recommendations

For additional substrates, preparation or approved primers contact Versico.

Table 7

X-Tenda Coat Silicone Coating	
Roof Surface	Primer
New EPDM	N/A
Aged EPDM*	N/A
New TPO	X-Tenda Coat TPO Primer
Aged TPO*	X-Tenda Coat TPO Primer
New PVC/KEE	Contact Versico
Aged PVC/KEE*	X-Tenda Coat Asphaltic BB Primer
Hypalon®*	N/A
New Ferrous Metal, Galvanized, or Galvalume finished*	N/A
Aged Ferrous Metal, Galvanized, or Galvalume finished*	X-Tenda Coat Metal Primer
New Concrete	N/A
Aged Concrete*	N/A
New Smooth BUR	X-Tenda Coat Asphaltic BB Primer
Aged Smooth BUR*	X-Tenda Coat Asphaltic BB Primer
New APP	X-Tenda Coat Asphaltic BB Primer
Aged APP*	X-Tenda Coat Asphaltic BB Primer
New SBS - Smooth	X-Tenda Coat Asphaltic BB Primer
Aged SBS - Smooth*	X-Tenda Coat Asphaltic BB Primer
New SBS – Granulated	X-Tenda Coat Asphaltic BB Primer
Aged SBS - Granulated*	X-Tenda Coat Asphaltic BB Primer
Aged Silicone*	N/A
Aged Acrylic*	N/A

*- Field adhesion test required (2.0pli minimum)

Table 8

X-Tenda Coat Acrylic Coating	
Roof Surface	Primer
New EPDM	N/A
Aged EPDM*	N/A
New TPO	X-Tenda Coat TPO Primer
Aged TPO*	X-Tenda Coat TPO Primer

New PVC/KEE	Contact Versico
Aged PVC/KEE*	X-Tenda Coat Asphaltic BB Primer
Hypalon®*	N/A
New Ferrous Metal, Galvanized, or Galvalume finished*	N/A
Aged Ferrous Metal, Galvanized, or Galvalume finished*	X-Tenda Coat Metal Primer
New Concrete	N/A
Aged Concrete*	N/A
New Smooth BUR	X-Tenda Coat Acrylic Bleed Block Base Coat
Aged Smooth BUR*	X-Tenda Coat Acrylic Bleed Block Base Coat
New APP	X-Tenda Coat Acrylic Bleed Block Base Coat
Aged APP*	X-Tenda Coat Acrylic Bleed Block Base Coat
New SBS - Smooth	X-Tenda Coat Acrylic Bleed Block Base Coat
Aged SBS - Smooth*	X-Tenda Coat Acrylic Bleed Block Base Coat
New SBS – Granulated	X-Tenda Coat Acrylic Bleed Block Base Coat
Aged SBS - Granulated*	X-Tenda Coat Acrylic Bleed Block Base Coat
Aged Acrylic*	N/A

*- Field adhesion test required (2.0pli minimum)

2.04 Other X-Tenda Coat Products

- A. **X-Tenda Coat Acrylic Mastic** is a white, elastomeric acrylic patching compound specially formulated for repairing and preventing roof leaks prior to coating with an acrylic reflective coating. X-Tenda Coat Acrylic Mastic will not crack, craze, or lose adhesion when applied as directed to a smooth, clean, sound roof surface.
- B. **X-Tenda Coat XTRA Butter Grade Mastic** is an exceptionally versatile, tough yet flexible membrane that is easily brush or trowel-applied at thicknesses up to ¼" thick. It is also an excellent repair material for direct-to-metal (DTM) repairs, spray polyurethane foam, smooth built-up, smooth modified bitumen, granulated modified bitumen, aged single-ply roof membrane, flashings, fasteners, and drains.

Note: X-Tenda Coat XTRA Butter Grade Silicone Mastic can only be coated with X-Tenda Coat XTRA silicone coating.

- C. **X-Tenda Coat XTRA Fiber Grade Mastic** is a one-component, moisture-curing, fibrated silicone rubber roof mastic designed for use on a variety of membranes and coated roofs. The product is trowel-applied and is designed to allow high build (up to 1/2") trowel application on vertical or flat surfaces. Typical uses include rough areas of SPF, drain bowls, under and around rooftop-mounted equipment, etc. X-Tenda Coat XTRA Fiber Grade Mastic cures quickly and provides immediate waterproofing for short-term, long-term, and emergency repairs. It is also an excellent repair material for direct-to-metal (DTM) repairs, smooth built-up, smooth modified bitumen, granulated modified bitumen, aged single-ply roof membrane, flashings, fasteners, and drains.

Note: X-Tenda Coat XTRA Fiber Grade Silicone Mastic can only be coated with X-Tenda Coat XTRA silicone coating.

- D. **X-Tenda Coat XTRA Fastener Sealant** is a one-component, moisture-curing sealant designed to reduce flow and sag properties to improve the hang of the sealant on low and semi-steep sloped applications. X-Tenda Coat XTRA Fastener Sealant is used to seal fasteners on low and semi-steep sloped metal roofs by applying a dollop of sealant to each fastener head, which completely encapsulates the fastener and seals the perimeter to the metal panel. This self-leveling sealant forms a watertight seal for pipe penetrations through roof decks in metal pitch pocket flashings, with zero shrinkage. It is mold- and mildew-resistant and is easily applied in a standard cartridge.

Note: X-Tenda Coat XTRA Fastener Sealant can only be coated with X-Tenda Coat XTRA silicone coating.

- E. **X-Tenda Coat Reinforcement Fabric** is a stitchbonded, high performance fabric for use in cold applied built-up roofing and roof maintenance systems. It is white to off white with lay lines for one and two ply roof systems. It is ideal as the Reinforcement component in cold process roofing and repair using either water-based asphalt or acrylic emulsions, or solvent type coatings or mastics.

2.05 Equipment

For spray equipment considerations, please refer to SPFA-144- Coating Equipment Guideline or consult the spray equipment manufacturer directly. For additional recommendations, refer to X-Tenda Coat specific Product Data Sheet.”

2.06 Granules

Granules are optional. They may be used to enhance aesthetics, impact resistance, slip resistance or highlight walkways. Granules shall be number 11 screen size, ceramic-coated roofing granules, color to match topcoat. Quartz or silica aggregate are also acceptable. Apply at a rate of 30-40 pounds per 100 square feet.

2.07 Other Related Products

- Rollers with 1/2” Nap
- Brushes
- 1,500 to 2,000 psi rated power washer
- Detergent
- Squeegees

PART III EXECUTION

Prior to commencing with the installation of any of the X-Tenda Coat Acrylic or X-Tenda Coat XTRA Silicone Restoration Systems, refer to Paragraph 1.06 “Warranty” for applicable requirements suitable for the appropriate warranty coverage.

Requirements listed in this specification are considered minimum and are intended for the sole purpose of obtaining a Versico Restoration Warranty. Additional requirements dictated by Regulatory Agencies, Building Insurance or Specifiers must be complied with and are beyond the scope of this specification.

3.01 General

- A. Safety Data Sheets (SDS) must always be on location during transportation, storage and application of materials. The applicator shall follow all safety regulations as recommended by OSHA, and/or other agencies having jurisdiction.
- B. To ensure most current installation requirements are met, Product Data Sheets should be available on site.
- C. Comply with building owner requirement for onsite material storage and campus regulations. Place dumpster and other equipment in areas which have been designated by the building owner.
- D. The worksite must be kept in an organized and orderly fashion. All waste products must be removed and disposed of, in accordance with local ordinances.

3.02 Surface Inspection

The assessment and examination of the existing roof system to be restored shall be performed by the Versico authorized roofing applicator or Versico technical representative. The assessment and examinations shall focus on the condition of the roof surface and the components to be restored.

- A. When in-depth investigation is needed to assess the entire existing roof assembly. A roof consultant shall be obtained by the building owner to conduct such investigation. Investigation shall identify all necessary system repairs prior to commencing restoration work.
- B. If certain major repairs have been identified that required membrane removal, replacement or the addition of new insulation, such repairs must be performed with by an authorized applicator trained on the specific roof system and in accordance with manufacturer guidelines to ensure the repaired section is sound and leak free.
- C. This restoration coating system is not suitable for roofs with severe ponding conditions where water accumulates on the surface of the membrane for periods greater than 48 hours, in areas scattered across 20% of the roof. If restoration is being considered the affected areas shall be repaired to achieve positive drainage and properly sealed. Refer to appropriate attachment or product warranty for specific system repairs.

Note: Consult **Attachment I** - “Assessment and Investigation” for the applicable guidelines for assessing various roof assemblies.

3.03 Substrate Preparation

- A. Attachments II-IV, included at the end of this Restoration Coating section, contain information on the appropriate substrate preparation (cleaning, priming, and repairing), categorized by the type of the existing roof membrane.

Attachment II – “Substrate Preparation – Asphaltic Roofing”

Attachment III – “Substrate Preparation – Metal Roofing”

Attachment IV – “Substrate Preparation – Single Ply Membrane”

- B. Refer to tables 7 & 8 included in Part II for general substrate recommendations concerning cleaning and priming of the various types of roofing surfaces. Certain roofs may only require cleaning and others may require the use of cleaning and primer to enhance coating adhesion. Certain roofs may require primer in addition to cleaning to prevent staining, bleed through or inhibit the formation of surface rust. The appropriate table may be referenced as a general guide. Contact Versico for additional recommendations.

- C. For all aged substrates, adhesion tests are required, as outlined in the quality assurance article, to determine the extent of the surface treatment and the use of primers. Adhesion tests are strongly recommended on all new substrates to verify suitability of general substrate recommendations. Such testing is recommended at an earlier stage of the project, preferably prior to the bid, and may be performed during the initial roof inspection and surface assessment performed by the Authorized Applicator and/or Versico representative.
- D. Do not commence with surface repairs unless all system related issues and imperfections have been addressed by the building owner and their design representative.
- E. Clean and prepare surface to receive the restoration coating. Remove all dirt, loose and flaking particles, grease, oil, laitance, pollution fallout, and other contaminants that may interfere with proper adhesion.

Note: The use of a stiff bristle push broom and pressure washing for cleaning and surface preparations is recommended.

- F. When required, clean the existing surface with applicable cleaning solution and power-wash with clean water. The appropriate attachment at the end of this section may be referenced for specific substrate preparation requirements.

3.04 Surface Repair & Detail Work

- A. Depending on the type of roof system being restored, asphaltic, metal, or a single ply, vulnerable areas such as seams, flashing overlaps, expansion joints, vertical curbs, and other roof penetrations must be prepared to extend the watertight performance. In addition, other identified surface deficiencies such as blisters, minor splits, tears, cracks, surface rust and punctures must be prepared as outlined in the specific attachment.
- B. When performing surface treatments prior to coating, use acrylic mastic for acrylic coatings and silicone mastics for silicone coatings. All mastics and sealants must be allowed to fully cure before applying coating.
- C. In these repair locations, Reinforcement fabric imbedded into the base coat and covered with the topcoat, may be used to overlay deficient areas. After completing the necessary prep work using coating and Reinforcement fabric, or appropriate mastic, allow repaired area to cure. Curing time will vary based on temperature and humidity level. Refer to the X-Tenda Coat PDS for the acceptable cure time.
- D. Attachments II-V, included at the end of this Restoration Coating section, contains information on the appropriate surface repair and detail work, categorized by the type of the existing roof membrane.

Attachment II – “Substrate Preparation – Asphaltic Roofing”

Attachment III – “Substrate Preparation – Metal Roofing”

Attachment IV – “Substrate Preparation – Single Ply Membranes (EPDM, TPO and PVC)”

3.05 Coating Application

A. General

1. Do not apply coating if weather conditions will not permit complete cure (24-hour period) before rain, dew, fog or freezing temperatures occur.

2. Using a high-pressure compressed air or an air blower, blow all dust, dirt and other contaminants off the treated roof surfaces.
3. Apply coating when temperature is within the specified range for the specific product (consult the applicable product PDS) with no inclement weather imminent.
4. The use of brushes is recommended for delicate detail work and edges at parapets, HVAC units, stacks, skylights, penetrations, etc.
5. Sealant/mastic must be cured, clean and free of all moisture prior to application of coating.
6. Apply the coating to achieve a uniform application to equal a minimum total finished dry film thickness required in the warranty table paragraph 1.06.
7. Apply approved granules at the rate of 30-40 pounds per 100 square feet to achieve the desired surface texture. When used for walkways, the granules should be used in a contrasting color so that the walkway is visible. Refer to Section 3.07 – Walkways.
8. Allow the topcoat to cure prior to inspecting the finished surface. Repair any defects with appropriate X-Tenda Coat sealant/mastic and/or additional application of coating.

3.06 Clean up

Allow coating to dry before subjecting the surface to traffic. Drying conditions will vary depending on temperature and humidity levels. Consult the specific Product Data Sheets for estimated cure time.

- A. Walk the roof to ensure all tools are removed and lids, empty containers and other debris are picked up and properly disposed of.
- B. Check drains and air intake vents to ensure that they are open with no obstructions. Check roof perimeter and terminations. Make sure all terminations are properly sealed and all masking tape used for terminations, is removed.
- C. If spray equipment is used, ensure hoses are properly coiled and spray equipment is adequately cleaned as per manufacturer's instructions.
- D. When applicable, provide owner representative with instructions on accessing the roof following the coating application.

3.07 Roof Walkways

A. Scope of Work:

Walkways are to be specified at all traffic concentration points (i.e., roof hatches, access doors, rooftop ladders, etc.), and if regular maintenance (once a month or more) is necessary to service rooftop equipment.

B. Walkways Limitations & Cautions:

1. Factory-made walkways are considered a maintenance item and are excluded from the Versico warranty.

2. Window washing equipment will require special maintenance. Runways or window washing tracks must be segregated and separately constructed, with approved roofing or waterproofing system. When such conditions exist, it must be reviewed by Versico.

END OF SECTION

Copyright 2022 Carlisle Construction Materials Incorporated

X-Tenda Coat and Versico are Trademarks of Carlisle Construction Materials Incorporated

This Spec Supplement represents the applicable information available at the time of its publication. Owners, Specifiers and Versico authorized roofing applicators should consult CRFC or their Manufacturer's Representative for any information that has subsequently been made available.



X-TENDA COAT™

COATING SYSTEM

Restoration Coating Attachment I Assessment and Investigation

July 2022

Information contained in this attachment is intended for use as part of the Versico X-Tenda Coat Restoration Coating system. This attachment specifically pertains to the investigation and assessment of an existing roof surface to verify suitability for restoration. While this attachment only addresses investigation, information pertaining to substrate preparation, repairs, and cleaning are available in other attachments in this section.

GENERAL

The restoration coating is intended to enhance and extend the service life of an existing, sound and watertight roof or one that may experience occasional minor leaks. This system is not suitable for the restoration of roofs which have exceeded or are approaching the end of their service life.

1. The assessment and examination of the existing roof surface to be restored shall be performed by the Versico authorized roofing applicator or Versico technical representative. The assessment and examinations shall focus on the condition of the roof surface and the components to be restored.

Note: When in-depth investigation is needed to assess the entire existing roof system, a roof consultant or qualified professional shall be attained by the building owner to conduct such investigation. The investigation shall identify all necessary system repairs prior to commencing with the restoration work.

2. If certain major repairs have been identified that required membrane removal and replacement and the addition of new insulation, such repairs must be performed with an applicator, authorized and trained on the specific roof system, and in accordance with manufacturer's warranty requirements.
3. Moisture surveys are strongly recommended, when moisture entrapment is suspected, on roofs installed over vapor barriers, or over existing membranes and may have experienced a leak.
4. Moisture surveys may be conducted by a qualified third-party using IR Scans, Nuclear scans or by taking core cuts. Core cuts may also be taken by the Versico contractor and sent to a third party for moisture and adhesion analysis.
5. When test cuts are to be taken, there is a minimum of 3 cuts required per 10,000 sq. ft. of roof area with additional cut recommended for every additional 10,000 sq. ft. of roofing.
6. Adhesion tests are required and must be coordinated in advance, to determine the extent of surface preparation/cleaning needed to ensure adequate adhesion of the coating and if priming is needed. A minimum three adhesion test area are required per 10,000 sq. ft of roof area with an additional test recommended for every additional 10,000 sq. ft. of roof surface to be restored.

Caution: On Asphaltic roofing, even when achieving acceptable adhesion/peel values, the use of X-Tenda Coat Asphaltic BB Primer is strongly recommended to prevent bleed thru and staining of coating.

Inspection and Assessment

1. This restoration coating system is not suitable for roofs with severe ponding conditions where water accumulates on the surface for periods greater than 48 hours, in areas scattered across of the roof greater than 20%. If restoration is being considered, the affected areas shall be repaired to achieve positive drainage and properly sealed. Refer to appropriate attachment for specific system repairs.
2. Granular surfaces shall be free of any loose granules. Granules that may have become loose due to surface cleaning must be removed. Aggregate (gravel) surfaces are generally not suitable for a coating.
3. Restoration coating of an existing Single-Ply membrane is not recommended if any of the following conditions are observed during inspection:
 - a. The membrane reinforcement scrim is visible or exposed through, in random or multiple locations of significant surface area.
 - b. The membrane is exhibiting brittleness and surface cracking is evident across the surface.
 - c. Attachment method has become unreliable or membrane damage is so excessive that tear off is more appropriate.
 - d. The membrane substrate has been weakened, unattached, or fully saturated.
4. Restoration coating of an existing metal roof system is not recommended, if any of the following conditions are observed during inspection:
 - a. Excessive rusting has compromised the structural integrity of the metal panels. These panels shall be replaced.
 - b. The metal panels have been deformed or fatigued. These panels shall be replaced.
5. Restoration Coating of an existing coating/finish is not recommended if any of the following conditions are observed during inspection:
 - a. The existing coating/finish has well-advanced blistering or flaking.
 - b. Existing roofs with silicone coating can only be coated with silicone coatings. No other coatings are suitable/compatible with the existing silicone.
 - c. Existing roofs with Kynar or other fluoropolymer finishes are not compatible with other coatings and can not be restored with this coating system.
 - d. Existing roofs with reverted Urethane Coatings.
6. Restoration Coating of an existing asphaltic/BUR surface is not recommended if any of the following conditions are observed during inspection:
 - a. The surface has become alligatored, badly weathered or separation between asphaltic plies has occurred

- b. Cap sheets are badly weathered
- c. Uncured asphalt emulsions, roof cements, or mastics are present

These roofs will require various repairs and the removal of any roofing cement before the restoration work. Severely deteriorated roofs or coal tar pitch roofs are not to be restored with this Restoration Coating system.

- 7. An inspection checklist should be prepared and secured for reference along with pictures of key locations where in-depth investigation was suggested.
- 8. For substrate preparation, cleaning and repairs, by the Versico applicator, the appropriate attachment (II thru V) shall be referenced. If necessary, the Versico applicator, may solicit assistance and input from the regional Versico representative.

End of Attachment I



X-TENDA COAT™

COATING SYSTEM

Restoration Coating

Attachment II

Substrate Preparations – Asphaltic Roofing

July 2022

*This attachment is part of the Versico X-Tenda Coat coating restoration system and contains specific information on the various substrate preparations required to restore existing **asphaltic roofs**.*

As a prerequisite, the existing roof surface must be inspected, as outlined in Attachment I, to determine the suitability for restoration and the possible issuance of Versico Warranty. To obtain a warranty, criteria set forth by Versico and outlined in the main specification must be complied with, along with the information contained in this attachment.

A. General

Criteria contained in this Substrate Preparation Attachment is not intended for restoration of existing cold tar pitch roofs. If such projects are encountered Versico must be contacted for recommendations and specific application guidelines.

Note: As outlined in Part I of the Coating Restoration Specification, adhesion tests are required and must be coordinated in advance, preferably, before bidding to determine the need for surface priming, to ensure adequate adhesion of the coating. A minimum three adhesion test areas are required per 10,000 sq. ft area with an additional test area recommended for every additional 10,000 sq. ft. **Even with achieving acceptable adhesion values, the use of X-Tenda Coat Asphaltic BB Primer is strongly recommended to prevent bleed thru and staining of the coating. X-Tenda Coat Bleed Block Base Coat may also be used with X-Tenda Coat Acrylic restoration coatings to prevent bleed thru and staining of the coating.**

1. Substrate preparation contained in this attachment is intended for properly functioning roof systems to prolong and extend their service life.
2. The existing asphaltic roof must be investigated in accordance with the guidelines contained in **Attachment I** of this specification to determine if the existing roof is suitable for restoration.
3. Existing asphaltic roofs with large areas of scattered blistering or those with severe ponding conditions are not suitable for restoration as is. Such roofs must be closely examined to determine the extent of needed repairs prior to restoration, or possible replacement.
4. If moisture entrapment is suspected, and core cuts have been obtained for testing, voids in the substrate must be addressed in these areas.
5. Inspect all surfaces to be coated to ensure they are clean, smooth, sound, properly prepared, and free of moisture, dirt, debris, or other contamination.
6. When X-Tenda Coat **Acrylic** coatings are being considered for restoration, only X-Tenda Coat **Acrylic** mastic can be used. Acrylic coatings are not compatible for application over silicone mastics, sealants or existing silicone coatings.

7. When X-Tenda Coat XTRA **Silicone** coatings are being considered for restoration, the use of X-Tenda Coat XTRA **Silicone** mastic/sealant is recommended.
8. **For additional information the latest edition of “low slope roof manual for repairs” by NRCE may be referenced.**

B. Special Considerations

1. While it is strongly recommended to design roofs with positive drainage to prevent ponding conditions, some incidental ponding may be encountered on existing roofs due to deck deflection or changes in weather patterns.
2. Do not proceed with sealant, mastic or coating application if surface moisture is present, or if the following conditions are anticipated:
 - a. When the dew point is within 5°F of the surface temperature.
 - b. When there is a possibility of rain.
 - c. Temperatures falling below 32°F with in a 24-hour period. Refer to specific PDS for additional guidance.

C. Cleaning

1. All surfaces to be restored must be clean, sound, dry and free of any dirt, grease, oil, debris or other contaminants which would interfere with proper adhesion. Approved cleaning methods include:
 - a. Spudding/Scraping
 - b. Power brooming
 - c. Wet Vacuuming
 - d. Vacuum
 - e. Power washing
2. In low areas where contaminants may have settled, use a brush to ensure the surface is properly cleaned.
3. The substrate must be carefully pressure washed (2,000 psi depending on roof condition) with water. All dirt, dust, chalking, loose materials, etc. must be removed without damaging the surface. Take care not to damage the roof surface or force water into the roof system.
4. Use hot water and a mild detergent to remove grease and/or oils from the roof substrate. If mildew or algae or fungus are present, use a suitable solution to treat these areas, then pressure wash surface.
5. Rinse off the surface when detergent or cleaner is used and wash down drain according to local ordinance.

Note: Loose granules that may have shifted and accumulated should be removed and disposed of, only secured granules should remain.

D. Substrate Repairs

All wet areas must be removed and repaired prior to application of coating. All identified areas that require repairs, follow cleaning procedures out lined in paragh C “Cleaning” to ensure the surface is properly cleaned

prior to application of repair materials.

1. Any areas where BUR or MB has blistered, buckled, and is wet and/or otherwise damaged must be removed and repaired.
2. On built-up roofs with gravel, the entire roof should be spudded to achieve a relatively smooth surface. After cleaning and preparing, apply asphalt emulsion with imbedded Reinforcement fabric as necessary to level off the entire surface.
3. New BUR or MB repair materials must be allowed to weather for at least 30 days and cleaned per Section C prior to application of restoration coating.
4. All areas where BUR or MB substrate surfaces is significantly crazed/cracking (gaps 1/16" or greater in width and/or depth) must be repaired with mastic to bring the substrate to a smooth workable surface.

Note: For other types of built up roofs, apply mastic at all transitions/junctions and around skylights and curbs.

5. Overlay all field seams and transitional details (deck to wall junctions, curbs, skylights, penthouse, etc.) with mastic and coatings. Refer to Versico applicable details for alternative seam overlayment options.
6. Around vent pipes, pitch pockets, drains and other unusual penetration use mastic and coating. The repair shall cover an area 4" in all directions.
7. Areas where core cuts were taken, and no moisture is detected, shall be filled with X-Tenda Coat Mastic and allowed to cure 24 hours. The area should then be capped with coatings, or a layer of Reinforcement Fabric imbedded in two layers of coating.
8. At raised expansion joints, if necessary, seal perpendicular joints of the expansion joint cover using at least 2 layers of Reinforcement Fabric (minimum of 4" and 8" respectively) imbedded in multiple layers of coating.
9. All blisters shall be cut, dried out, re-adhered and sealed with appropriate roof mastic. Large blister (12" or greater), after allowing mastic to dry, may require an application of X-Tenda Coat Reinforcement Fabric encapsulated in a base coat and a topcoat.
10. At all other locations where surface cracks or splits are evident repair using mastic or with Reinforcement Fabric imbedded in coating.

E. Final preparation before coating

Re-examine the roof to ensure the surface is clean and dry as described in Article C "Cleaning". If necessary, repeat the cleaning procedures and allow the surface to dry before coating.

1. Ensure all roof penetrations, curbs, skylights, cants, edge metal and other roof mounted equipment are in place and secure.
2. Coordinate work with building maintenance personnel to ensure that air intake units are temporarily sealed to prevent coating overspray and fumes from entering occupied spaces.
3. Confirm that all adjacent surfaces surrounding the work area are adequately protected from overspray and frequent construction traffic.
4. Apply primer if required.

F. Coating Application and Cleanup Work

Refer to part III of the Coating Restoration Specification.

End of Attachment II



X-TENDA COAT™

COATING SYSTEM

Restoration Coating

Attachment III

Substrate Preparations – Metal Roofing

July 2022

*This attachment is part of the Versico X-Tenda Coat coating restoration system and contains specific information on the various substrate preparations required to restore existing **metal roofs**.*

As a prerequisite, the existing roof surface must be inspected, as outlined in Attachment I, to determine their suitability for restoration and the possible issuance of Versico Warranty. To obtain a warranty, criteria set forth by Versico and outlined in the main specification must be complied with, along with the information contained in this attachment.

A. General

As outlined in Part I of the Coating Restoration Specification, adhesion tests are required and must be coordinated in advance, preferably, before bidding to determine the need for surface priming, to ensure adequate adhesion of the coating. A minimum three adhesion test areas are required per 10,000 sq. ft area with an additional test recommended for every additional 10,000 sq. ft. Even with achieving acceptable adhesion values, the use of X-Tenda Coat Metal Primer is strongly recommended to resist further rust.

1. Substrate preparation contained in this attachment is intended for properly functioning roof systems in order to prolong and extend its surface life.
2. The existing metal roof must be investigated in accordance with the guidelines contained in **Attachment I** of this specification to determine if the existing roof is suitable for restoration.
3. Existing metal roofs with large areas of heavy rust (greater than 20% of roof surface) or rusted through panels are generally not candidates for successful restoration. Such roofs must be closely examined to determine the extent of needed repairs and possible panel replacement.
4. When the X-Tenda Coat **Acrylic** coating is being considered for restoration, only Versico X-Tenda Coat **Acrylic** mastic can be used. Acrylic coatings are not compatible for application over silicone mastics, sealants or existing silicone coatings.
5. When the X-Tenda Coat XTRA **Silicone** coating is being considered for restoration, the use of X-Tenda Coat XTRA **Silicone** mastic/sealant is recommended.
6. Inspect surfaces which will receive the X-Tenda Coat XTRA Silicone & X-Tenda Coat Acrylic coating to make sure they are clean, smooth, sound, properly prepared, and free of moisture, dirt, debris, or other contamination.

B. Special Considerations

1. Do not proceed with sealant, mastic or coating application if surface moisture is present, or if the following conditions are anticipated:

- a. When the dew point is within 5°F of the surface temperature.
 - b. When there is a possibility of rain.
 - c. Temperatures falling below 32°F with in a 24-hour period. Refer to specific PDS for additional guidance.
2. Remove excessive amounts of asphaltic-based soft mastic, other deteriorated patching or flashing materials if present.
 3. If the existing roof has been coated with Aluminized asphalt, contact Versico for an appropriate primer.

C. Cleaning

1. All surfaces to be restored must be clean, sound, dry and free of any dirt, grease, oil, debris or other contaminants which would interfere with proper adhesion. Approved cleaning methods include:
 - a. Brooming
 - b. Power washing
 - c. Scrapping
 - d. Sand blasting
2. In low areas where contaminants may have settled, use a soft bristled brush to ensure the surface is properly cleaned. Loose coating should be removed prior to application of coating.

D. Substrate Repairs

1. **Medium** or **heavily** rusted areas shall be wire brushed, sandblasted or mechanically abraded to remove all loose rust. Metal panels deteriorated to the point that their structural integrity is compromised shall be replaced.
2. All **lightly** rusted areas, where rust was mechanically removed, shall be primed with X-Tenda Coat Metal Primer.
3. Check all seams to ensure that they are tight and flush. Excessive gaps or deflection between panels shall be eliminated by installing additional fasteners or rivets as necessary to limit deflection to 1/4" (6mm) or less.
4. All metal surfaces shall be cleaned with minimum 2,000 psi water to remove any existing loose paint or coating. Heavy deposits of dirt or contamination may require agitation with a stiff bristle broom. Allow the roof to dry thoroughly.
5. Fill gaps between 1/4" and 1/2" (6-13mm) at panel seams, joints and protrusions with Versico approved sealant or tape. Fill gaps larger than 1/2" (13mm) at the ridge cap, roof edge and/or interface of dissimilar materials with a polyethylene backer rod.
6. All mechanical fasteners shall be checked for integrity. Retighten or replace as necessary. "Stripped out" fasteners shall be replaced using a larger diameter fastener. All fasteners must be fully encapsulated with appropriate Versico mastic.
7. Overlay all field seams and transitional details (deck to wall junctions, curbs, skylights, penthouse, etc.) by three coursing. Refer to Versico applicable details for alterative seam overlayment options.

8. Around vent pipes, pitch pockets, and other unusual penetrations, use mastic and coating. The repair shall cover an area 4" in all directions.
9. Caulk or fill all cracks, holes or other surface imperfections with appropriate Versico sealant/mastic. All sealant/mastic must be thoroughly dry before application of coating.
10. Any new metal must be clean and oil-free. Prime ferrous metal with X-Tenda Coat Metal Primer at the rate of 1 gallon per 100-200 square feet. For non-ferrous metals, contact Versico.

E. Final preparation before coating

Re-examine the roof to make sure the surface is clean and dry as described in Article C "Cleaning".

1. Ensure all roof penetrations, curbs, skylights, cants, edge metal and other roof mounted equipment are in place and secure.
2. Coordinate work with building maintenance personnel to ensure that air intake units are temporarily sealed to prevent coating overspray and fumes from entering occupied spaces.
3. Confirm that all adjacent surfaces surrounding the work area are adequately protected from overspray.

F. Coating Application and Cleanup Work

Refer to part III of the Coating Restoration Specification.

End of Attachment III



X-TENDA COAT™

COATING SYSTEM

Restoration Coating

Attachment IV

Substrate Preparations – EPDM, TPO and PVC

July 2022

*This attachment is part of the Versico X-Tenda Coat coating restoration system and contains specific information on the various substrate preparations required to restore existing **Single Ply roofs**.*

As a prerequisite, the existing roof surface must be inspected, as outlined in Attachment I, to determine their suitability for restoration and the possible issuance of Versico Warranty. To obtain a Restoration System Warranty or Restoration Material warranty, criteria set forth by Versico and outlined in the main specification must be complied with, along with the information contained in this attachment.

A. General

Substrate preparation contained in this attachment is intended for properly functioning roof systems to prolong and extend their service life.

The existing single-ply roof must be investigated in accordance with the guidelines contained in **Attachment I** of this specification to determine if the existing roof is suitable for restoration.

1. Adhesion tests are required and must be coordinated in advance, to determine if additional surface preparation/cleaning may be needed, and to ensure adequate adhesion of the coating. A minimum of three adhesion test areas are required per 10,000 sq. ft area with an additional test area recommended for every additional 10,000 sq. ft.
 - a. Aged or new EPDM must be cleaned and power washed.
 - b. Aged TPO must be cleaned, power washed and then primed with X-Tenda Coat TPO primer.
 - c. New TPO must be primed with X-Tenda Coat TPO primer.
 - d. Aged PVC/KEE membrane must be cleaned, power washed and then primed with X-Tenda Coat Asphaltic BB primer. Primer is only required when using X-Tenda Coat Acrylic coatings.

Note: Contact Versico for additional cleaning and primer recommendations

2. Existing single ply roofs with large areas of delamination, those with severe ponding conditions or those with large areas of wind damage are not candidates for restoration. Such roofs must be closely examined to determine the extent of needed repairs, or possible replacement.
3. Projects where the membrane has crazed and cracked in areas greater than 20% of the roof should be assessed and membrane replaced as necessary.

4. When the X-Tenda Coat **Acrylic** coating is being considered for restoration, only X-Tenda Coat **Acrylic**

mastic can be used for repairs. Acrylic coatings are not compatible for application over silicone mastics, sealants or existing silicone coatings.

5. When X-Tenda Coat XTRA **Silicone** coating is being considered for restoration, the use of **Silicone** mastic/sealant is recommended.
6. Inspect surfaces which will receive the X-Tenda Coat XTRA Silicone or X-Tenda Coat Acrylic coating to make sure they are clean, smooth, sound, properly prepared, and free of moisture, dirt, debris, or other contamination.

B. Special Considerations

1. While it is strongly recommended to design roofs with positive drainage to prevent ponding conditions, some incidental ponding may be encountered on existing roofs due to deck deflection or inadequate roof drainage. If ponding remains after 48 hours tapered insulation should be used to achieve positive drainage, refer to Part D "Substrate Repairs".
2. Do not proceed with sealant, mastic or coating application if surface moisture is present, or if the following conditions are anticipated:
 - a. When the dew point is within 5°F of the surface temperature.
 - b. When there is a possibility of rain.
 - c. Temperatures falling below 32°F with in a 24-hour period. Refer to specific PDS for additional guidance.

C. Cleaning

1. All surfaces to be restored must be clean, sound, dry and free of any dirt, grease, oil, debris or other contaminants which would interfere with proper adhesion. Approved cleaning methods include:
 - a. General Cleaners
 - b. Brooming
 - c. Power washing – a minimum working pressure of 2,000 psi is to be used.
2. Aged or new EPDM must be cleaned and power washed.
3. Aged TPO must be cleaned, power washed, and then primed with X-Tenda Coat TPO primer.
4. New TPO must be primed with X-Tenda Coat TPO primer.
5. Aged PVC/KEE membrane must be cleaned, power washed, and then primed with X-Tenda Coat Asphaltic BB primer. Primer is only needed when using X-Tenda Coat Acrylic coatings.

Note: For cleaning/priming new PVC membrane, Versico must be contacted for applicable requirements.

6. In low areas where contaminants may have settled, use a stiff bristled brush to ensure the surface is properly cleaned.
7. Care should be taken not to damage the roof surface or inject water into the substrate during washing.
8. Allow at least 48 hours for complete drying after the cleaning process.

D. Substrate Repairs

Prior to substrate preparation and repairs to receive the restoration coating, ensure that areas with extensive repairs (removal and replacement of wet areas, overlayment of open seams, replacement of delaminated areas, deteriorated flashing, etc.), are completed and the roof has been restored to a watertight condition.

1. At field seams that have not been repaired for the purpose of this restoration work:
 - a. Cut and remove fish mouths and loose membrane. Areas shall be filled with mastic and allowed to cure.
 - b. Partially delaminated seams with delamination of 1" or less will require the removal of loose membrane and the use of mastic/sealant to fill the void.
 - c. Overlay the seams with 4-6" wide section, centered over the seam, of Reinforcement Fabric imbedded in the base coat and encapsulated in the topcoat. Refer to Versico spec and details for additional options.
2. At penetrations, field fabricated pipes, scuppers, sealant pockets, and inside and outside corners, where uncured flashing may have been used:
 - a. Encapsulate uncured flashing with mastic, extending the application onto the deck membrane approximately 2-4".
 - b. As an alternative use Reinforcement Fabric imbedded in the base coat and covered with the topcoat. The fabric must also extend horizontally 2-4" on the deck membrane.
3. Small punctures and small tears (3" or less) shall be repaired using one of the following:
 - a. After priming/reactivating with a compatible pressure sensitive overlay extending 2" in all directions. For EPDM and TPO membranes, EPDM overlay may be used. For PVC and KEE membranes PVC pressure sensitive cover strip may be used.
 - b. Use X-Tenda Coat Mastic/Sealant to cover puncture areas and Reinforcement Fabric embedded in a base coat and covered with a top coat to seal the membrane. The repair area must extend a minimum of 2" in all directions.
 - c. Use mastic to cover punctures or tears, extending 2" beyond the damaged area.
4. At metal edging where, flashing overlay has been used, overlay the junction of the flashing on the deck side with Reinforcement Fabric (similar to field seams) centered over the splice edge and imbedded in the base coat. Use X-Tenda Coat Mastic/Sealant along the edge of the overlay facing the meal edge to totally encapsulate the edge of the overlay. When applicable, prime the metal with the appropriate primer before applying the mastic. The entire overlay and Reinforcement Fabric must be covered with a final topcoat.
5. At sealant pockets, after cleaning the penetration, apply generous amount of X-Tenda Coat Mastic/Sealant to encapsulate existing sealant extending the mastic up the penetration approximately 1-2"
6. All expansion joints located at deck level where the membrane is used as an expansion joint cover must be overlaid with 2 layers of Reinforcement Fabric imbedded into 2 applications of base coat and covered with one topcoat. The first layer of Reinforcement Fabric must extend 4" beyond the single ply flashing and the second layer must also extend 4" beyond the first layer.
7. Flashing details must be examined for loose or deteriorated flashing, cuts, tears and open inside or outside corners. Membrane and flashing terminations should be examined at perimeters, roof penetrations and

drains to ensure watertight performance. Deficient terminations should be corrected in accordance with the appropriate Versico published detail.

8. Minor crazing, cracking, tears or punctures may be repaired using applicable single ply technology for the specific membrane type.

Note: On TPO projects, repairs can be accomplished using either pressure sensitive EPDM or TPO where possible.

E. Final preparation before coating

Re-examine the roof to ensure the surface is clean and dry as described in Article C “Cleaning”. If necessary, repeat the cleaning procedures and allow the surface to dry before coating.

1. Ensure all roof penetrations, curbs, skylights, edge metal and other roof mounted equipment are in place and secure.
2. Coordinate work with building maintenance personnel to ensure that air intake units are temporarily sealed to prevent coating overspray and fumes from entering occupied spaces.
3. Confirm that all adjacent surfaces surrounding the work area are adequately protected from overspray and frequent construction traffic.
4. Apply primer if required.

F. Coating Application and Cleanup Work

Refer to part III of the Coating Restoration Specification.

End of Attachment IV



X-TENDA COAT™

COATING SYSTEM

Restoration Coating Details

Table of Contents

July 2022

Substrates	Page
Roof Types & Coating Application.....	XC-0
Metal Edges	
Metal Edge – EPDM/TPO/PVC Roof: (Applicable to Gutter Edge Also).....	XC-1A
Metal Edge – Bituminous Roof: (Applicable to Gutter Edge Also).....	XC-1B
Field Seams	
Field Seam Treatment (Method A &B).....	XC-2
Pipe Flashing	
Treatment of Pre-Molded Pipe/Tubing Flashing	XC-8A
Treatment of Field Fabricated Pipe/Tubing Flashing	XC-8B
Method B: Step-by-Step Flashing with Reinforcement Fabric & Coating.....	XC-8C
Repairs	
Repair: Split Flashing at Metal Joint – Bituminous Roofs.....	XCR-1
Repair: Seam Gap or Wrinkle.....	XCR-2A
Repair: Seam Partially Delaminated.....	XCR-2B
Repair: Seam Repair at Deficient Base Flashing.....	XCR-2C
Repair – Method A (Mastic): Blister/ Wrinkles.....	XCR-2D
Repair – Method B: (Reinforcement Fabric) Blisters/Wrinkles.....	XCR-2E
Repair: Wrinkles at Roof-To-Wall Junction.....	XCR-12
Metal Roofs	
Standing Seam Metal Roof Coating.....	XCM-2A
Metal Roof: Seam Treatment of Various Profiles.....	XCM-2B
Treatment of Exposed Fasteners.....	XCM-2C
Panels End Lap & Side Lap Details.....	XCM-2D

ROOF RESTORATION WITH ELASTOMERIC COATING

OPTIONAL COATING WITH GRANULES.
(REFER TO SPECS)



(A) EXISTING EPDM
ROOF MEMBRANE

OPTIONAL COATING WITH GRANULES.
(REFER TO SPECS)

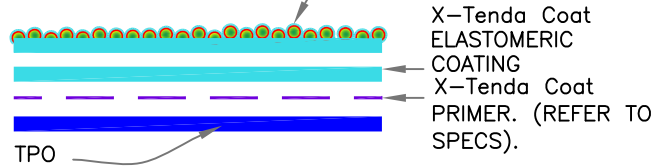

(B) EXISTING TPO
ROOF MEMBRANE

OPTIONAL COATING WITH GRANULES.
(REFER TO SPECS)

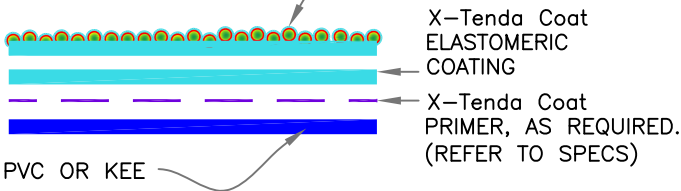

(C) EXISTING PVC / KEE
ROOF MEMBRANE

OPTIONAL COATING WITH GRANULES.
(REFER TO SPECS)

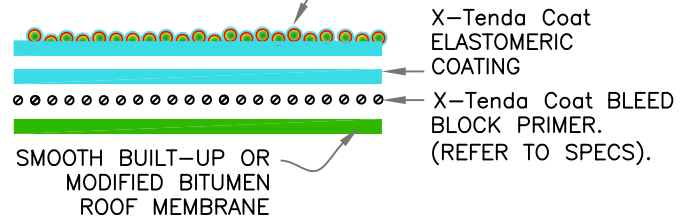

(D) EXISTING SMOOTH
BUR / MOD BIT



- X-Tenda Coat COATING
- X-Tenda Coat PRIMER
- REINFORCEMENT
- X-Tenda Coat MASTIC
- 0 NOTE(S)

ROOF TYPES & COATING APPLICATION

NEW COATING ON EXISTING LOW SLOPE ROOFS

For additional information, refer to Specifications

X-Tenda Coat

XC-0

ROOF RESTORATION WITH ELASTOMERIC COATING

GUIDE
NOTE

WHERE GUTTER EXISTS, TO MAINTAIN POSITIVE DRAINAGE, USE METAL DRIP EDGE WITHOUT DAM.

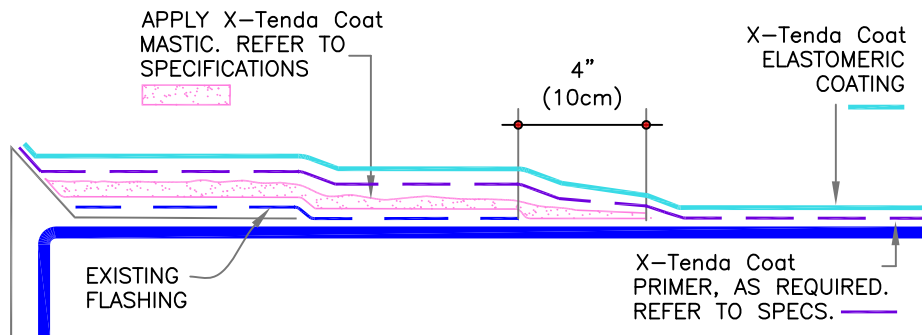
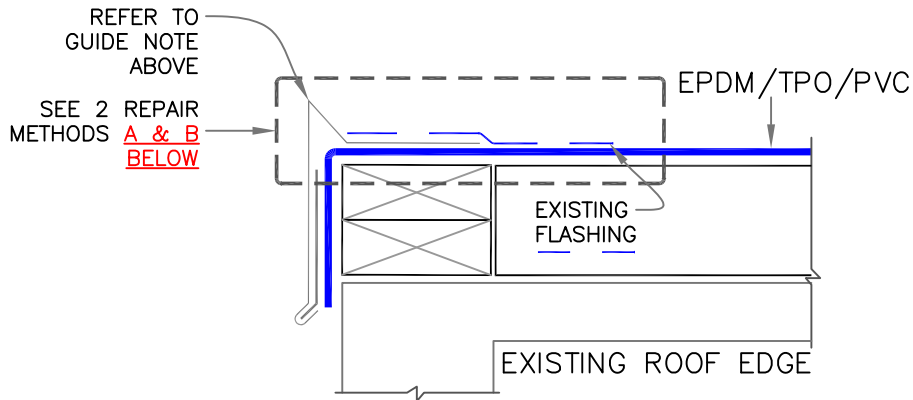

METHOD A: MASTIC APPLICATION

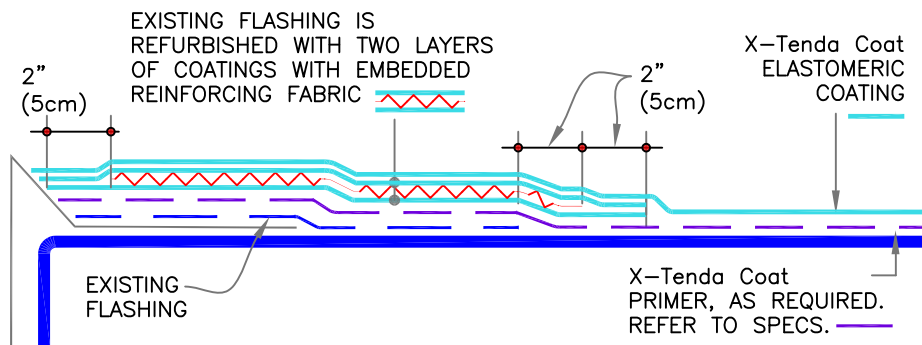

METHOD B: COATING WITH FABRIC

<p>VERSICO ROOFING SYSTEMS</p> <p>— X-Tenda Coat COATING</p> <p>— X-Tenda Coat PRIMER</p> <p>— REINFORCEMENT</p> <p>— X-Tenda Coat MASTIC</p> <p>0 NOTE(S)</p>	METAL EDGE – EPDM/TPO/PVC ROOF: (APPLICABLE TO GUTTER EDGE ALSO)	X-Tenda Coat
	NEW COATING ON EXISTING LOW SLOPE ROOFS	XC-1A
	For additional information, refer to Specifications	

ROOF RESTORATION WITH ELASTOMERIC COATING

GUIDE
NOTE

WHERE GUTTER EXISTS, TO MAINTAIN POSITIVE DRAINAGE, USE METAL DRIP EDGE WITHOUT DAM.

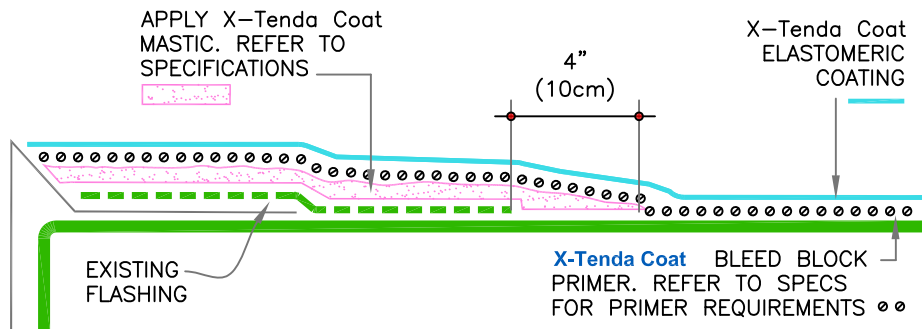
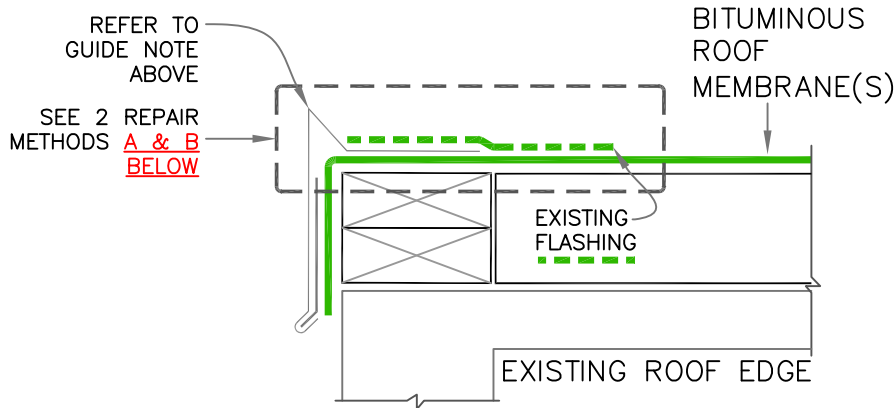

METHOD A: MASTIC APPLICATION

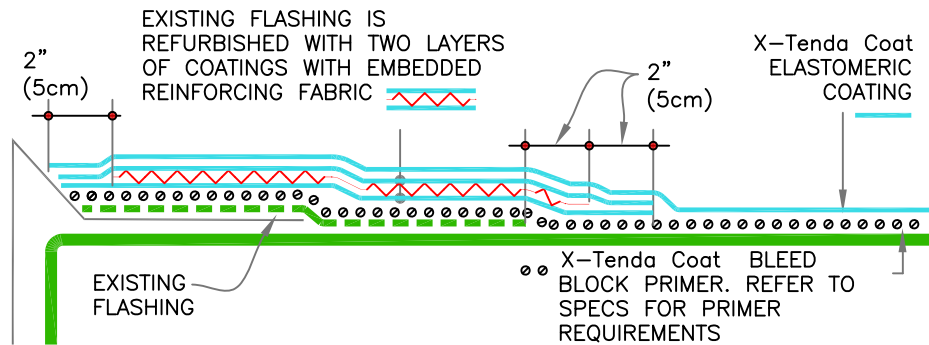

METHOD B: COATING WITH FABRIC

<p>VERSICO ROOFING SYSTEMS</p> <p>X-Tenda Coat COATING</p> <p>X-Tenda Coat PRIMER</p> <p>REINFORCEMENT</p> <p>X-Tenda Coat MASTIC</p> <p>NOTE(S)</p>	METAL EDGE – BITUMINOUS ROOF: (APPLICABLE TO GUTTER EDGE ALSO)	X-Tenda Coat
	NEW COATING ON EXISTING LOW SLOPE ROOFS	XC-1B
	For additional information, refer to Specifications	

TREATMENT METHOD A

NOTES:

1. THIS REPAIR LEVEL TO BE USED ON SEAMS WITH ACCEPTABLE CONDITIONS. FOR MORE DETERIORATED SEAMS, SEE REPAIR LEVEL 2 BELOW. THIS WILL APPLY TO ALL THE SIDE AND END LAPS.
2. THOROUGHLY CLEAN THE REPAIR AREA.
3. APPLY X-Tenda Coat PRIMER AS REQUIRED. REFER TO SPECS.
4. APPLY X-Tenda Coat MASTIC, EXTENDING MIN. 4" (10cm) ON EACH SIDE OF SEAM.

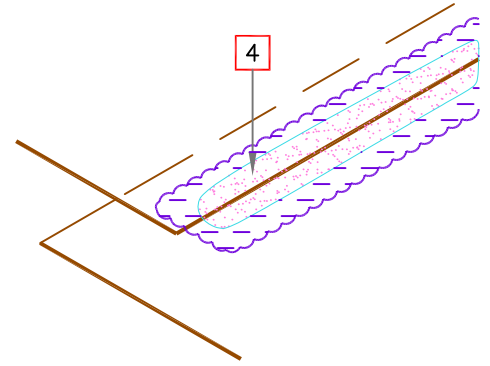
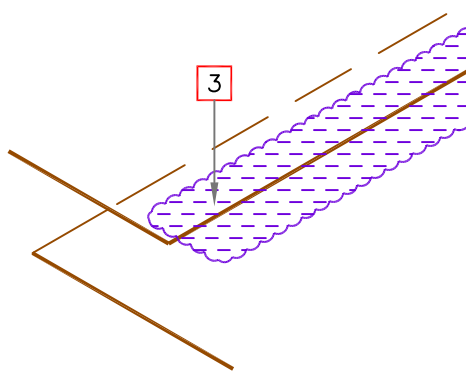

TREATMENT METHOD B

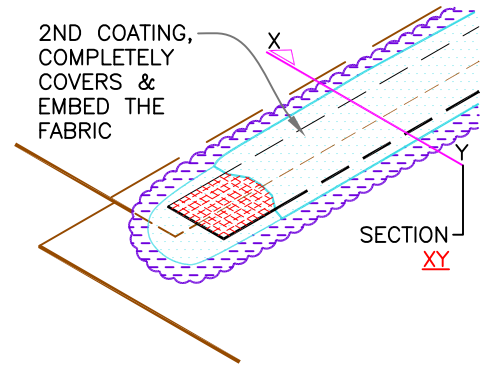
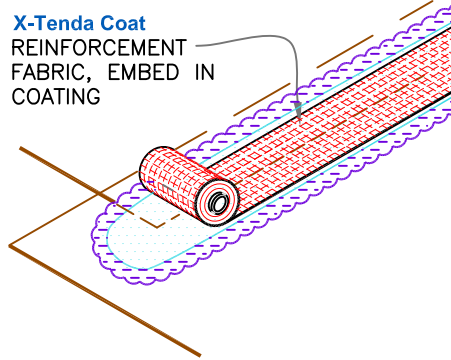
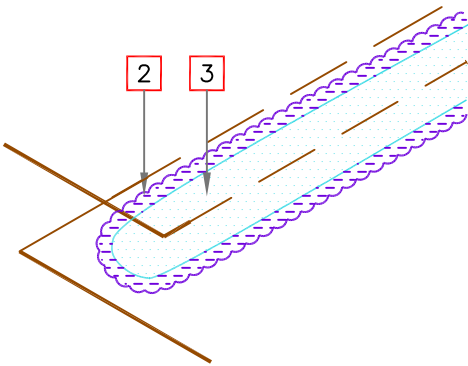

STEP 1:

1. THOROUGHLY CLEAN THE REPAIR AREA.
2. APPLY X-Tenda Coat PRIMER AS REQUIRED. REFER TO SPECS.
3. APPLY LAYER OF COATING 2" (5cm) MIN. BEYOND THE WIDTH OF REINFORCING FABRIC.

STEP 2:

1. IMMEDIATELY, LAY THE X-Tenda Coat REINFORCEMENT FABRIC, CENTRALLY ALIGNED AT SEAM EDGE.
2. COMPLETELY SOAK AND EMBED THE FABRIC IN COATING.

STEP 3:

1. IMMEDIATELY, APPLY A 2ND LAYER OF COATING COMPLETELY COVERING THE REINFORCEMENT FABRIC.

SECTION XY

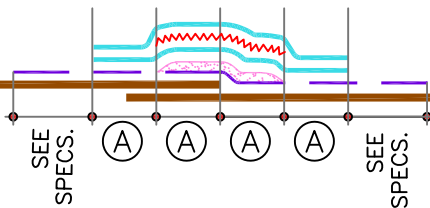

DIMENSIONS	cm	
(A)	2"	5 MIN.

<p>VERSICO ROOFING SYSTEMS</p> <p>— X-Tenda Coat COATING — X-Tenda Coat PRIMER — REINFORCEMENT</p> <p>— X-Tenda Coat MASTIC</p> <p>0 NOTE(S)</p>	FIELD SEAM TREATMENT (METHOD A & B)	X-Tenda Coat
	NEW COATING ON EXISTING LOW SLOPE ROOFS	XC-2
	For additional information, refer to Specifications	

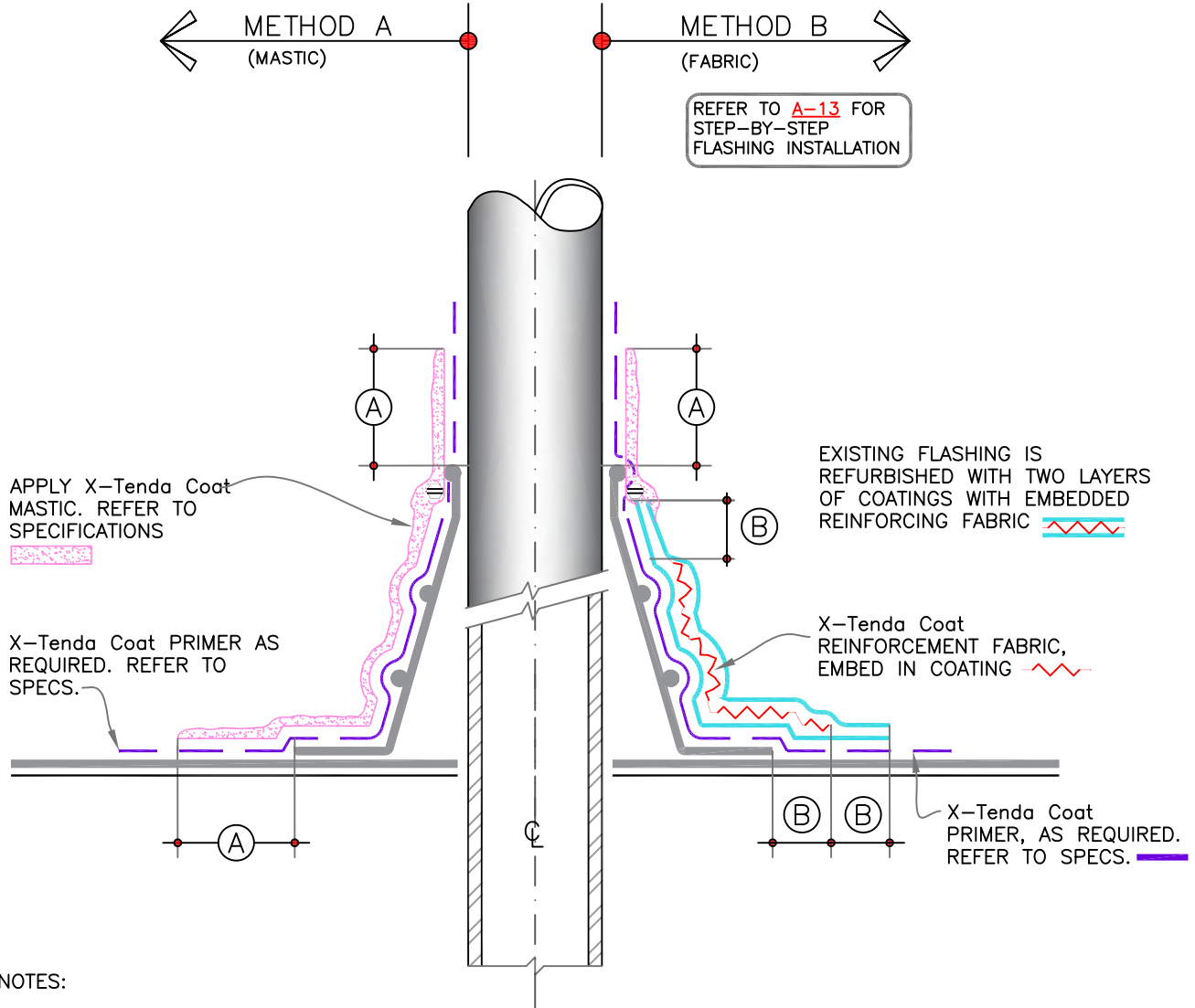

DIMENSIONS		cm	
(A)	4"	10	MIN.
(B)	2"	5	MIN.

<p>VERSICO ROOFING SYSTEMS</p> <p>X-Tenda Coat COATING</p> <p>X-Tenda Coat PRIMER</p> <p>REINFORCEMENT</p> <p>X-Tenda Coat MASTIC</p> <p>NOTE(S)</p>	<p>TREATMENT OF PRE-MOLDED PIPE/TUBING FLASHING</p>	X-Tenda Coat
	<p>NEW COATING ON EXISTING LOW SLOPE ROOFS</p> <p>For additional information, refer to Specifications</p>	XC-8A

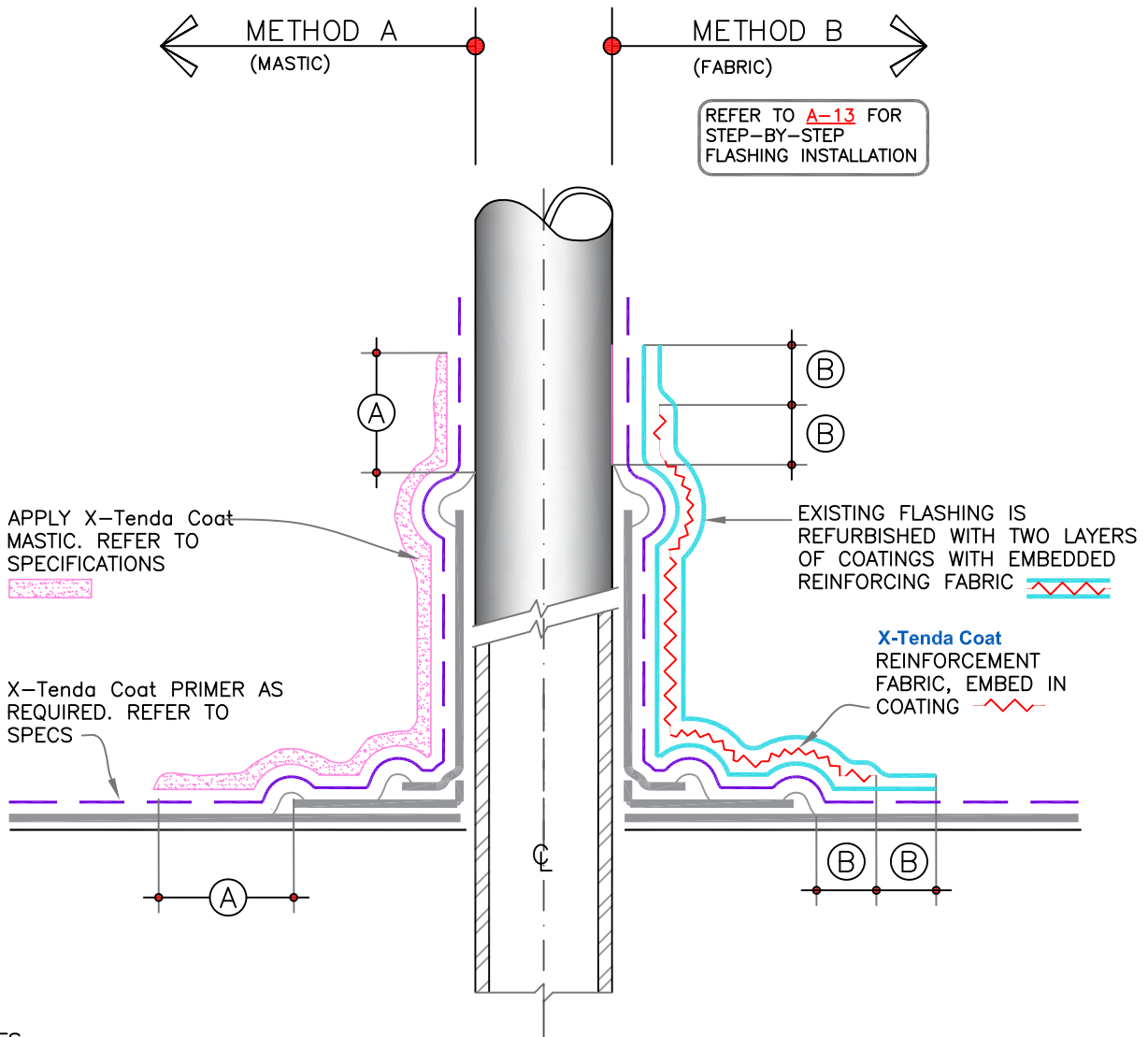

DIMENSIONS		cm	
(A)	4"	10	MIN.
(B)	2"	5	MIN.

<p>VERSICO ROOFING SYSTEMS</p> <p>X-Tenda Coat COATING</p> <p>X-Tenda Coat PRIMER</p> <p>REINFORCEMENT</p> <p>X-Tenda Coat MASTIC</p> <p>NOTE(S)</p>	<p>TREATMENT OF FIELD FABRICATED PIPE/TUBING FLASHING</p> <p>NEW COATING ON EXISTING LOW SLOPE ROOFS</p> <p>For additional information, refer to Specifications</p>	<p>X-Tenda Coat</p> <p>XC-8B</p>
	<p>© 2024 Versico</p>	

ROOF RESTORATION WITH ELASTOMERIC COATING

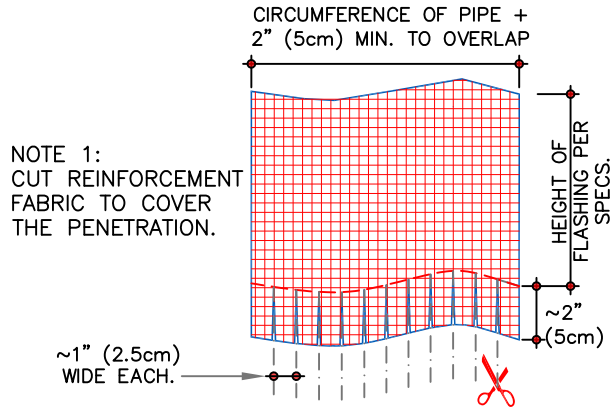

A

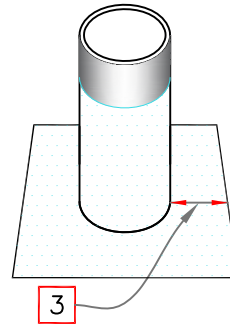

1. ENSURE COATING RECEIVING AREAS ARE CLEAN, SMOOTH AND DRY.
2. PRIME SURFACES AS REQUIRED. REFER TO SPECS.
3. APPLY BOTTOM COATING MIN. 2" (5cm) BEYOND THE DIMENSIONS OF PRE-CUT REINFORCEMENT FABRIC.

B

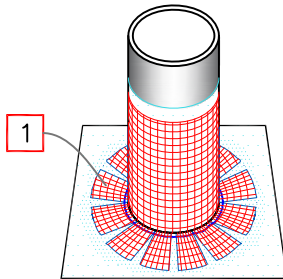

1. LAY THE PRE-CUT REINFORCEMENT FABRIC SHOWN IN (A) INTO BOTTOM LAYER OF COATING.

C

REFER TO [A-11](#) OR [A-12](#) FOR MIN. DIMENSIONS

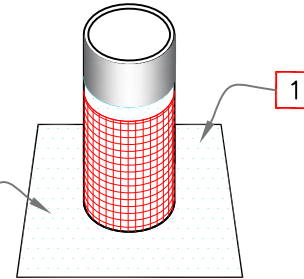

1. APPLY COATING ON HORIZONTAL PORTION (ROOF SURFACE), COVERING THE FINGER CUTS AND THE REMAINING RECEIVING AREA OF HORIZONTAL REINFORCEMENT.

D

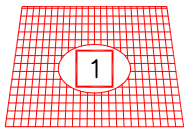

ONE-PIECE FABRIC

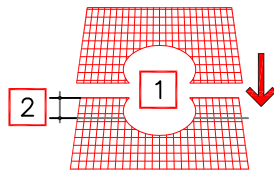

TWO-PIECE FABRIC

1. CUT REINFORCEMENT FABRIC TO FIT TO PENETRATION TYPE AND DIMENSIONS. TWO-PIECE IS USED, WHERE ONE PIECE CANNOT BE INSERTED OVER THE PENETRATION.
2. TOP PIECE OVERLAPS 2" (5cm) ON BOTTOM PIECE.

E

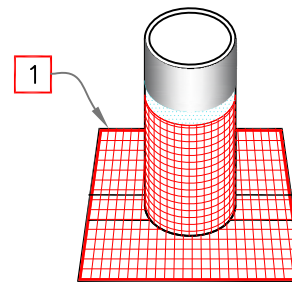

1. LAY THE PRE-CUT REINFORCEMENT FABRIC SHOWN IN "E" IN HORIZONTAL LAYER OF COATING.

F

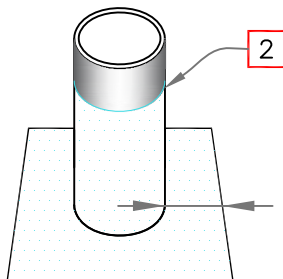

REFER TO [A-11](#) OR [A-12](#) FOR MIN. DIMENSIONS

NOTES:

1. APPLY THE TOP COATING ON BOTH HORIZONTAL AND VERTICAL SURFACES AS DEPICTED.
2. FOR MOLDED PIPE FLASHING, APPLY SEALANT/MASTIC ABOVE CLAMPING RING, REFER TO [A-11](#).

G

<p>VERSICO ROOFING SYSTEMS</p> <p>X-Tenda Coat COATING X-Tenda Coat PRIMER REINFORCEMENT</p> <p>X-Tenda Coat MASTIC</p> <p>NOTE(S)</p>	METHOD B: STEP-BY-STEP FLASHING WITH REINFORCEMENT FABRIC & COATING	X-Tenda Coat
	NEW COATING ON EXISTING LOW SLOPE ROOFS	XC-8C
	For additional information, refer to Specifications	

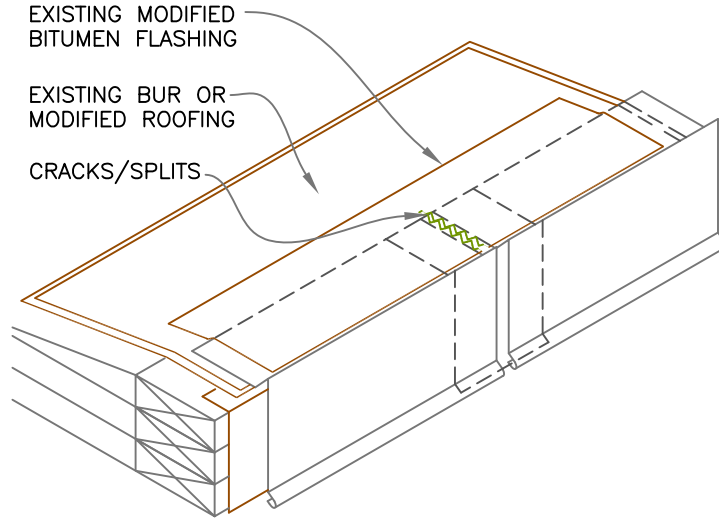

EXISTING CONDITION

A

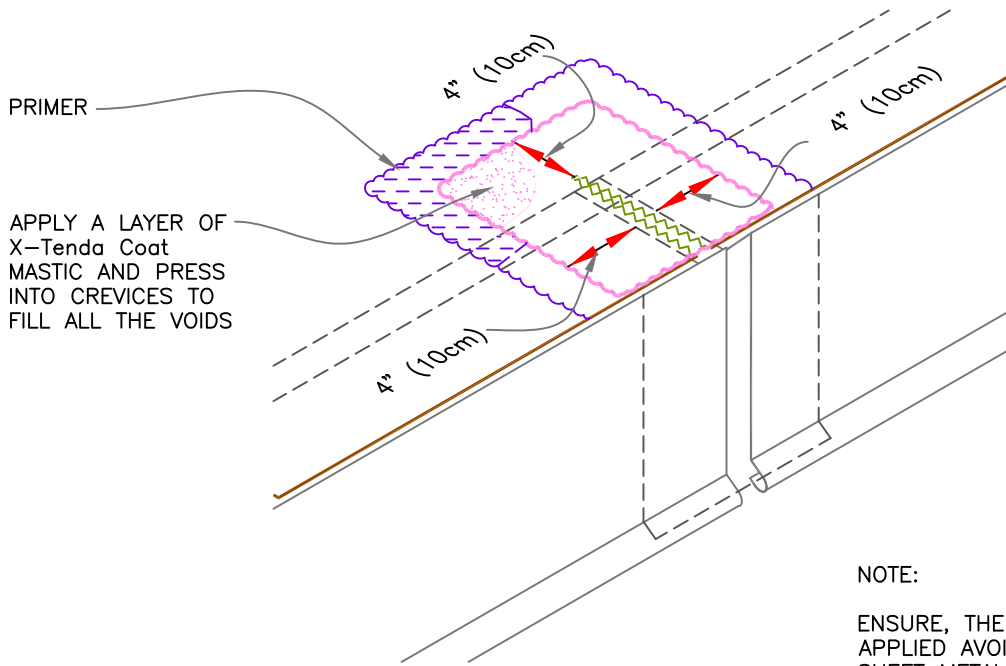

REPAIR DETAIL

NOTE:

ENSURE, THE MASTIC IS CAREFULLY APPLIED AVOIDING THE SMEARING ON THE SHEET METAL FASCIA.

B

<p>VERSICO ROOFING SYSTEMS</p>	<p>REPAIR: SPLIT FLASHING AT METAL JOINT – BITUMINOUS ROOFS</p>	X-Tenda Coat
	<p>NEW COATING ON EXISTING LOW SLOPE ROOFS</p> <p>For additional information, refer to Specifications</p>	XCR-1

ROOF RESTORATION WITH ELASTOMERIC COATING

DEFICIENCY:
SIDE SEAM, OPEN,
WRINKLED OR FISH
MOUTH CONDITION.

NOTE:
REPAIR BOTH DEFICIENCIES
PER STEPS **B TO G**.

A

LIFT UP AND
CUT THE SEAM
AT THE PEAK
OF FISHMOUTH
OR LOOSE SEAM

TRIM CORNERS TO
ELIMINATE
CURLING UP OF
MEMBRANE.

FOLD BACK
EDGES. REMOVE
MOISTURE, DIRT
& THOROUGHLY
CLEAN WITHIN
OPENED AREA.

B

C

X-Tenda Coat PRIMER
AS REQUIRED. REFER
TO SPECS.

APPLY MASTIC & RESET
THE MEMBRANE BACK
ENSURING NO VOIDS.

D

E

X-Tenda Coat
PRIMER AS
REQUIRED. REFER TO
SPECS.

APPLY TOP LAYER OF MASTIC. EXTEND MIN. 4"
(10cm) BEYOND REPAIR AREA



F

G



REPAIR:
SEAM GAP OR WRINKLE

X-Tenda Coat

-  X-Tenda Coat COATING
-  X-Tenda Coat PRIMER
-  REINFORCEMENT

 X-Tenda Coat MASTIC

 NOTE(S)

NEW COATING ON EXISTING LOW SLOPE ROOFS

For additional information, refer to Specifications

XCR-2A

DEFICIENCY:
PARTIALLY
DELAMINATED SEAM.

DEFICIENT SEAM – 3D VIEW

A

USE MASTIC TO SET THE
MEMBRANE AND PRESS
DOWN

X-Tenda Coat PRIMER
AS REQUIRED. REFER
TO SPECS.

X-Tenda Coat PRIMER
AS REQUIRED. REFER
TO SPECS.

MASTIC

4" min.
(10cm) 4" min.
(10cm)

REPAIR STEP 1

REPAIR STEP 2





B

C



REPAIR:
SEAM PARTIALLY DELAMINATED

X-Tenda Coat

-  X-Tenda Coat COATING
-  X-Tenda Coat PRIMER
-  REINFORCEMENT
-  X-Tenda Coat MASTIC
-  NOTE(S)

NEW COATING ON EXISTING LOW SLOPE ROOFS

XCR-2B

For additional information, refer to Specifications

ROOF RESTORATION WITH ELASTOMERIC COATING

NOTE: SAME DETAIL APPLIES FOR FISH MOUTHS IN THE FIELD OF ROOF.

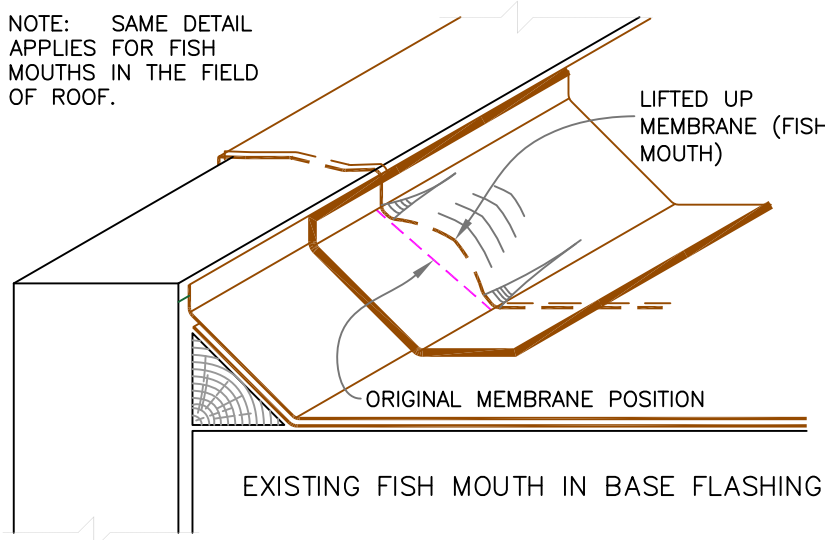

AT EXISTING FISH MOUTH CUT PERPENDICULAR TO FISH MOUTH UP TO LOOSE CONDITION.

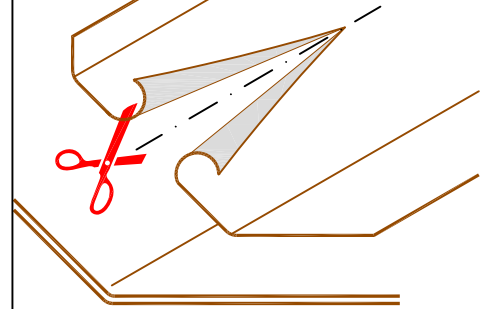

A

B

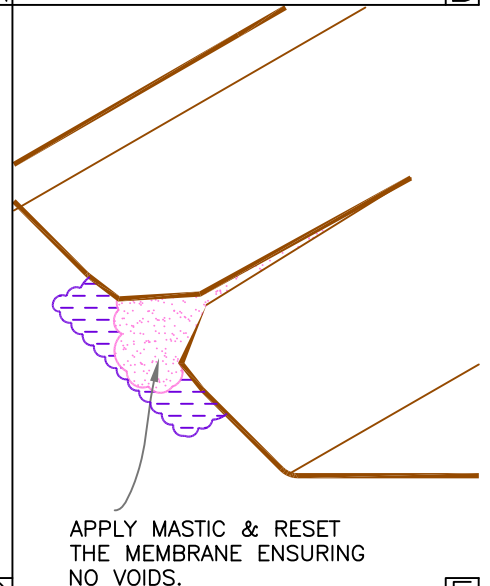
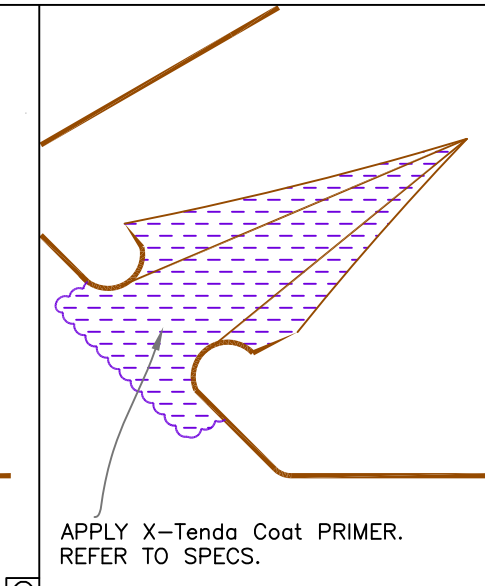
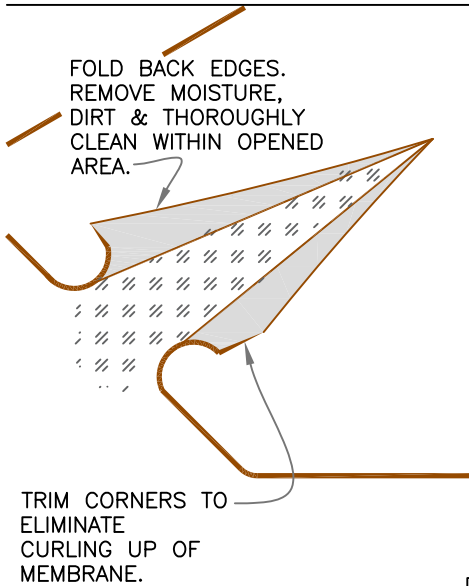

C

D

E

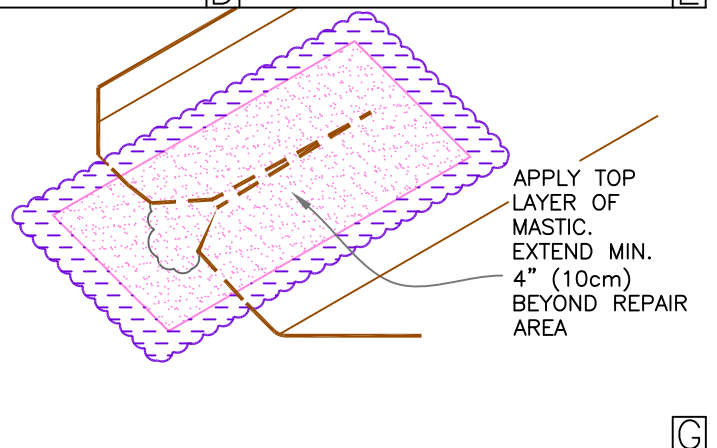
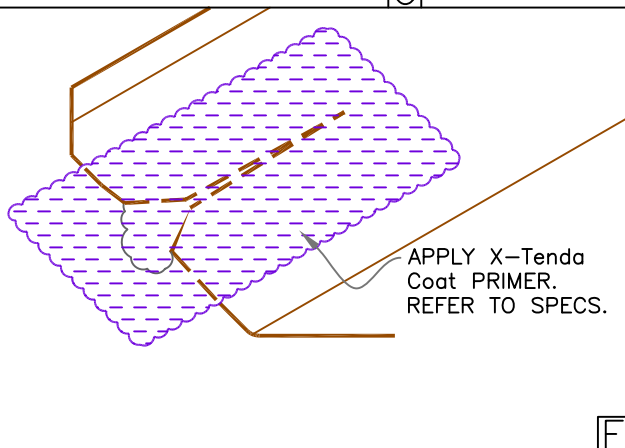

F

G

<p>VERSICO ROOFING SYSTEMS</p>	REPAIR: SEAM REPAIR AT DEFICIENT BASE FLASHING	X-Tenda Coat
	NEW COATING ON EXISTING LOW SLOPE ROOFS	XCR-2C
<p>— X-Tenda Coat COATING</p> <p>— X-Tenda Coat PRIMER</p> <p>~ REINFORCEMENT</p> <p>○ NOTE(S)</p>	For additional information, refer to Specifications	

EXISTING WRINKLED BASE FLASHING

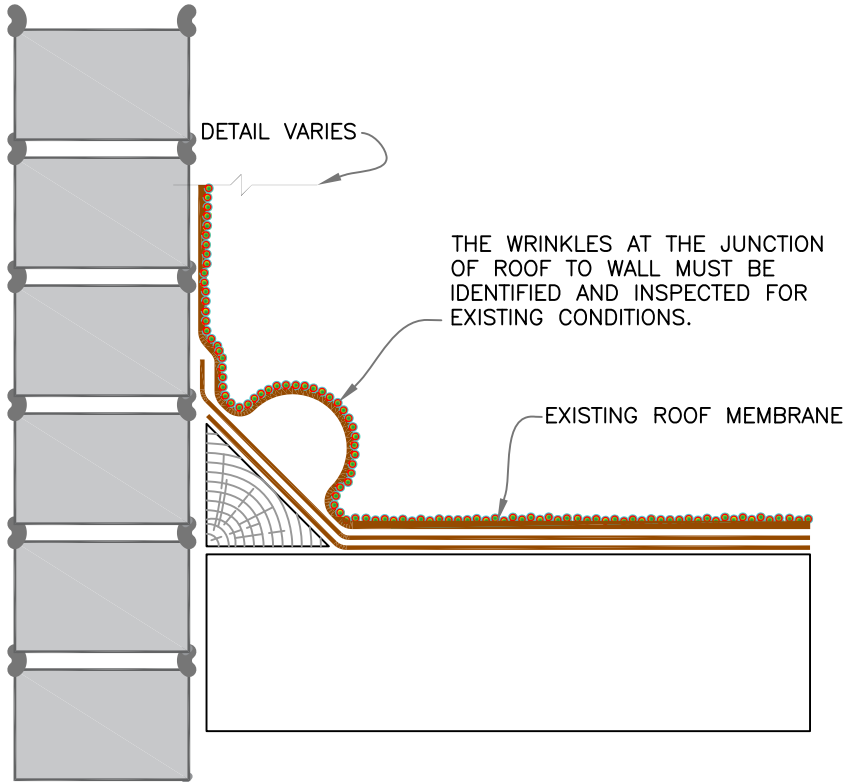

REPAIR & COATING

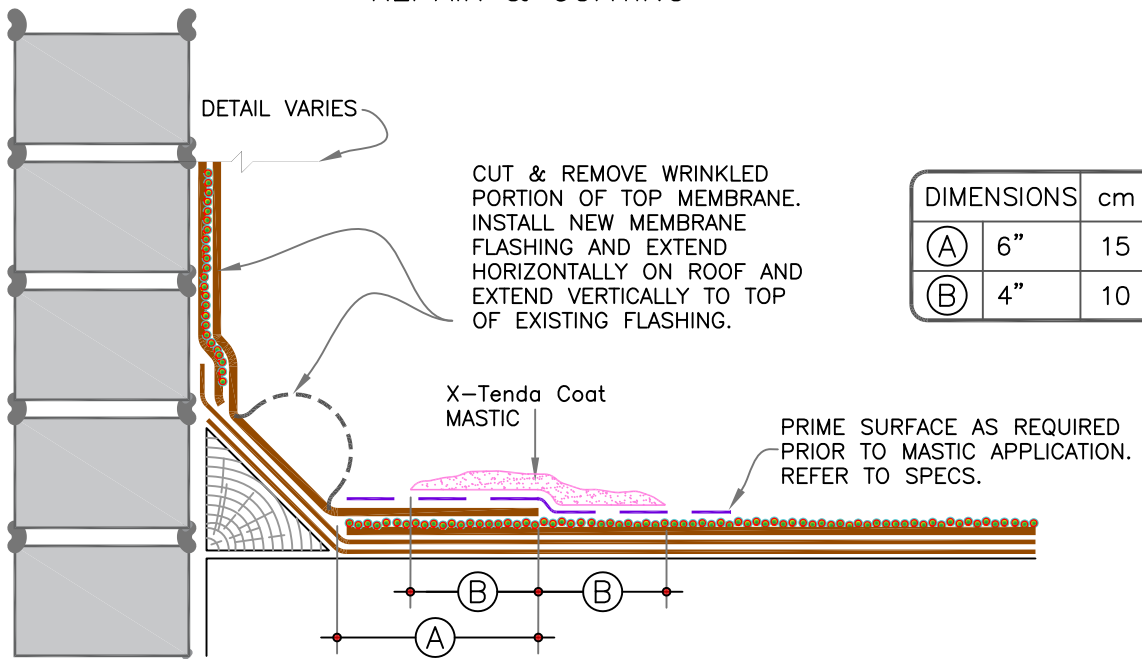

DIMENSIONS	cm	
(A)	6"	15
(B)	4"	10 MIN.

<p>VERSICO ROOFING SYSTEMS</p>	REPAIR: WRINKLES AT ROOF-TO-WALL JUNCTION	X-Tenda Coat
	NEW COATING ON EXISTING LOW SLOPE ROOFS	XCR-2D
<p>— X-Tenda Coat COATING</p> <p>— X-Tenda Coat PRIMER</p> <p>~ REINFORCEMENT</p> <p>█ X-Tenda Coat MASTIC</p> <p>0 NOTE(S)</p>	For additional information, refer to Specifications	

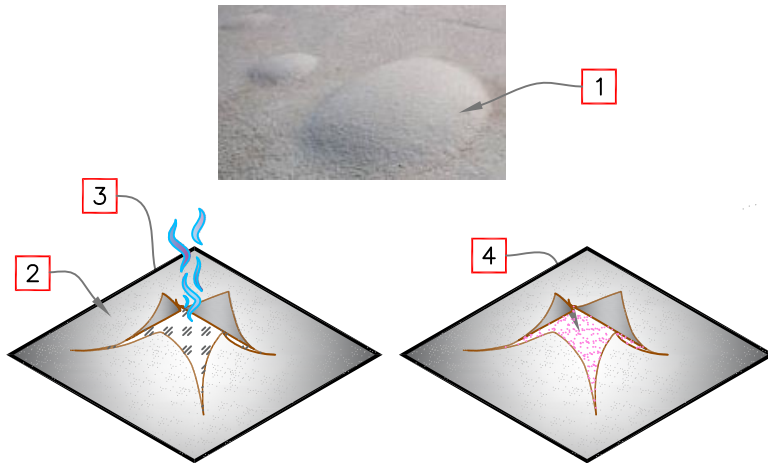

1. IDENTIFY BLISTERS AND WRINKLES IN THE FIELD AND MARK THEM WITH PAINT OR CRAYON.
2. MAKE A CROSS CUT WITHIN BLISTERED SURFACE & LIFT UP THE EDGES TO RELEASE THE AIR & MOISTURE. TRIM EDGES AS NEEDED.
3. REMOVE DEBRIS AND THOROUGHLY CLEAN THE BLISTERED AREA. ENSURE SURFACE IS DRY. PRIME SURFACES AS REQUIRED, REFER TO SPECS.
4. APPLY X-Tenda Coat MASTIC WITHIN THE CUT AREA. PUSH MASTIC UNDER THE LIFTED EDGES AND COMPLETELY EMBED ALL FOUR EDGES.

A

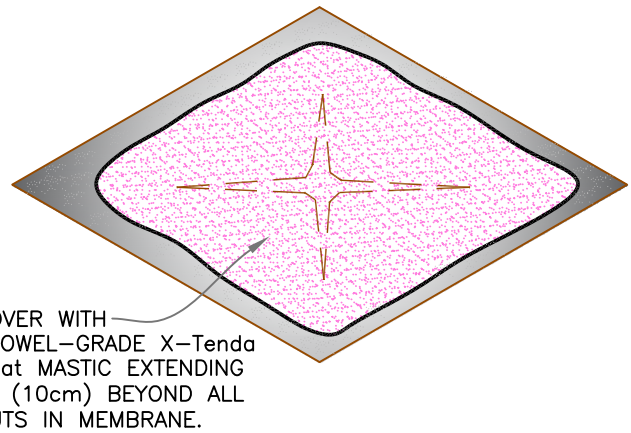
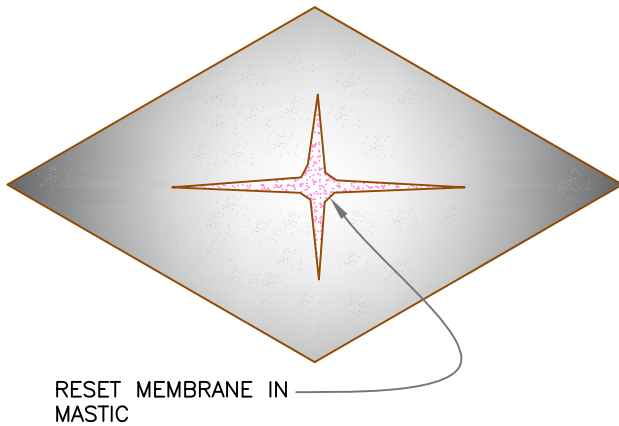

B

<p>VERSICO ROOFING SYSTEMS</p>	REPAIR – METHOD A (MASTIC): BLISTERS / WRINKLES	X-Tenda Coat
	NEW COATING ON EXISTING LOW SLOPE ROOFS	XCR-2E
	For additional information, refer to Specifications	
<p>— X-Tenda Coat COATING</p> <p>— X-Tenda Coat PRIMER</p> <p>~ REINFORCEMENT</p> <p>••••• X-Tenda Coat MASTIC</p> <p>0 NOTE(S)</p>		

ROOF RESTORATION WITH ELASTOMERIC COATING

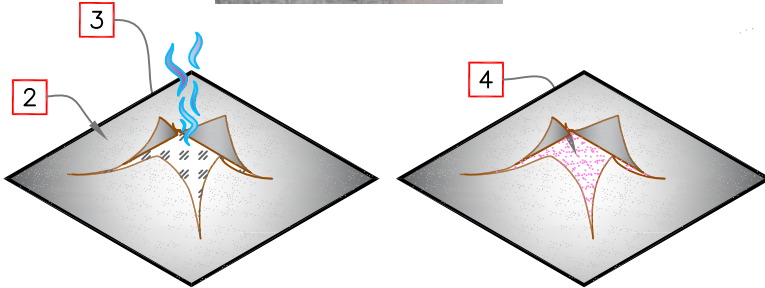

1. IDENTIFY BLISTERS AND WRINKLES IN THE FIELD AND MARK THEM WITH PAINT OR CRAYON.
2. MAKE A CROSS CUT WITHIN BLISTERED SURFACE & LIFT UP THE EDGES TO RELEASE THE AIR & MOISTURE. TRIM EDGES AS NEEDED.
3. REMOVE DEBRIS AND THOROUGHLY CLEAN THE BLISTERED AREA. ENSURE SURFACE IS DRY. PRIME SURFACES AS REQUIRED, REFER TO SPECS.
4. APPLY X-Tenda Coat MASTIC WITHIN THE CUT AREA. PUSH MASTIC UNDER THE LIFTED EDGES AND COMPLETELY EMBED ALL FOUR EDGES.

A

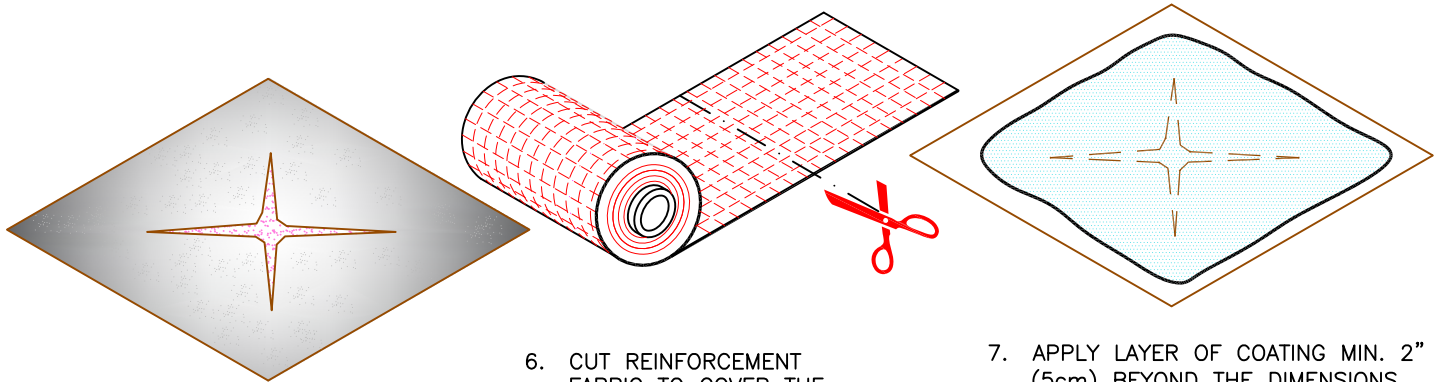

5. RESET MEMBRANE IN MASTIC

6. CUT REINFORCEMENT FABRIC TO COVER THE AREA. FABRIC SHALL EXTEND MIN. 2" (5cm) BEYOND THE CROSS-CUT LIMITS.

7. APPLY LAYER OF COATING MIN. 2" (5cm) BEYOND THE DIMENSIONS OF PRE-CUT REINFORCEMENT FABRIC.

B

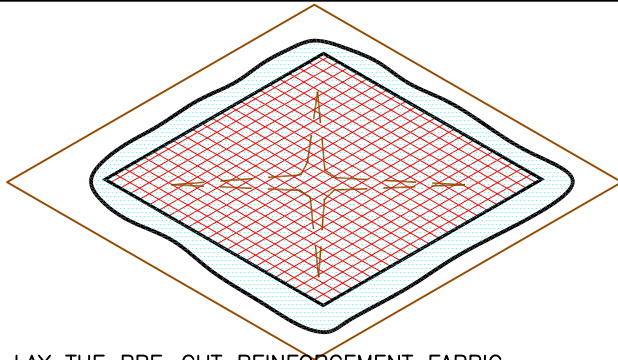

8. LAY THE PRE-CUT REINFORCEMENT FABRIC, CENTRALLY ALIGNED OVER BLISTER REPAIR. EMBED FABRIC IN BOTTOM COATING.

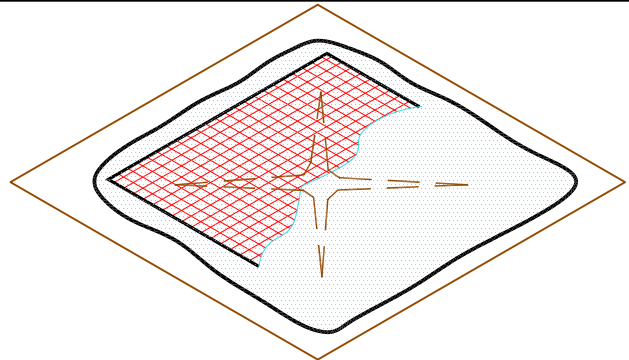

9. APPLY THE UPPER COATING A MIN. 2" (5cm) BEYOND THE WIDTH OF REINFORCING FABRIC.

C

<p>VERSICO ROOFING SYSTEMS</p> <p>— X-Tenda Coat COATING — X-Tenda Coat PRIMER — REINFORCEMENT</p> <p>— X-Tenda Coat MASTIC</p> <p>0 NOTE(S)</p>	REPAIR – METHOD B: (REINFORCING FABRIC) BLISTERS/WRINKLES	X-Tenda Coat
	NEW COATING ON EXISTING LOW SLOPE ROOFS	XCR-12
	For additional information, refer to Specifications	

A: 3D VIEW OF TYPICAL METAL ROOF

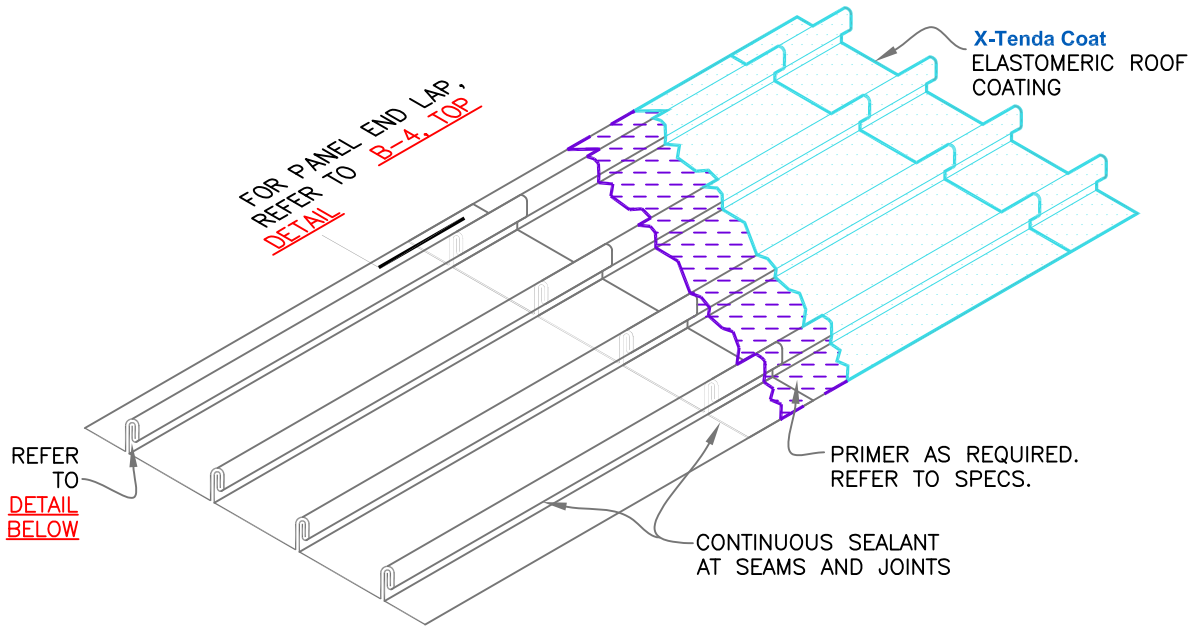

B: COATING DETAIL AT STANDING SEAM

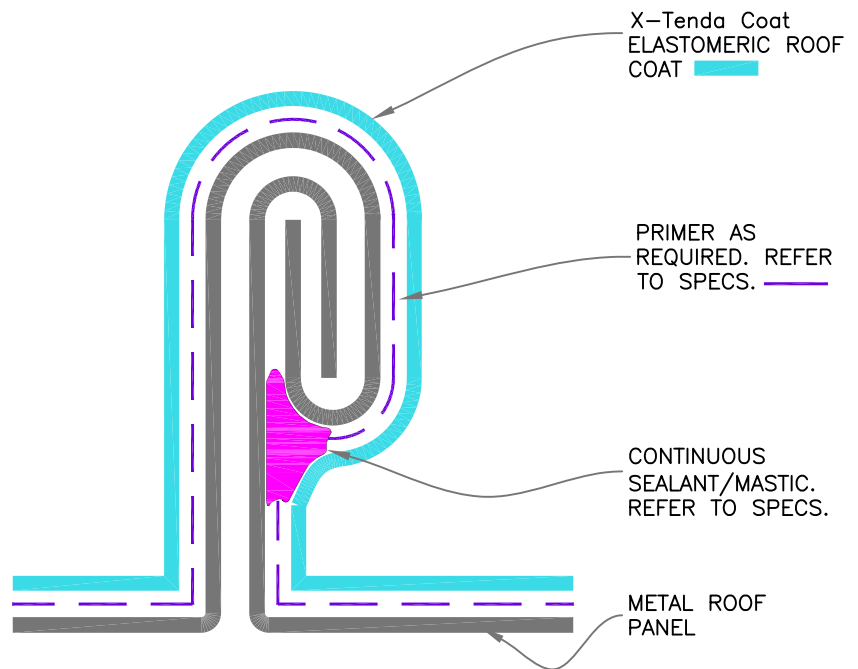

NOTE:

THIS IS A REFERENCE DETAIL DEPICTING A GENERIC STANDING SEAM OF METAL ROOF AND HOW TO TREAT IT PRIOR TO COATING PROCESS. SAME APPLIES TO OTHER SIMILAR SEAMS WITH DIFFERENT PROFILES SHOWN ON [B-2](#)

<p>VERSICO ROOFING SYSTEMS</p>	STANDING SEAM METAL ROOF COATING	X-Tenda Coat
	NEW COATING ON EXISTING METAL ROOFS	XCM-2A
<p>— X-Tenda Coat COATING</p> <p>— X-Tenda Coat PRIMER</p> <p>~ REINFORCEMENT</p> <p>█ X-Tenda Coat MASTIC</p> <p>0 NOTE(S)</p>	For additional information, refer to Specifications	

ROOF RESTORATION WITH ELASTOMERIC COATING

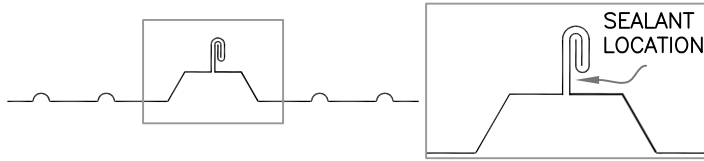

(A) TRAPEZOIDAL STANDING SEAM

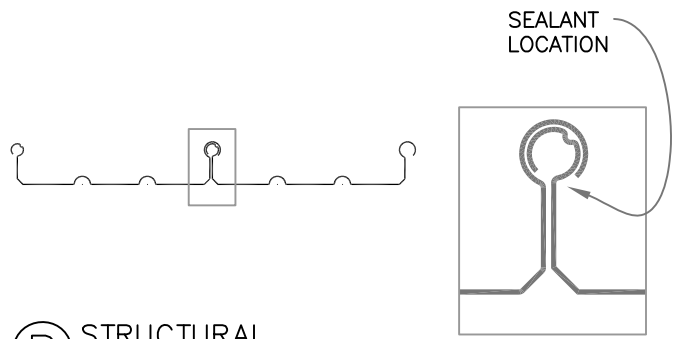

(B) STRUCTURAL STANDING SEAM ROOF

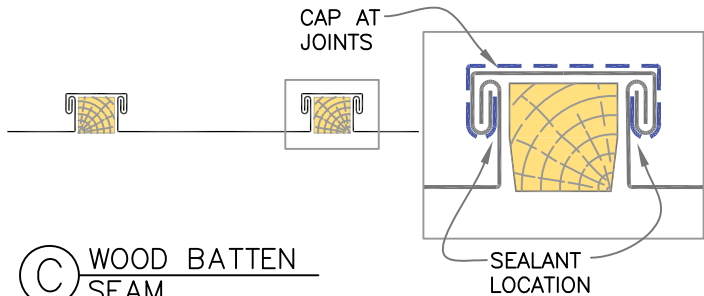

(C) WOOD BATTEN SEAM

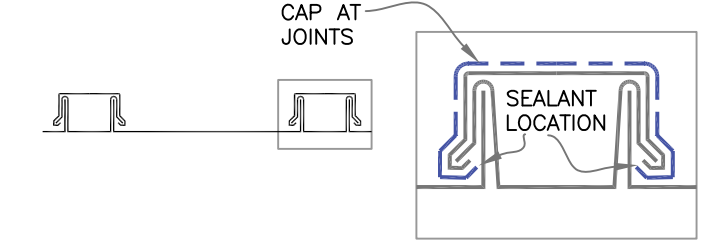

(D) APPLIED BATTEN SEAM

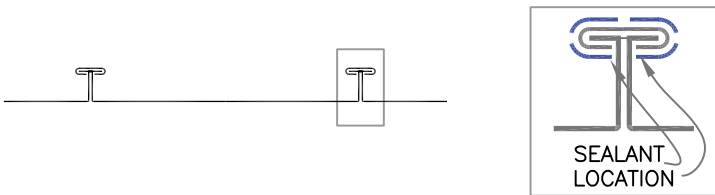

(E) TEE / CAPPED SEAM

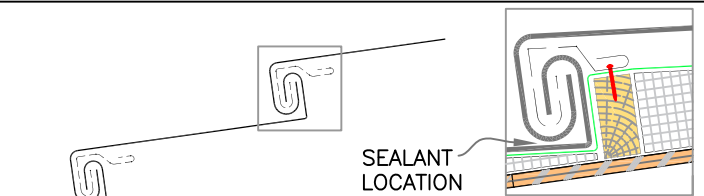

(F) BERMUDA TYPE ROOF (HORIZONTAL SEAMS)

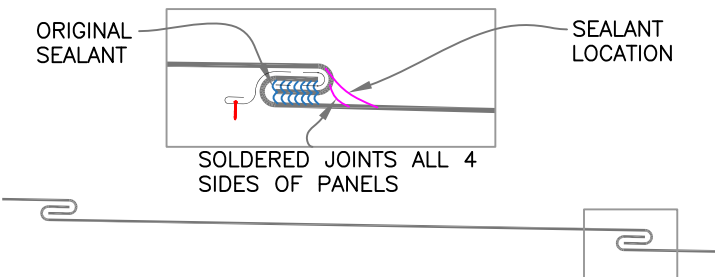

(G) LOW-SLOPE (FLAT) COPPER ROOF

NOTE:

FOR ADDITIONAL PROFILES, CONTACT X-TENDA COAT (X-Tenda Coat ROOF FOAM AND COATING)

<p>VERSICO ROOFING SYSTEMS</p>	METAL ROOF: SEAM TREATMENT OF VARIOUS PROFILES	X-Tenda Coat
	<p>NEW COATING ON EXISTING METAL ROOFS</p> <p>For additional information, refer to Specifications</p>	XCM-2B

- X-Tenda Coat COATING
- X-Tenda Coat PRIMER
- REINFORCEMENT
- X-Tenda Coat MASTIC
- NOTE(S)

DETAIL LOCATIONS

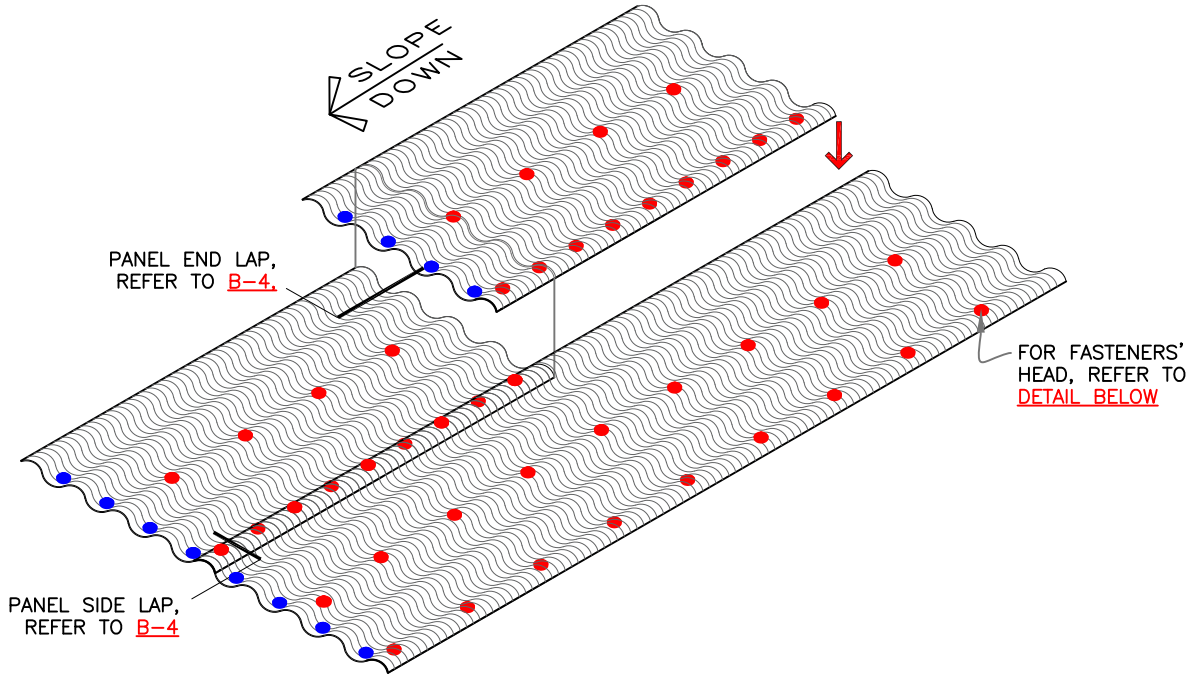

FASTENER HEAD TREATMENT PRIOR TO COATING

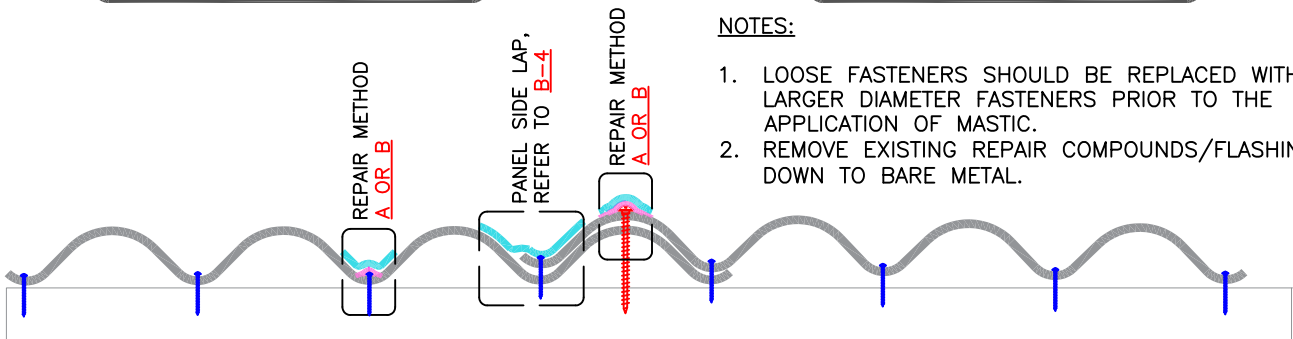
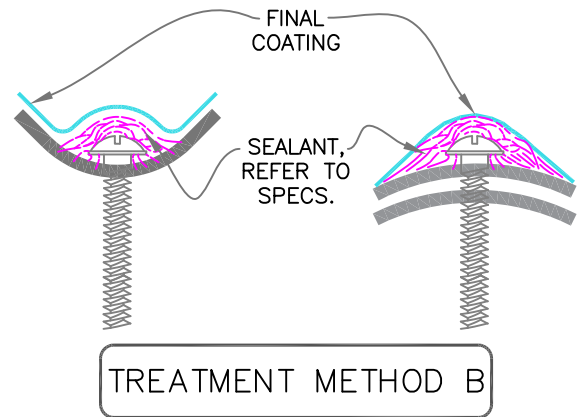
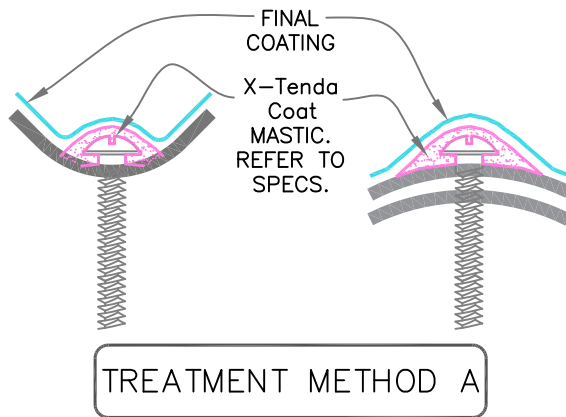

NOTES:

1. LOOSE FASTENERS SHOULD BE REPLACED WITH A LARGER DIAMETER FASTENERS PRIOR TO THE APPLICATION OF MASTIC.
2. REMOVE EXISTING REPAIR COMPOUNDS/FLASHINGS DOWN TO BARE METAL.

<p>VERSICO ROOFING SYSTEMS</p>	TREATMENT OF EXPOSED FASTENERS	X-Tenda Coat
	NEW COATING ON EXISTING METAL ROOFS	For additional information, refer to Specifications

PANEL END-LAP

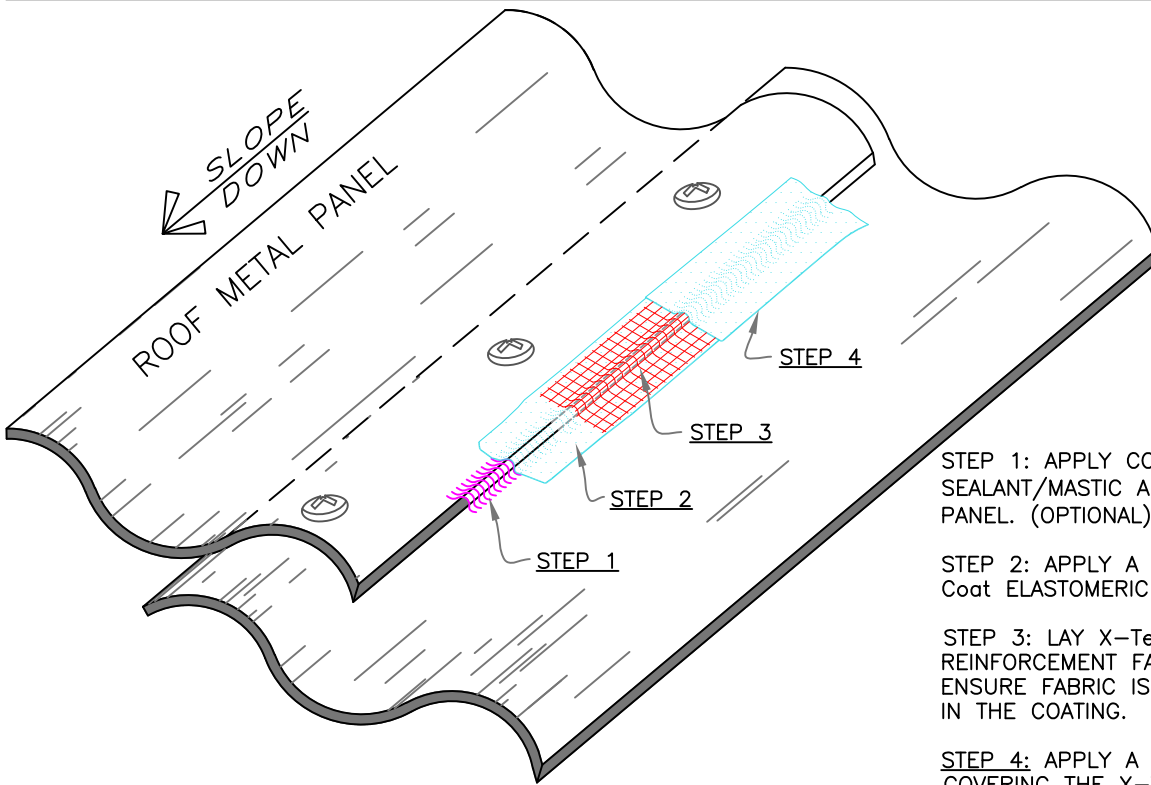
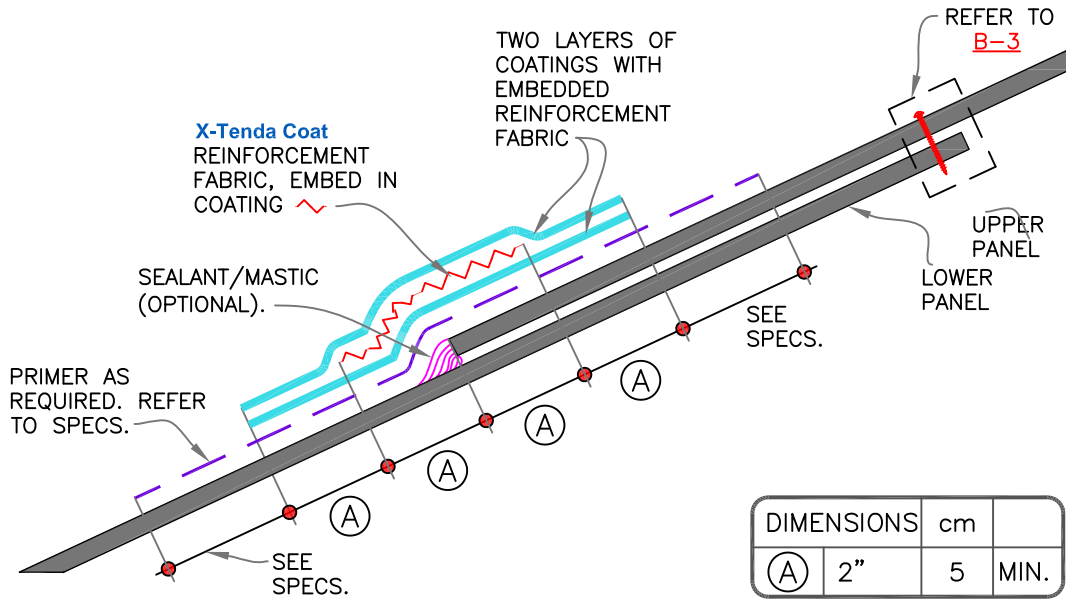

STEP 1: APPLY CONTINUOUS SEALANT/MASTIC ALONG THE EDGE OF PANEL. (OPTIONAL).

STEP 2: APPLY A LAYER OF X-Tenda Coat ELASTOMERIC COATING.

STEP 3: LAY X-Tenda Coat REINFORCEMENT FABRIC IN COATING. ENSURE FABRIC IS PROPERLY EMBEDDED IN THE COATING.

STEP 4: APPLY A 2ND LAYER OF COATING COVERING THE X-Tenda Coat REINFORCEMENT FABRIC AND SLIGHTLY EXTEND BEYOND THE BOTTOM COATING.

PANEL SIDE LAP

REFER TO **ABOVE** DETAIL FOR DIMENSIONS

<p>VERSICO ROOFING SYSTEMS</p> <p>X-Tenda Coat COATING X-Tenda Coat PRIMER REINFORCEMENT X-Tenda Coat MASTIC NOTE(S)</p>	<p>PANELS END LAP & SIDE LAP DETAILS</p> <p>NEW COATING ON EXISTING METAL ROOFS</p> <p>For additional information, refer to Specifications</p>	<p>X-Tenda Coat</p> <p>XCM-2D</p>
-----------------------------------------------------------------------------------------------------------------------------------------------------	----------------------------------------------------------------------------------------------------------------------------------------------------	-----------------------------------