

NOTES:

1. APPROXIMATELY 1/8" (0.5cm) DIAMETER BEAD OF CUT-EDGE SEALANT IS REQUIRED ON CUT EDGES OF REINFORCED TPO MEMBRANE.
2. WOOD NAILER MUST EXTEND PAST TOTAL WIDTH OF METAL FASCIA DECK FLANGE.
3. POSITION MEMBRANE WITH SELVAGE EDGE TO AVOID REMOVAL OF FLEECE BACKING.

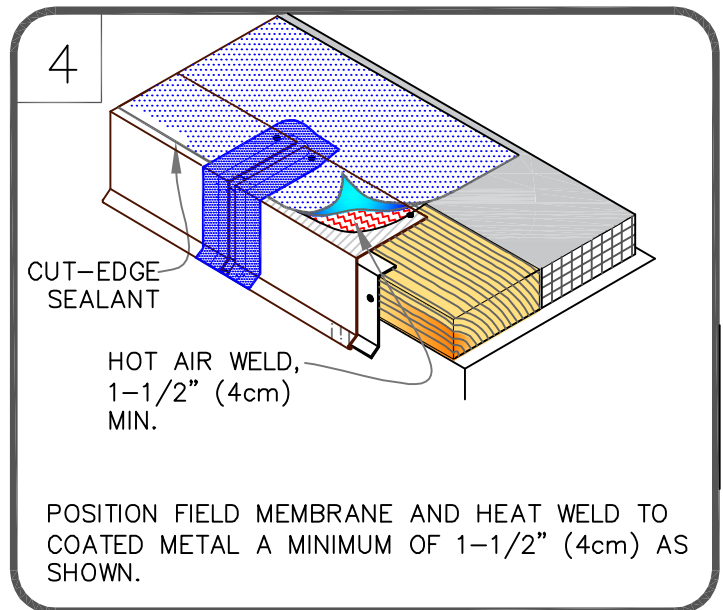
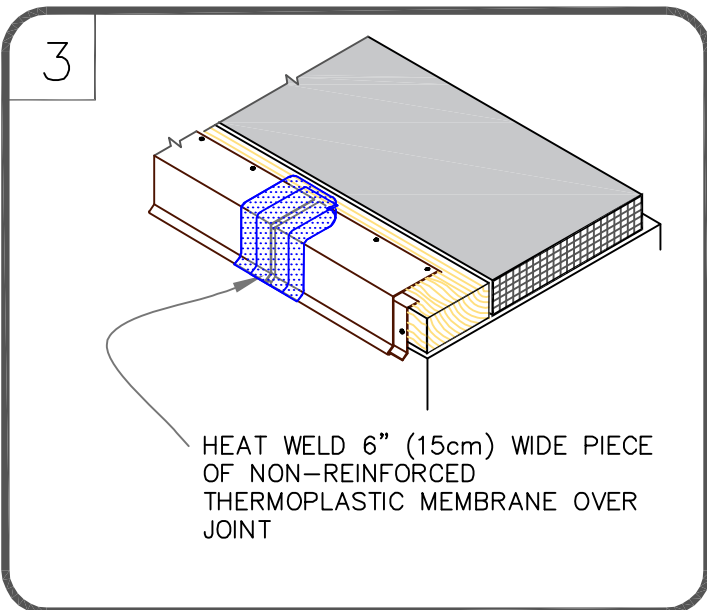
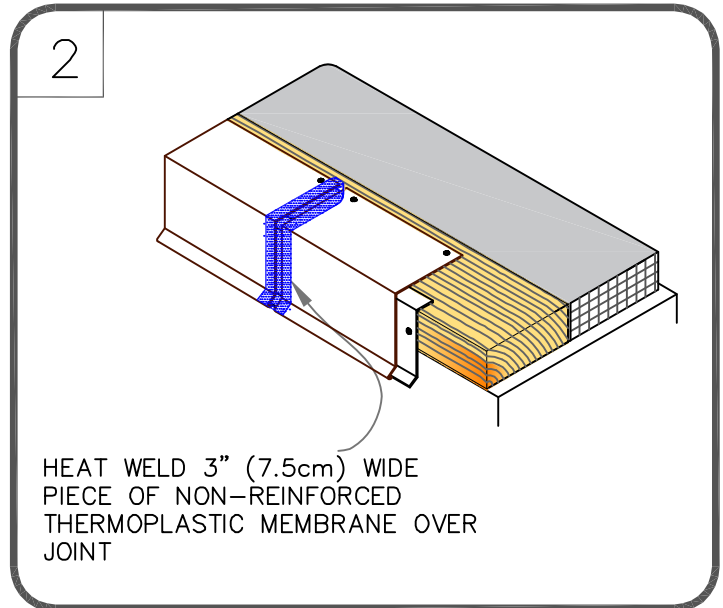
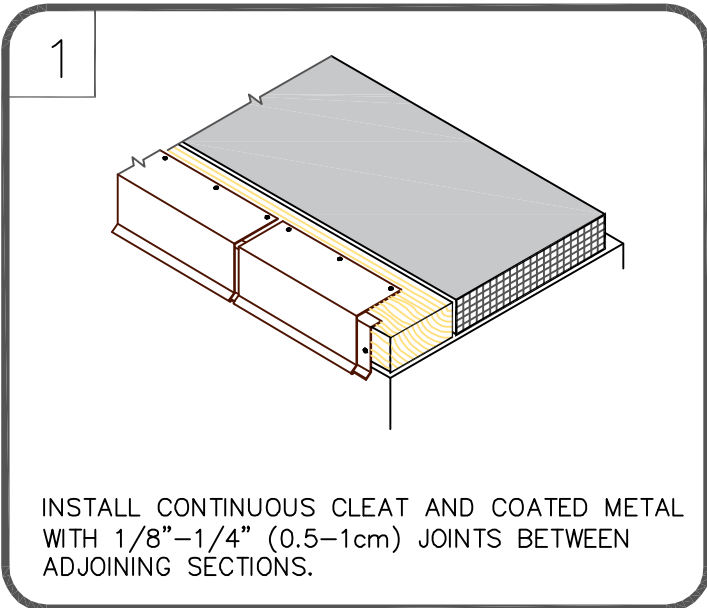

	COATED DRIP EDGE FASCIA - TPO, PVC OR KEE HP MAXIMUM WARRANTY: 30 YEARS	DETAIL NO. <b>FB-1B.1</b> FLEECEBACK ADHERED
--	--	--