



Quick Reference

Note: The drawing is for your records. Contractors should complete all repairs by the end of each work day.

When the roof has multiple levels, inspect one level at a time.

For larger roof levels, break into smaller sections to eliminate confusion.

NOTE: PVC PRESSURE-SENSITIVE COVER STRIP PRODUCT MUST BE USED IN CONJUNCTION WITH STEP 1 ACTIVATOR (BLUE IN COLOR) AND STEP 2 PRIMER.

Heat Welding Procedures:

Temperature setting for automatic welder:

PVC = 1148°F

All welds are a minimum 1 1/2" wide, regardless of warranty duration.

Bleed-outs should be present on edges of reinforced PVC membrane.

Minimum requirements for test welds: Perform a test weld at the start of work each morning and afternoon by using like material over the same substrate. *Versico does not require the use of destructive testing.*

Once cooled, peel the test sample apart to examine delamination of the membrane from the scrim reinforcement.

Welding Troubleshooting Checklist:

- Temperature and/or speed of welder
- Outside temperature (humidity and time of day)
- Heat transfer over insulation plates
 - Cold welds/voids can be found where seams cross over plates
- Cord size and length from source
- Generator size and wattage
 - Minimum 6500-watt generator for 1 automatic welder
 - Minimum 3000-watt generator for 2 hand welders
- Regular service/maintenance for welder
- Cleanliness of membrane
 - Proper cleaning materials/rags
 - PVC/KEE HP Membrane Cleaner on PVC & KEE HP systems
 - Scotch Brite Pad in conjunction with PVC/KEE HP Membrane Cleaner required on membranes exposed to sun for longer than 7 days
- Cleanliness of automatic welder/hand welder nozzle
- Check all start and stop points thoroughly

All seams must be probed prior to final inspection of the roofing system. Voids in the membrane must be repaired by the end of each work day.

Please consult Versico's Specification Supplement (section T-01-18) for more information about welding procedures, generator usage, and general troubleshooting.



IMPORTANT INFORMATION:

If you need assistance, it's only one call away.

Local FSR phone number:

Additional FSR phone number(s):

Sales Representative phone number:

Technical Sales Representative phone number:

Distributor phone number(s):

As a reminder, this guide is meant to help with details commonly seen in the field. Not all details are included in this guide. Versico contractors are encouraged to call with any questions.

For assistance, please call 1-800-992-7663 and choose option 2 or ask for the Technical Department.



A SINGLE SOURCE FOR SINGLE-PLY ROOFING
800.992.7663 • www.versico.com

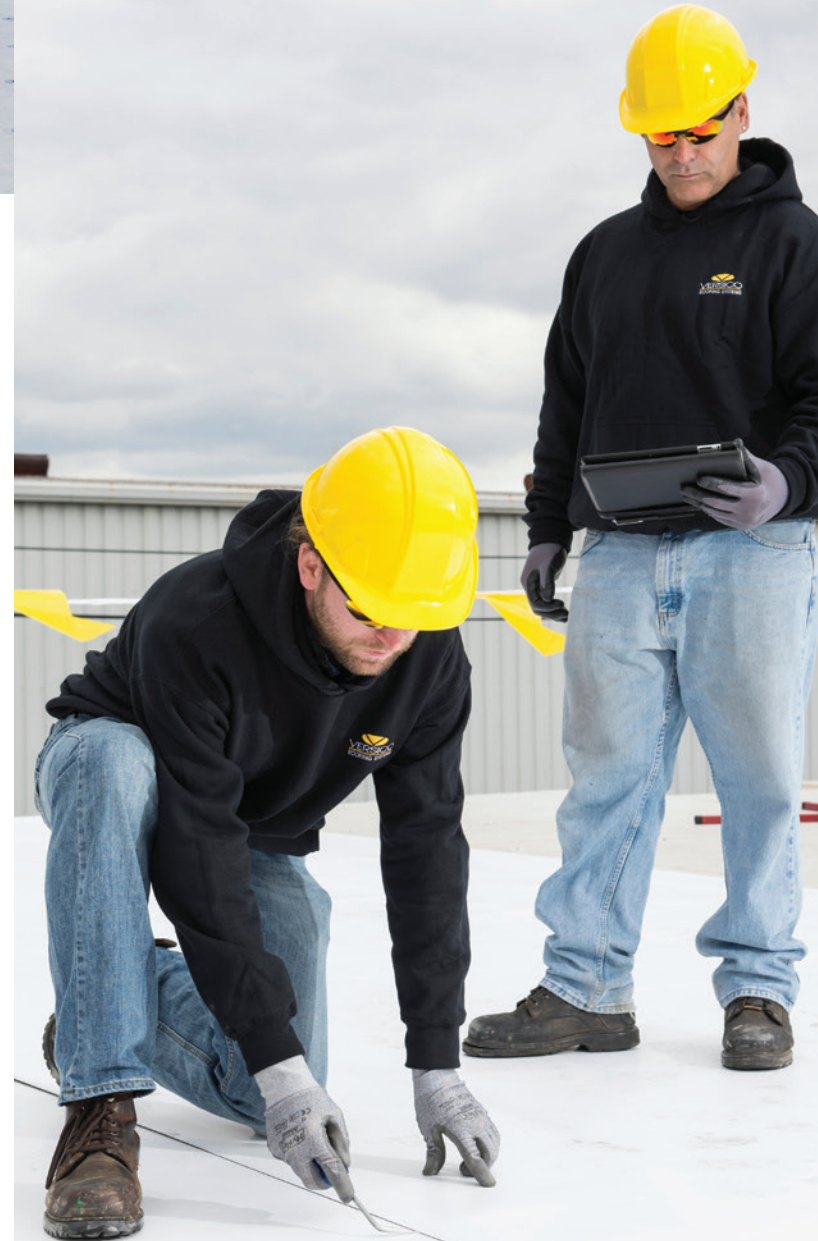

PVC/KEE HP (Thermoplastic) Rooftop Guide/Inspection Checklist

Guide for Inspecting Your System

This guide will illustrate the minimum requirements of a roof inspection and provide a basic understanding of some common details.

Below is a simple roof drawing with penetrations included. It shows the path followed by Versico Field Service Representatives (FSRs) when they inspect a roof for warranty.

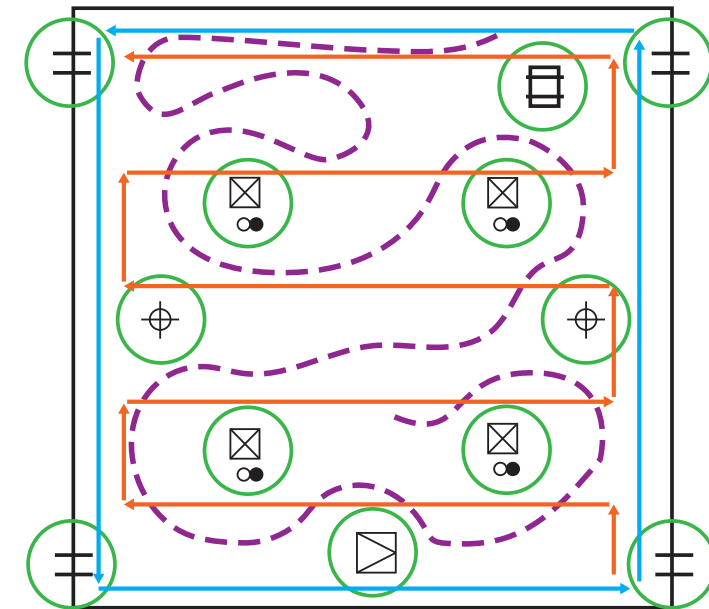

- | | | | |
|--|--------------------------|--|-----------|
| | - Roof Hatch | | - Scupper |
| | - Curb | | - Drain |
| | - Pipe | | - Sleeper |
| | - Pourable Sealer Pocket | | |

Step 1: Inspect the perimeter.

Update the roof plan to show the location of all curbs, penetrations, drains, etc. Focus on securement and termination. Mark deficiencies on the roof plan as they are found.

Step 2: Inspect all seams on the roof level.

Focus on plate placement and proper seaming.

Step 3: Inspect all curbs, penetrations, drains, etc.

Focus on one detail at a time, confirming proper securement, termination, and flashing minimums.

Step 4: Finally, walk across the roof, update areas in need of repair, and perform a general check of the system.

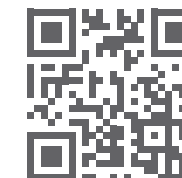

Scan the QR Code to view the Inspection Quick Reference Video

Common Details

TPC-1.2 VersiTrim™ Heat Weldable Drip Edge Fascia

1. Is wood nailer wider than metal flange?
2. Is wood nailer flush with insulation?
3. A continuous, minimum 22-gauge cleat and the metal must be fastened 6" OC using ring shank nails.
 - a. Install according to SMACNA ES-1 requirements.
4. Membrane covered past nailer heads a minimum of 2"? Is minimum 1½" weld present on the metal flange? Is bleed-out present?
5. Wood nailer must be properly secured/anchored (refer to FM 1-49).
6. Maximum ¼" gap between joints in metal overlaid with 2 layers of Non-Reinforced Flashing (first 3" wide, second 6" wide)?
7. Membrane weld onto coated metal: minimum 1½" hot air weld past fastener heads is required.

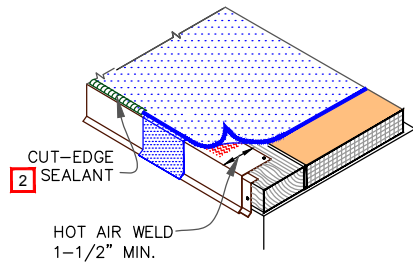

POSITION FIELD MEMBRANE AND HEAT WELD COATED METAL A MINIMUM OF 1-1/2" (38 mm) AS SHOWN.

TPC-1.2 VersiTrim Heat Weldable Drip Edge Fascia

TPC-1.3 VersiFlex™ PVC PS Cover Strip for Standard Drip Edge

1. Is the Cover Strip placed out to the edge of the metal?
2. Is Step 1 Activator extending out from the primer only on the PVC membrane?
3. Is the primer applied over the Activator and metal?
4. Is the Activator and Primer on the PS Cover Strip in all areas of overlap?
5. Is the material creased into the step off areas of overlap?

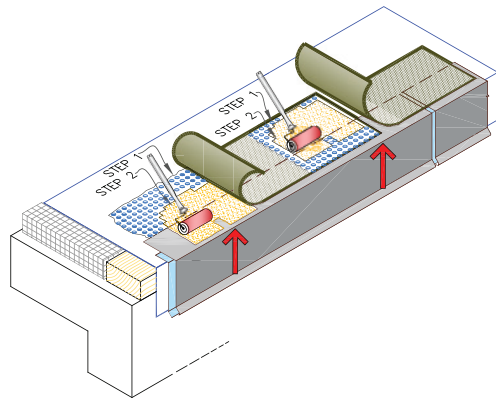

TPC-1.3 VersiFlex PVC PS Cover Strip for Standard Drip Edge

TPC-2.0/AC-2.2 Membrane Splice

1. Are all seams probed? Minimum 1½" weld achieved? Bleed-out present?
2. If reinforced edging is exposed, is ⅛" bead of Cut-Edge Sealant present? Note: this is recommended but not required for PVC systems.

3. For 60-mil and thicker membranes, are PVC T-Joint Covers present at field splice intersections?
4. On mechanically fastened systems, are HPVX Plates fastened minimum 12" OC within the field splice?

TPC-5.1 Curb Flashing

1. Is 1½" hot air weld past plates and fasteners present? Bleed-out present?
2. Is membrane properly terminated at the top of the curb?
 - a. Is counter-flashing used? If so, was it fastened with neoprene washers 12" OC?
 - b. Are fasteners present underneath metal counter-flashing?
 - c. Is Water Cut-Off Mastic present?
3. Membrane securement at inside angle changes?
4. Are outside corners complete?
5. On 60-mil and thicker membranes, have factory-fabricated T-Joint Covers been installed?
6. If Termination Bar is used, follow TPC-9.0 Details.

TPC-6.1 Drain Details

1. Are drain bolts or clamps in place to provide constant compression?
2. Hole in membrane must be larger than drain hole itself: minimum ½" from attachment points of clamping ring.
3. Is Water Cut-Off Mastic present between the cleaned drain bowl and the membrane?
4. If seams are present in drain:
 - a. Entire splice overlap at drain base must be hot air welded.
5. Drain ring must not be broken/cracked (must be replaced if found this way).

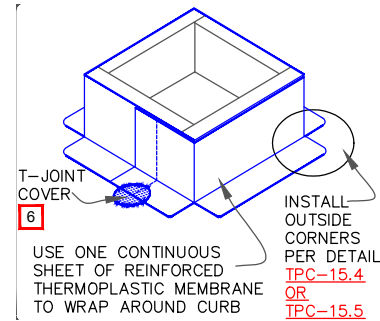

TPC-5.1 Curb Flashing

TPC-8 Pipes/Single Penetrations

Note: Temperature of pipes must not exceed 140°F. Field-fabricated Hot Stack must be installed per Detail TPC-8.5.

Pre-molded Pipe Flashing

1. Is it on a flat surface? Note: flanges cannot be overlapped.
2. Is cut in pipe boot above rib?
3. Are Water Cut-Off Mastic and clamping ring present at top of boot?

Field-fabricated Pipe Flashing

1. Are two wraps present?
 - a. Base wrap goes up pipe ½" minimum?
 - b. Top wrap overlaps base wrap 1" with a 1½" minimum splice on the vertical overlap?
 - c. Are Water Cut-Off Mastic and clamping ring present at top of field fabrication?
 - d. Fully adhered systems: Securement is required at penetrations greater than 18" in diameter. Mechanically fastened roofing systems: Securement is required at all penetrations.

TPC-9 Termination Bars

1. If warranty duration is 15 years or longer, Termination Bar must be present.
 - a. For warranties greater than 20 years, counter-flashing and Termination Bar must be used.
2. Is Water Cut-Off Mastic present?
3. Is Universal Single-Ply Sealant/sealant by others present at top of Termination Bar?
 - a. If counter-flashing is used, Universal Single-Ply Sealant/sealant by others is required at top edge of metal flashing, not on top of Termination Bar.
4. Termination Bar not bent around corners? Termination Bar must be cut and gapped.
5. Fastening of bar shall never exceed 12" OC and must always be sufficiently fastened to keep constant compression on Water Cut-Off Mastic.
6. Do not wrap Termination Bar around corners. Apply on hard, smooth surfaces only; not for use on exposed wood.
 - a. See Detail TPC-9.5 for additional requirements if Termination Bar is used at tilt-up panel joints.
 - b. Water Cut-Off Mastic must be installed at approximately 10' per tube.

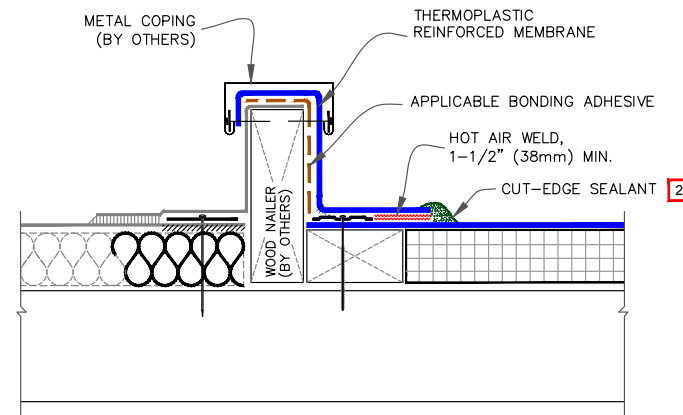

TPC-13 Tie-Ins to Existing Roofing System

TPC-12 Parapet/Curb Angle Change

1. Is securement present?
 - a. Appropriate fastening rate for required warranty? No more than 12" OC.
 - b. 6" OC for warranty wind speeds greater than 90 mph.
2. Are all flashings properly adhered?
 - a. Wall flashing securement is required if termination height is greater than 4'. See Detail TPC-12.4, 5.
3. When seam is present at angle change, there must be a 1½" weld.
 - a. If 1½" weld is not achieved, overlay using PVC Non-Reinforced Flashing with a minimum 1½" splice in all directions around the splice.
4. How is membrane terminated?
 - a. See Detail TPC-9.

TPC-15 Inside/Outside Corner

1. Is membrane securement present at the angle change?
2. Plates and fasteners 6"-9" away from Inside/Outside Corner?
3. Are plates and fasteners a minimum of 12" OC?

Note: 6" OC must be used when warranty wind speed is greater than 90 mph. See TPC-12 Details.
4. Pig ear fold in field-fabricated inside corner:
 - a. Fold on vertical wall and shedding water? 1½" weld achieved?

5. When flashing inside or outside corners, use one of the following:
 - a. PVC Inside Corners or PVC Outside Corners. Note: PVC accessory corners are not universal.
 - b. Or, when cutting your own 6" x 6" PVC Non-Reinforced Flashing:
 - i. Flashing must be formed before application of Inside or Outside Corners. See Details TPC-15.2 and 15.5.

TPC-16.1 Molded Sealant Pockets

1. For use on multiple hard-to-flash penetrations. Pipe clusters must have a minimum of 1" clearance between penetrations.
2. **Only the penetrations must be primed.** Everything else within Molded Sealant Pocket must be cleaned using PVC Membrane Cleaner.
3. Versico One-Part Pourable Sealer must be used: Filler by others is not allowed. Is Pourable Sealer at least 2" deep?
4. 1½" weld present on deck flange?
5. Securement is required on mechanically fastened systems: Not required on fully adhered systems.
 - a. On fully adhered systems, pockets larger than 18" in diameter must have plates and fasteners.

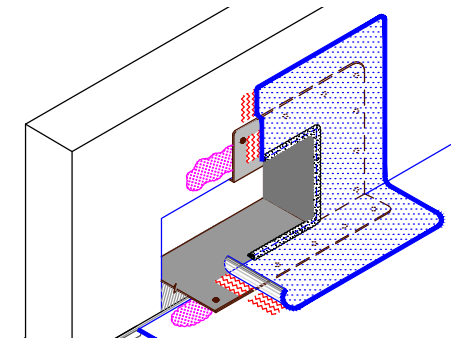

TPC-18.1 Scupper with Coated Metal

TPC-18 Metal Scupper

1. Scuppers can be flashed using PVC coated metal (TPC-18.1) or PVC Pressure-Sensitive Cover Strip (TPC-18.4).
2. Metal scupper box must have a continuous flange with rounded corners.
3. Is wood nailer present underneath metal?
4. Is Water Cut-Off Mastic present underneath metal?
5. Sealant by others required on outside of scupper where the scupper meets the outside wall.

VGC-24.0 Sleepers/Wood Blocking

1. Are slip sheets present underneath to prevent damage to new membrane?

Check usage of Walkway Rolls.

1. Present at all fixed access points, HVAC units that are regularly serviced, and concentrated walk areas?

A-27 Insulation Fastening

1. Is insulation fastened in accordance with current specifications and details?
2. Has proper fastener penetration been achieved?
3. Reduced fastening patterns are allowed on 22-gauge or heavier steel, concrete, minimum 1½" wood, and minimum ¾" plywood decks only.