

APPROXIMATELY
1/8" (0.5cm)
DIAMETER BEAD
OF CUT-EDGE
SEALANT IS
REQUIRED ON CUT
EDGES OF
REINFORCED TPO
MEMBRANE.

SECURWELD, HEAT
WELDABLE DRIP
EDGE FASCIA

MINIMUM
22-GAUGE
CONTINUOUS
CLEAT

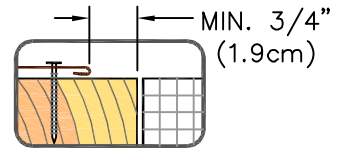
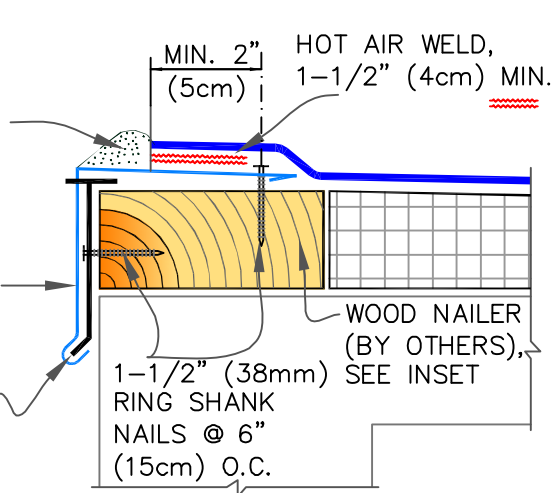

SEQUENCE:

1. 3" (7.6cm) REINFORCED MEMBRANE STRIPPING.
2. FIELD MEMBRANE.
3. TOP 6" (15.2cm) NON-REINFORCED MEMBRANE STRIPPING.

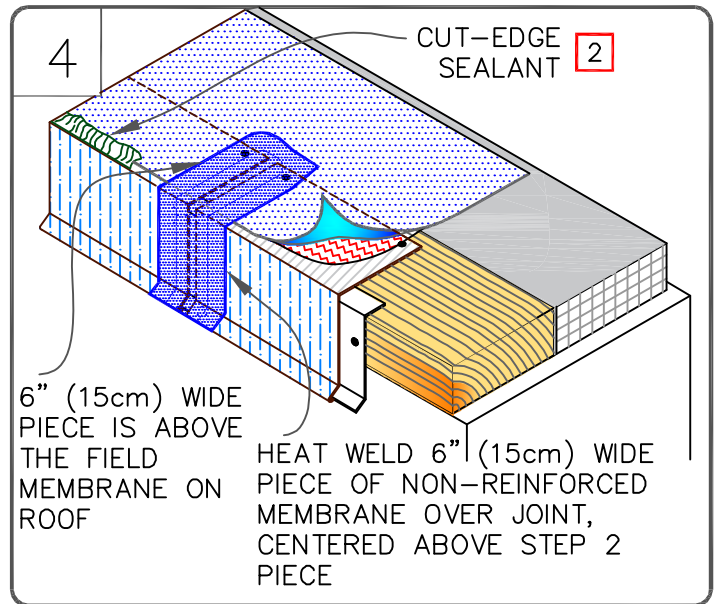
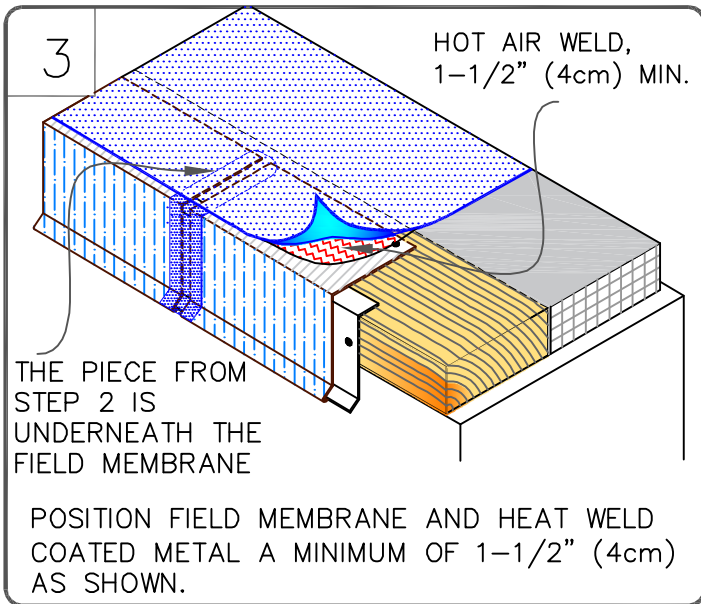
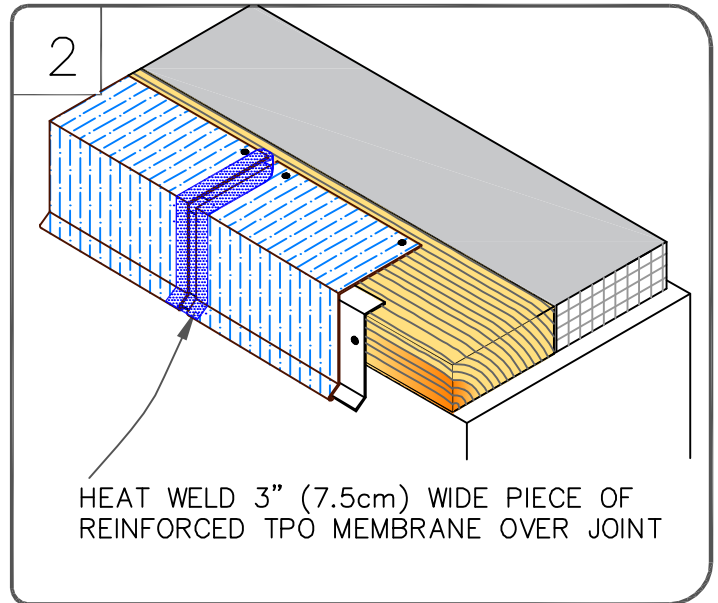
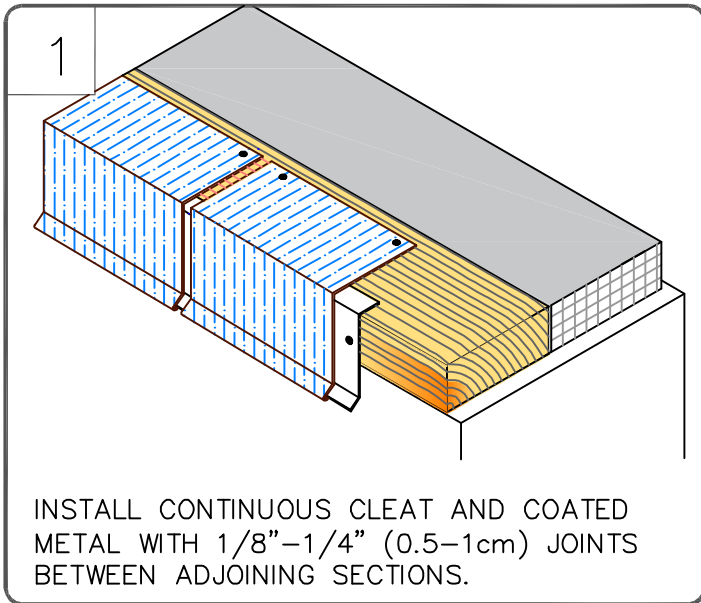

	SecurWELD COATED DRIP EDGE FASCIA		DETAIL NO.
	MAXIMUM WARRANTY: 30 YEARS		U-1B