



SPECIFICATION

SUPPLEMENT

Table of Contents

January 2024

The information contained in this generic specification represents a part of Versico's requirements for obtaining a roofing system warranty. Construction materials and practices, building siting and operation, climatic conditions, and other site-specific factors will have an impact on the performance of the roofing system. Versico recommends that the building owner retain a design professional to determine appropriate design measures to be taken in order to address these factors.

The information contained in these Supplements are to serve as a criteria for Specifiers and Authorized Contractors regarding the design and installation of Versico Roofing Systems and related products. Additional information essential for the design and installation of the roof systems mentioned herein are also included in the respective Specification for each Roof System and in the Design Reference Section of the Versico Technical Manual. Specifiers and Authorized Contractors are advised to reference all applicable sections.

General

VersiFleece Membrane and Insulation Attachment with Flexible DASH Adhesive.....	G-02-22
Fully Adhered Application Over Lightweight Insulating Concrete.....	G-03-20
Flashing Considerations /Metal Work.....	G-04-22
Roof Walkway Installation.....	G-05-21
Daily Seal / Clean Up.....	G-06-20
Application Procedures for 725TR Air and Vapor Barrier.....	G-07-20
Insulation Attachment and Details.....	G-08-23
Aqua Base 120 Bonding Adhesive.....	G-09-20
Metal Edging.....	G-10-18
LIQUISEAL Liquid Flashing.....	G-11-20
Application Procedures for VapAir Seal MD Air and Vapor Barrier.....	G-12-19
VacuSeal Vent Secure Roofing Systems.....	G-13-23
DeckVent Roof Assembly for Lightweight Structural Concrete Decks.....	G-14-21
Flexible DASH Adhesive Equipment and Set Up Requirements.....	G-15-22
Plaza Paver Systems.....	G-16-22
Electronic Leak Detection (ELD) Systems.....	G-17-24

Products

Related Products.....	P-01-22
-----------------------	---------

Thermoplastics

Heat Welding Equipment.....	T-01-23
-----------------------------	---------

EPDM

VersiGard Polyepichlorohydrin (ECO/CO) Membrane Installation Procedure.....	E-01-21
EPDM Membrane Splicing and Splice Repairs.....	E-02-20



SPECIFICATION

SUPPLEMENT

G-02-22

VersiFleece and Insulation Attachment and Coverage Rates with Flexible DASH Adhesive

January 2024

The information contained in this supplement serves as criteria for Specifiers and Authorized Contractors regarding the design and installation of Versico Roofing Systems and related products. Additional information essential for the design and installation of the Roof Systems mentioned herein are also included in the respective Specification for each Roof System and in the Design Reference Section of the Versico Technical Manual. Specifiers and Authorized Contractors are advised to reference all applicable sections.

A. General

Flexible DASH Adhesive may be used to attach the following roof insulations to an approved roof deck/substrate:

1. 1" (Min.) Polyisocyanurate, 1/2" SecurShield HD, 1/2" SecurShield HD Plus, 1.5" DuraFaceR, 1/2" DuraStorm VSH, 1/2" Versico Recovery Board, 1/4" Securock or minimum 1/4" DensDeck or DensDeck Prime or DensDeck StormX. If tapered Polyisocyanurate insulation is used, 1/2" minimum thickness is acceptable.
2. Expanded Polystyrene (EPS) insulation overlaid with SecurShield HD, 1/2" SecurShield HD Plus, Versico Recovery Board, Securock or DensDeck/DensDeck Prime. A composite board can be used to eliminate the need for an additional layer of Flexible DASH Adhesive.
3. Extruded Polystyrene insulation overlaid with 1/2" SecurShield HD, 1/2" SecurShield HD Plus, 1/2" DuraStorm VSH, Versico Recovery Board, Securock, or DensDeck/DensDeck Prime or DensDeck StormX.
4. When oriented strand board (OSB) is proposed as the membrane underlayment, a polyisocyanurate/OSB composite board may be used since attachment of individual OSB panels is not recommended due to board stiffness and potential bowing on uneven surfaces.

Insulation board sizes up to 4' x 8' may be used providing full attachment (full spray, equipment (rig) splatter, 4" or 6" o.c. extrusions) is achieved. Trimming or slitting of boards may be required on uneven surfaces. If necessary, use maximum 4' x 4' boards so full embedment of boards may be achieved.

B. Cautions and Warnings

1. Do not apply Flexible DASH Adhesive when surface and/or ambient temperatures are below 25°F (-4°C). The temperature of Flexible DASH Adhesive must be between 70°F (21°C) and 90°F (32°C), at the time of use. Use blanket heaters and hot boxes when necessary.
2. Flexible DASH may be applied when surface and/or ambient temperatures are below 25°F (-4°C) when heated equipment is used that includes the following: heated blankets, preheater, and heated hose.
3. When using Flexible DASH Adhesive in non-heated spray equipment, substrate and/or ambient temperatures must be between 25°F (-4°C) and 120°F (49°C).

4. **Bead Adhesive Spacing** – Beads must be applied following spacing approved for specific project conditions (i.e. height, wind zone, and warranty wind speed coverage).
- a. 12-inch on-center bead spacing is accepted in the field of the roof. Projects with higher wind speed coverage will require narrower spacing between beads.
 - b. Perimeter bead spacing is typically at 6-inches on-center except for those projects with higher wind speed coverage where narrower bead spacing of 4-inches on-center may be required.
 - c. Refer to [Detail A-27.7](#) (located in [Spec Supplement G-08-23](#)) and [Detail VF-27](#) in VersiFleece Specification for Membrane Attachment using Bead Adhesive approved by Versico or contact Versico prior to installation.
 - d. Substrate irregularity, which is commonly associated with gravel surfaced built-up roofing, must be compensated to ensure insulation boards are fully embedded. Do not apply thin beads of adhesive (less than 1/2-inch width wet bead for Non-Dual Tank Applications and 1.5" wide wet bead for Dual Tank Applications), and if necessary increase width of the adhesive bead in uneven areas.

5. **Residual Asphalt**

- a. **Incompatibility of the Substrate (Residual Un-Weathered Asphalt)** – While urethane adhesive is compatible with existing asphaltic roofs that have been exposed and weathered, it is difficult to adhere to **slick, smooth and un-weathered asphalt**. This condition may be encountered when an existing roof is removed, exposing an asphaltic vapor barrier or leaving asphalt residue.
- b. To ensure proper adhesive attachment, one of the following options may be followed:
 - 1) Prime the surface with Versico's CAV-GRIP 3V, CCW-702, CCW-702LV or CCW-702WB Primer for splatter and bead application.
 - 2) Switch to Full Spray of Flexible DASH Adhesive applied from heated spray rig to increase surface contact. 100% coverage is required. Splatter applications are not accepted.
 - 3) Install Versico's VapAir Seal 725TR Air & Vapor Barrier with CAV-GRIP 3V, CCW-702, CCW-702LV or CCW-702WB Primer over the existing asphalt.
 - 4) Use mechanical securement to attach the first layer of insulation in lieu of adhesive.

6. **Air Infiltration**

- a. On structural concrete decks, gaps between the structural deck and walls and those around penetrations, allows hot humid air from within the building to infiltrate the roofing assembly and possibly condense during the cold season. Lower membrane temperature, especially those associated with white membranes, increase the probability of condensation and promote freezing during low temperatures. Collected frozen moisture trapped above the structural deck when thawed, will eventually lead to weakening of the bottom insulation facer. Weakening of the bottom of the insulation facer can subsequently lead to separation of the foam during a wind event.

It is important to seal gaps around the perimeter and around penetrations, refer to [Design Reference DR-01-21 "Construction Generated Moisture"](#), to eliminate moisture infiltration.

- b. The same phenomenon with migrating moisture could occur on steel decks, where gaps are not sealed or vapor retarders are not used. In such a case, condensed moisture could result in insulation gapping, rusting of metal fasteners or steel decks and cause insulation to become wet. Refer to [Design Reference DR-01-21 "Construction Generated Moisture"](#).

C. **Roof Deck/Substrate Criteria**

Flexible DASH Adhesive can be used to attach insulation to new or tear-off construction over structural concrete, fibrous cement (i.e., Tectum), gypsum, cellular or perlite lightweight insulating concrete (min. 225 psi compressive strength), wood and steel decks.

Flexible DASH Adhesive may also be used to attach insulation to an existing asphalt or coal tar pitch, modified bitumen or mineral surfaced cap sheets as follows:

1. On tear off projects, the existing roof deck must be investigated and all wet and deteriorated material must be replaced. All loose base sheet material or asphalt must be removed prior to Flexible DASH Adhesive application.
2. The deck surface must be cleaned using compressed air, vacuum equipment or hand/power brooms to remove dust, loose dirt or debris. If excessive dust or dirt is present, a primer may be required prior to application of the adhesive. Contact Versico for specific primer requirements.
3. For new galvanized steel decks, power washing is required to remove finishing oils, if present.
4. For projects with existing Type III or IV asphalt, coal tar pitch, modified bitumen or mineral surface cap sheets, the existing roof must be inspected to determine if moisture is present within the existing assembly. Wet insulation and membrane shall be removed and replaced with compatible materials.
 - a. Blisters, buckles, wrinkles and fishmouths shall be cut out or mechanically fastened.
 - b. Remove loose gravel, dust and residue from a gravel surfaced BUR by using a Hydro-Vac (wet vacuum equipment). Power vacuum equipment or a power sweeper followed by air blowing or another suitable means are also acceptable. Care shall be exercised in areas where evidence of ponding is obvious (remove residue from low areas prior to proceeding).

CAUTION: On coal tar pitch, when using white membrane, minimum 1" thick polyisocyanurate is the required membrane underlayment. If gray or tan membrane is used, minimum 1.4" thick polyisocyanurate is required.

D. Adhesive Coverage Rates

1. The overall coverage rate for Flexible DASH Adhesive will vary depending on jobsite conditions, product container size, and the substrate as follows:

Flexible DASH Adhesive Coverage Rates					
Approximate Coverage Rate (Sq. Ft.)					
Package Type	Full Spray	Splatter	4" o.c.	6" o.c.	12" o.c.
Dual Cartridges	N/A	N/A	100-200	200 -300	400 - 600
Dual Tanks	N/A	2,600-2,800	1,100-1,300	1,700-1,900	3,500-3,700
5-Gallon Jugs	1,000	1,800-2,000	670 - 900	1,000 - 1,250	2,000 - 2,500
15-Gallon Drums	1,800-3,000	5,400-6,000	2,110-2,700	3,000-3,750	6,000-7,500
50-Gallon Drums	5,000-10,000	18,000-20,000	6,700 - 9,000	10,000 - 12,500	20,000 - 25,000



Fig 1. Full Spray Application

2. Full Spray Application and Coverage Rates (See Figure 1 above)

- a. Flexible DASH is to be dispensed by the appropriate spray rig and gun to achieve 100% coverage of the substrate at a rate of 1 gallon per 100 square feet. Substrate irregularity, which is commonly associated with gravel surface, built-up roofing, may take up to 2 gallons per square to compensate so the insulation boards are fully embedded in tot the Flexible DASH.
- b. To achieve proper coverage, spray in a horizontal, sweeping motion, overlapping each new pass with the previous pass by 50%.



Fig 2. Bead Application

3. Bead Application and Coverage Rates (See Figure 2 above)

- a. Flexible DASH is to be dispensed in ribbons or beads to achieve spacing approved for specific project conditions (i.e. height, wind zone and warranty wind speed coverage).



Fig 3. Correct Coverage – Splatter Application



Fig 4. Light Coverage – Splatter Application

4. Splatter Application and Coverage Rates (See Figures 3 and 4 above)

a. Spray Rig and Gun

- 1) Flexible DASH is to be dispensed by the appropriate spray rig and gun to achieve 50% coverage of the substrate at a rate of 1/2 gallon per 100 square feet.
- 2) To achieve proper coverage, spray in a horizontal, sweeping motion, from a minimum 24" height, overlapping each new pass with the previous pass by 50%.
- 3) Adhesive should be applied in large droplets, not a fine mist. Air pressure is too high if the adhesive is in a fine mist.

b. Dual Tanks

- 1) Flexible DASH is to be dispensed using Dual Tanks to achieve 50% coverage of the substrate at a rate of 3.75 lbs per 100 square feet.
- 2) To achieve proper coverage, spray in a horizontal, sweeping motion, from a minimum of 24" height, overlapping each new pass with the previous pass.
- 3) When applying, the 14" extension nozzle should NOT be used.

E. Installation Criteria

1. Check to ensure the substrate is dry. Flexible DASH Adhesive cannot be applied to a wet or damp surface.
2. Dispense Flexible DASH Adhesive over the dry substrate area at the coverage rate indicated previously to allow for full coverage, splatter or proper bead spacing.



3. Allow the adhesive to rise up approximately 1/4" to 3/4", depending on dispensing method, and develop strings prior to setting insulation boards into adhesive.

Note: String-time is measured by touching the adhesive with a splice wipe and looking for development of "strings" of adhesive as you pull the splice wipe out of the adhesive. With Flexible DASH Adhesive, string time is generally around 1-1/2 – 2 minutes after application at room temperature.

4. Walk the boards into the adhesive and roll using the 30" wide, 150 lb weighted segmented steel roller to ensure full embedment. The proper roller can be purchased from Rooftop Equipment or one of their distribution partners. Optimal set up time should be approximately 5 to 7 minutes.

CAUTION: Walking on the boards immediately after placement in adhesive can cause slippage/movement until the adhesive has started to set up. On roofs with a slope greater than 1/2" in 12", begin adhering insulation at the low point and work upward to avoid slippage. One person should be designated to walk/roll in all boards and trim/slit or apply weight as needed to ensure adequate securement.

CAUTION: If boards easily slide, string time has not been achieved.

5. Position all edges of the boards on the top flutes of steel decks for adequate support.
6. If multiple layers of insulation are specified or required, spray, equipment (rig) splatter or bead-apply Flexible DASH Adhesive over the base layer once fully secured and follow procedures noted above for attachment of each insulation layer.

Copyright 2024 Versico

Versico and Flexible DASH Adhesive are Trademarks of Versico

DensDeck and DensDeck Prime is a Trademark of Georgia-Pacific Gypsum LLC

This Spec Supplement represents the applicable information available at the time of its publication. Owners, Specifiers and Versico authorized roofing contractors should consult Versico or their Versico Independent Sales Representative for any information that has subsequently been made available.

Review the appropriate Versico Warranty for specific warranty coverage, terms, conditions and limitations.



SPECIFICATION

SUPPLEMENT

G-03-20

Fully Adhered Applications Over Lightweight Insulating Concrete For EPDM, TPO and VersiFleece Membranes

January 2024

This supplement is to serve as criteria for Specifiers and Authorized Contractors regarding Direct Application Over Lightweight Insulating Concrete. For installation details Specifiers and Authorized Contractors are advised to reference all applicable technical manuals/details or the Versico website.

When specified, the EPDM and TPO membranes or VersiFleece (TPO, PVC or KEE HP) membrane may be fully adhered directly to an approved **cellular or perlite lightweight insulating concrete** with a minimum compressive strength of 225 psi.

- A. EPDM membrane can be fully adhered with Versico's EPDM Bonding Adhesive. Versico's TPO Bonding Adhesive shall be used when using TPO membrane. Maximum warranty available (Non-VersiFleece membrane) for direct application is 15 year with peak gust wind speed of 55 mph.
- B. Flexible DASH Adhesive must be used when VersiFleece (TPO, PVC or KEE HP) membrane is specified. Maximum warranty available with VersiFleece 115-mil membranes for direct application is 20 year with peak gust wind speed of 80 mph.
- C. For direct application over **cellular** lightweight insulating concrete, Aqua Base120 can be used as a two-sided contact adhesive with Non-VersiFleece (EPDM, TPO or PVC) membrane. When Aqua Base 120 Bonding adhesive is specified refer to [Spec Supplement G-09-18 "Aqua Base 120 Bonding Adhesive"](#) for Warranty information.

Note: Use of VersiFleece membranes in conjunction with Water Based adhesives over lightweight insulating concrete is not permitted.

Non-VersiFleece membranes are not to be fully adhered directly to **vermiculite lightweight insulating concrete**. When a VersiFleece membrane is to be fully adhered directly to **vermiculite lightweight insulating concrete**, Versico must be contacted to determine applicable requirements pertaining to priming, venting, warranty duration and wind speed coverage.

Projects where the VersiFleece membrane has been approved will be limited to a wind speed coverage of 55 mph peak gust wind speed unless otherwise approved by Versico.

The Authorized Contractor must provide Versico with a copy of a certification letter from the lightweight insulating concrete manufacturer (on new construction projects), which references the project name and location and contains the manufacturer's brand name, minimum compressive strength, average wet and air dry densities.

Application Cautions

1. The substrate must be dry, free of debris, fins, frost, loose and foreign materials. Fill any gaps in the substrate greater than 1/4" with Flexible DASH Adhesive or VapAir Seal 725TR or VapAir Seal MD (when VersiFleece membrane is to be used or other appropriate material).

2. Do not proceed with membrane installation until the lightweight insulating concrete has cured a minimum of 48 hours. If necessary, consult with the lightweight insulating concrete manufacturer concerning additional drying time.
3. After rain or other precipitation, follow the manufacturer's requirements concerning proper visual inspection and additional drying time prior to adhering the membrane.
4. Prior to membrane installation, darker areas, especially along hairline cracks in the concrete, may serve as an indication of moisture entrapment and possible standing water beneath the surface. If this condition is found, consult with the lightweight insulating concrete manufacturer for proper corrective measures.
5. Except when lightweight insulating concrete is poured over slotted steel decks, the authorized roofing contractor must conduct core cuts at the minimum rate of 1 every 2,000 square feet. The core cuts should be located around hairline cracks (if present) where darker areas are visible. After core cuts have been taken, the substrate must be examined for evidence of moisture above the structural deck and, if found, a wet/dry vacuum system, as recommended by the lightweight insulating concrete manufacturer, must be utilized to remove standing water from beneath the surface of the concrete.
 - a. To ensure the efficient operation of the vacuum system, a tight seal must be provided between the nozzle of the vacuum and the lightweight concrete substrate.
 - b. Versico's Non-Weldable or Weldable, One-Way Pressure Relief Breather vents, must be installed over each core cut in accordance with Versico Detail. See [Spec Supplement P-01-20 "Related Products"](#) for more information.

Copyright 2024 Versico

Versico, VersiWeld, Flexible DASH and VersiFleece are Trademarks of Versico

This Spec Supplement represents the applicable information available at the time of its publication. Owners, Specifiers and Versico authorized roofing contractors should consult Versico or their Versico Independent Sales Representative for any information that has subsequently been made available.

Review the appropriate Versico Warranty for specific warranty coverage, terms, conditions and limitations.



SPECIFICATION

SUPPLEMENT

G-04-22

Flashing Considerations / Metal Work

January 2024

This supplement is to serve as criteria for Specifiers and Authorized Contractors regarding flashing of walls, curbs, metal work, pipes, drains and other penetrations for EPDM, Thermoplastics, AC and VersiFleece membranes. For individual roofing system information, Specifiers and Authorized Contractors are advised to reference the appropriate roofing system specification and associated roofing details.

A. General Flashing Considerations

1. For projects specified with a greater than 20 year membrane system warranty, Versico's Termination Bar in conjunction with Water Cut-Off Mastic, must be specified under all metal counterflashings. Refer to applicable Versico Detail.
2. The height of the new wall flashing and termination must extend above the anticipated water level (due to heavy rain) or slush line (due to water under accumulated snow).
3. All existing loose flashing must be removed prior to the application of new membrane. New membrane flashing must extend above all existing intact flashing but must not conceal weep holes or cover existing through wall counterflashing.
4. Install surface mounted reglets and compression bar terminations directly to the wall surface.
5. Bitumen based roof cement must be removed or concealed with an acceptable underlayment.

CAUTION: Residual asphalt left on walls and curbs could cause discoloration of white membranes. All residual asphalt must be primed with one of the following, CAV-GRIP 3V, CCW-702, CCW-702LV or CCW-702WB primer for further information refer to [Spec Supplement G-02-22 'VersiFleece Membrane and Insulation Attachment with Flexible DASH Adhesive'](#).

6. It is highly recommended for all deck to wall joints, vertical joints between tilt up panels, and any gaps in metal walls to be sealed to prevent any moisture infiltration and possible condensation beneath the membrane. Unsealed joints must be brought to the attention of the Specifier for assessment and proper detailing.
7. The Specifier must examine structural supports for rooftop equipment to determine if reasonable access to the membrane beneath the equipment is provided.
8. When sleepers are used for mounting rooftop equipment, they must be designed to provide adequate support. An appropriate detail must be selected to prevent depression of the insulation and possible damage to the membrane. Caution is to be exercised for sleeper mounted pipes and gas pipes could shift due to heavier snow accumulation on white roofs, due to lack of solar gain. Designer or Specifier may opt to use structurally secured mounting system or possibly increase sleeper height to reduce the force of sliding snow. Periodic snow removal to reduce accumulation is strongly recommended especially on sleepers running perpendicular to roof slope.
9. Depending on the type of the existing roofing system, the tie in method will vary. Total isolation between the two roofing systems or weep holes may be required to address moisture migration from one roofing system to the other. For PVC membrane total isolation between the two roofing systems is required.
10. Flexible penetrations (braided cables, conduits, wires, etc.) must be enclosed in a stable gooseneck.

11. Hot pipes exceeding the temperatures greater than those included in the “chart” below must be insulated with metal collars and rain hoods. Ensure that rain hood does not fit snug around insulated collars to allow for adequate air circulation and prevent heat transfer.

Hot Pipe Limitations	
Membrane	Temperature
EPDM	180°F
TPO	160°F
PVC	140°F

- 12. On Mechanically Attached assemblies, additional membrane securement is required around pipes and sealant pockets as shown on applicable details. Fastening plates must be positioned a maximum of 12" away from the penetration, spaced a maximum of 12" on center and flashed in accordance with the applicable Versico Detail.
- 13. When VersiFleece or an AC membrane is specified, at roof drains and compression seal terminations such as terminations bars and coping stones, the fleece backing must be removed from the back of the membrane so Water Cut-Off Mastic can be applied directly to the membrane surface.

B. Application of Flexible DASH for Vertical Walls

- 1. Flexible DASH must be applied directly to the wall in a spray method out of high pressure dispensing equipment. Bead/splatter methods are not allowed for wall application.
- 2. Wait for proper string time and apply the VersiFleece membrane to the vertical substrate. Apply pressure to the VersiFleece membrane adhered to the wall with a roller.

C. Application of CAV-GRIP 3V for Vertical Walls

- 1. CAV-GRIP 3V may be used as a contact adhesive to apply VersiFleece TPO/PVC/KEE HP or bareback EPDM/TPO membranes (not for use with bareback PVC or KEE HP) to vertical walls.
- 2. Application of CAV-GRIP 3V shall be applied continuously with 50 percent overlap on each pass.

D. Application of CAV-GRIP PVC for Vertical Walls

- 1. CAV-GRIP PVC may be used as a contact adhesive to apply VersiFleece TPO/PVC or bareback PVC membranes (not for use with bareback KEE HP) to vertical walls.
- 2. Application of CAV-GRIP PVC shall be applied continuously with 50 percent overlap on each pass.

E. Application of Bonding Adhesive

Use appropriate adhesive for the membrane selected. And when VersiFleece membrane is used for wall flashing refer to VersiFleece Specification for various adhesion methods.

- 1. Membrane shall be fully adhered to vertical surfaces with appropriate bonding adhesive. The Bonding Adhesive shall be applied continuously, without globs or puddles.
- 2. After the Bonding Adhesive has properly dried to a tack, roll the membrane into the adhesive and broom into place.
- 3. When VersiFleece Membrane is selected, the Bonding Adhesive must be applied to the membrane and allowed to flash off fully. Apply a layer of Bonding Adhesive to the vertical wall and second coat of Bonding Adhesive to the VersiFleece Membrane. After the Bonding Adhesive has properly dried, roll the membrane into the adhesive
- 4. Care must be taken when setting the flashing to avoid bridging greater than 3/4 inch at angle changes (i.e.,

where a parapet or roof penetration meets the roof deck). This can be accomplished by creasing the membrane into the angle change.

5. Terminate the edges of the installed membrane in accordance with Versico's applicable Termination Details.

F. Roof Drains

1. Provide a smooth transition from the roof surface to the drain clamping ring. Prepare the substrate around each roof drain to avoid membrane bridging in excess of 2" at the sump area and possible distortion at the drain clamping ring.
2. For drain sumps with slopes greater than 3" in 12":
 - a. When reinforced EPDM membrane is specified a separate piece of cured non-reinforced EPDM membrane must be extended into the drain sump as shown on the applicable detail.
 - b. When thermoplastic membrane has been specified, a separate piece of appropriate thermoplastic reinforced membrane must be extended into the drain sump as shown on the applicable detail.
3. The mating surfaces between the clamping ring and drain base must be clean and have a smooth finish. When using VersiFleece Membrane, remove fleece along the area of the membrane to be placed in the drain bowl and clamping ring.
4. Field splices at roof drains must be located at least 6" outside the drain sump.
5. Cut membrane so it extends approximately 1/2" beyond the attachment points of the clamping ring. The hole in the membrane must not restrict water flow or be smaller than the drain pipe.
6. Remove all existing flashing material to prepare for the membrane seal (application of Water Cut-Off Mastic).
7. All bolts and/or clamps must be in place to provide compression on the Water Cut-Off Mastic.
8. Use drain strainers, which have been approved by the specifier in accordance with applicable codes.

G. Metal Work

1. Versico recommends VersiTrim™ Metal Edging/Coping, Termination Bar or Drip Edge for membrane termination. Installation instruction sheets for Versico supplied accessories are available from Versico.

Note: Refer to Warranty Tables in applicable membrane system specification for metal edge requirements for projects with extended peak gust wind speed coverage greater than 80 miles per hour.
2. When specified, shop fabricated VersiTrim coated metal configured and installed as shown in Thermoplastic Edge Details will achieve ES-1 Compliance.
3. Metal work by others, when specified and approved by Versico, must be fastened to prevent metal from pulling free or buckling and sealed to prevent moisture from entering the roofing system or building. Unless supplied by Versico, metal work securement is not included in this specification and is excluded from the Versico Warranty. Refer to [Design Reference DR-12-18 "Metal Edging"](#) for applicable standards and [Spec Supplement G-10-18 "Metal Edging"](#) for recommended design parameters.
4. On retrofit projects, existing counterflashing, edging, expansion joint covers, copings, etc., shall not be reused unless investigated by the specifier to determine its compliance to Versico's current details.

H. EPDM Flashing Installation Criteria

1. **General**

- a. **Quick Applied Uncured EPDM Flashing** must be limited to the overlayment of vertical seams (as required at angle changes), or to flash inside/outside corners, vent pipes, scuppers and other unusually shaped penetrations where the use of Pre-molded Pipe Seals, cured EPDM membrane or Quick Applied Cured Cover Strip or Overlayment Strip is not practical.

Note: Even when working in warmer temperatures, in most cases a heat gun will be required to elevate the temperature of Quick Applied Uncured EPDM Flashing between 105°F and 110°F (40°C and 43°C) to permit proper forming of the uncured flashing.

- b. **Quick Applied Cured Cover Strip or Overlayment Strip** is used to overlay Seam Fastening Plates or metal edging flanges, etc., **Primer** must be used to clean the membrane and metal flanges.

2. Walls, Parapets, Curbs, Skylights, etc

- a. Continuous deck membrane for wall flashing.
 - 1) When using Quick Applied RTS (Reinforced Termination Strip) secure with proper seam fastening plates and fasteners at a rate of 12-inches on center at the base of the wall. Adhere flashing to Quick Applied RTS and the wall. Terminate the membrane in accordance with the applicable Termination Details.
 - 2) When securing the membrane at the base of the wall with proper seam fastening plates and fasteners through the continuous deck membrane, use minimum 6" wide Quick Applied Cured Cover Strip or Overlayment Strip to overlay fasteners and plates.
 - 3) When using VersiFleece membranes you must use a minimum of 9" of VersiFleece Membrane with fleece side up, at any location that requires membrane securement. VersiFleece Membrane must be fastened at a spacing not to exceed 12" O.C.
- b. When the use of continuous deck membrane for wall flashing is not feasible, a separate piece of cured EPDM membrane may be used.
 - 1) When **QA Seam Tape** is used, the **membrane and flashing** (Cured EPDM Flashing) must be cleaned with **Primer**.
- c. All vertical field splices at the base of a wall or curb must be overlaid with Quick Applied "T" Joint Covers or a 6" by 6" section (with rounded corners) of VersiGard Quick Applied Uncured EPDM Flashing centered over the field splice.

3. Other Penetrations

CAUTION: Projects with warranties greater than 20 years may require additional enhancement and double layer application of flashing. The Versico appropriate flashing detail should be referenced for specific requirements.

- a. Flash pipes and round supports with Molded Pipe Seals or Quick Applied Pipe Seals, when feasible, in accordance with the applicable detail.
- b. Form Field Fabricated Pipe Seals using Quick Applied Uncured EPDM Flashing around pipes, round supports and structural steel tubing with corner radius greater than 1/4".
- c. When flashing seamless metal posts, maximum 4" by 4", with a corner radius less than 1/4", apply a field fabricated pipe flashing with a double vertical wrapping.
- d. For pipe clusters or unusually shaped penetrations, a pourable sealer pocket must be utilized.

I. Thermoplastic Flashing Installation Criteria

1. General

- a. Where feasible, Pre-Molded Accessories should be used for corners, pipes, curbs, and sealant pockets. Pre-Fabricated Pourable Sealer Pockets for sealant pockets and Pre-Fabricated Curb Wrap Corners for Curb Corners. Projects with 20 years or greater warranties require the use of pre-molded and/or pre-fabricated accessories unless prohibited by a specific field condition. Refer to [Spec Supplement P-01-22 Related Versico Products](#).
- b. When the use of Pre-Molded Accessories is not feasible, Non-reinforced thermoplastic membrane can be used for flashing pipe penetrations, sealant pockets and scuppers as well as inside/outside corners.
- c. Care must be taken when setting the flashing to avoid bridging greater than 3/4 inch at angle changes (i.e., where a parapet or roof penetration meets the roof deck). This can be accomplished by creasing the membrane into the angle change.
- d. For Thermoplastic membranes, when possible, all reinforced membrane splices are heat welded with the Automatic Heat Welder. The Hand Held Hot Air Welder should be utilized in hard to reach areas, smaller curbs, vertical splices and when using non-reinforced membrane.
- e. Cut edges of TPO membrane, where scrim reinforcement is exposed, must be sealed with Cut-Edge Sealant (not required on vertical surfaces). Cut edges of PVC membrane are not required to be sealed with Cut-Edge Sealant, however, it is recommended.
- f. When flashing walls with PVC membrane, bitumen based roof cement must be removed or concealed with an acceptable underlayment. Bitumen based roof cement and asphaltic-based flashing material, if allowed to remain in contact with a PVC membrane, will cause severe membrane discoloration and promote plasticizer migration.

CAUTION: Some discoloration of the TPO Membrane may be experienced due to contact with residual asphalt which may have been left in place.

2. Walls, Parapets, Curbs, Skylights, etc.

- a. For Thermoplastic membranes, flashing of parapets, curbs, expansion joints and other parts of the roof must be the appropriate thermoplastic reinforced membrane.
- b. For Thermoplastic membranes, the flashing height must be calculated so that the membrane flashing includes a minimum 1-1/2 inch heat weld beyond the Fastening Plates.
- c. Fasten at angle change as with the required Versico Fastener and plate.
- d. Flash the fasteners/plates with a separate piece of thermoplastic reinforced membrane; apply heat and crease the flashing into the angle change before attaching it to the vertical surface.

Copyright 2024 Versico

Versico, VersiFleece, Flexible DASH and VersiTrim are Trademarks of Versico

This Spec Supplement represents the applicable information available at the time of its publication. Owners, Specifiers and Versico authorized roofing contractors should consult Versico or their Versico Independent Representative for any information that has subsequently been made available.

Review the appropriate Versico Warranty for specific warranty coverage, terms, conditions and limitations.



SPECIFICATION

SUPPLEMENT

G-05-21

Roof Walkway Installation

January 2024

The information contained in this supplement serves as a criteria for Specifiers and Authorized Contractors regarding the design and installation of Versico Roofing Systems and related products. Additional information essential for the design and installation of the Roof Systems mentioned herein are also included in the respective Specification for each Roof System and in the Design Reference Section of the Versico Technical Manual. Specifiers and Authorized Contractors are advised to reference all applicable sections.

A. Roof Walkways

Walkways are to be specified at all traffic concentration points (i.e., roof hatches, access doors, rooftop ladders, etc.), and if regular maintenance (once a month or more) is necessary to service rooftop equipment.

1. Walkway types:

- a. **Versico Quick Applied Molded Walkway Pads:** Versico (black or white) molded walkway pads with Factory-Applied QA Seam Tape are used to provide protection for areas of EPDM membrane that are exposed to regular rooftop maintenance.

CAUTION: Molded Walkway pads not recommended within 10 feet of the perimeter of the roof on ballasted systems to avoid discontinuation of the primary membrane securement (ballast). In lieu of molded walkway pads, concrete pavers can be used when walkway is to be extended into the perimeter area.

- b. **VersiWeld® TPO Heat Weldable Walkway Rolls** are required when walkway pads are to be specified. The Walkway Rolls are heat welded to the VersiWeld membrane using an Automated Heat Welder or Hand-Held Heat Welder. Walkway Rolls are 34 inches wide by 50 feet long and are nominal 170 mils thick. Available in white, gray or tan with safety yellow welding tabs along each edge.
- c. **VersiFlex™ PVC Heat Weldable Walkway Rolls** are required when walkway pads are to be specified. The Walkway Rolls are heat welded to the VersiFlex (PVC/KEE HP) membrane using an Automated Heat Welder or Hand-Held Heat Welder. Walkway Rolls are 36 inches wide by 60 feet long and are nominal 110 mils thick. Available in gray only.
- d. **VersiWeld TPO Crossgrip Walkway Rolls** may be used in lieu of standard VersiWeld TPO Walkway Rolls when a walkway is to be loose-laid and not secured to the membrane. Loose-laid Crossgrip TPO Walkway Rolls are effective for winds up to 55 mph. Rolls are 36" wide by 33' long, available in white, gray and yellow.
- e. **VersiFlex PVC Crossgrip Walkway Rolls:** Manufactured from PVC and may be used in lieu of standard VersiFlex PVC Walkway Rolls when a walkway is to be loose-laid and not secured to the membrane. Loose-laid Crossgrip PVC Walkway Rolls are effective for winds up to 55 mph. Rolls are 36" wide by 33' long, available in white, gray and yellow.
- f. **Versico Interlocking Pavers**, 24" X 24" X 2", weighing approximately 6 pounds per square foot, may be specified loose laid directly over the membrane. Installation Instruction sheets are available from Versico.

- g. **Smooth concrete pavers**, when specified in conjunction with insulation that is mechanically attached, must be loose laid over a slip sheet of membrane or 2 layers of HP Protective Mat. When insulation is attached with Flexible DASH Adhesive, concrete pavers may be placed over one layer of HP Protective Mat. Pavers cannot weigh more than 100 pounds per paver for ease of removal. For other Applicable Versico Products refer to Technical Data Bulletins for information.
- h. **Hanover Prest Plaza Paver** – A pre-cast concrete paver used in conjunction with roof garden applications or for ballasted roof applications. 23-1/2" x 23-1/2" x 2" thick precast concrete pavers weighing 25 psf. Available in a sandstone finish for aesthetic projects and non-slip diamond or stippled finish for ballasted roof projects. Prest pavers are available in 8 standard colors, with special order colors available. The Prest paver can either be installed in conjunction with a separation layer of HP Protective Mat or using Hanover EPDM Pedestals, High-Tab Pedestals, or Elevated Pedestals
- i. **Hanover Guardian Paver** – A pedestal paver system designed to meet severe site conditions and high winds, the guardian paver system utilizes a unique three-piece pedestal system and shaped paver which incorporates a top and bottom plate with a bolt connecting the entire paver system together which creates a monolithic surface and provides increased wind performance. The pavers are 23-1/2" x 23-1/2" x 2" or 3" thick. 2" pavers weigh 25 psf and 3" pavers weigh 38 psf. Available in a sandstone finish for aesthetic projects and non-slip diamond or stippled finish for ballasted roof projects. Guardian pavers are available in 8 standard colors, with special order colors available. The Guardian paver can either be installed in conjunction with a separation layer of HP Protective Mat or using Hanover Elevated Pedestals.
- j. **Hanover Pedestal Paver** - Used for light traffic areas associated with rooftop or garden roof applications. 23-1/2" x 23-1/2" x 2-1/4" thick precast concrete pavers weighing 22 psf with an elevated clearance of 1/2" from incorporated footing. Available in 8 standard colors, with special order colors available. The pedestal paver can either be installed in conjunction with a separation layer of HP Protective Mat, no pedestals are required
- k. **Hanover Ballast and Lightweight Ballast Paver** – The standard, 24" x 24" x 1-13/16" thick, Ballast Paver comes in a natural color and a non-slip Diamond finish and weighs 22 lbs/sq. ft. The Lightweight, 23-1/2" x 23-1/2" x 1-1/4" thick, Ballast Paver comes in a natural color and a non-slip diamond finish and weighs 15 lbs/sq. ft. Both pavers can be used as ballast or walkways.
- l. **Sunny Brook Paver** – A pre-cast concrete paver used in conjunction with roof garden applications or for ballasted roof applications. 23-1/2" x 23-1/2" x 2" thick precast concrete pavers weighing 24 psf. Available in 17 standard colors, with special order colors available. The pedestal paver can either be installed in conjunction with a separation layer of HP Protective Mat or using MRP Pedestal and shims.
- m. **MRP Pedestals** - Designed to support concrete pavers, a pedestal system with a self-leveling head and adjustment key which can modify the height of the pedestal from the top with a special tool. 100% recyclable and a loading capacity of each support is more than 2,205 lbs and the supporting base is 49.6 sq. in.

- 2. Pavers are not recommended for use as walkways on projects where the roof slope exceeds 2 inches per horizontal foot.
- 3. Walkways are considered a maintenance item and are excluded from the Versico warranty.
- 4. Window washing equipment will require special maintenance. Runways or window washing tracks must be utilized to prevent damage to membrane or insulation. Such details must be reviewed by Versico to determine reasonable access to the membrane and associated insulation/underlayment components.

NOTE: Pavers are not recommended for use as walkways where slippery conditions may be encountered. Paver slippage may occur due to the lower membrane surface temperature and the presence of frost or ice.

B. Walkway Installation

- 1. Install walkways in those locations as designated by the specifier.

2. VersiGard Quick Applied Molded Walkway Pads
 - a. Use Weathered Membrane Cleaner to remove dirt or other contaminants from the area.
 - b. Adhere Walkway Pads using Versico EPDM Primer. Apply primer to deck surface where tape will contact deck surface.
 - c. Allow a 1" wide break between Walkway Pads. Discontinue Walkways over field splices allowing a minimum 1" space.
3. VersiWeld/VersiFlex Heat Weldable Walkway Rolls
 - a. Use Weathered Membrane Cleaner (TPO) or PVC and KEE HP Membrane Cleaner (PVC) to remove dirt or other contaminants from the area to be welded to the walkway material.
 - b. Position the walkway material and cut the Walkway Rolls into maximum 10' lengths (when positioned parallel to field splices) and position with a minimum 1" gap between adjacent pieces to allow for water drainage. When walkways are to be installed perpendicular to field splices, adjust walkway length to provide a 4" - 6" minimum gap at field splices. (Because the attachment of the walkway to the membrane is permanent, this will allow access to the field seams).
 - c. Using an Automatic Heat Welder, weld all 4 sides of the walkway material to the membrane. (Typically the same speed and temperature settings will be used for this procedure as for welding membrane to membrane. A test weld is always recommended prior to performing welds to the installed membrane). A hand held welder may be utilized however, productivity will be decreased.

If, possible, allow the walkway to warm by the sun prior to welding so distortion will not occur due to expansion.
4. VersiWeld TPO or VersiFlex PVC Crossgrip Walkway Rolls
 - a. Loose-lay Crossgrip in areas of high traffic or around mechanical units that might require servicing.
5. Concrete Paver Blocks
 - a. Install a slip-sheet of roofing membrane under all concrete pavers for the protection of the deck membrane. The protective layer must extend a minimum of 2" on each side of the walkway.
6. Versico Interlocking Rubber Pavers
 - a. Rubber Pavers can be loose laid directly over the membrane.

NOTE: Pavers are not recommended for walkways when slopes exceed 2" per horizontal foot. Slippage could be encountered during colder seasons.

Copyright 2024 Versico

Versico, VersiGard, VersiWeld and VersiFlex are Trademarks of Versico

This Design Reference represents the applicable information available at the time of its publication. Owners, specifiers and Versico authorized roofing Contractors should consult Versico or their Versico Independent Sales Representative for any information that has subsequently been made available.

Review the appropriate Versico Warranty for specific warranty coverage, terms, conditions and limitations.



SPECIFICATION

SUPPLEMENT

G-06-20

Daily Seal & Clean Up

January 2024

The information contained in this supplement serves as a criteria for Specifiers and Authorized Contractors regarding the design and installation of Versico Roofing Systems and related products. Additional information essential for the design and installation of the Roof Systems mentioned herein are also included in the respective Specification for each Roof System and in the Design Reference Section of the Versico Technical Manual. Specifiers and Authorized Contractors are advised to reference all applicable sections.

A. Daily Seal

1. On phased roofing, when the completion of flashings and terminations is not possible by the end of each workday, provisions must be taken to temporarily close the membrane to prevent water infiltration.
2. Temporarily seal any loose membrane edge down slope using VersiGard Two Part Pourable Sealer (EPDM only), Flexible DASH Adhesive, VapAir Seal Flashing Foam, hot asphalt, or a similar product so that the membrane edge will not buck water. Caution must be exercised to ensure positive draining during installation, temporary seal locations should be designated so that drainage is not restricted during construction by partially installed roof sections.
 - a. When applying Flexible DASH Adhesive or other sprayed urethane foam, prime the surface of the membrane with Versico Primer to ensure proper adhesion
 - b. Versico Pourable Sealer, when utilized, shall be applied as follows:
 - 1) The two Pourable Sealer components must be mixed in accordance with the instructions on the container labels.
 - 2) Apply the Pourable Sealer along the loose edge of the EPDM membrane. If necessary, use a trowel to spread Pourable Sealer to achieve complete coverage.
3. When tie-in to existing built-up roofs, remove the gravel. The surface must be clean and dry.
4. After embedding membrane in daily seal material, CHECK FOR CONTINUOUS CONTACT. Provide continuous pressure over the length of the temporary seal with 15' lengths of 2-1/2" diameter Versico Lay Flat Tubing filled with dry sand. Provide weight evenly distributed along the length of the daily seal to reduce the wind effect on the continuous temporary seal.

Note: The use of rigid wood nailers is not recommended due to warping. Constant compression cannot be achieved on an uneven substrate.
5. When work is resumed, pull the imbedded membrane free; trim and remove daily seal material from membrane before continuing installation of adjoining sections.

B. Clean Up

1. If required by the specifier to ensure the aesthetics of the surface of the membrane, hand prints, footprints, general traffic grime, industrial pollutants and environmental dirt may be cleaned from the surface of the membrane by scrubbing with soapy (non-abrasive soap) water and rinsing the area completely with clean water.
 - a. For VersiGard (black or white) or VersiWeld membrane, Weathered Membrane Cleaner can be used to clean the surface of the membrane.
 - b. For VersiFlex Membrane, PVC Membrane Cleaner can be used to clean the surface of the membrane.
2. Bonding Adhesive and Flexible DASH Adhesive and VapAir Flashing Foam residue may be cleaned by using the following procedures:
 - a. Saturate a clean HP Splice Wipe with Weathered Membrane Cleaner (EPDM and TPO) or PVC and KEE HP Membrane Cleaner (PVC).
 - b. Scrub exposed adhesive with the saturated HP Splice Wipe until all residue is removed from the membrane. For easier removal, it may be necessary to change Splice Wipes frequently.

Copyright 2024 Versico

Versico, VersiGard, VersiWeld, VersiFlex and VersiFleece are Trademarks
of Versico

This Spec Supplement represents the applicable information available at the time of its publication. Owners, Specifiers and Versico authorized roofing contractors should consult Versico or their Versico Independent Sales Representative for any information that has subsequently been made available.

Review the appropriate Versico Warranty for specific warranty coverage, terms, conditions and limitations.



SPECIFICATION

SUPPLEMENT

G-07-20

Application Procedures for Versico VapAir Seal 725TR Air and Vapor Barrier

January 2024

The information contained in this supplement serves as a criteria for Specifiers and Authorized Contractors regarding the design and installation of Versico Roofing Systems and related products. Additional information essential for the design and installation of the Roof Systems mentioned herein are also included in the respective Specification for each Roof System and in the Design Reference Section of the Versico Technical Manual. Specifiers and Authorized Contractors are advised to reference all applicable sections.

A. General

1. **Versico's VapAir Seal 725TR Air and Vapor Barrier** A 40-mil thick composite consisting of 35-mil self-adhering rubberized asphalt membrane laminated to an 5-mil UV resistant poly film with an anti-skid surface which is fully compatible with Flexible DASH Adhesive. VapAir Seal 725TR can also function as a temporary roof for up to 120 days. Available in rolls 39" wide by 100' long (325 square feet).
2. **CAV-GRIP 3V Low-VOC Adhesive/Primer:** a low-VOC, methylene chloride-free adhesive that can be used for a variety of applications including: enhancing the bond between Versico's VapAir Seal 725TR and various substrates. Coverage rate is approximately 2,000-2,500 sq. ft. per 40 lb cylinder and 4,000-5,000 sq. ft. per 85 lb cylinder as a primer, in a single-sided application.
3. **CCW-702 Primer and 702LV Primer (Low-VOC)** - A single component, solvent based, high-tack primer used to provide maximum adhesion between Versico 725TR Air and Vapor Barrier and an approved substrate. Applied by spray or long nap roller with a coverage rating ranging from approximately 300 to 350 square feet per gallon on smooth finishes (i.e., concrete) to 75 square feet per gallon on porous surfaces (i.e., Dens-Deck Prime gypsum board). Available in 5-gallon containers. CCW 702LV Primer contains less than 250g/L VOCs and meets South Coast Air Quality Management District (SCAQMD) and Leadership in Energy and Environmental Design (LEED) Requirements for Volatile Organic Compounds.
4. **CCW-702WB** – a high-tack, water-based contact adhesive for promoting adhesion of Versico air/vapor barrier membranes and an approved substrate (i.e., concrete, Dens-Deck Prime and Securock). Applied by roller, brush or spray with an application rate of approximately 200 sq. ft. per gallon. Available in 5-gallon containers. CCW-702WB Primer contains 57g/L VOCs and meets South Coast Air Quality Management District (SCAQMD) and Leadership in Energy and Environmental Design (LEED) Requirements for Volatile Organic Compounds.

B. Approved Substrates

Versico VapAir Seal 725TR Air and Vapor Barrier, in conjunction with either Versico's CAV-GRIP 3V, CCW-702, CCW-702LV or CCW-702WB Primers, can be used over structural concrete, gypsum and wood decks. In addition, Securock/DensDeck Prime (typically used over steel deck construction) is a suitable substrate providing it is mechanically attached to the deck at the minimum rate of 1 per 2 per square foot or adhered to the deck with Flexible DASH Adhesive per Versico Specifications.

CAUTION: Use of standard DensDeck is not recommended due to excessive primer absorption. When the use of standard DensDeck is specified, two coats of CCW Primer will be required along with a trial test to verify adequate adhesion of the Versico VapAir Seal 725TR Air and Vapor Barrier.

C. Limitations

1. Do not apply primer or vapor barrier to frozen substrates. Best results are obtained when temperature is above 40°F (4°C).
2. Do not apply primer or vapor barrier to damp or contaminated surfaces.
3. Versico VapAir Seal 725TR Air and Vapor Barrier is not recommended for use over sealants containing coal tar or polysulfides. If these materials are present, they must be removed and the surfaces thoroughly cleaned.

D. Installation

1. **Surface Preparation:** The surface shall be dry, have a smooth finish and be free of voids, spalled areas, sharp protrusions, loose aggregate, laitance and form release agents. In the event of rain, concrete must be allowed to dry before primer is applied.
2. **Primer:** Surfaces to receive Versico's VapAir Seal 725TR Air and Vapor Barrier must be clean and dry. Prime with Versico's CAV-GRIP 3V, CCW-702, CCW-702LV or CCW-702WB Primer. Apply Primer by spray, brush or with a long nap roller at the applicable coverage rate noted above. At 75° F allow CCW-702 or 702LV primer to dry 75 minutes minimum or allow CAV-GRIP 3V to dry for approximately 5 minutes. Primer has a satisfactory cure when it will not transfer when touched. Prime only areas to be waterproofed the same day. Re-prime if area becomes dirty.
3. **Application:** Apply Versico VapAir Seal 725TR Air and Vapor Barrier from low to high point, in a shingle fashion, so that laps will shed water. Overlap all edges at least 2". End laps shall be staggered. Seams and end laps must be rolled with a 2" seam roller. Place membrane carefully to avoid wrinkles and fishmouths. Immediately after installation, roll with a 30" wide, 150 pound weighted segmented steel roller.
4. **Repairs:** Following application, inspect VapAir Seal 725TR membrane for tears, punctures, fishmouths, air bubbles and voids due to misalignment at seams. Remove damaged membrane. Prime exposed substrate and allow primer to dry. Apply a new section of Versico VapAir Seal 725TR Air and Vapor Barrier to primed substrate, extending onto adhered membrane 6" on all sides. Firmly press air and vapor barrier repair section to ensure a good seal. Slit fishmouths and overlap the edges. Place a section of Versico's VapAir Seal 725TR over the repair and extend 6" in all directions. Firmly press repair section to ensure a good seal.
5. **Insulation and VersiFleece Membrane Installation:** Ensure surface of Versico's VapAir Seal 725TR Air and Vapor Barrier is dry prior to installing insulation. Place insulation over the surface and mechanically attach to the roof deck or adhere to the vapor barrier with Flexible DASH Adhesive in accordance with this Versico Specification. Complete the installation by adhering VersiFleece membrane over the insulation.
6. **Installation at angle changes:** For VersiFleece Systems where insulation is adhered to the vapor retarder and adhered roofing systems with vertical base wall securement and adhered insulation, one of the following options must be incorporated to ensure continuous seal is provided during climatic changes, especially in northern regions:
 - a. Option One: Mechanically secure the first course of insulation (bottom layer) with insulation fasteners and plates. A row of fasteners shall be installed within 6" of the angle change spaced 12" O.C.
 - b. Option Two: In lieu of fastening, install a 3" diameter backer rod along the angle change to accommodate for movement and prevent the effect of the vapor retarder pulling away from angle change.

Note: Maintain mylar backing at the sponge tubing to prevent the VapAir Seal 725TR from adhering to the tubing. As shown in the applicable Versico Detail.
 - c. Option Three: In lieu of fastening and when the use of backer rod is not possible, the VapAir Seal 725TR can be installed with a double fold, allowing extra material to accommodate for structural movement.

Note: Maintain mylar backing within the fold to allow for material expansion in the event of movement. Refer to applicable Versico Detail.

Copyright 2024 Versico

Versico and VersiFleece are Trademarks of Versico

Dens Deck is a Trademark of Georgia-Pacific Gypsum LLC

Securock is a Trademark of USG Corporation

This Spec Supplement represents the applicable information available at the time of its publication. Owners, Specifiers and Versico authorized roofing Contractors should consult Versico or their Versico Independent Sales Representative for any information that has subsequently been made available.

Review the appropriate Versico Warranty for specific warranty coverage, terms, conditions and limitations.



SPECIFICATION

SUPPLEMENT

G-08-23

Insulation Attachment and Details

January 2024

The information contained in this supplement serves as a criteria for Specifiers and Authorized Contractors regarding the design and installation of Versico Roofing Systems and related products. Additional information essential for the design and installation of the Roof Systems mentioned herein are also included in the respective Specification for each Roof System and in the Design Reference Section of the Versico Technical Manual. Specifiers and Authorized Contractors are advised to reference all applicable sections.

TABLE OF CONTENTS

Adhered Systems	Detail
Insulation / Cover Board Attachment.....	A-27.1
Minimum 2" Thick Versico MP-H/ Securshield Polyisocyanurate Insulation.....	A-27.2
Minimum 1-1/2" Thick Versico MP-H / Securshield Polyisocyanurate Insulation	A-27.3
1/4" Or 1/2" Thick Securock Or DensDeck/DensDeck Prime.....	A-27.4
5/8" Thick Securock, DensDeck/DensDeck Prime or DenDeck StormX Prime	A-27.5
Versico Durafacer (OSB/Polyisocyanurate Composite).....	A-27.6
Insulation / Cover Board Attachment Using Bead Adhesive	A-27.7
Mechanically Attached Systems	Detail
Insulation / Cover Board Attachment For ALL Warranty Durations	MA-27
R-Tech Fanfold Roof Underlayment.....	MA-27.3
R-Tech Fanfold Roof Underlayment For FM Assemblies.....	MA-27.4
Insulation/Cover Board Attachment When Using SecurShield Family Products For All Warranties Lengths	MA-27.5

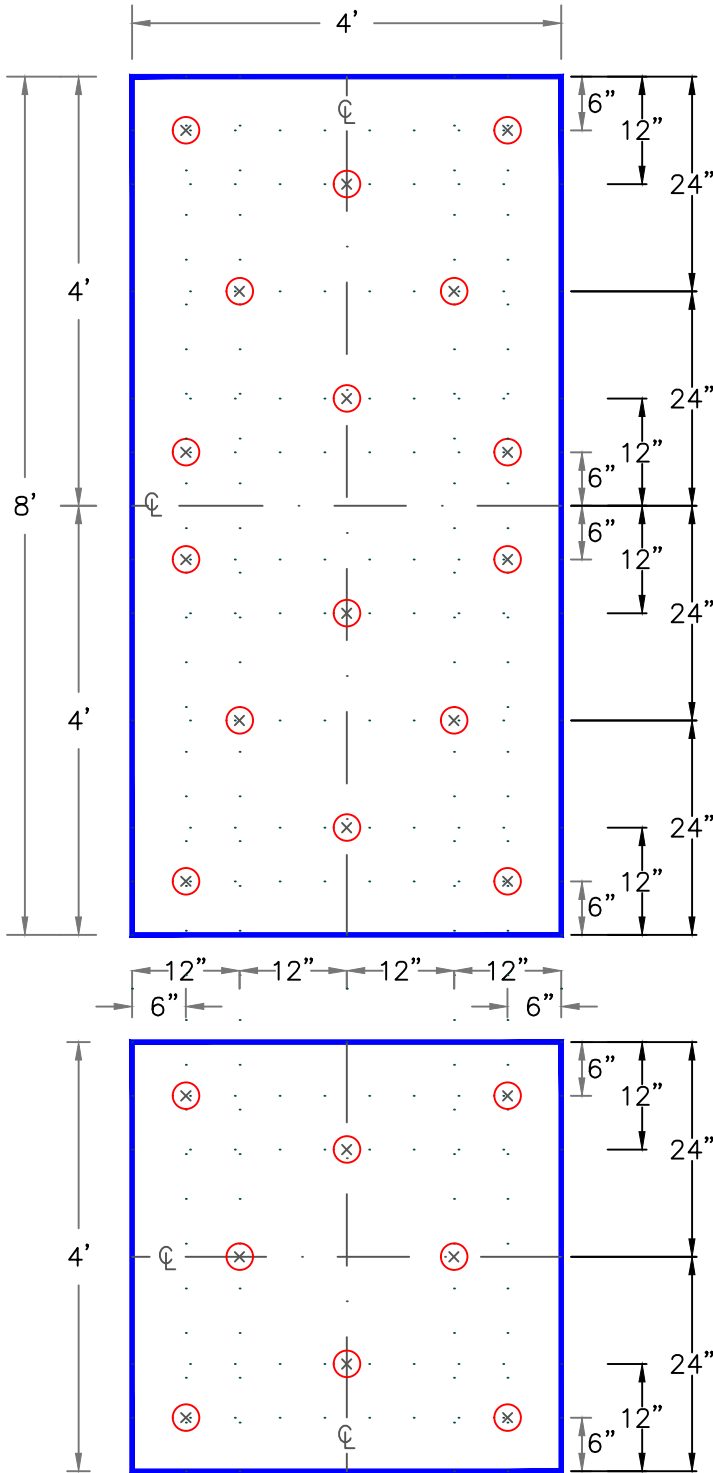

NOTES:

1. WHEN ENHANCED INSULATION FASTENING IS REQUIRED AS PRESCRIBED IN FACTORY MUTUAL LOSS PREVENTION DATA SHEET 1-29, ANSI/SPRI WD-1, OR MIAMI-DADE COUNTY, REFER TO [VERSICO'S DESIGN REFERENCE DR-05-18.](#)
2. FOR CRITERIA ON INSULATION FASTENERS AND PLATES, REFER TO VERSICO SPECIFICATIONS.
3. IF A WIND SPEED WARRANTY GREATER THAN 55 MPH (25 METERS PER SECOND) OR A WARRANTY TERM GREATER THAN 20-YEARS IS SPECIFIED, ADDITIONAL FASTENING MAY BE REQUIRED, REFER TO VERSICO SPECIFICATIONS.

FEET TO CENTIMETERS	
4'	8'
122	244

INCHES TO CENTIMETERS																	
inch	1/4"	1/2"	3/4"	1"	1.5"	2"	2.5"	3"	4"	5"	6"	7"	8"	9"	10"	11"	12"
cm	1	1.5	2	2.5	4	5	6.5	7.5	10	13	15	18	20	23	25	28	30



VERSICO INSULATION / COVERBOARD ATTACHMENT

→ FASTENER & PLATE
 → CENTER LINE
 → GUIDE LINE

ADHERED SYSTEM

A-27.1

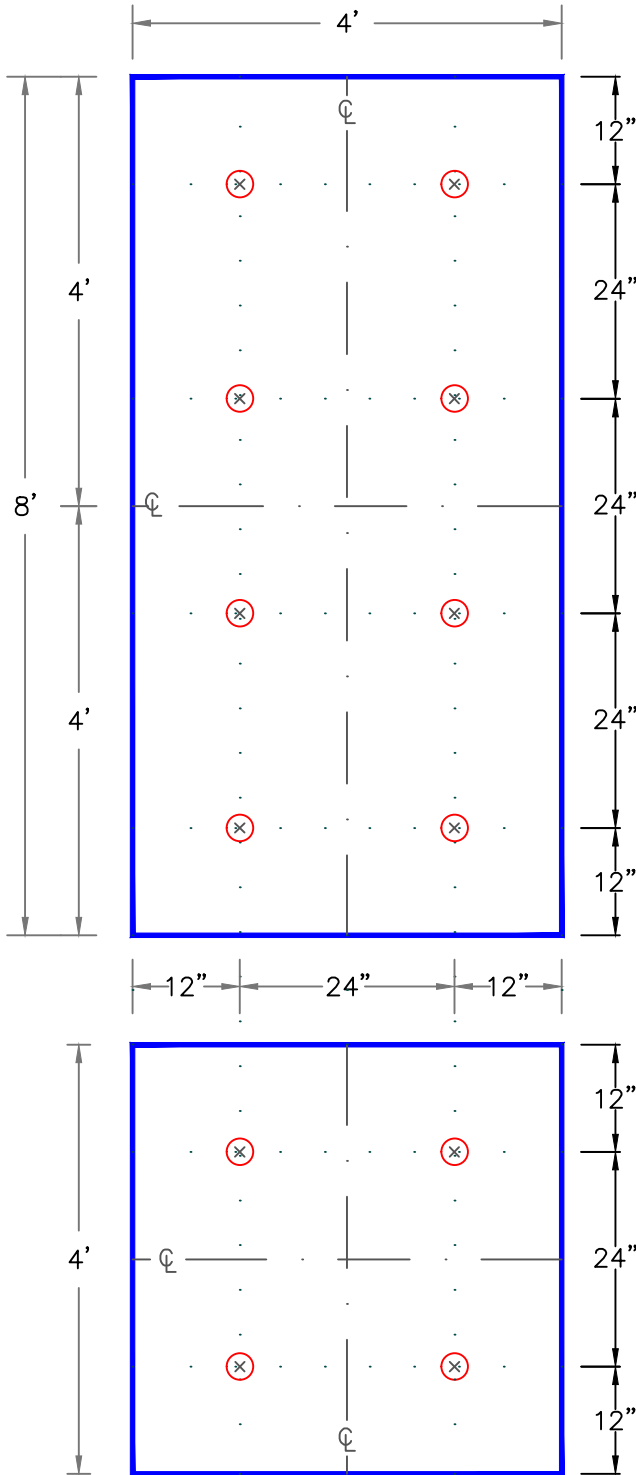

NOTES:

1. THIS DETAIL APPLIES TO MIN. 2" (51mm) THICK (SINGLE OR TOP LAYER) VERSICO POLYISOCYANURATE INSULATION WHEN FASTENED INTO 22-GAUGE STEEL, STRUCTURAL CONCRETE, MINIMUM 15/32" (12mm) PLYWOOD OR 1-1/2" (38mm) THICK WOOD PLANK ROOF DECKS.
2. WHEN ENHANCED INSULATION FASTENING IS REQUIRED AS PRESCRIBED IN FACTORY MUTUAL LOSS PREVENTION DATA SHEET 1-29, ANSI/SPRI WD-1 OR MIAMI-DADE COUNTY, REFER TO [VERSICO'S DESIGN REFERENCE DR-05-18.](#)
3. FOR CRITERIA ON INSULATION FASTENERS AND PLATES, REFER TO VERSICO SPECIFICATIONS.
4. IF A WIND SPEED WARRANTY GREATER THAN 55 MILES PER HOUR (25 METERS PER SECOND) OR A WARRANTY TERM GREATER THAN 20-YEARS IS SPECIFIED OR FOR SYSTEMS OVER 50'(15METERS), ADDITIONAL FASTENING MAY BE REQUIRED, REFER TO VERSICO SPECIFICATIONS.
5. DETAIL NOT FOR USE OVER ORIENTED STRAND BOARD, GYPSUM, FIBROUS CEMENT (TECTUM), LIGHTWEIGHT INSULATING CONCRETE OR STEEL ROOF DECK THINNER THAN 22-GAUGE (0.8mm), [REFER TO DETAIL A-27.1](#) FOR ACCEPTABLE FASTENING.

FEET TO CENTIMETERS	
4'	8'
122	244

INCHES TO CENTIMETERS																	
inch	1/4"	1/2"	3/4"	1"	1.5"	2"	2.5"	3"	4"	5"	6"	7"	8"	9"	10"	11"	12"
cm	1	1.5	2	2.5	4	5	6.5	7.5	10	13	15	18	20	23	25	28	30



MINIMUM 2" THICK VERSICO MP-H/VERSICORE/SECURSHIELD POLYISOCYANURATE INSULATION

→ FASTENER & PLATE
 → CENTER LINE
 → GUIDE LINE

ADHERED SYSTEM

A - 27.2

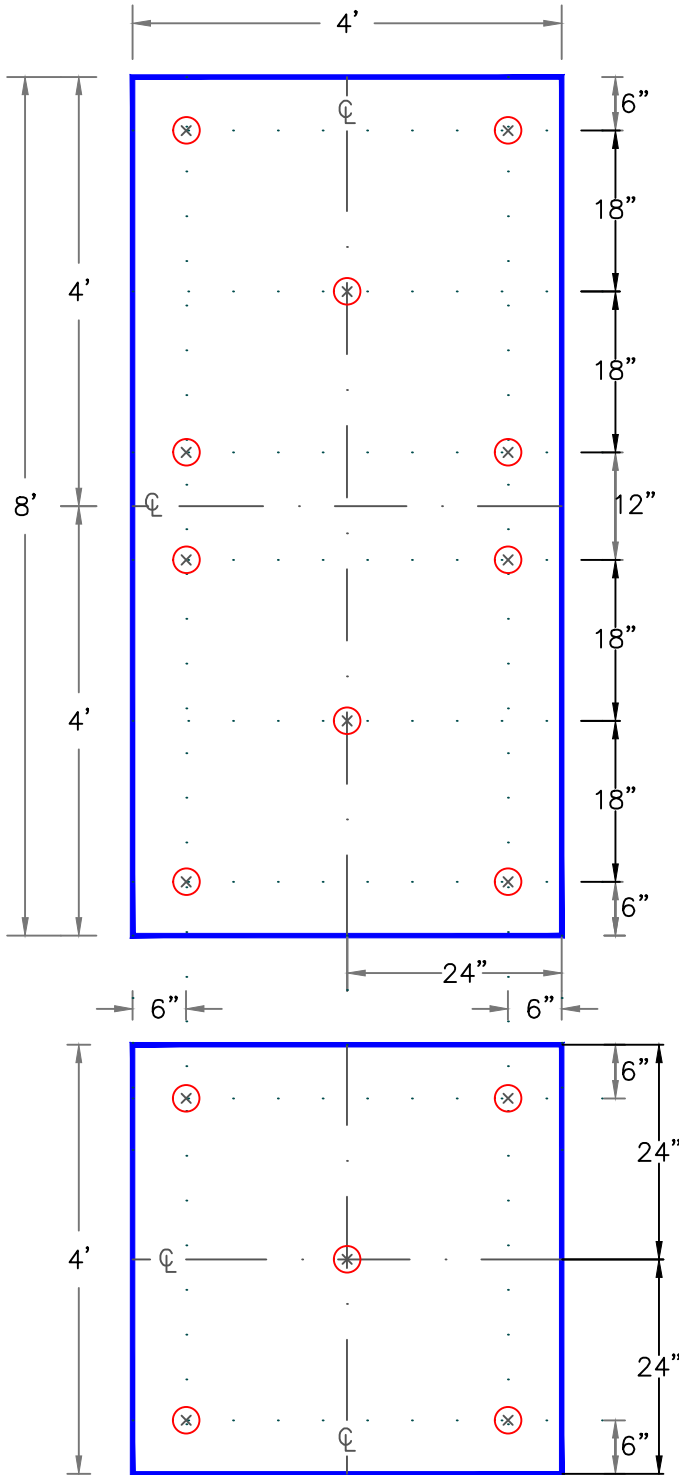

NOTES:

1. THIS DETAIL APPLIES TO MIN. 1-1/2" (38mm) THICK (SINGLE OR TOP LAYER) VERSICO POLYISOCYANURATE INSULATION WHEN FASTENED INTO 22-GAUGE STEEL, STRUCTURAL CONCRETE, MINIMUM 15/32" (12mm) PLYWOOD OR 1-1/2" (38mm) THICK WOOD PLANK ROOF DECKS.
2. WHEN ENHANCED INSULATION FASTENING IS REQUIRED AS PRESCRIBED IN FACTORY MUTUAL LOSS PREVENTION DATA SHEET 1-29, ANSI/SPRI WD-1 OR MIAMI-DADE COUNTY, REFER TO [VERSICO'S DESIGN REFERENCE DR-05-18.](#)
3. FOR CRITERIA ON INSULATION FASTENERS AND PLATES, REFER TO VERSICO SPECIFICATIONS.
4. IF A WIND SPEED WARRANTY GREATER THAN 55 MILES PER HOUR (25 METERS PER SECOND) OR A WARRANTY TERM GREATER THAN 20-YEARS IS SPECIFIED OR FOR SYSTEMS OVER 50'(15METERS), ADDITIONAL FASTENING MAY BE REQUIRED, REFER TO VERSICO SPECIFICATIONS.
5. THIS DETAIL NOT FOR USE OVER ORIENTED STRAND BOARD, GYPSUM, FIBROUS CEMENT (TECTUM), LIGHTWEIGHT INSULATING CONCRETE OR STEEL ROOF DECK THINNER THAN 22-GAUGE (0.8mm), [REFER TO DETAIL A-27.1](#) FOR ACCEPTABLE FASTENING.

FEET TO CENTIMETERS	
4'	8'
122	244

INCHES TO CENTIMETERS																	
inch	1/4"	1/2"	3/4"	1"	1.5"	2"	2.5"	3"	4"	5"	6"	7"	8"	9"	10"	11"	12"
cm	1	1.5	2	2.5	4	5	6.5	7.5	10	13	15	18	20	23	25	28	30



MINIMUM 1-1/2" THICK
VERSICO
MP-H/VERSICORE/SECURSHIELD
POLYISOCYANURATE
INSULATION

→ FASTENER & PLATE
 → CENTER LINE
 → GUIDE LINE

ADHERED SYSTEM

A - 27.3

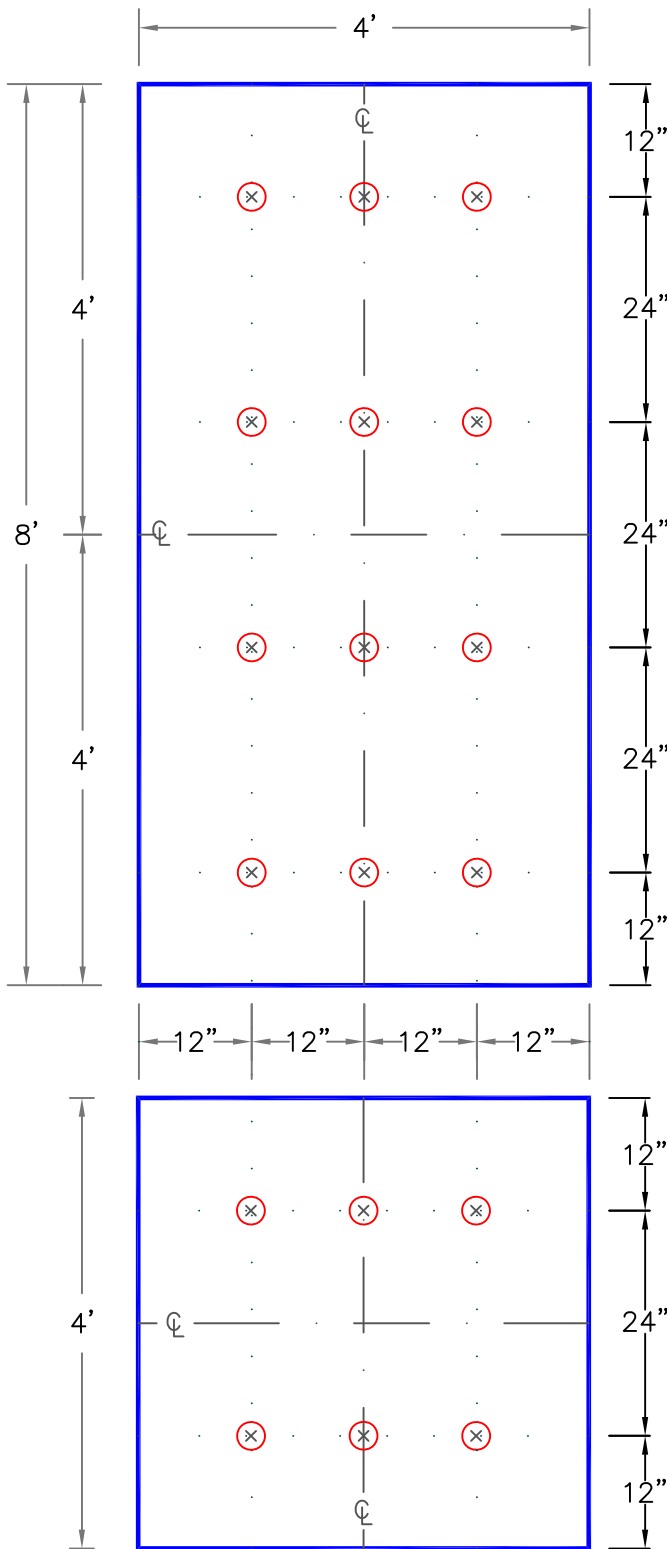

NOTES:

1. THIS DETAIL APPLIES TO 1/4" (6.4mm) AND 1/2" (13mm) THICK SECUROCK OR DENS DECK PRIME (OVER AN APPROVED INSULATION) WHEN FASTENED INTO 22-GAUGE (0.8mm) STEEL, STRUCTURAL CONCRETE, MINIMUM 15/32" (12mm) PLYWOOD OR 1-1/2" THICK WOOD PLANK ROOF DECKS.
2. WHEN ENHANCED FASTENING IS REQUIRED AS PRESCRIBED IN FACTORY MUTUAL LOSS PREVENTION DATA SHEET 1-29, ANSI/SPRI WD-1 OR MIAMI-DADE COUNTY, REFER TO [VERSICO'S DESIGN REFERENCE DR-05-18.](#)
3. FOR CRITERIA ON INSULATION FASTENERS AND PLATES, REFER TO VERSICO SPECIFICATIONS.
4. IF A WIND SPEED WARRANTY GREATER THAN 55 MILES PER HOUR (25 METERS PER SECOND) OR A WARRANTY TERM GREATER THAN 20-YEARS IS SPECIFIED OR FOR SYSTEMS OVER 50'(15METERS), ADDITIONAL FASTENING MAY BE REQUIRED, REFER TO VERSICO SPECIFICATIONS.
5. DETAIL NOT FOR USE OVER ORIENTED STRAND BOARD, GYPSUM, FIBROUS CEMENT (TECTUM), LIGHTWEIGHT INSULATING CONCRETE OR STEEL ROOF DECK LESS THAN 22-GAUGE (0.8mm), [REFER TO DETAIL A-27.1](#) FOR ACCEPTABLE FASTENING.
6. WHEN INSTALLED OVER COMBUSTIBLE WOOD DECKS OR INSULATIONS, ALL JOINTS SHALL BE STAGGERED.
7. LONG UNINTERRUPTED RUNS >200' (>61M) OF SECUROCK MAY REQUIRE SLIGHT GAPPING DUE TO THERMAL EXPANSION.

FEET TO CENTIMETERS	
4'	8'
122	244

INCHES TO CENTIMETERS																	
inch	1/4"	1/2"	3/4"	1"	1.5"	2"	2.5"	3"	4"	5"	6"	7"	8"	9"	10"	11"	12"
cm	1	1.5	2	2.5	4	5	6.5	7.5	10	13	15	18	20	23	25	28	30



1/4" OR 1/2" THICK SECUROCK OR DENS DECK/DENS DECK PRIME

→ FASTENER & PLATE
 → CENTER LINE
 → GUIDE LINE

ADHERED SYSTEM

A-27.4

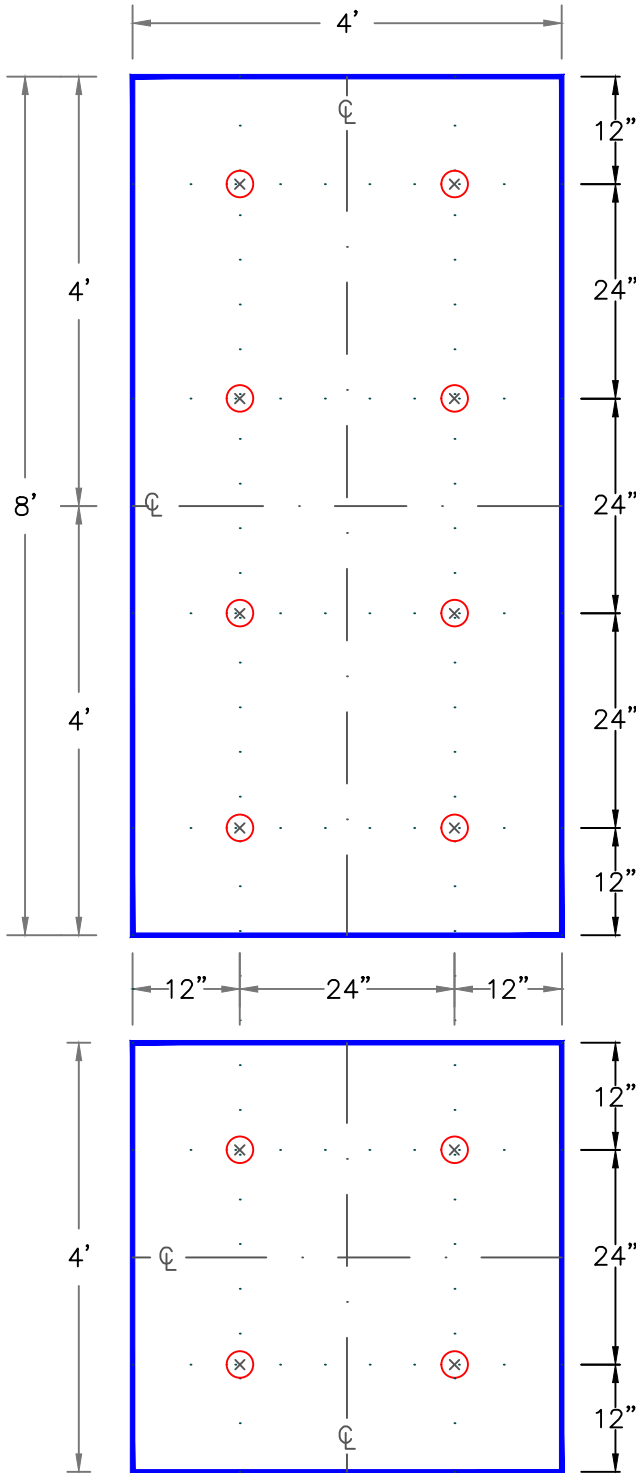

NOTES:

1. THIS DETAIL APPLIES TO 5/8" (16mm) THICK SECUROCK, DENS DECK PRIME, DENS DECK STORMX PRIME OR DURAFACER POLYISO (OVER AN APPROVED INSULATION) WHEN FASTENED INTO 22-GAUGE STEEL, STRUCTURAL CONCRETE, MINIMUM 15/32" (12mm) PLYWOOD OR 1-1/2" (38mm) THICK WOOD PLANK ROOF DECKS.
2. WHEN ENHANCED FASTENING IS REQUIRED AS PRESCRIBED IN FACTORY MUTUAL LOSS PREVENTION DATA SHEET 1-29, ANSI/SPRI WD-1 OR MIAMI-DADE COUNTY, REFER TO [VERSICO'S DESIGN REFERENCE DR-05-18.](#)
3. FOR CRITERIA ON INSULATION FASTENERS AND PLATES, REFER TO VERSICO SPECIFICATIONS.
4. IF A WIND SPEED WARRANTY GREATER THAN 55 MILES PER HOUR (25 METERS PER SECOND) OR A WARRANTY TERM GREATER THAN 20-YEARS IS SPECIFIED OR FOR SYSTEMS OVER 50'(15METERS), ADDITIONAL FASTENING MAY BE REQUIRED, REFER TO VERSICO SPECIFICATIONS.
5. DETAIL NOT FOR USE OVER ORIENTED STRAND BOARD, GYPSUM, FIBROUS CEMENT (TECTUM), LIGHTWEIGHT INSULATING CONCRETE OR STEEL ROOF DECK LESS THAN 22-GAUGE (0.8mm), [REFER TO DETAIL A-27.1](#) FOR ACCEPTABLE FASTENING.
6. WHEN INSTALLED OVER COMBUSTIBLE WOOD DECKS OR INSULATIONS, ALL JOINTS SHALL BE STAGGERED.
7. LONG UNINTERRUPTED RUNS >200' (>61M) OF SECUROCK MAY REQUIRE SLIGHT GAPPING DUE TO THERMAL EXPANSION.
8. DURAFACER POLYISO ACHIEVES UP TO A 20-YEAR, 90-MPH WARRANTY WITH (8) FASTENERS.

FEET TO CENTIMETERS	
4'	8'
122	244

INCHES TO CENTIMETERS																	
inch	1/4"	1/2"	3/4"	1"	1.5"	2"	2.5"	3"	4"	5"	6"	7"	8"	9"	10"	11"	12"
cm	1	1.5	2	2.5	4	5	6.5	7.5	10	13	15	18	20	23	25	28	30



5/8" THICK SECUROCK OR DENS DECK/DENS DECK PRIME/DENS DECK STORMX PRIME

→ FASTENER & PLATE
 → CENTER LINE
 → GUIDE LINE

ADHERED SYSTEM

A - 27.5

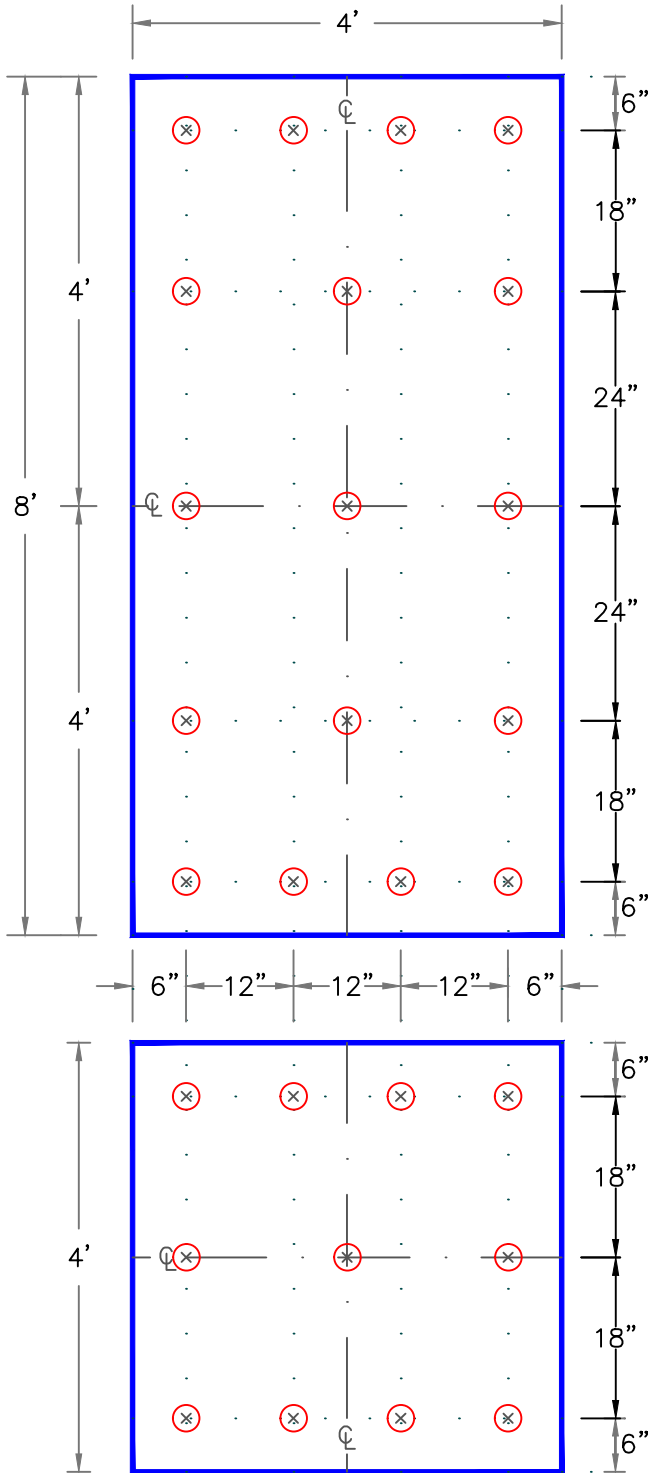

NOTES:

1. WHEN ENHANCED FASTENING IS REQUIRED AS PRESCRIBED IN FACTORY MUTUAL LOSS PREVENTION DATA SHEET 1-29, ANSI/SPRI WD-1 OR MIAMI-DADE COUNTY, REFER TO [VERSICO'S DESIGN REFERENCE DR-05-18.](#)
2. FOR CRITERIA ON INSULATION FASTENERS AND PLATES, REFER TO VERSICO SPECIFICATIONS.
3. IF A WIND SPEED WARRANTY GREATER THAN 55 MILES PER HOUR (25 METERS PER SECOND) OR A WARRANTY TERM GREATER THAN 20-YEARS IS SPECIFIED OR FOR SYSTEMS OVER 50'(15METERS), ADDITIONAL FASTENING MAY BE REQUIRED, REFER TO VERSICO SPECIFICATIONS.
4. OSB MUST BE POSITIONED WITH AN 1/8" (0.5cm) GAP BETWEEN BOARDS.
5. WHEN SPECIFIED, JOINTS IN OSB MUST BE STAGGERED WITH JOINTS IN INSULATION BELOW.

FEET TO CENTIMETERS	
4'	8'
122	244

INCHES TO CENTIMETERS																	
inch	1/4"	1/2"	3/4"	1"	1.5"	2"	2.5"	3"	4"	5"	6"	7"	8"	9"	10"	11"	12"
cm	1	1.5	2	2.5	4	5	6.5	7.5	10	13	15	18	20	23	25	28	30



OSB SHEATHING ATTACHMENT

→ FASTENER & PLATE
 → CENTER LINE
 → GUIDE LINE

ADHERED SYSTEM

A - 27.6

NOTES:

1. REFER TO VERSICO SPECIFICATIONS FOR PRODUCT DATA SHEETS FOR APPROPRIATE BEAD SPACING BASED UPON THE BUILDING HEIGHT, WARRANTY TERM AND ACCEPTABLE SUBSTRATE.
2. THE SURFACE TO WHICH ADHESIVE IS TO BE APPLIED SHALL BE DRY, FREE OF DUST, PROTRUSIONS, SHARP EDGES, LOOSE AND FOREIGN MATERIALS, OIL AND GREASE. AREA SHOULD BE CLEANED WITH AN AIR BLOWER.
3. PREVIOUSLY UNEXPOSED ASPHALT OR RESIDUE MUST BE PRIMED WITH VERSICO CAVGRIP, 702 OR 702LV PRIMER.
4. SEAL ALL GAPS IN THE CONCRETE DECK WITH VERSICO 725TR OR OTHER SUITABLE MATERIAL TO AVOID CONDENSATION ISSUES OR FILL WITH VERSICO INSULATION ADHESIVE.
5. AT THE BEGINNING OF THE INSULATION ATTACHMENT PROCESS AND PERIODICALLY THROUGHOUT THE DAY, CHECK THE ADHESION OF BOARDS TO ENSURE A TIGHT BOND IS CREATED AND MAXIMUM CONTACT IS ACHIEVED.
6. WALK THE BOARDS INTO THE ADHESIVE AND ROLL USING A 30" WIDE, 150 POUND SEGMENTED STEEL ROLLER TO ENSURE FULL EMBEDMENT.
7. ONE PERSON SHOULD BE DESIGNATED TO WALK AND ROLL IN ALL BOARDS. RELIEF CUT MAY BE NECESSARY TO ALLOW LIFTED BOARD TO LAY FLAT, OR CONSTANT WEIGHT (10LBS MINIMUM FOR 5-15 MINUTES PER LIFTED AREA) MAY BE NECESSARY TO ACHIEVE ADEQUATE ADHESION

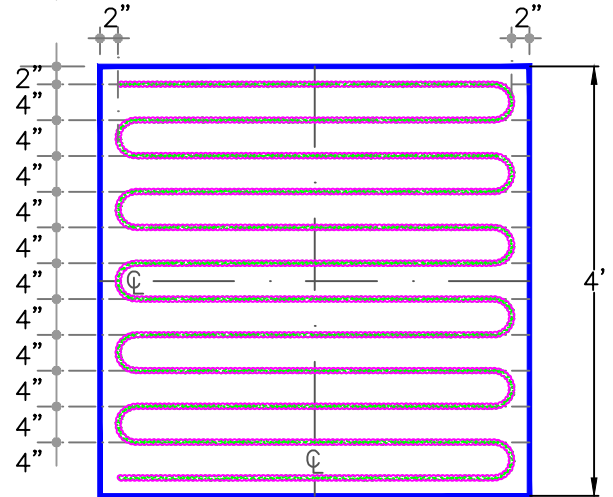
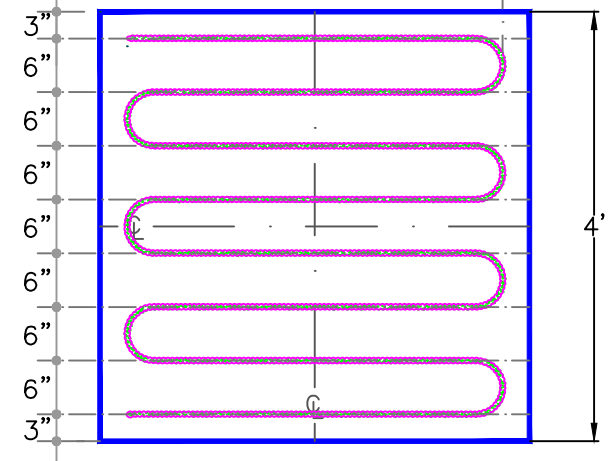
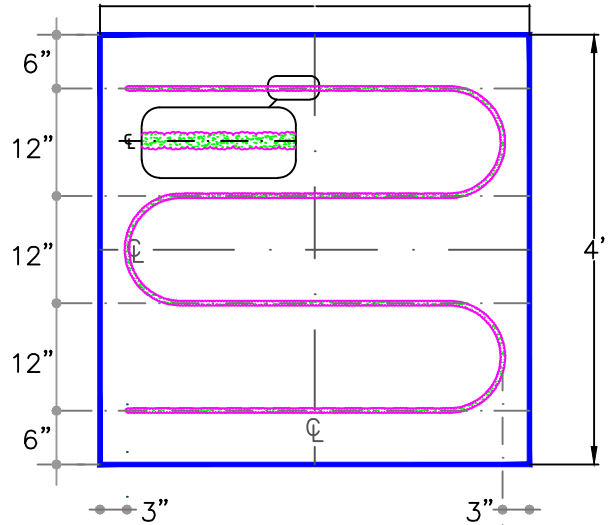

FEET TO CENTIMETERS	
4'	8'
122	244

INCHES TO CENTIMETERS																	
inch	1/4"	1/2"	3/4"	1"	1.5"	2"	2.5"	3"	4"	5"	6"	7"	8"	9"	10"	11"	12"
cm	1	1.5	2	2.5	4	5	6.5	7.5	10	13	15	18	20	23	25	28	30



INSULATION/COVER BOARD ATTACHMENT USING BEAD ADHESIVE

→ FOAM ADHESIVE
 → CENTER LINE
 → GUIDE LINE

ADHERED SYSTEM

A - 27.7

NEW CONSTRUCTION OR RE-ROOF/TEAR OFF
PROJECTS WITH SECUROCK, DENS-DECK, RECOVERY
BOARD OR ANY
VERSICO APPROVED INSULATION MIN 1-1/2"
(38mm) THICK

RE-ROOF/NO TEAR OFF PROJECTS WITH
POLYISOCYANURATE LESS THAN 1-1/2"
(38mm) THICK

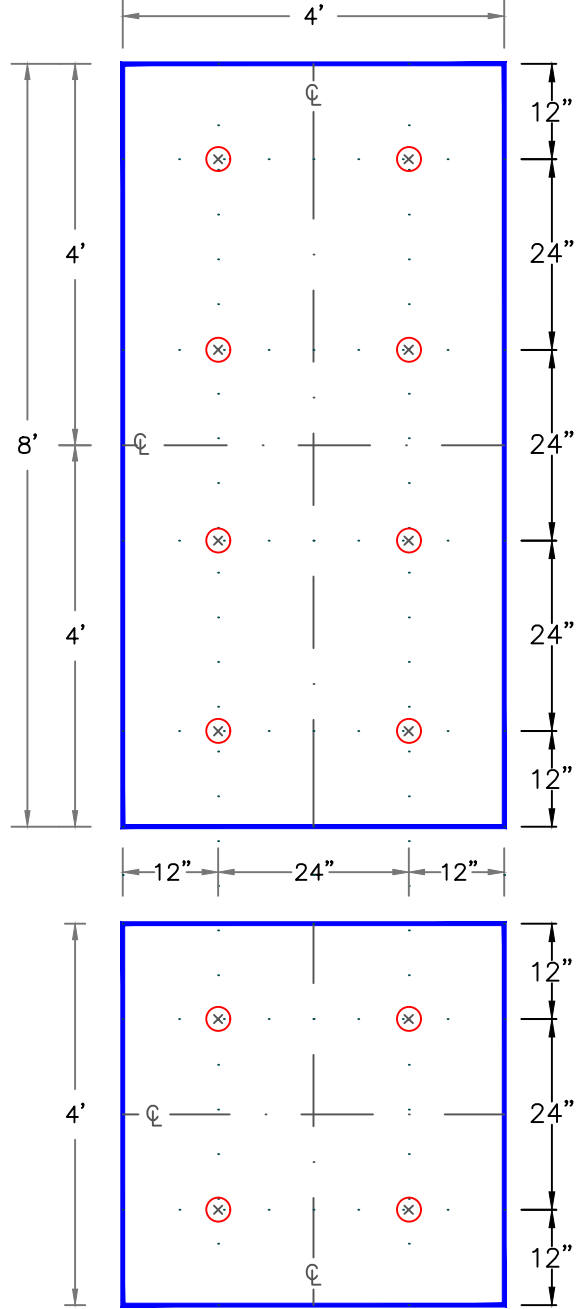
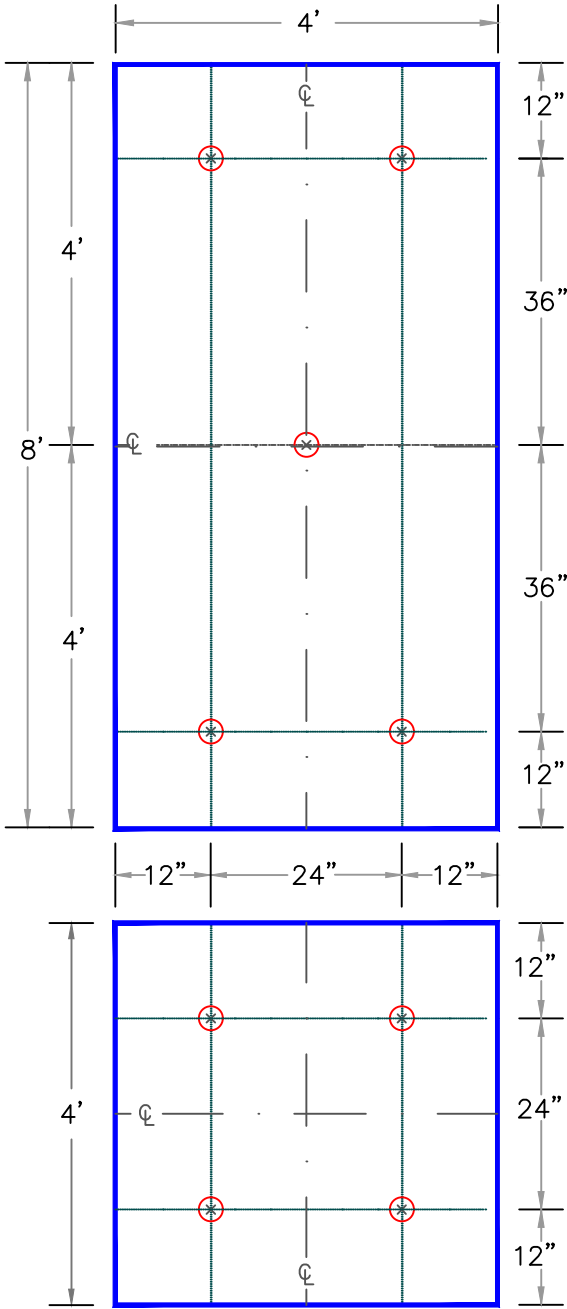

NOTE:

FOR CRITERIA ON INSULATION FASTENERS AND PLATES, REFER TO VERSICO SPECIFICATIONS.

FEET TO CENTIMETERS		INCHES TO CENTIMETERS																	
4'	8'	inch	1/4"	1/2"	3/4"	1"	1.5"	2"	2.5"	3"	4"	5"	6"	7"	8"	9"	10"	11"	12"
122	244	cm	1	1.5	2	2.5	4	5	6.5	7.5	10	13	15	18	20	23	25	28	30



INSULATION/COVER BOARD ATTACHMENT FOR ALL WARRANTY DURATIONS

- FASTENER & PLATE
- CENTER LINE
- GUIDE LINE

MECHANICALLY ATTACHED SYSTEM

MA-27

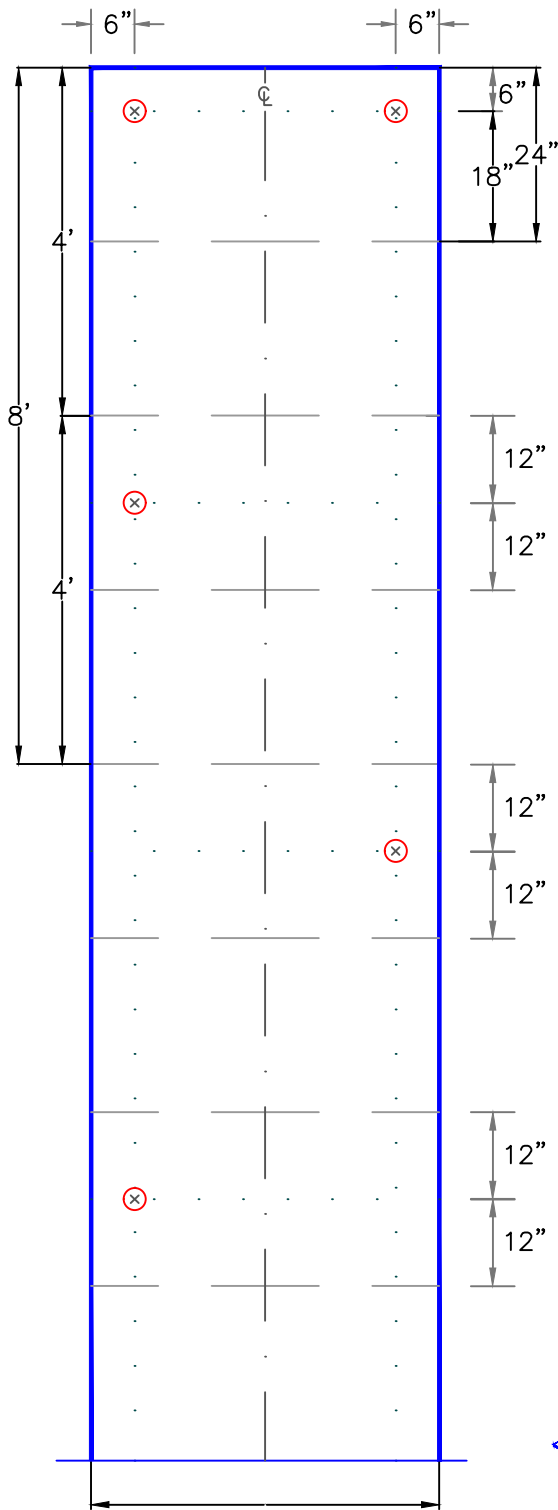

NOTES:

1. INSTALL R-TECH RECOVER BOARD WITH CONTINUOUS SIDE JOINTS AND END JOINTS STAGGERED SO THEY ARE OFFSET BY A MINIMUM OF 12" (30cm) FROM THE END JOINTS IN ADJACENT ROWS.
2. INSULATION SHOULD ABUT TIGHTLY AGAINST ADJACENT BOARDS.
3. IF R-TECH FANFOLD RECOVER BOARD IS BEING INSTALLED OVER AN EXISTING LAYER OF INSULATION, ALL JOINTS MUST BE OFFSET A MINIMUM OF 6" (15cm) BETWEEN LAYERS.
4. FASTENERS SHOULD NEVER BE CLOSER THAN 6" (15cm) FROM THE EDGES OF THE BOARD.
5. CARE MUST BE TAKEN TO AVOID OVERDRIVING OR UNDER-DRIVING THE FASTENER AND PLATE ASSEMBLY.
6. METALLIC FACER PERMITS THE USE OF R-TECH RECOVER BOARD UNDER EPDM MECHANICALLY ATTACHED ASSEMBLIES IN NORTHERN CLIMATES (CONTACT VERSICO FOR ACCEPTANCE).

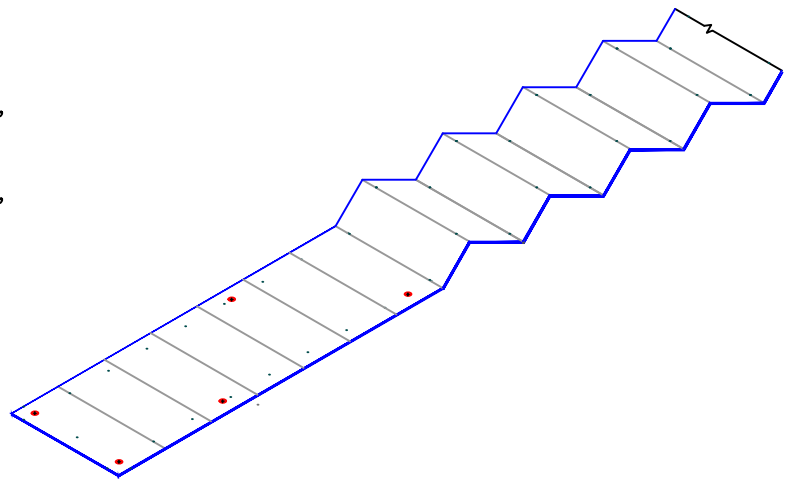

FEET TO CENTIMETERS	
4'	8'
122	244

INCHES TO CENTIMETERS																	
inch	1/4"	1/2"	3/4"	1"	1.5"	2"	2.5"	3"	4"	5"	6"	7"	8"	9"	10"	11"	12"
cm	1	1.5	2	2.5	4	5	6.5	7.5	10	13	15	18	20	23	25	28	30



R-TECH FANFOLD ROOF UNDERLAYMENT

→ FASTENER & PLATE
 → CENTER LINE
 → GUIDE LINE

MECHANICALLY ATTACHED SYSTEM

MA-27.3

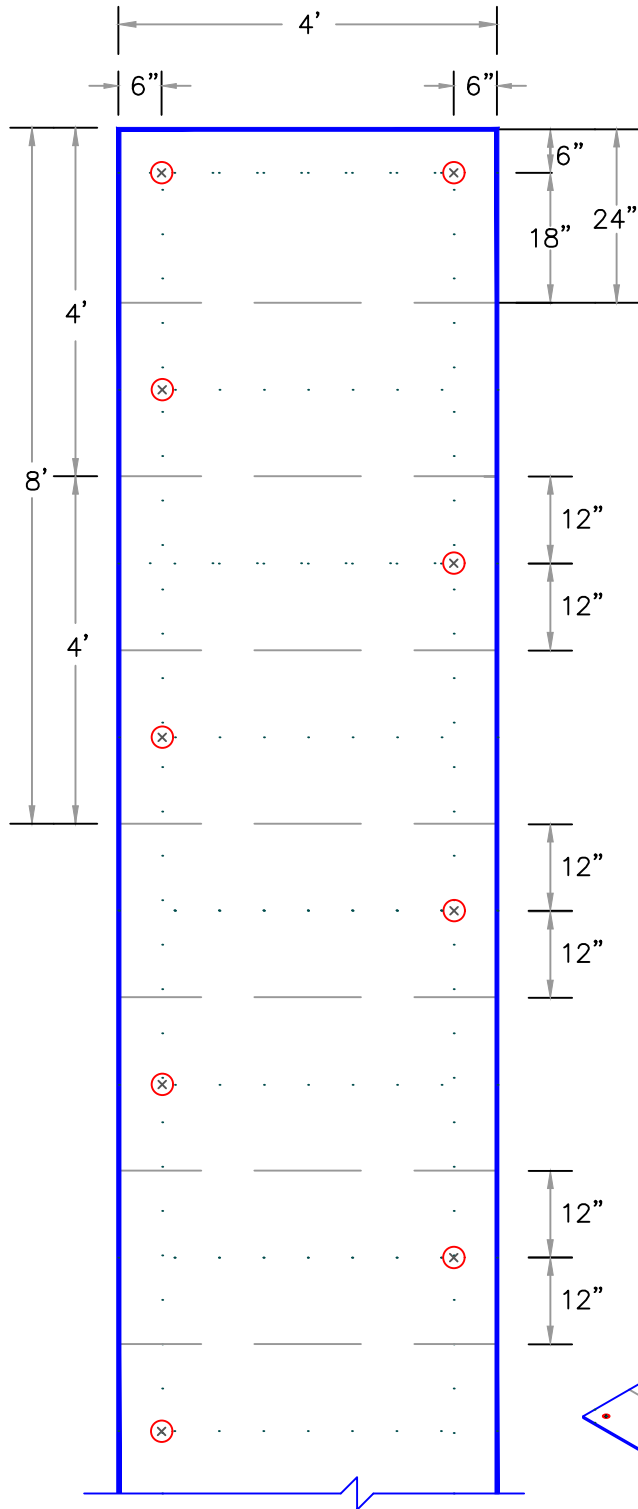

NOTES:

1. INSTALL R-TECH RECOVER BOARD WITH CONTINUOUS SIDE JOINTS AND END JOINTS STAGGERED SO THEY ARE OFFSET BY A MINIMUM OF 12" (30cm) FROM THE END JOINTS IN ADJACENT ROWS.
2. INSULATION SHOULD ABUT TIGHTLY AGAINST ADJACENT BOARDS.
3. IF R-TECH FANFOLD RECOVER BOARD IS BEING INSTALLED OVER AN EXISTING LAYER OF INSULATION, ALL JOINTS MUST BE OFFSET A MINIMUM OF 6" (15cm) BETWEEN LAYERS.
4. FASTENERS SHOULD NEVER BE CLOSER THAN 6" (15cm) FROM THE EDGES OF THE BOARD.
5. CARE MUST BE TAKEN TO AVOID OVERDRIVING OR UNDER-DRIVING THE FASTENER AND PLATE ASSEMBLY.
6. METALLIC FACER PERMITS THE USE OF R-TECH RECOVER BOARD UNDER EPDM MECHANICALLY FASTENED ASSEMBLIES IN NORTHERN CLIMATES (CONTACT VERSICO FOR ACCEPTANCE).
7. FOR NON-FM ASSEMBLY REFER TO DETAIL MF-27.3

FEET TO CENTIMETERS	
4'	8'
122	244

INCHES TO CENTIMETERS																	
inch	1/4"	1/2"	3/4"	1"	1.5"	2"	2.5"	3"	4"	5"	6"	7"	8"	9"	10"	11"	12"
cm	1	1.5	2	2.5	4	5	6.5	7.5	10	13	15	18	20	23	25	28	30



R-Tech FANFOLD ROOF UNDERLAYMENT FOR FM ASSEMBLIES

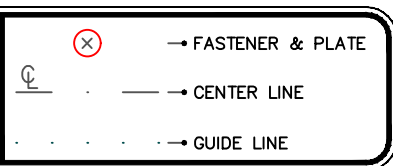

MECHANICALLY ATTACHED SYSTEM
MA-27.4

NEW CONSTRUCTION OR RE-ROOF/TEAR OFF PROJECTS WITH 1/2" SecurShield HD COATED GLASS FACER

NEW CONSTRUCTION OR RE-ROOF/TEAR OFF PROJECTS WITH 20 OR 25 PSI SecurShield ANY THICKNESS

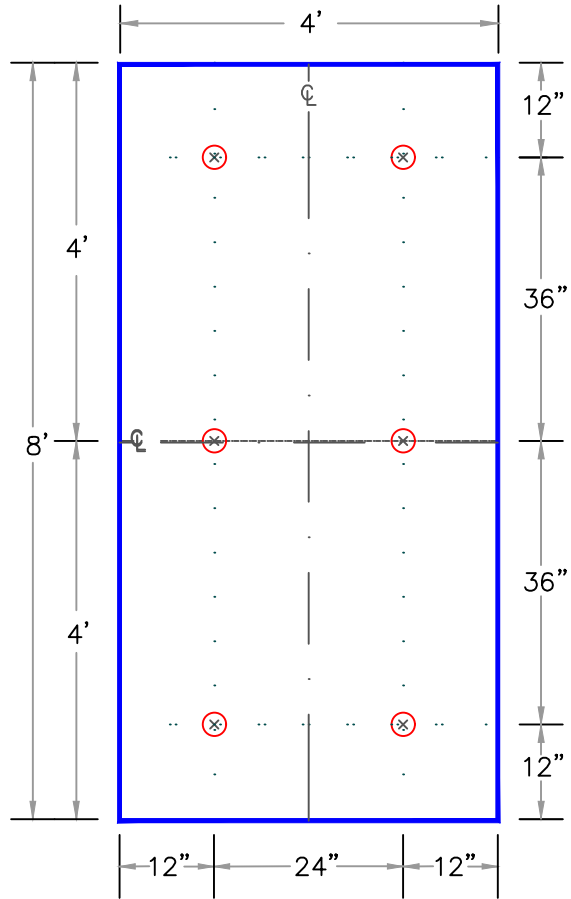
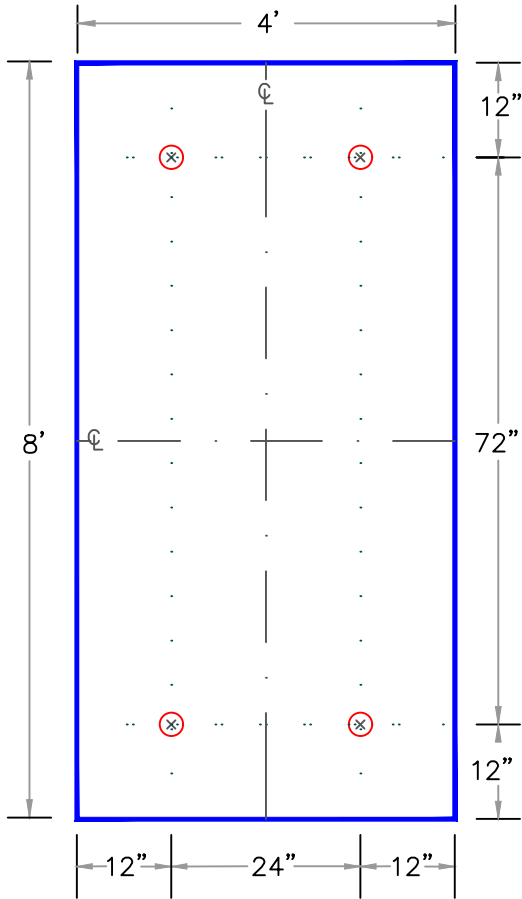

FEET TO CENTIMETERS	
4'	8'
122	244

INCHES TO CENTIMETERS																	
inch	1/4"	1/2"	3/4"	1"	1.5"	2"	2.5"	3"	4"	5"	6"	7"	8"	9"	10"	11"	12"
cm	1	1.5	2	2.5	4	5	6.5	7.5	10	13	15	18	20	23	25	28	30



INSULATION/COVERBOARD ATTACHMENT WHEN USING SecurShield FAMILY PRODUCTS FOR ALL WARRANTIES LENGTHS

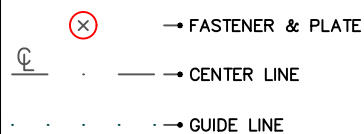

MECHANICALLY ATTACHED SYSTEM

MA-27.5

Copyright 2024 Versico

Versico and the Versico logo are Trademarks of Versico

Dens Deck and Dens Deck Prime are Trademarks of Georgia-Pacific Gypsum LLC

This specification represents the applicable information available at the time of its publication. Owners, specifiers and Versico authorized roofing contractors should consult Versico or their Versico Independent Sales Representative for any information, which has subsequently been made available.

Review the appropriate Versico warranty for specific warranty coverage, terms, conditions and limitations.



SPECIFICATION

SUPPLEMENT

G-09-20

Aqua Base 120 Bonding Adhesive

January 2024

The information contained in this supplement serves as a criteria for Specifiers and Authorized Contractors regarding the design and installation of Versico Roofing Systems and related products. Additional information essential for the design and installation of the Roof Systems mentioned herein are also included in the respective Specification for each Roof System and in the Design Reference Section of the Versico Technical Manual. Specifiers and Authorized Contractors are advised to reference all applicable sections.

Aqua Base 120 Bonding Adhesive may be used as a one-sided, wet lay-in adhesive on horizontal surfaces with VersiFleece TPO membrane. It can also be used as a two-sided contact adhesive with standard EPDM or TPO membranes.

NOTE: The use of Aqua Base 120 Bonding Adhesive to adhere VersiFleece membrane directly to lightweight insulating concrete is not permitted.

A. General Cautions and Warnings

1. Review the applicable Safety Data Sheet for complete safety information prior to use.
2. This adhesive is designed to be applied when the ambient temperature is 40°F (4°C) and rising. Do not apply if ambient temperature will drop below 32°F (0°C) before adhesive dries. Do not allow to freeze. Do not store below 40°F (4°C).
3. **Extended drying times can be expected in cool, overcast, humid, shaded or late day applications. The adhesive must be dry to avoid permanent blisters from trapped moisture.**
4. Opened containers of Aqua Base 120 Bonding Adhesive should be used within 48 hours. The adhesive will form a thick surface skin that will not re-dissolve. Adhesive can be used once the skinned layer is removed.
5. Aqua Base 120 Bonding Adhesive is not acceptable over existing roof systems or decks with residual adhesive or asphalt. A porous substrate is required for Aqua Base to work properly.
6. Immediately roll the bonded portion of the sheet with a 30" wide, 150 lb segmented, weighted steel roller to achieve maximum contact. **Rolling is critical.**
7. When selecting an approved underlayment from the Table included in this specification supplement, the corresponding specification should be referenced to determine the acceptable underlayment attachment method.
8. Tables included in Warranty Section of the appropriate Roofing System Specification contain various fastening densities which shall be referenced.

B. Warranty Considerations

Projects incorporating the use of **Aqua Base 120 Adhesive** are limited to warranties with peak gust wind speed coverage of 55 mph, see “**Aqua Base Warranty Criteria**” Table. Versico may be contacted for projects where greater warranty coverage is required.

Aqua Base Warranty Criteria

Membranes	Membrane Adhesion Method	Warranty Duration	
		Up to 15 Year	20 Year Max
		Minimum Underlayments (1)	
EPDM and TPO (Non-Fleece)	Two Sided Contact Method (Adhesive applied to both surfaces)	1-1/2" (20-psi) Polyisocyanurate or SecurShield	1-1/2" (20-psi) Polyisocyanurate or SecurShield
		7/16" Oriented Strand Board (OSB) or 15/32" 5-Ply Plywood	7/16" Oriented Strand Board (OSB) or 15/32" 5-Ply Plywood
		1/2" SecurShield HD or HD Plus	1/2" SecurShield HD or HD Plus
		1/4" Securock (2)	1/2" Securock (2)
		Structural Concrete or Cellular Lightweight Concrete(3)	Structural Concrete or Cellular Lightweight Concrete(3)
VersiFleece (EPDM and TPO)	Wet Lay-in Method (Adhesive applied to substrate only)	1-1/2" (20-psi) Polyisocyanurate or SecurShield	1-1/2" (20-psi) SecurShield
		7/16" Oriented Strand Board (OSB) or 15/32" 5-Ply Plywood	7/16" Oriented Strand Board (OSB) or 15/32" 5-Ply Plywood
		1/2" SecurShield HD or HD Plus	1/2" SecurShield HD or HD Plus
		1/4" Securock (2)	1/4" Securock (2)
		Structural Concrete	Structural Concrete

(1)All Versico Products listed for higher duration coverage can also be used for Warranties for lower duration coverage. (i.e. 20 YR underlayment may be used for 15 YR underlayment).

(2)Application over insulation only.

(3) Over Vented Steel Deck

(4) VersiFleece EPDM and water-based adhesives should not be used over coated glass facer.

C. Application

1. Stir the Aqua Base 120 Bonding Adhesive until settled material or phased liquid is redistributed and the adhesive is uniform in color.
2. Apply adhesive to the membrane and the substrate (at the recommended rate) in a uniform manner avoiding globs, puddles, and uncoated areas.
3. The typical application rate is approximately 100-120 square feet per gallon/ finished surface. (Applied to membrane and substrate when used as contact adhesive). Refer to Technical Data Bulletin for additional information.
4. Application methods:

- a) Roller Application – Use a medium nap roller.
- b) Mechanical Roller Application – Follow the manufacturer’s safety and use procedures.
- c) Mechanical Spray Application – Follow the manufacturer’s safety and use procedures.
 - 1) Tip sizes between .017" to .025" in a Graco Ultra or ULTRA Max II gun.
 - 2) A minimum fluid pressure of 2,500 psi is required for a fair pattern.
 - 3) Back rolling is recommended.
 - 4) Flush with water at the end of the day.

5. **Two-sided Contact Method** (Standard Membrane):

- a) Apply Aqua Base 120 Bonding Adhesive to the membrane and the substrate at the recommended rate.
 - 1) The adhesive must be allowed to dry until it turns translucent and does not transfer to a dry finger touch or pull away from the membrane. The dried adhesive should remain tacky before assembly.
 - 2) Mate the membrane with the adhesive-coated substrate, while avoiding wrinkles.
 - 3) Immediately roll the bonded portion of the sheet with a 30" wide, 150 lb segmented, weighted steel roller to achieve maximum contact.

CAUTION: Pay particular attention to rolling the membrane along the insulation joints due to the slight step-off of the facer. The adhesive contains no solvents to react with the membrane, and therefore rolling the sheet is critical.

NOTE: Extended drying times can be expected in cool, overcast, humid, shaded or late day applications. The adhesive must be dry to avoid permanent blisters from trapped moisture.

- 4) Coated areas exposed to moisture shall be allowed to dry and then recoated.
- 5) All adhesive residues in the splice area must be removed.
- b) **For vertical walls,** Let the wall flashing membrane relax and warm to minimize the natural tendency of the membrane to curl.
 - 1) Apply a medium to heavy coat of adhesive to the wall first and then a standard coat to the flashing membrane and allow thorough drying. Adhesive will turn translucent in color when dry.

CAUTION: Not allowing the adhesive to dry completely will result in poor adhesion strength or blisters occurring over time.

- 2) Mate the membrane with the adhesive-coated wall, while avoiding wrinkles.
- 3) Immediately broom the bonded portion of the sheet with a stiff-bristle push-broom and roll the membrane, starting in the angle change and working the membrane up the wall, using a 3"-wide "J" roller (preferred) to achieve maximum contact. Roll up from the base evenly and work in small sections gaining good attachment at the lower portions before moving up to the top of the membrane.

NOTE: Temporary pinning or taping the top membrane edge to the wall may be necessary to prevent membrane curl back until the termination detail can be completed.

6. **Wet Lay-in Method** (VersiFleece EPDM/TPO Membrane)

- a) Coat the substrate with Aqua Base 120 Bonding Adhesive and roll VersiFleece EPDM/TPO 100-, 115- or 135-mil membrane into the wet adhesive.
 - 1) Avoid heavy or thin application of adhesive. Immediately install the membrane while the adhesive is still wet. If adhesive has become translucent, recoat with additional adhesive.

CAUTION: Care must be taken with the "barn door" method of sheet installation to avoid dry (translucent) adhesive. Lift the membrane in a few areas to ensure adhesive is transferring to the fleece.

2) Roll with a 150 lb segmented, weighted steel roller to achieve maximum contact.

NOTE: Pay particular attention to rolling the membrane along the insulation joints due to the slight step-off of the facer. All adhesive residue in the splice area must be removed.

3) Cure rates are between 12-72 hours depending on porosity of substrate and weather conditions. Re-rolling within 24 hours may be necessary if the substrate is uneven or the sheet contains some fullness. Temporary weighting of the membrane may be necessary until the adhesive cures to address pronounced sheet fullness.

CAUTION: Do not use the VersiFleece AC membranes for the wet lay-in application.

b) **For vertical walls,** Coat the fleece backing and allow the adhesive to completely dry.

1) Test for dryness by pressing the back of a finger into the fleece to check that the adhesive is dry throughout the fleece layer.

2) Once the adhesive on the fleece is dry, apply a standard coat of adhesive to the wall and a second coat to the fleece backing and allow drying. Adhesive will turn translucent in color when dry.

3) Mate the membrane with the adhesive-coated wall, while avoiding wrinkles.

4) Immediately broom the bonded portion of the sheet with a stiff-bristle push-broom or roll the membrane using a 3"-wide "J" roller (preferred) to achieve maximum contact.

CAUTION: Please note the fleece will develop a dry top surface while still holding moisture in the fleece and does require complete drying prior to the mating of the membrane to the wall substrate. Installing the membrane while the adhesive is still wet will trap moisture and cause blisters or loose membrane.

NOTE: Extended drying times can be expected in cool, overcast, humid, shaded or late day applications. The adhesive must be dry to avoid permanent blisters from trapped moisture.

5) Coated areas exposed to moisture shall be allowed to dry and then recoated.

6) All adhesive residue in the splice area must be removed.

Copyright 2024 Versico

Versico, VersiGard, VersiWeld, VersiFlex and VersiFleece are Trademarks of Versico.

This Design Reference represents the applicable information available at the time of its publication. Owners, specifiers and Contractors should consult Versico or their Versico Independent Sales Representative for any information that has subsequently been made available.

Review the appropriate Versico Warranty for specific warranty coverage, terms, conditions and limitations



SPECIFICATION

SUPPLEMENT

G-10-18

Metal Edging and Details

January 2024

The information contained in this supplement serves as a criteria for Specifiers and Authorized Contractors regarding the design and installation of Versico Roofing Systems and related products. Additional information essential for the design and installation of the Roof Systems mentioned herein are also included in the respective Specification for each Roof System and in the Design Reference Section of the Versico Technical Manual. Specifiers and Authorized Contractors are advised to reference all applicable sections.

Introduction

One of the leading causes of wind related disturbances is improperly designed, manufactured or installed metal fascia systems. Most of the time, shop fabricated metal accessories do not meet industry recognized standards.

Countless studies, many initiated by hurricanes, have pointed to metal edge components as a major contributor to roof failures. These components are vulnerable since the building edge is first hit, with winds and uplift pressures are always greatest at perimeters and especially roof corners.

General

When metal edging or coping is to be installed (particularly when shop fabricated), it is strongly advised that the design conforms with the Factory Mutual recommendations identified in Loss Prevention Data Bulletin 1-49 and with SMACNA (Sheet Metal and Air Conditioning National Association) specifications. To ensure such compliance, specify FM 1-90 approved metal edge systems should be specified.

The securement of perimeter wood nailers, play an equally important role in the overall performance of metal fascia systems. Design Criteria for the attachment of wood nailers and associated metal edge components are also identified in the FM 1-49 Bulletin and summarized in the [Design Reference DR-08-11 "Wood Nailers and Securement Criteria"](#). This information should be referenced when selecting an appropriate attachment method.

Often, metal edging costs are solely judged on the material linear foot cost itself alone. Significant savings can be realized when closer attention is given to overall installed costs, where labor and associated material savings are factored in. Edge systems that minimize flashing material and reduce installation time can be of significant benefit when looking at overall roof edge costs. Products reusability (for the purpose of repairs and eventual roof replacement) is also seldom accounted for, although the owner can recognize overall life cycle cost savings if properly evaluated.

Versico Edging/Coping

Versico supplies a wide range of metal fascia systems which meet the ES-1 design guidelines and carry FM Class 1-90 approval or greater. Versico's metal edging is also covered by the Versico Membrane System Warranty. Contact Versico for detailed information concerning available pre-fabricated metal edging and coping.

Pre-Fabricated Edgings and Copings

1. **VersiTrim 200 Fascia:** A snap-on edge system consisting of a 24 gauge galvanized metal water dam and 40, 50 or 63-mil thick aluminum Kynar 500, clear and colored anodized finish or 22 or 24 gauge steel, Kynar 500 finish. The fascia is available in a variety of colors and heights varying from 5" to 12-1/2". Custom fascias and colors are available upon request. ANSI/SPRI/FM-4435 ES-1 certified.
2. **VersiTrim 300 Fascia System:** A snap-on edge system consisting of a 24 gauge galvanized metal spring clip water dam and 50 or 63-mil thick aluminum Kynar 500, colored anodized finish or 24 gauge steel, Kynar 500 finish. The

fascia is available in a variety of colors and heights varying from 5" to 10". Custom fascias and colors are available upon request. ANSI/SPRI/FM-4435 ES-1 certified.

3. **VersiTrim 2000 Standard Fascia:** An anchor bar roof edge fascia system consisting of heavy .100" thick extruded aluminum bar, corrosion resistant stainless steel fasteners and snap-on fascia cover used with Adhered, Mechanically Fastened assemblies. Refer to installation instructions for various sizes, colors and accessories ANSI/SPRI/FM-4435 ES-1 certified. Also available in **VersiTrim 2000 Extended Fascia** (Up to 13" Face Height) and **VersiTrim 2000 Canted Fascia**.
4. **VersiTrim 3000 Roof Edge System:** A metal anchor bar fascia system consisting of a 20 gauge steel retainer bar, corrosion resistant fasteners and a 32, 40, 50 or 63-mil thick aluminum or 24 gauge steel snap-on fascia cover. It is for use in Fully Adhered and Mechanically Fastened Roofing Systems. ANSI/SPRI/FM-4435 ES-1 certified. Also available in **VersiTrim 3000XT Roof Edge System** (Up to 13" Face Height) with an extruded aluminum retainer bar for added performance.
5. **VersiTrim One Fascia System:** A snap-on edge system consisting of a 20 gauge steel or 50-mil aluminum retainer bar, corrosion resistant fasteners and a 24 gauge or 40, 50 or 63-mil Kynar finished aluminum fascia cover. Available in face sizes up to 8". ANSI/SPRI/FM-4435 ES-1 certified.
6. **VersiTrim 200 Coping:** A snap-on coping system that incorporates 20 gauge anchor cleats with pre-slotted holes, a concealed joint cover and 10' or 12' continuous sections of coping cap consisting of 40, 50 or 63-mil thick Kynar 500, clear and colored anodized finish or 24 gauge steel, Kynar 500 finish. The coping cap is available in a variety of colors and widths. Custom pieces such as tees, crosses, radius copings, etc., are also available. ANSI/SPRI/FM-4435 ES-1 certified. Also available in **VersiTrim 200 Gold Coping** with 16 gauge anchor cleats for added performance and **VersiTrim 200 Cantilever Coping** for parapet walls with a non-structural exterior building facade.
7. **VersiTrim 300 Coping:** A snap-on coping system that incorporates 20 gauge anchor cleats with pre-slotted holes, a concealed joint cover and 12' continuous sections of coping cap consisting of 40, 50 or 63-mil thick Kynar 500, clear and colored anodized finish or 24 gauge steel, Kynar 500 finish. The coping cap is available in a variety of colors and widths. Custom pieces such as tees, crosses, radius copings, etc., are also available. ANSI/SPRI/FM-4435 ES-1 certified. Also available in **VersiTrim 300 Plus Coping** with 16 gauge anchor cleats for added performance.
8. **VersiTrim One Coping:** A mechanically fastened coping system consisting of a 22 gauge retainer bar (face side only), corrosion resistant fasteners and a 24 gauge or 0.040 aluminum Kynar finished coping cover. The coping cover is secured by clipping on the retainer bar and fastened on the backside with corrosion resistant fasteners (with rubber washer). Available for wall thicknesses up to 12". ANSI/SPRI/FM-4435 ES-1 Certified.
9. **VersiTrim Drip Edge:** Designed for use on Fully Adhered and Mechanically Attached Roofing Systems. Includes a 22 gauge continuous 12' pre-punched 90-degree angle cleat and 10' or 12' long fascia sections. Incorporates concealed joint covers and strong 1-1/4" ring shank nails to provide long-term holding power. A selection of colors in 24 gauge steel, Kynar[®] 500 and 32-mil aluminum finish or Kynar 500 is available. ANSI/SPRI/FM-4435 ES-1 Certified.
10. **VersiTrim Heat-Weldable Drip Edge:** Pre-fabricated PVC or TPO-coated metal edging. Heat-weld membrane directly to edge. Available in sizes up to 8" fascia height and in colors: white, gray or tan. Also available with factory-applied TPO or PVC flashing.
11. **VersiTrim Term Bar Fascia:** A 1.75" wide formed aluminum termination bar with pre-slotted fastening holes for ease of locating and installing. The decorative cover is available in 0.040" aluminum or 24-gauge galvanized steel. VersiTrim Term Bar Fascia is manufactured in 12' lengths for fewer joints/seams, fewer sections to handle and faster installation.

Versico Metal Edging			
Product	Type	FM Approval	ES-1 Compliant
VersiTrim 300	Coping	1-90 (20 ga cleat)	Yes
VersiTrim 300	Fascia	1-135	Yes
VersiTrim 3000	Fascia	1-135	Yes
VersiTrim 3000XT	Fascia	1-135	Yes
VersiTrim 200	Coping	1-90	Yes
VersiTrim 200	Fascia	1-150	Yes
VersiTrim 2000	Fascia	1-225	Yes
VersiTrim 2000	Extended Fascia	1-135	Yes
VersiTrim 2000	Canted Fascia	1-105	Yes
VersiTrim One	Fascia	1-120	Yes

Shop Fabricated Edging

A. Supplied by Versico

1. **VersiWeld Coated Metal:** A 24-gauge galvanized steel sheet coated with a layer of non-reinforced VersiWeld Flashing. The sheet is cut to the appropriate width and used to fabricate metal drip edges or other roof perimeter edging profiles. VersiWeld Membrane may be heat welded directly to the coated metal. Coated metal is available in sheets 4' x 10' and comes packaged 25 sheets per pallet (also available packaged 10 sheets per pallet on a direct ship basis). Available in white, gray or tan.
2. **VersiFlex PVC Coated Metal:** A 24-gauge galvanized steel sheet coated with a layer of non-reinforced VersiFlex Flashing. The sheet is cut to the appropriate width and used to fabricate metal drip edges or other roof perimeter edging profiles. VersiFlex Membrane may be heat welded directly to the coated metal. Coated metal is available in sheets 4' x 10' and comes packaged 10 sheets per pallet. Available in white, gray or tan.
3. **Versico PVDF (Kynar) Coated Metal:** Galvalume steel or 3000 series Aluminum sheet coated with a PVDF (Kynar) finish. The sheet is cut to the appropriate width and used to fabricate metal coping or roof perimeter fascia profiles. Versico metal flat sheets are available in 31 colors in 4'x10' sheets. Mill finish aluminum, anodized aluminum and bare G90 steel are available.

B. Shop Fabricated Edging Requirements

1. Shop Fabricated Metal Edging and Coatings must comply with SMACNA standards and design parameters outlined in the NRCA Waterproofing Manual. For ES-1 compliance, NRCA website should be accessed to determine required ES-1 certification.

Guide for Sheet Metal Fascia Edges

(Reprinted from the NRCA Roofing and Waterproofing Manual - Fourth Edition)

Recommended Minimum Gauges for Fascia and Cleat ¹				
Exposed Face Without Brakes "A" Dimension	Aluminum Alloy (3003-H14)	Galvanized or Coated (G60 & G90) Steel	Stainless Steel (302 & 304)	Cleat ²
Up to 3" Face	.032"	24 ga.	26 ga.	Same gauge as fascia metal
3" to 6" Face	.040"	24 ga.	24 ga.	One gauge heavier than fascia metal
6" to 8" Face	.040"	24 ga.	24 ga.	One gauge heavier than fascia metal
8" to 10" Face	.050"	22 ga.	22 ga.	One gauge heavier than fascia metal
More Than 10"	Add brakes to stiffen or use two-piece face	Add brakes to stiffen or use two-piece face	Add brakes to stiffen or use two-piece face	One gauge heavier than fascia metal

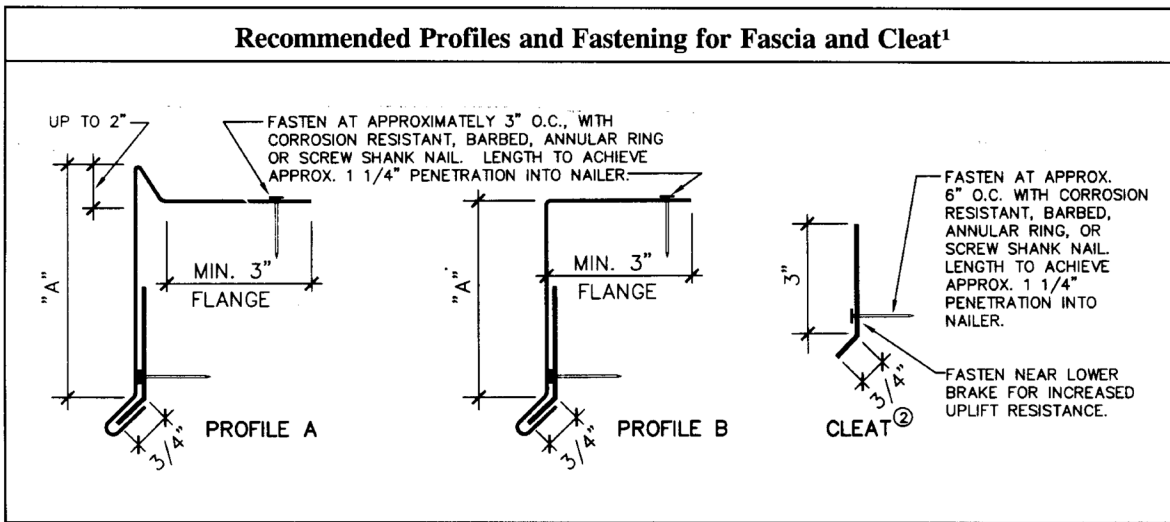

Notes:

1. Consideration must be given to wind zone and local conditions in regard to the selection of metal gauge, profile, and fastening schedule. Severe conditions or code and regulatory bodies may require more conservative designs. When using the above table, additional items should be considered, such as fastening pattern.
2. All cleats shall be continuous with lengths not to exceed 12 feet. Allow a 1/4" gap between pieces. Joints in cleat should not coincide with joints in fascia metal.
3. Inclusion of shop fabricated metal edging in the Versico Membrane System Warranty is limited to warranties with a duration of 20 years or less and peak wind speed coverage of less than 80 mph.

Copyright 2024 Versico

Versico and VersiTrim are Trademarks of Versico

This specification represents the applicable information available at the time of its publication. Owners, specifiers and Versico authorized roofing contractors should consult Versico or their Versico Independent Sales Representative for any information, which has subsequently been made available.

Review the appropriate Versico warranty for specific warranty coverage, terms, conditions and limitations.



SPECIFICATION

SUPPLEMENT

G-11-20

LIQUISEAL Liquid Flashing

January 2024

The information contained in this supplement serves as a criteria for Specifiers and Authorized Contractors regarding the design and installation of Versico Roofing Systems and use of liquid flashing to complete tie-in details and flash unusual and round penetrations. In addition to the information contained herein, attachment details 1 through 3 are included to provide the Specifiers and Authorized Contractors with quick access to specific information. Specifiers and Authorized Contractors are advised to reference all applicable details included with this spec supplement.

A. General

LIQUISEAL Liquid Flashing is a two-component, polyurethane-based system which creates a reinforced, cold-applied liquid flashing that is compatible with all Versico EPDM, TPO, PVC, and KEE HP membranes. LIQUISEAL Liquid Flashing is designed for use with oddly shaped penetrations and tying together dissimilar roofing systems without building an isolation curb or impeding drainage. LIQUISEAL Liquid Flashing is UV- and color-stable, solvent-free, low-VOC, and virtually odorless.

LIQUISEAL Liquid Flashing consists of the following products:

1. **LIQUISEAL Resin** – Two-component polyurethane-based resin, when mixed will be white or gray in color. Available in 0.56 gallon (2.1 l) sachets and 1.03 gallon (3.9 l) pails. Coverage rate of 13.6 square feet (1.26 meters square) per gallon (3.8 l).
2. **LIQUISEAL Fleece** – 50-mil thick, white, Non-woven, needle-punched polyester fabric reinforcement. Available in rolls of 13.8" (350 mm) and 27" (685 mm) widths by 164'-0" (50 m) length.
3. **LIQUISEAL Metal Primer** – A solvent-free, high solids, two-part, cold-applied polyurethane resin. Used to prime metal, EPDM, and other non-porous surfaces. Available in 0.25 gallon (0.9 l) sachets. Coverage rate of 25 square feet (2.3 square meters) per 0.25 gallon (0.9 l) sachet.
4. **LIQUISEAL Concrete & Masonry Primer** – A solvent-free, two-part, cold-applied liquid epoxy resin. Used with Surfacing Sand to prime concrete, masonry, and other porous surfaces. Available in 0.25 gallon (0.9 l) sachets and 1.1 gallon (4.2 l) pails. Coverage rate of 19 square feet (1.76 square meters) per 0.25 gallon (0.9 l) sachet.
5. **LIQUISEAL Spiral Mixing Agitator** – A 3" (7.62 cm) long steel spiral agitator with a 1/2" (1.27 cm) hex drive for use with handheld drills and mixers. Used to properly mix resin.
6. **LIQUISEAL Surfacing Sand** – Kiln-dried #00 - #35 graded sand suitable for broadcasting into LIQUISEAL Liquid Flashing Concrete & Masonry Primers for use in substrate preparation. Used with Concrete & Masonry Primer to promote proper adhesion and mechanical bond. Packaged in 50lb (22.6 kg) bags.

B. Warranty

Projects meeting the conditions below can be eligible for a maximum 20 year System Warranty with wind speed coverage up to 90 mph peak gusts. Projects requiring extended wind speed coverage warranty must be submitted to Versico for review prior to installation.

C. Precautions

1. Always store in a cool, dry location between 35 – 80°F (1.7– 27°C). Do not store in direct sunlight. Approximate shelf life is 12 months with proper storage. Best practice is to store material at 65 – 70°F (18 – 21°C) for 24 hours before use.
2. Do not install if ambient temperature is below 40°F (4°C) or above 90°F (32°C).
3. Do not break down work packs into smaller quantities; mix the entire work pack.
4. Prepare surfaces and pre-cut all fleece before mixing resin. Pot life will be shorter as ambient temperature rises.
5. Use appropriate safety glasses and protect hands and wrists by wearing gloves.

D. Installation

1. **Surface Preparation:** Prepare all substrates by removing any irregularities and any loose or foreign material such as dirt, water, grease, oil, lacquers, or release agents. Prepare membrane by sanding with 60-grit sandpaper.

2. Metal Primer Application:

- a. All metal surfaces must be prepared using a grinder. Do not use a wire brush. Ensure that all metal surfaces are ground down to expose bare metal.
- b. Use membrane cleaner to wipe clean.
- c. Remove bag from the aluminum packaging. Knead cream-colored resin (Component A) thoroughly until a uniform color is achieved.
- d. Pull away the rubber cord separating the two components so that Components A and B can be mixed together. Knead the bag quickly and thoroughly for approximately 1 minute so that a homogenous primer is formed. The primer should be a uniform color, with no light or dark streaks present.
- e. After the primer is mixed, cut off one corner of the bag and pour all primer into a clean, new mixing pail. Working quickly, apply approximately 25 square feet (2.3 square meters) per 0.25 gallon (0.9 l) sachet. The primer should be rolled or brushed evenly onto the surface in a cross-directional method to fully cover the substrate in one application. Allow to set for approximately 3 hours or until fully cured prior to application of the LIQUISEAL Liquid Flashing Resin.

Note: LIQUISEAL Liquid Flashing Resin must be applied when the primer is completely dry and without tack. Do not apply LIQUISEAL Liquid Flashing Resin to tacky or wet primer.

3. Concrete & Masonry Primer Application:

- a. Prepare all substrates by removing any irregularities and any loose or foreign materials such as dirt, water, grease, oil, lacquers, or release agents using a grinder. All concrete substrates should be dry and fully cured.
- b. Remove bag from the aluminum packaging. Knead translucent yellow resin (Component A) thoroughly until a uniform color is achieved.
- c. Pull away the rubber cord separating the two components so that Components A and B can be mixed together. Knead the bag quickly and thoroughly for approximately 1 minute so that a homogenous primer is formed. The primer should be a uniform color, with no light or dark streaks present.

- d. After the primer is mixed, cut off one corner of the bag and pour all primer into a clean, new mixing pail. Working quickly, apply at a rate of approximately 19 square feet (1.76 square meters) per 0.25 gallon (0.9 l) sachet. The primer should be rolled or brushed evenly onto the surface in a cross directional method to fully cover the substrate in one application.
- e. After applying the primer, immediately broadcast LIQUISEAL Liquid Flashing Concrete & Masonry Preparation Sand into the uncured primer at the approximate rate of 50 lbs (22.6 kg) per 100 square feet (9.29 square meters). Allow to set for approximately 4 hours or until fully cured prior to application of the LIQUISEAL Liquid Flashing Resin.
- f. In warm climates, higher contents of moisture or vapor within a concrete substrate may cause pinholing of the primer due to vapor drive. Applying primer later in the day when temperatures are lower can improve this condition.

Note: LIQUISEAL Liquid Flashing Resin must be applied when the primer is completely dry and without tack. Do not apply LIQUISEAL Liquid Flashing Resin to tacky or wet primer.

4. LIQUISEAL Liquid Flashing Application:

- a. Apply the appropriate primer to membrane and allow to flash off. Apply appropriate primer to all other surfaces to which flashing will be applied.
- b. Cut and prepare all reinforcing fleece before mixing resin.
 - i. For LIQUISEAL Resin in 1.03 gallon (3.9 l) Pail Packaging
 - 1. Mix resin (Component A) with a clean spiral agitator until the liquid is a uniform white or gray color.
 - 2. Add hardener (Component B) to Component A and mix with a spiral agitator for 2 minutes or until both liquids are thoroughly blended.
 - ii. For LIQUISEAL in 0.25 gallon (0.9 l) Sachet Packaging
 - 1. Remove bag from the aluminum packaging.
 - 2. Knead white or gray resin (Component A) thoroughly until a uniform color is achieved.
 - 3. Pull away the rubber cord separating the two components so that Components A and B can be mixed together. Knead the bag quickly and thoroughly for approximately 1 minute so that a homogenous resin is formed. The resin should be a uniform color, with no light or dark streaks present.
 - 4. After the resin is mixed, cut off one corner of the bag and pour entire sachet of resin into a clean, new mixing pail. Working quickly, apply at a rate of approximately 13.6 square feet (1.3 square meter) per gallon (3.8 l).
- c. Using a nap roller or brush, apply two-thirds of the resin evenly onto the substrate using even strokes.
- d. Roll the LIQUISEAL Liquid Flashing Fleece directly into the LIQUISEAL Liquid Flashing Resin, ensuring that the SMOOTH SIDE IS FACING UP (natural unrolling procedure) and avoiding folds, wrinkles, and air pockets.
- e. Apply the remaining one-third of the resin and use the roller or brush to work the resin into the fleece, saturating from the bottom up. All areas of the fleece should be completely saturated with resin.
- f. Repeat steps 'b through e' again for subsequent layers of resin and flashing as needed for detailing.

E. Associated Installation Details

Inspection, Cleaning & Substrate Preparation (Page 1 of 2)	Attachment 1
Inspection, Cleaning & Substrate Preparation (Page 2 of 2)	Attachment 1
Application of LiquiSeal Primer & Resin	Attachment 2
Sheet Metal Drip Edge or Gravel Stop Flashing	LF-1.1
Single and Multiple Pipe Penetrations (Page 1 of 2)	LF-8.1
Single and Multiple Pipe Penetrations (page 2 of 2)	LF-8.1
EPDM Membrane Tie-in with Existing Roof over Steel Deck	LF-13.1 TPO
PVC Membrane Tie-in with Existing Roof over Steel Deck (Page 1 of 2)	LF-13.2
TPO or PVC Membrane Tie-in with Existing Roof over Steel Deck (Page 2 of 2)	LF-13.2
Membrane Tie-in with Existing Roof over Concrete Deck	LF-13.3
Through-Wall Scupper	LF-18.1
Steel I-Beam Flashing (Page 1 of 2)	LF-30.1
Steel I-Beam Flashing (Page 2 of 2)	LF-30.1

Notes:

- The following tables provide recommendations for preparation and priming of substrates and should be used as a guideline for proper adhesion & performance.
- The primer application rate will vary and should be adjusted depending on the substrate. See Product Data Sheets, SDS, Guide Specifications and Details for complete information regarding the suitability, application and handling of products.

INSPECTION		EPDM	TPO	PVC / KEE HP	METAL SURFACES	MASONRY
A.1	Inspect insulation for wet conditions underneath the roof membrane. Remove & replace wet materials underneath to match in kind.	Y	Y	Y		
A.2	Ensure, membrane or roof assembly is properly secured.	Y	Y	Y		
A.3	Provide additional securement at the base of penetrations, tie-ins or angle changes per details.	Y	Y	Y		
A.4	Ensure, there is no standing water. Remove and dry the work area. Remove dust, debris and wipe the work surfaces clean. Masonry must be completely dry and sound.	Y	Y	Y	Y	Y
A.5	Verify structural integrity of metal objects. Check for broken welds or loose bolts. Verify the thickness of exposed metal after removal of finishes or rust for strength.				Y	
A.6	Ensure, there is no moisture present in the substrate.	Y	Y	Y	Y	Y
A.7	Within the work area, inspect the seams of existing membrane for proper seal.	Y	Y	Y		
A.8	Do not damage structural members, welds or remove any nuts/bolts unless approved by designer.				Y	
CLEANING & SUBSTRATE PREPARATION		EPDM	TPO	PVC / KEE HP	METAL SURFACES	MASONRY
B.1	Use 60 grit sandpaper to rough up the top surface of the membrane.	Y	Y	Y		
B.2	Use abrasive grinding wheel (a diamond cup wheel is suggested) to expose the bare metal (do not use wire brush). Expose metal around nuts & tighten as needed. Wipe the membrane cleaner.				Y	Y
B.3	Remove dust, clean the surfaces with broom & power blower.	Y	Y	Y	Y	Y
B.4	Wipe the surfaces with Carlisle Membrane Cleaner , (Standard or Low VOC)	Y	Y	Y	Y	
B.5	Use painter's tape to contain flashing resin. Tape shall be set 1/4" to 1/2" (1-1.5cm) beyond the fleece edges.	Y	Y	Y	Y	Y
EXISTING BITUMINUOUS ROOFING SUBSTRATES					CONCRETE & MASONRY PRIMER	
C.1	Modified Bitumen Smooth APP Surfaced.	Power wash to remove contaminants.			Y	
C.2	Modified Bitumen Smooth SBS Surfaced.					
C.3	Bituminous Roofing – Granular Surfaced.	Power wash to remove contaminants & loose granules				
C.4	Following bituminous substrates are not acceptable: Aluminum coating, flood coat & aggregate, coal tar pitch roofing – flood coat & aggregate, hot-melt bituminous waterproofing & ethylene-faced bituminous (bituthane) roofing.					

INSPECTION CLEANING & SUBSTRATE PREPARATION
(PAGE 1 OF 2)

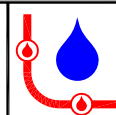

ATTACHMENT 1

For additional information, refer to Spec. Supplement

LIQUID FLASHING

METAL SUBSTRATES			METAL PRIMER
D.1	Bare aluminum, lead, copper & zinc.	Grind to remove corrosion, then use membrane cleaner to wipe and clean.	Ⓚ
D.2	Bare steel, galvanized steel.		
D.3	Black pipe, cast iron.	Grind to remove corrosion and coating. Then use membrane cleaner to wipe and clean.	Ⓚ
D.4	Stainless steel.	Grind to achieve rough surface. Then use membrane cleaner to wipe and clean.	Ⓚ
D.5	Kynar finish, ceramic coated, and painted metal.	Grind to remove coating. Then use membrane cleaner to wipe and clean.	Ⓚ
CEMENTITIOUS AND MASONRY SUBSTRATES			MASONRY PRIMER
E.1	Structural & or lightweight structural concrete.	Scarify, shot blast or grind to remove laitance and open up pores	Ⓚ
E.2	Granite, Marble.	Scarify, shot blast, grind to remove polished surface and open up pores	Ⓚ
E.3	Clay brick, terra cotta, tile.	Scarify, shot blast, grind to remove glazed surface and open up pores.	Ⓚ
E.4	Sandstone, limestone, synthetic stone.	Scarify, shot blast, grind to open up pores	Ⓚ
E.5	Porous/air-entrained concrete, concrete masonry block.		
E.6	Repair & leveling mortars.		
GLASS & PLASTIC SUBSTRATES			METAL PRIMER
F.1	Glass.	Sand to abrade surface. Then use membrane cleaner to wipe and clean.	Ⓚ
F.2	Acrylic.		
F.3	Fiberglass.		
F.4	ABS, PVC – Rigid.		

Note: Contact Carlisle SynTec for substrate not listed in these tables.

CAUTION:

All substrates must be prepared as necessary prior to the application of primers. Surfaces must be free from irregularities, loose, unsound or foreign materials such as rust, dirt, ice, snow, water, grease, oil, release agents, paint, lacquers, coatings, or any other conditions that would be detrimental to adhesion of the primer and resin.

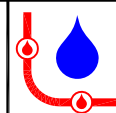

LIQUISEAL PRIMER & RESIN APPLICATION		EPDM	TPO	PVC / KEE / HP	METAL SURFACES	MASONRY
G.1	Ensure all surfaces are ready for application of primer prior to mixing, due to limited pot life.	Y	Y		Y	Y
G.2	Mix primer thoroughly, per specifications.	Y	Y		Y	Y
G.3	Apply LIQUISEAL Metal Primer per specifications.	Y			Y	
G.4	Masonry: Apply LIQUISEAL Concrete & Masonry Primer and surfacing sand per specifications.					Y
G.5	Wait for primer to cure per written instructions.	Y			Y	Y
G.6	Apply Low VOC Primer and allow to flash off completely.		Y			
G.7	Cut & dry-fit all fleece prior to mixing resin. Ensure, the fleece is set back from painter's tape, per B.5 .	Y	Y	Y	Y	Y
G.8	Mix LIQUISEAL Flashing Resin thoroughly (with spiral agitator if in pail).	Y	Y	Y	Y	Y
G.9	Apply a base layer of LIQUISEAL Flashing Resin ensuring generous coverage of entire substrate.	Y	Y	Y	Y	Y
G.10	Immediately press LIQUISEAL Flashing Fleece into the applied LIQUISEAL Flashing Resin , taking care at corners and crevices.	Y	Y	Y	Y	Y
G.11	Apply a 2nd (top coat) of LIQUISEAL Flashing Resin ensuring the fleece is completely saturated per published coverage rate.	Y	Y	Y	Y	Y

APPLICATION OF LIQUISEAL PRIMER & RESIN

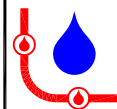

ATTACHMENT 2

For additional information, refer to Spec. Supplement

LIQUID FLASHING

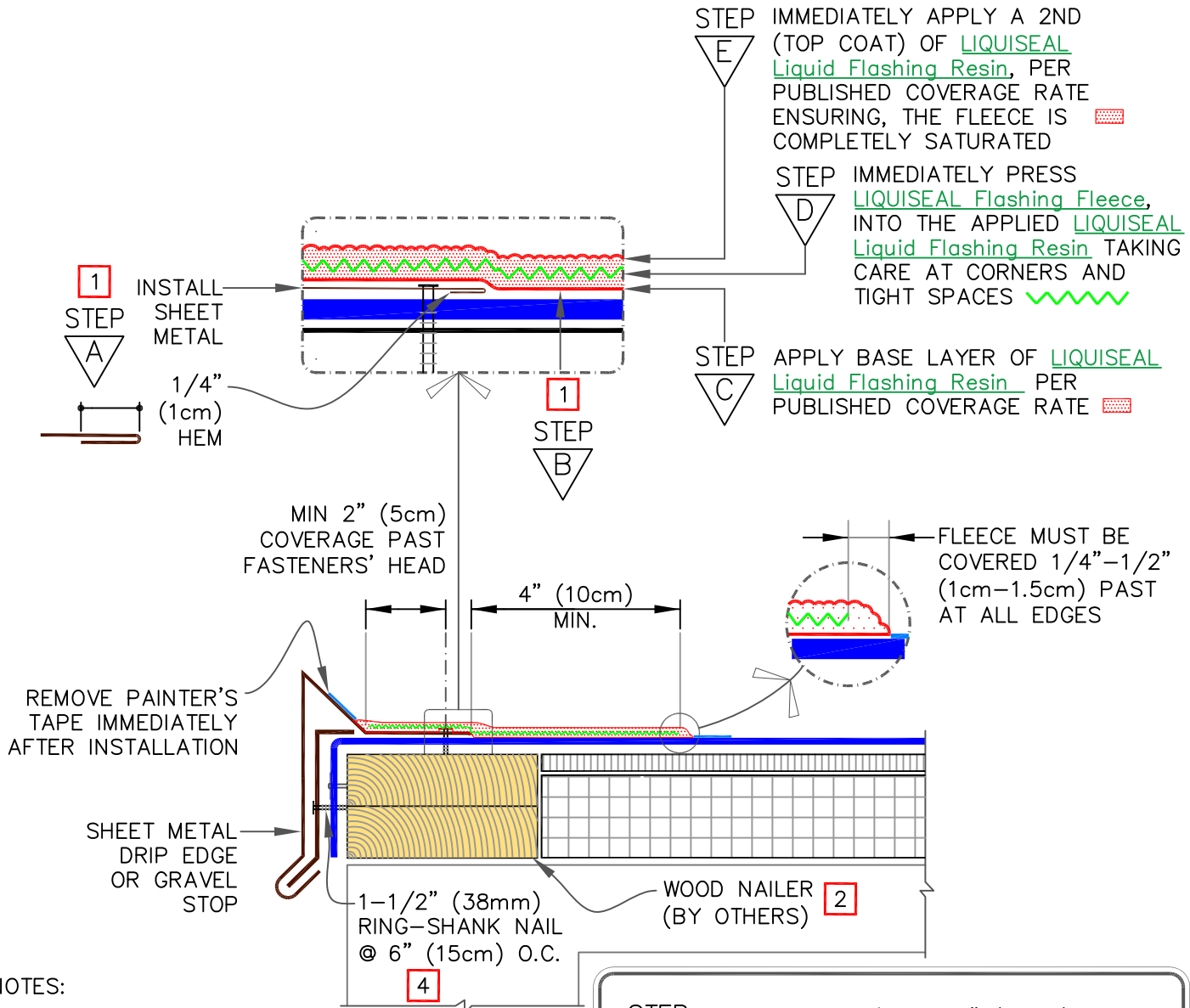

NOTES:

1. REFER TO TABLES ON SHEETS **ATTACHMENT 1-2** FOR DETAILED INSPECTION, CLEANING AND PRIMING FOR DIFFERENT MATERIALS WITHIN THE FLASHING AREAS.
2. WOOD NAILER MUST EXTEND PAST TOTAL WIDTH OF SHEET METAL FLANGE.
3. SAME DETAIL APPLIES AT THE TOP OF PARAPET WALL, WHERE FULL COPING IS NOT USED.
4. FASTENERS MUST BE SECURED INTO STRUCTURAL MEMBERS, E.G., CONCRETE, SOLID MASONRY OR WOOD BLOCKING.
5. DETAIL NOT FOR USE ON WARRANTY PROJECTS EXCEEDING 20-YEARS. UNLESS OTHERWISE SPECIFIED.

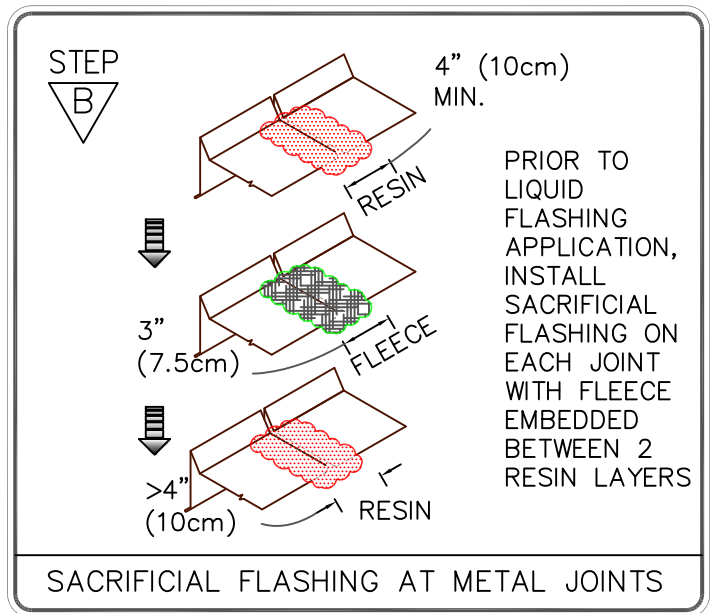

<p>— ROOF MEMBRANE — LIQUISEAL Flashing Fleece — LIQUISEAL Liquid Flashing Resin 0 — SEE NOTE(S)</p>	<p>SHEET METAL DRIP EDGE OR GRAVEL STOP FLASHING</p> <p>For additional information, refer to Specifications</p>		<p>DETAIL NO. LF-1.1 LIQUID FLASHING</p>
---	---	--	--

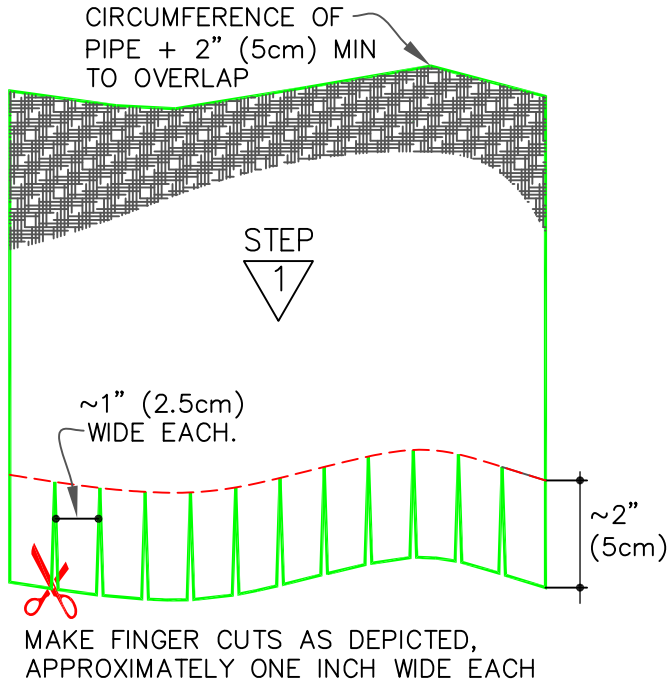

APPLY BASE COAT OF LIQUISEAL Liquid Flashing Resin PER PUBLISHED COVERAGE RATE

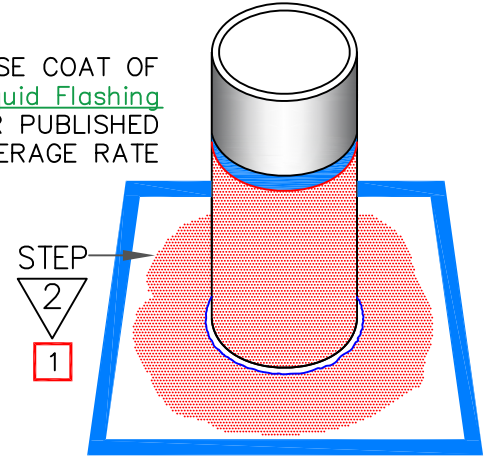

APPLY BASE COAT OF LIQUISEAL Liquid Flashing Resin ON HORIZONTAL SURFACES. IMMEDIATELY PRESS FLEECE INTO RESIN AND OVERLAP LIQUISEAL Flashing Fleece, MIN. 2" (5cm)

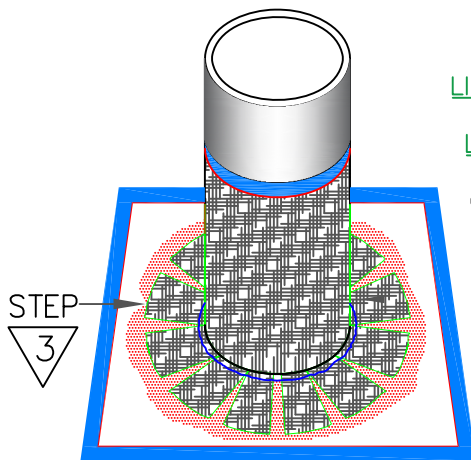

IMMEDIATELY PRESS LIQUISEAL Flashing Fleece INTO THE APPLIED LIQUISEAL Liquid Flashing Resin. APPLY SECOND COAT OF RESIN. ENSURE ALL ENDS OF FINGERS ARE PROPERLY EMBEDDED.

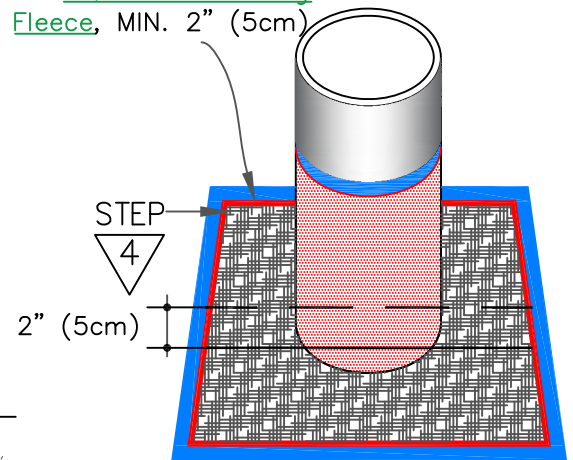

FLEECE MUST BE COVERED 1/4" - 1/2" (1cm - 1.5cm) PAST ALL EDGES

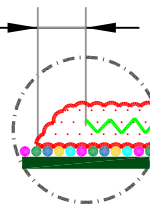

APPLY A TOP COAT OF LIQUISEAL Liquid Flashing Resin, ENSURING THE FLEECE IS COMPLETELY SATURATED PER PUBLISHED COVERAGE RATE AND APPLY 1/4" - 1/2" (1cm - 1.5cm) BEYOND THE FLEECE EDGES

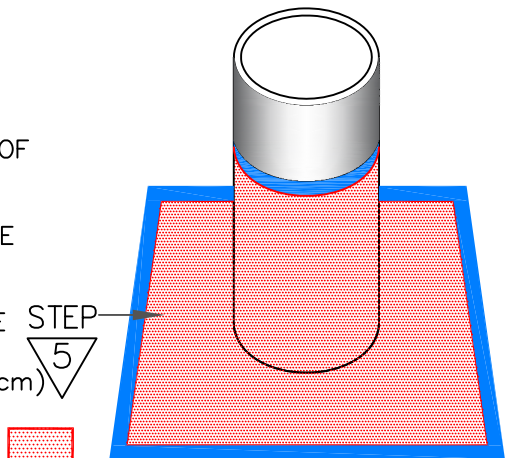

NOTES:

1. FOR MULTIPLE PIPE PENETRATIONS SEE STEP ZERO ON SHEET LF-8.1 (PAGE 2 OF 2) AND FOLLOW REST OF THE STEPS AS SHOWN FOR SINGLE PIPE FLASHING.
2. REFER TO TABLES ON SHEETS ATTACHMENT 1-2 FOR DETAILED INSPECTION, CLEANING AND PRIMING FOR DIFFERENT MATERIALS WITHIN THE FLASHING AREAS.
3. SEE PAGE 2 OF 2 FOR ADDITIONAL NOTES.

	<p>ROOF MEMBRANE</p> <p>LIQUISEAL Flashing Fleece</p> <p>LIQUISEAL Liquid Flashing Resin</p> <p>SEE NOTE(S)</p>	<p>SINGLE OR MULTIPLE PIPE PENETRATIONS (PAGE 1 OF 2)</p> <p>For additional information, refer to Specifications</p>		<p>DETAIL NO.</p> <p>LF-8.1</p> <p>LIQUID FLASHING</p>
--	---	--	--	--

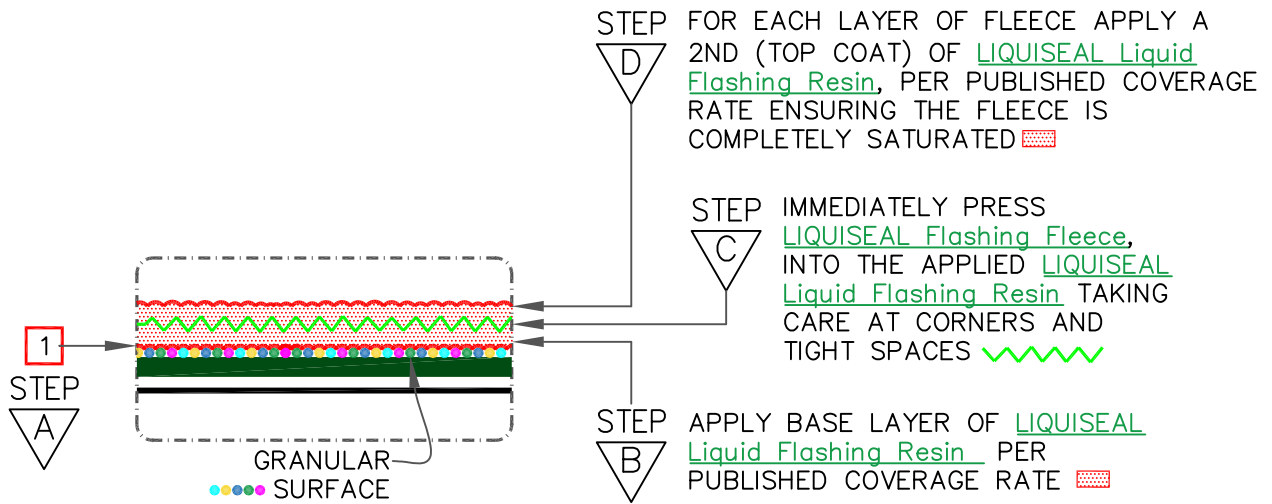

SEAM FASTENING PLATES & FASTENERS

DIMENSIONS	cm	
(A) 6"	15	T0
12"	30	
(B) 12"	30	MAX.

4 FASTENERS REQUIRED MIN.

PLAN VIEW

PIPE OUTSIDE DIAMETER < 6" (15cm)

PIPE OUTSIDE DIAMETER > 6" (15cm)

TABLE FOR FASTENER REQUIREMENTS ON MECHANICALLY FASTENED SYSTEMS. REFER TO CARLISLE TYPICAL PENETRATION DETAILS FOR FLASHING OVER FASTENER HEADS.

NOTES CONTINUE FROM [LF-8.1 \(PAGE 1 OF 2\)](#)

- WHEN THERE IS ENOUGH CLEARANCE BETWEEN MULTIPLE PENETRATIONS, INSTALL LIQUID FLASHING USING THIS DETAIL.
- WHEN INSTALLATION OF LIQUID FLASHING IS NOT FEASIBLE FOR MULTIPLE PIPE PENETRATIONS, THEN USE APPLICABLE STANDARD ROOF MEMBRANE DETAIL (U-16) FOR FIELD MEMBRANE TYPE.
- DETAIL NOT FOR USE ON WARRANTY PROJECTS EXCEEDING 20-YEARS. UNLESS OTHERWISE SPECIFIED.

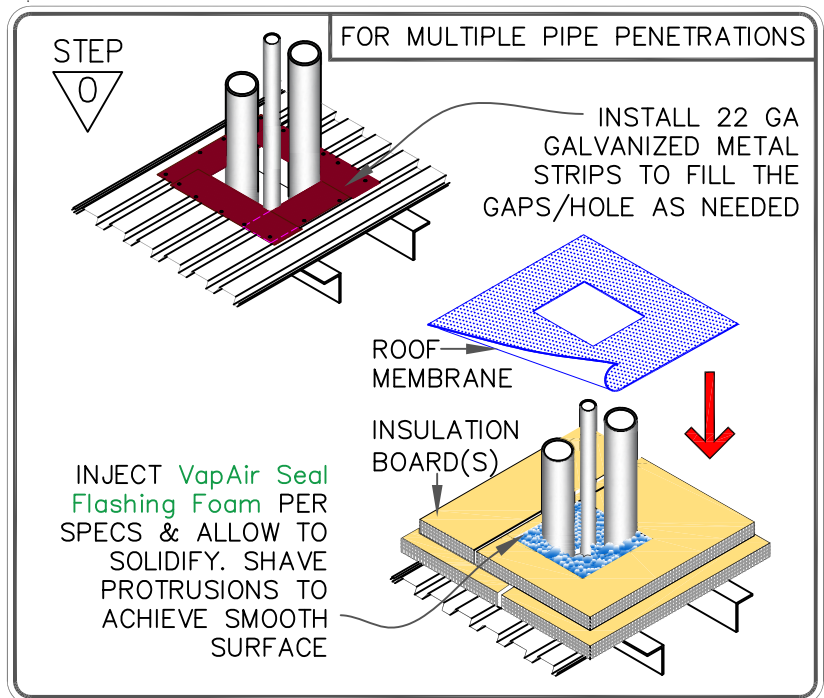

	<p>ROOF MEMBRANE</p> <p>LIQUISEAL Flashing Fleece</p> <p>LIQUISEAL Liquid Flashing Resin</p> <p>SEE NOTE(S)</p>	<p>SINGLE OR MULTIPLE PIPE PENETRATIONS (PAGE 2 OF 2)</p> <p>For additional information, refer to Specifications</p>		<p>DETAIL NO.</p> <p>LF-8.1</p>
<p>LIQUID FLASHING</p>				

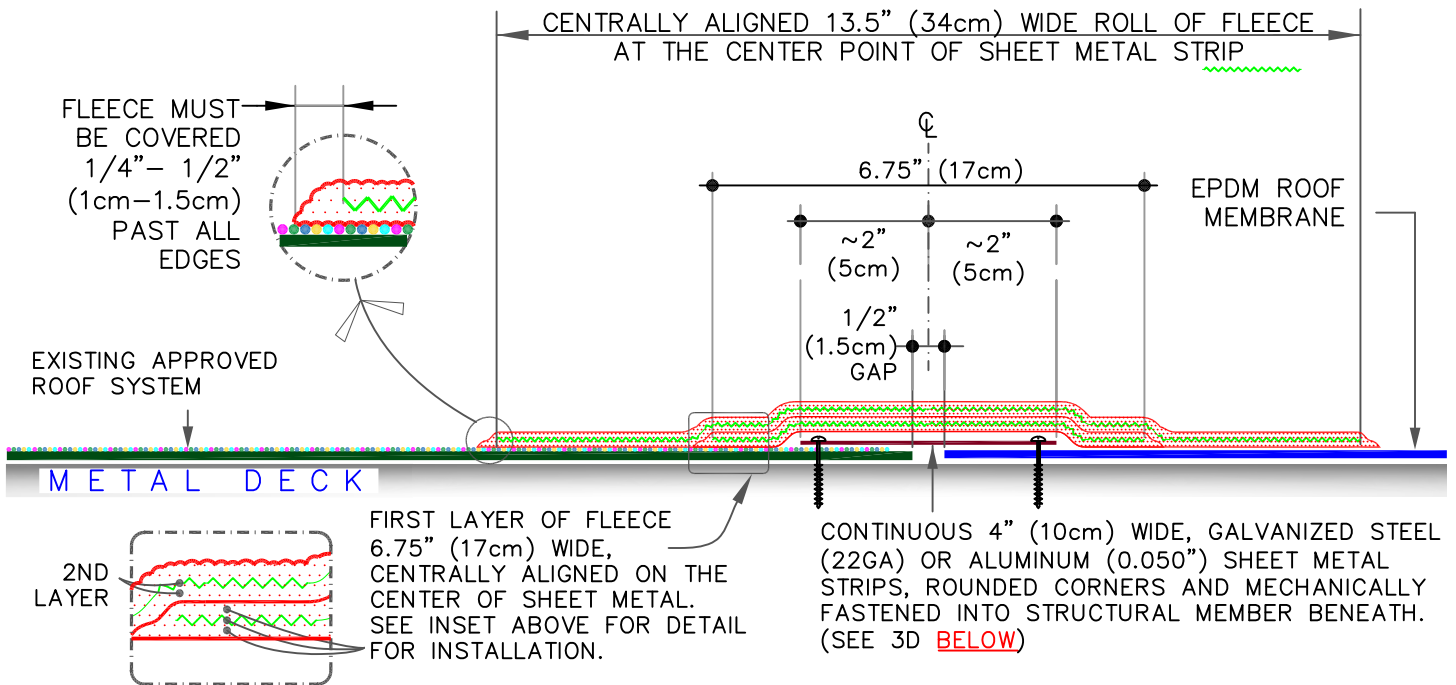
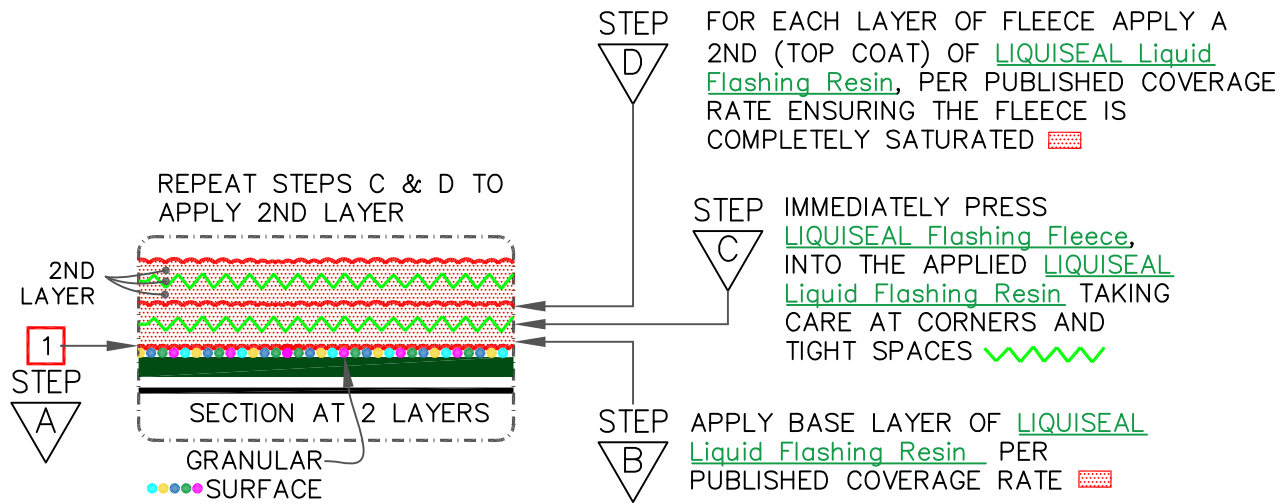

NOTES:

1. REFER TO **TABLES ON SHEETS ATTACHMENT 1-2** FOR DETAILED INSPECTION, CLEANING AND PRIMING FOR DIFFERENT MATERIALS WITHIN THE FLASHING AREAS.
2. IF FLUTES ARE PERPENDICULAR DRILL A 3/8" (1cm) WEEP HOLE IN THE BOTTOM FLUTES OF THE STEEL DECK ALONG THE TIE IN.
3. DETAIL NOT FOR USE ON WARRANTY PROJECTS EXCEEDING 20-YEARS. UNLESS OTHERWISE SPECIFIED.

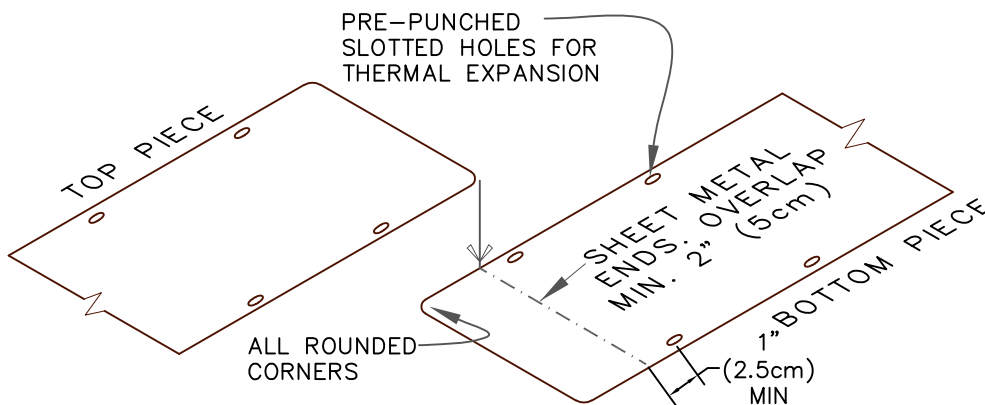

	<p>EPDM MEMBRANE TIE-IN WITH EXISTING ROOF OVER STEEL DECK</p> <p>For additional information, refer to Specifications</p>	<p>DETAIL NO.</p> <p>LF-13.1</p> <p>LIQUID FLASHING</p>
--	---	---

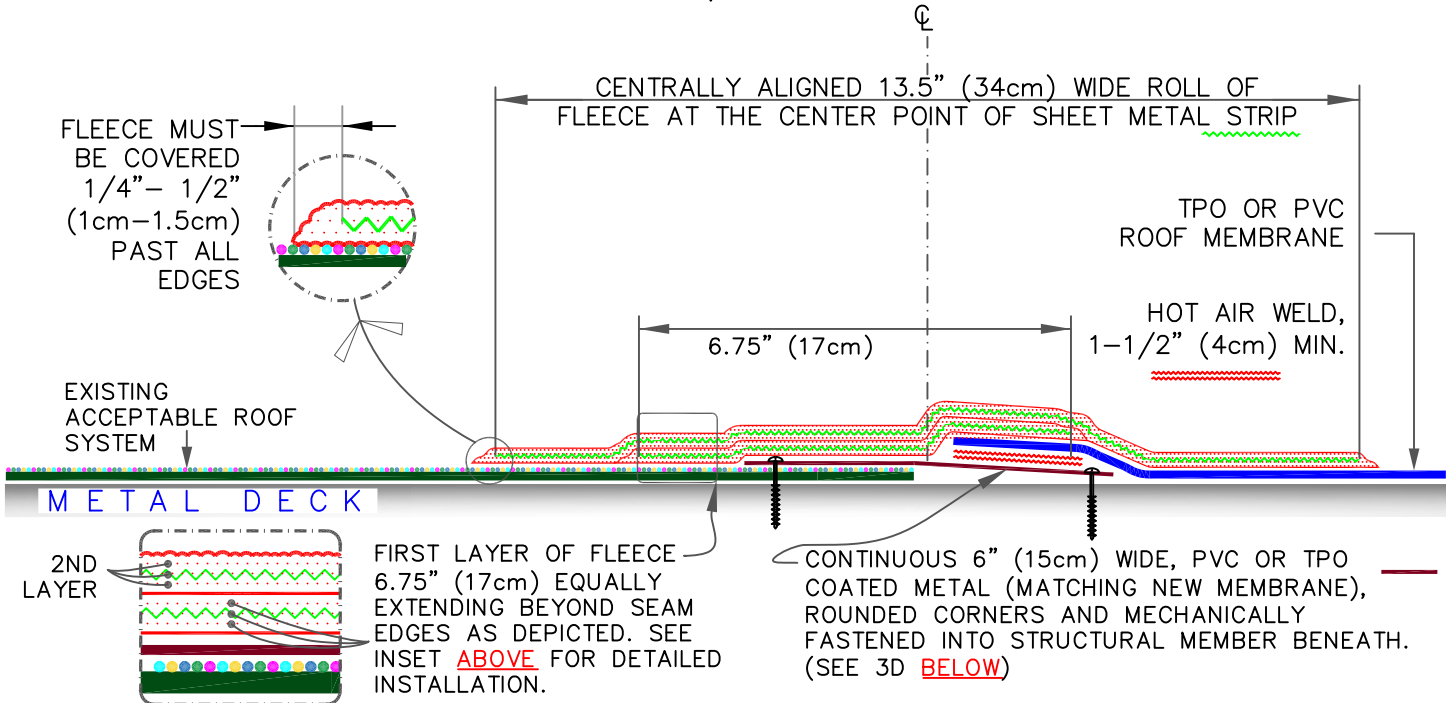
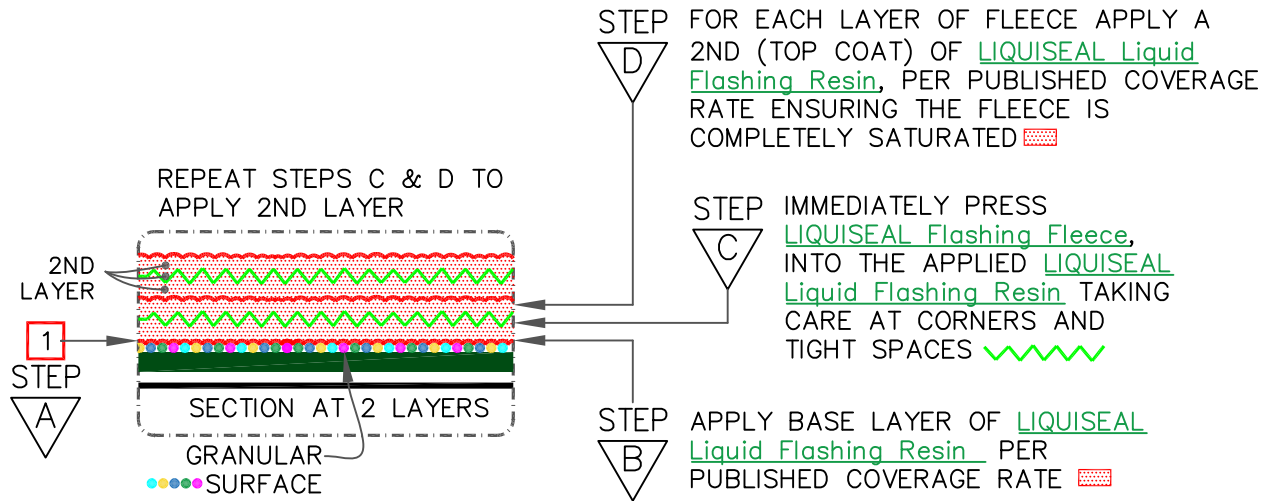

NOTES:

- REFER TO TABLES ON SHEETS ATTACHMENT 1-2 FOR DETAILED INSPECTION, CLEANING AND PRIMING FOR DIFFERENT MATERIALS WITHIN THE FLASHING AREAS.
- IF FLUTES ARE PERPENDICULAR DRILL A 3/8" (1cm) WEEP HOLE IN THE BOTTOM FLUTES OF THE STEEL DECK ALONG THE TIE IN.
- DETAIL NOT FOR USE ON WARRANTY PROJECTS EXCEEDING 20-YEARS UNLESS OTHERWISE SPECIFIED.

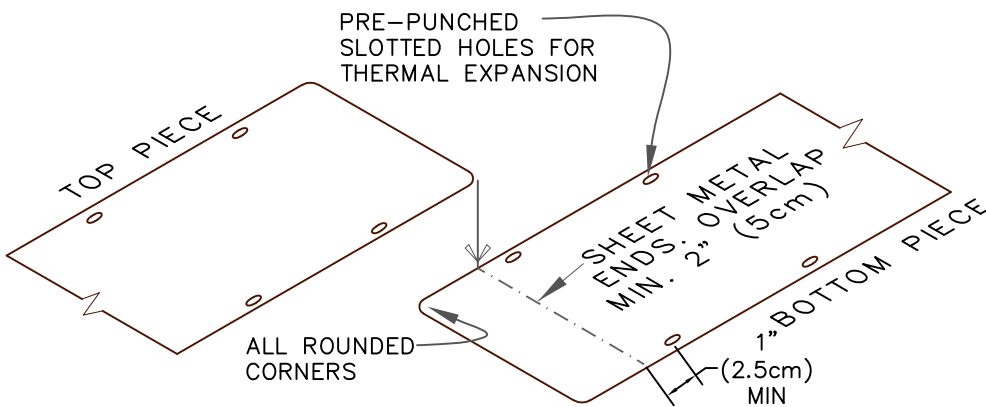

<p>ROOF MEMBRANE</p> <p>LIQUISEAL Flashing Fleece</p> <p>LIQUISEAL Liquid Flashing Resin</p> <p>0 SEE NOTE(S)</p>	<p>TPO OR PVC MEMBRANE TIE-IN WITH EXISTING ROOF OVER STEEL DECK (PAGE 1 OF 2)</p> <p>For additional information, refer to Specifications</p>		<p>DETAIL NO.</p> <p>LF-13.2</p> <p>LIQUID FLASHING</p>
---	---	--	---



INSTALL COATED SHEET METAL STRIPS WITH THREADED FASTENERS. REFER TO TABLES ON SHEETS [ATTACHMENT 1-2](#) FOR DETAILED INSPECTION, CLEANING AND PRIMING FOR DIFFERENT MATERIALS WITHIN THE FLASHING AREAS.



PROPERLY CLEAN WITH MEMBRANE CLEANER PRIOR TO WELDING.

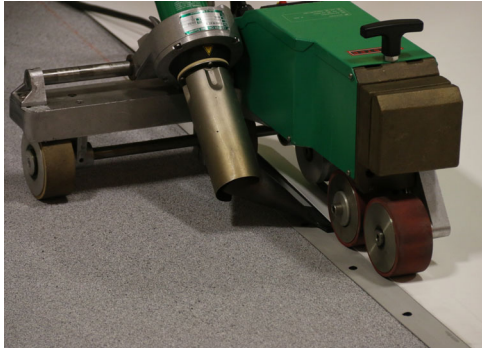

WELD TPO OR PVC MEMBRANE TO COATED METAL STRIP.



USE SAND PAPER GRIT # 60 TO ABRASE THE AREAS TO WHICH THE LIQUISEAL LIQUID FLASHING RESIN WILL BE APPLIED.



THOROUGHLY CLEAN THE TIE-IN AREA.

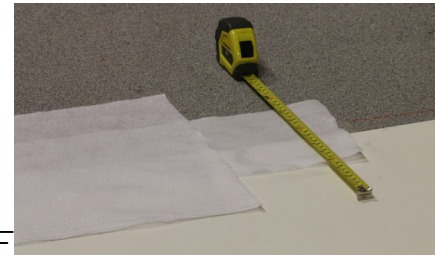

CUT TWO PIECES OF [LIQUISEAL Flashing Fleece](#), (FOR DIMENSIONS SEE [LF-13.2A](#)).

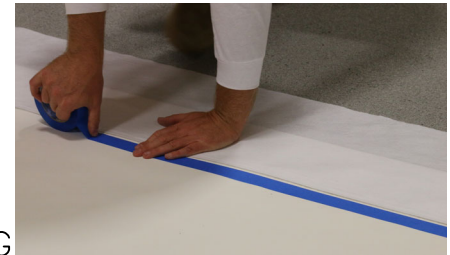

APPLY PAINTER'S TAPE ALONG TIE-IN EDGE.



THOROUGHLY MIX THE RESIN, PER PUBLISHED INSTRUCTIONS.



INSTALL BOTH LAYERS OF PRE-CUT [LIQUISEAL Flashing Fleece](#), EMBEDDED IN RESIN (SEE [LF-13.2A](#)).

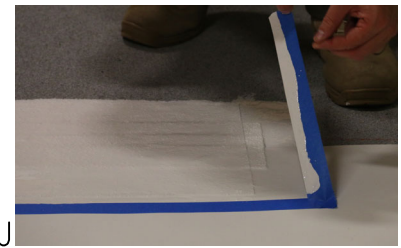

REMOVE TAPE IMMEDIATELY ENSURING THAT RESIN EXTENDS 1/4" - 1/2" BEYOND EDGE OF FLEECE.

<ul style="list-style-type: none"> — ROOF MEMBRANE — LIQUISEAL Flashing Fleece — LIQUISEAL Liquid Flashing Resin 0 — SEE NOTE(S) 	<p>TPO OR PVC MEMBRANE TIE-IN WITH EXISTING ROOF OVER STEEL DECK (PAGE 2 OF 2)</p> <p>For additional information, refer to Specifications</p>		<p>DETAIL NO.</p> <p style="font-size: 2em;">LF-13.2</p> <p>LIQUID FLASHING</p>
--	---	--	---

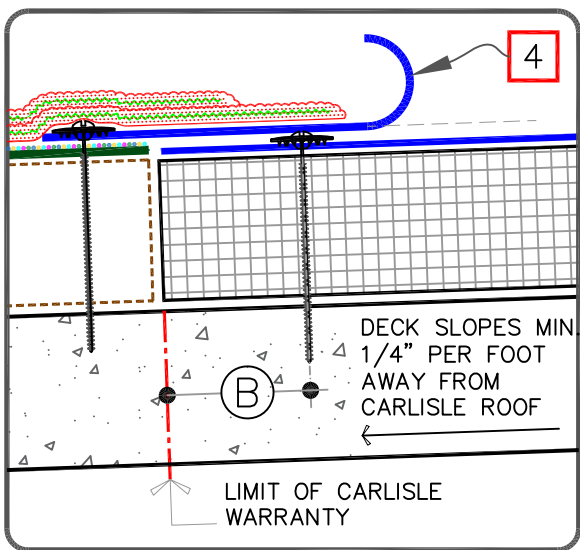
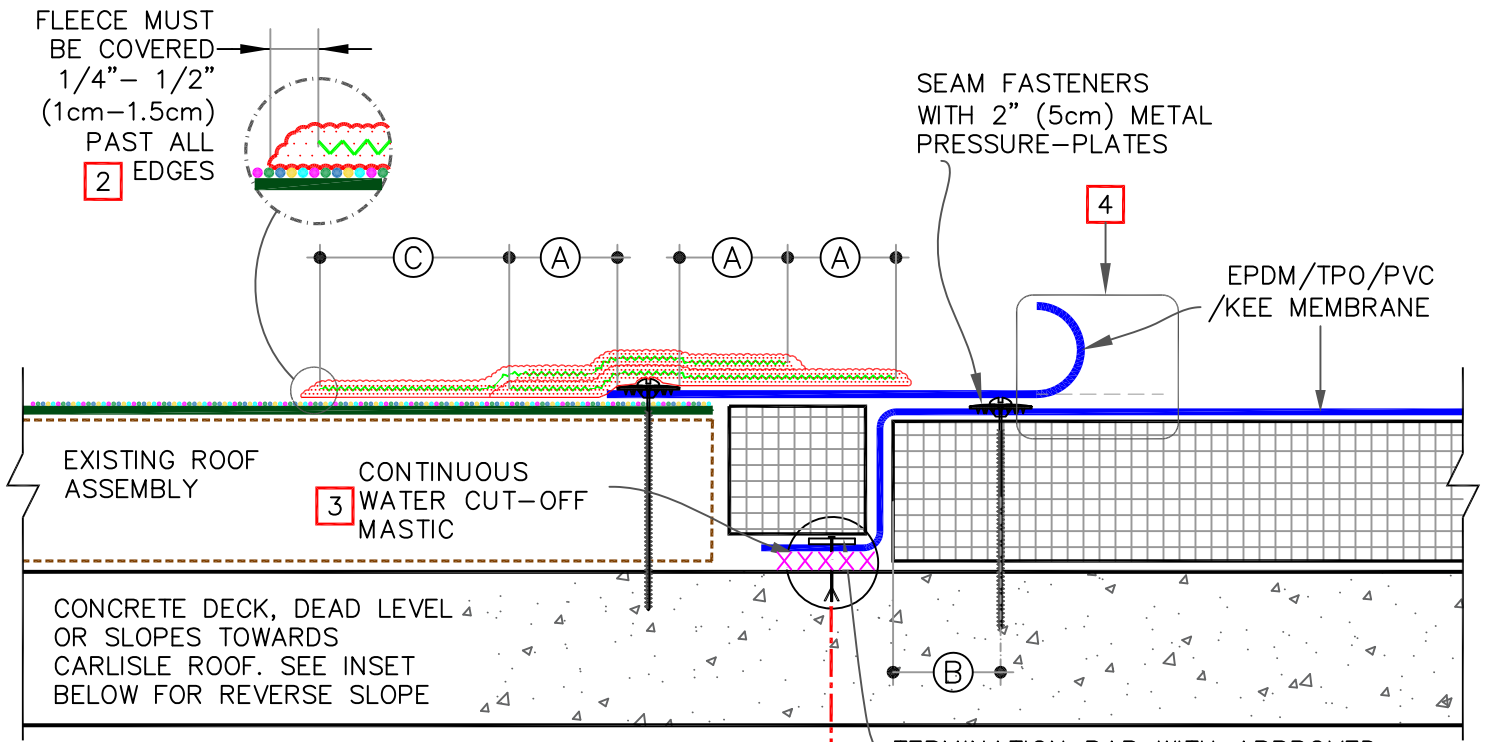

NOTES:

1. REFER TO TABLES ON [SHEETS ATTACHMENT 1-2](#) FOR DETAILED INSPECTION, CLEANING AND PRIMING FOR DIFFERENT MATERIALS WITHIN THE FLASHING AREAS.
2. DETAIL NOT FOR USE ON WARRANTY PROJECTS EXCEEDING 20-YEARS. UNLESS OTHERWISE SPECIFIED.
3. PROPERLY FILL THE JOINTS, VOIDS AND CRACKS ENSURING PROPER SEAL AGAINST WATER MIGRATION.
4. APPLICABLE SEAM DETAILS:
 - 4.1. EPDM: [U-2A & U-2A.1](#)
 - 4.2. TPO/PVC/KEE: [U-2A](#)

DIMENSIONS	cm		
(A)	3"	7.5	MIN.
(B)	2-3"	5-7.5	MIN.
(C)	AS REQUIRED DEPENDING ON SUBSTRATE, BUT MIN. 4" (10cm).		

	ROOF MEMBRANE
	LIQUISEAL Flashing Fleece
	LIQUISEAL Liquid Flashing Resin
	SEE NOTE(S)

MEMBRANE TIE-IN WITH EXISTING ROOF OVER CONCRETE DECK

For additional information, refer to Specifications

	DETAIL NO.
	LF-13.3
LIQUID FLASHING	

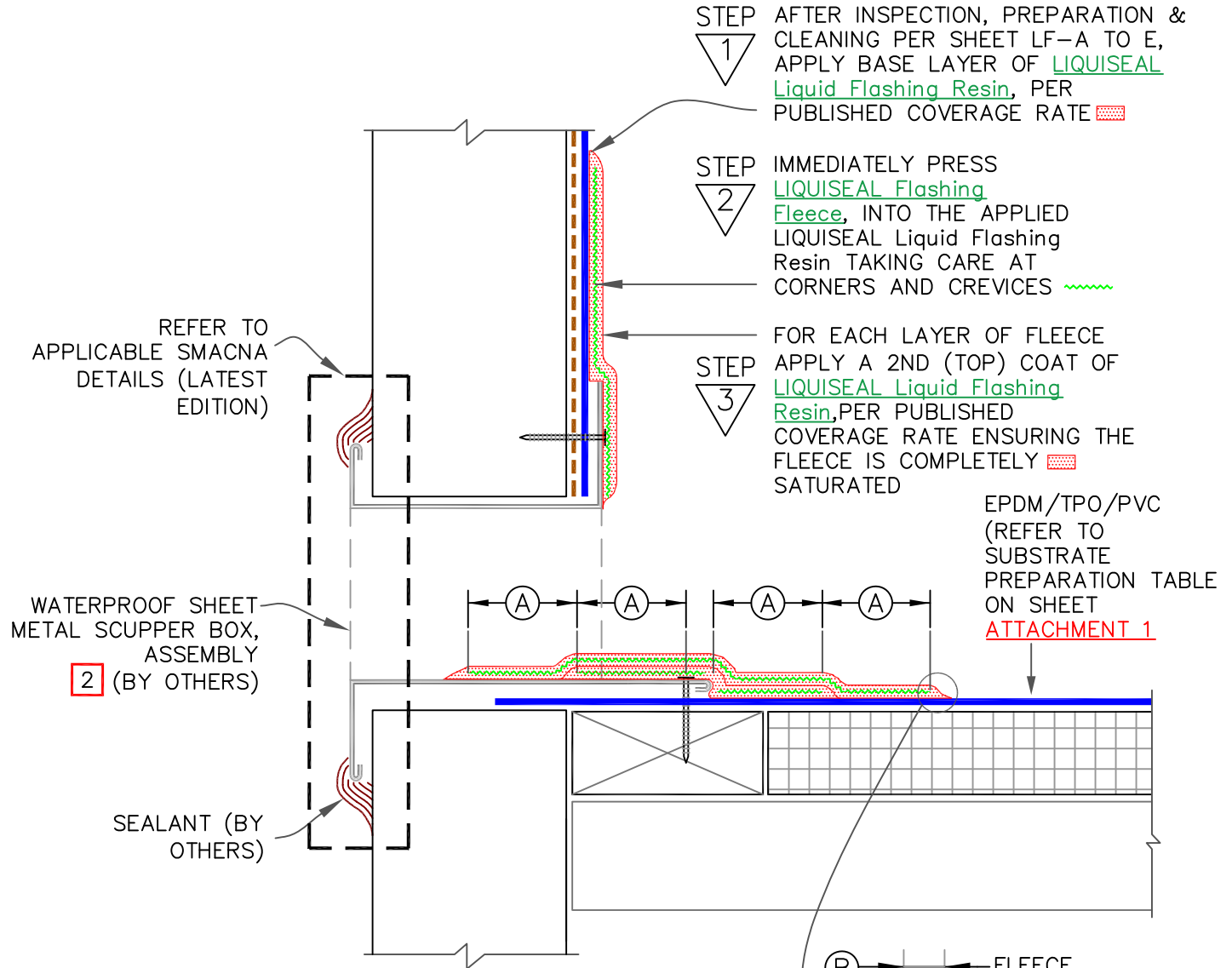

NOTES:

1. REFER TO TABLES ON SHEETS **ATTACHMENT 1-2** FOR DETAILED INSPECTION, CLEANING AND PRIMING FOR DIFFERENT MATERIALS WITHIN THE CONSTRUCTION AREA.
2. WOOD NAILER MUST EXTEND PAST TOTAL WIDTH OF SHEET METAL FLANGE.
3. MECHANICAL FASTENERS MUST BE SECURED INTO STRUCTURAL CONCRETE, SOLID MASONRY OR PRESSURE TREATED WOOD BLOCKING.
4. DETAIL NOT FOR USE ON WARRANTY PROJECTS EXCEEDING 20-YEARS. UNLESS OTHERWISE SPECIFIED.

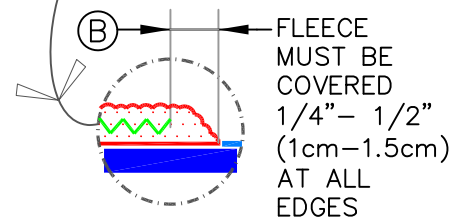

DIMENSIONS		cm	
(A)	3"	7.5	MIN.
(B)	1/4"	1	TO
	1/2"	1.5	

	<p>ROOF MEMBRANE</p> <p>LIQUISEAL Flashing Fleece</p> <p>LIQUISEAL Liquid Flashing Resin</p> <p>0 SEE NOTE(S)</p>	<p>THROUGH-WALL SCUPPER</p> <p>For additional information, refer to Specifications</p>		<p>DETAIL NO.</p> <p>LF-18.1</p> <p>LIQUID FLASHING</p>
--	--	--	--	---

INJECT **VapAir Seal Flashing Foam** PER SPECS & ALLOW TO SOLIDIFY. SHAVE PROTRUSIONS TO ACHIEVE SMOOTH SURFACE

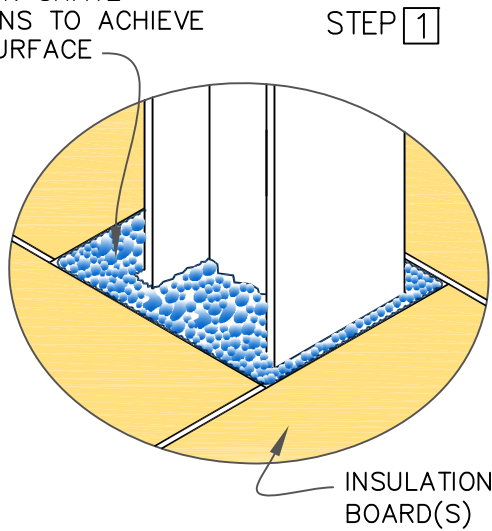

GRIND METAL WITH DIAMOND CUP GRINDING WHEEL

MEMBRANE SECURED WITH PLATES & FASTENERS PER SPECS

STEP 2



NOTE: ENSURE BODY OF PENETRATIONS & WELDS ARE COMPLETELY WATERPROOF.

DIAMOND CUP GRINDING WHEEL

STEP 3



USE SAND PAPER GRIT# 60 TO ABRAD THE MEMBRANE SURFACE.

STEP 4



REMOVE ALL GRINDING DUST, CLEAN METAL & MEMBRANE WITH CLEAN RAGS & MEMBRANE CLEANER.

STEP 5

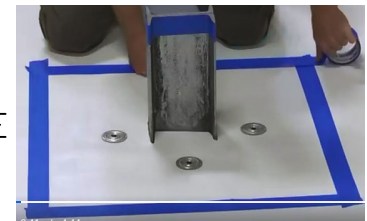

USE PAINTER'S TAPE AND TAPE OFF THE FLASHING AREA.

MEASURING, CUTTING & DRY FITTING TECHNIQUE

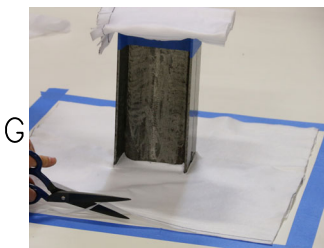
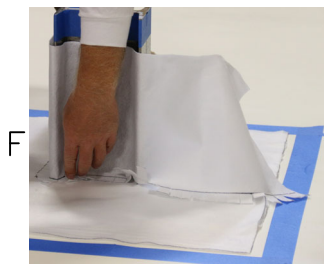

STEP 6

STEP 7

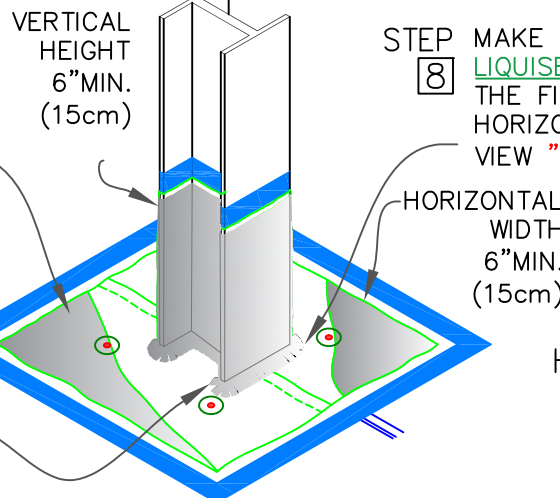

STEP 8 MAKE FINGER CUTS 2" (5cm) LONG IN **LIQUISEAL Flashing Fleece** AS SHOWN. THE FINGERS WILL REST ON THE HORIZONTAL SURFACE. SEE ENLARGED VIEW "1" ON [PAGE 2 OF 2](#).

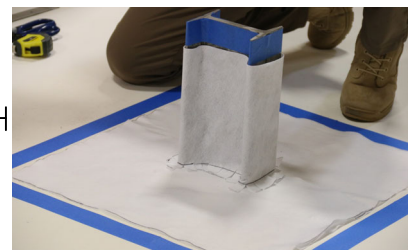

	ROOF MEMBRANE
	LIQUISEAL Flashing Fleece
	LIQUISEAL Liquid Flashing Resin
	SEE NOTE(S)

STEEL I-BEAM FLASHING
(PAGE 1 OF 2)

For additional information, refer to Specifications

	DETAIL NO.
	LF-30.1
LIQUID FLASHING	

SACHET MIXING AND PRIMER APPLICATION

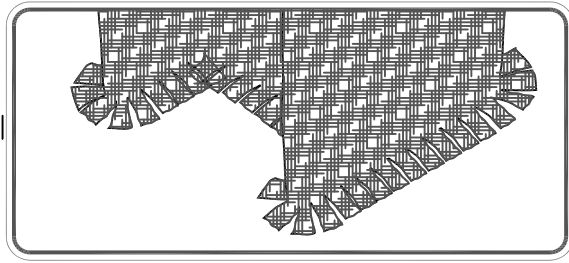

STEP 9

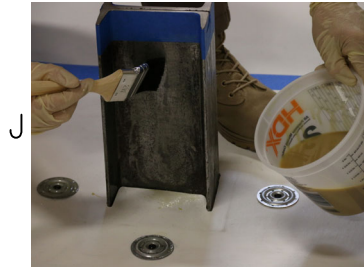

PRIME I-BEAM AND METAL PLATES. ENSURE AMBIENT AIR TEMPERATURE IS 40° & RISING. ALLOW PRIMER TO CURE UNTIL TACK-FREE.

STEP 10

APPLY 1ST COAT OF LIQUISEAL Liquid Flashing Resin & INSTALL LIQUISEAL Flashing Fleece ON VERTICAL SURFACES.

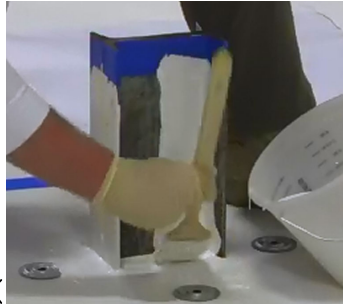

K

FLASHING FINAL INSTALLATION

STEP 11

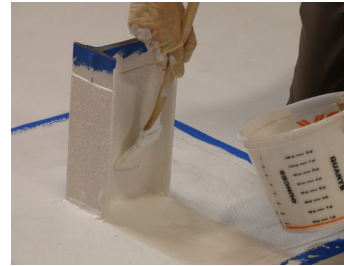

IMMEDIATELY APPLY A 2ND COAT OF LIQUISEAL Liquid Flashing Resin ENSURING THE FLEECE IS COMPLETELY SATURATED.

L

APPLY 1ST COAT OF RESIN AND INSTALL FLEECE ON HORIZONTAL SURFACES. IMMEDIATELY APPLY A 2ND COAT OF RESIN ENSURING FLEECE IS COMPLETELY SATURATED.

STEP 12

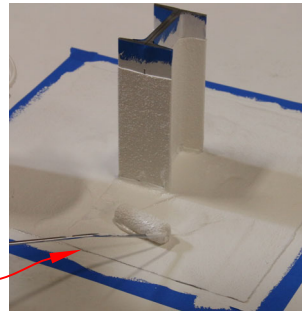

M

STEP 13

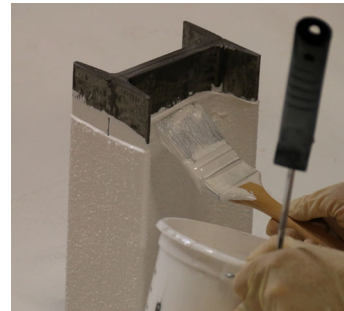

N

TOUCH UP AS NEEDED TO ENSURE ENTIRE FLEECE IS COMPLETELY SATURATED.

FLEECE MUST BE COVERED 1/4" - 1/2" (1cm - 1.5cm) BEYOND EDGES

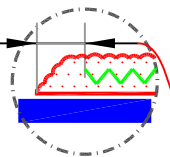

STEP 14

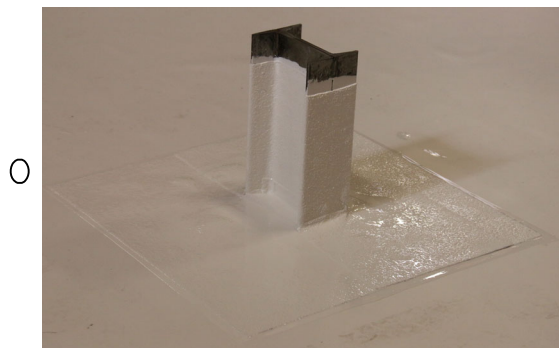

O

REMOVE TAPE IMMEDIATELY ENSURING THAT RESIN EXTENDS 1/4" - 1/2" (1cm - 1.5cm) BEYOND EDGE OF FLEECE

COMPLETED FLASHING

NOTE:
1. DETAIL NOT FOR USE ON WARRANTY PROJECTS EXCEEDING 20-YEARS. UNLESS OTHERWISE SPECIFIED.

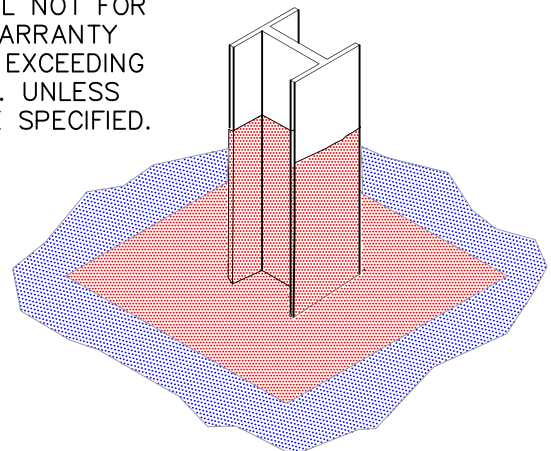

	<ul style="list-style-type: none"> — ROOF MEMBRANE — LIQUISEAL Flashing Fleece — LIQUISEAL Liquid Flashing Resin 0 — SEE NOTE(S) 	<p>STEEL I-BEAM FLASHING (PAGE 2 OF 2)</p> <p>For additional information, refer to Specifications</p>		<p>DETAIL NO. LF-30.1</p>
				<p>LIQUID FLASHING</p>

Copyright 2024 Versico

Versico and LIQUISEAL are Trademarks of Versico

This specification represents the applicable information available at the time of its publication. Owners, specifiers and Versico authorized roofing contractors should consult Versico or their Versico Independent Sales Representative for any information, which has subsequently been made available.

Review the appropriate Versico warranty for specific warranty coverage, terms, conditions and limitations.



SPECIFICATION

SUPPLEMENT

G-12-19

Application Procedures for Versico's VapAir Seal MD Air and Vapor Barrier

January 2024

The information contained in this supplement serves as a criteria for Specifiers and Authorized Contractors regarding the design and installation of Versico Roofing Systems and related products. Additional information essential for the design and installation of the Roof Systems mentioned herein are also included in the respective Specification for each Roof System and in the Design Reference Section of the Versico Technical Manual. Specifiers and Authorized Contractors are advised to reference all applicable sections.

A. General

1. **Versico VapAir Seal MD Air and Vapor Barrier** – a reinforced composite aluminum foil with self-adhesive SBS backing and removable poly release film. Used for direct application over metal decks. Available in rolls 42.5" wide by 131.23" long (460 square feet).
2. **Versico CAV-GRIP 3V Low-VOC Adhesive/Primer**: a low-VOC, methylene chloride-free adhesive that can be used for a variety of applications including: enhancing the bond between Versico's VapAir Seal MD and various substrates. Coverage rate is approximately 2,000-2,500 sq. ft. per 40 lb cylinder and 4,000-5,000 sq. ft. per 85 lb cylinder as a primer, in a single-sided application.
3. **CCW 702 Primer and 702LV Primer (Low VOC)** - A single component, solvent based, high-tack primer used to provide maximum adhesion between Versico 725TR Air and Vapor Barrier and an approved substrate. Applied by spray or long nap roller with a coverage rating ranging from approximately 300 to 350 square feet per gallon on smooth finishes (i.e., concrete) to 75 square feet per gallon on porous surfaces (i.e., Dens-Deck Prime gypsum board). Available in 5-gallon containers. CCW 702LV Primer contains less than 250g/L VOCs and meets South Coast Air Quality Management District (SCAQMD) and Leadership in Energy and Environmental Design (LEED) Requirements for Volatile Organic Compounds.
4. **CCW 702 WB** – a high-tack, water-based contact adhesive for promoting adhesion of Versico air/vapor barrier membranes and an approved substrate (i.e., concrete, Dens-Deck Prime and Securock). Applied by roller, brush or spray with an application rate of approximately 200 sq. ft. per gallon. Available in 5-gallon containers. CCW 702 WB Primer contains 57g/L VOCs and meets South Coast Air Quality Management District (SCAQMD) and Leadership in Energy and Environmental Design (LEED) Requirements for Volatile Organic Compounds.

B. Approved Substrates

VapAir Seal MD Air and Vapor Barrier is specifically designed for direct application to fluted steel decks. It may also be used in conjunction with either Versico's CAV-GRIP 3V on vertical wall surfaces, such as structural concrete, gypsum, Securock, DensDeck Prime and plywood substrates.

CAUTION: Use of standard DensDeck is not recommended due to excessive primer absorption. When the use of standard DensDeck is specified, two coats of Versico Primer will be required along with a trial test to verify adequate adhesion of the Versico's VapAir Seal MD Air and Vapor Barrier.

C. Limitations

1. Do not apply primer or vapor barrier to frozen substrates. Best results are obtained when temperatures are above 40°F (4°C).
2. Versico's VapAir Seal MD Air and Vapor Barrier may be installed in temperatures as low as 10°F (-12°C) based on the following criteria:
 - a. All materials (Vapor Barrier and Primer) must be stored in temperatures above 60°F (15°C) prior to installation.
 - b. For best results, CAV-GRIP 3V primer should be applied to the metal deck to ensure proper adhesion during the roofing installation. CAV-GRIP 3V primer will allow for the shortest flash off time (approximately 5 minutes). **Note: The propellant in CAV-GRIP 3V will revert back to a liquid when the cylinder temperature falls below 45°F (7°C). If this occurs, simply warm the cylinder up above 60°F (15°C) and the propellant will revert back to a gas.**
 - c. In temperatures below 40°F (4°C) priming the seams is recommended to ensure seam performance.
3. Do not apply primer or vapor barrier to damp or contaminated surfaces.
4. Versico's VapAir Seal MD Air and Vapor Barrier is not recommended for use over sealants containing coal tar or polysulfides. If these materials are present, they must be removed and the surfaces thoroughly cleaned.

D. Installation

1. **Surface Preparation:** The surface shall have a smooth finish and be free of voids, spalled areas, sharp protrusions, loose aggregate, laitance and form release agents. In the event of rain, concrete must be allowed to dry before primer is applied.
2. **Primer:** Non-metal surfaces to receive VapAir Seal MD must be clean and dry. Prime with CAV-GRIP 3V, CCW 702, 702LV or CCW WB Primer. Apply Primer by spray, brush or with a long nap roller at the applicable coverage rate noted above. At 75°F allow 702, 702LV and 702WB primer to dry 75 minutes minimum. Primer has a satisfactory cure when it will not transfer when touched. Prime only areas to be waterproofed the same day. At 75°F allow CAV-GRIP 3V primer to dry approximately 5 minutes minimum. Re-prime if area becomes dirty.
3. **Application:** Apply VapAir Seal MD Air and Vapor Barrier to the metal deck from low to high point, in a shingle fashion, so that laps will shed water. Overlap all edges at least 2-1/2". End laps shall be staggered. Place either a 6" wide section of 24 gauge sheet metal or a 6" wide section of VapAir Seal MD directly on the metal under each end lap, perpendicular to the end lap, to ensure a solid surface to roll the end lap together. Seams and end laps must be rolled with a 2" seam roller or stand-up seam roller. Place membrane carefully so as to avoid wrinkles and fish mouths. Immediately after installation, broom the sheet to ensure proper contact to the metal.
 - a. Apply a bead of lap seal should be applied at the interior of all T-Joint intersection. Please refer to applicable Versico Details.
4. **Repairs:** Following application, inspect VapAir Seal MD membrane for tears, punctures, fish mouths, air bubbles and voids due to misalignment at seams. Remove damaged membrane. Prime exposed substrate and allow primer to dry. Apply a new section of VapAir Seal MD Air and Vapor Barrier to primed substrate, extending onto adhered membrane, 6" on all sides. With a seam roller; roll VapAir Seal MD repair section to ensure a proper seal. Slit fish mouths and overlap the edges.

5. **Insulation Installation:** Ensure surface of VapAir Seal MD Air and Vapor Barrier is dry prior to installing insulation. Place insulation over the surface and mechanically fasten to the roof deck accordance with this Versico Specification.
6. **Installation at angle changes:** To ensure proper installation, the vertical wall must be clean of debris and residual asphalt. Prime the vertical surface ensuring the primer extends a minimum of 2" above where the VapAir Seal MD meets the vertical wall. After installing the VapAir Seal MD, use a seam roller on the vertical surface to ensure contact to the wall. There are two options for applying the MD to the vertical surface:
 - a. Option One: Apply the VapAir Seal MD up the vertical surface to the height of the insulation or a minimum of 2".
 - b. Option Two: Apply the VapAir Seal MD over the entire vertical surface ensuring the membrane extends over the top of the vertical surface and ties into exterior wall air barrier when applicable. Refer to applicable Versico details.

Note: When utilizing option 2, mechanically fastened 1/2" SecurShield HD board, 1/2" SecurShield HD Plus board, 1/2" DensDeck, 1/2" Securock or 1/2" plywood over the VapAir Seal MD surface to ensure a solid substrate to adhere the roofing membrane.
7. **Angle Change:** The VapAir Seal MD should be applied to the vertical surface at a 90° angle and be adhered to a firm substrate. When a gap is present between the metal deck and the vertical surface, loose lay a 6" wide section of 24 gauge sheet metal at the angle change to ensure a solid surface for adhering the membrane. When the gap between the metal deck and vertical substrate is greater than 2", install a section of insulation to fill in the gap prior to loose laying the 6" wide section of sheet metal.
8. **Details:** Proper details ensure the integrity of the Air and Vapor Barrier. Details must be completed using the following materials: VapAir Seal MD material, Pressure-Sensitive ElastoForm Flashing and VapAir Seal Foam Flashing. Please refer to applicable Versico details for penetrations and ties-ins.

Copyright 2024 Versico

Versico and VersiFleece are Trademarks of Versico

This specification represents the applicable information available at the time of its publication. Owners, specifiers and Versico authorized roofing contractors should consult Versico or their Versico Independent Sales Representative for any information, which has subsequently been made available.

Review the appropriate Versico warranty for specific warranty coverage, terms, conditions and limitations.



SPECIFICATION

SUPPLEMENT

G-13-23

VacuSeal™ Vent Secured Roofing Systems

January 2024

The information contained in this supplement serves as a criteria for Specifiers and Authorized Contractors regarding the design and installation of Versico Roofing Systems and use of roof vents for a vent secured roofing system. In addition to the information contained herein, attachment details are included to provide the Specifiers and Authorized Contractors with quick access to specific information. Specifiers and Authorized Contractors are advised to reference all applicable details included with this spec supplement.

This alternate method with vent securement is for securing Versico’s VersiGard/VersiGard White (EPDM), VersiWeld (TPO), VersiFlex (PVC) or VersiFlex (KEE HP) membrane and is intended to be used with products included within the Versico’s Thermoset or Thermoplastic Specification and Details.

A. Description

The VacuSeal™ Vent Secured Roofing System incorporates the use of a loose-laid thermoset or thermoplastic membranes in conjunction with a sealed roofing/substrate assembly and VacuSeal Roof Vents. The roof vents locations are pre-determined by engineered drawings processed through Versico, based on project location and conditions. Air distribution strips are positioned beneath the membrane linking the VacuSeal Vents and facilitating air movement beneath the membrane. The insulation is loose-laid in a single or multiple layers and overlaid with a 1/2 inch gypsum cover board.

NOTE: A continuous air seal is critical for performance of the system, closely follow details at perimeters and penetrations.

VacuSeal Vent Secured Roofing System is limited to 20 Year Maximum warranty with wind speed coverage up to 90 mph. Specific enhancements will be required along the perimeter for systems requiring warranty wind speed coverage greater than 72 mph. Contact Versico for enhancement requirements.

VacuSeal™ Membrane Systems Warranty Options

Years	Thermoset (VersiGard/VersiGard White EPDM) OR Thermoplastic Membranes (VersiWeld TPO/VersiFlex PVC/VersiFlex KEE HP)		
	Warranty Wind Speed	Minimum Membrane Thickness (1)	Additional Puncture Coverage
	55, 72, 80 or 90 mph		
5, 10, 15 or 20 year	√(2)	60-mil	Not Available

Notes: √= Acceptable

- (1) All “T-Joints” must be overlaid with appropriate flashing material.
- (2) Perimeter enhancements required for wind speed coverage greater than 72mph. Contact Versico for requirements.

B. Quality Assurance

1. This securement method using VacuSeal Vents requires a pre-engineered drawing developed by VacuSeal Technology identifying locations of all vents in the system and specific engineering evaluations completed by VacuSeal Technology. Prior to installation, approved engineered drawing must be obtained.

2. This roofing assembly must be installed by an authorized applicator who has been trained for the installation of VACUSEAL Roof Vents and its components in compliance with the approved engineered drawing.
3. Consult Versico to ensure proper seal detailing is provided and appropriate Versico roofing details are selected.
4. In addition to final inspection by Versico, project scheduling must be coordinated with Versico for in-progress inspection coordination.

C. Submittals

1. Prior to starting work, the roofing contractor must submit the following:
 - a. Roofing Architectural Drawings and Details must be submitted to VACUSEAL Technology, 13000 S. Tyron St., Suite F-193, Charlotte, NC 28278, (704)-900-1220, contact@VacuSealroofsystems.com prior to installation to secure an engineered layout for the vent locations.
 - b. Submit VACUSEAL engineered layout to Versico showing VACUSEAL vent layout, location of air distribution strips, details of construction and identification of materials.
2. No deviations will be allowed without prior written approval.
3. Upon completion of the installed work, submit notice of completion to Versico to schedule Final Inspection.

D. Products

Products listed in "Part II" of the Versico Thermoset/Thermoplastic Roofing System Specifications can be used as part of the VacuSeal Vent Secured Roofing System. In addition, products listed herein are specific to this system:

1. **VacuSeal Roof Vent:** A ridged injection-molded PVC plastic roof vent with integrated plastic flange base.
2. **Air Distribution Strip:** A 10" wide, orange polypropylene mesh used to distribute air underneath the membrane and VacuSeal roof vent. Available in rolls of 10" wide by 500' long.
3. **Sealant Tape:** An elastomeric butyl rubber sealant, extruded on silicone coated paper, used in conjunction with a termination bar to secure and seal compression type flashing terminations.
4. **Versico VapAir Seal 725TR Air and Vapor Barrier** - A 40-mil thick composite consisting of 35-mil self-adhering rubberized asphalt membrane laminated to a 5-mil UV resistant poly film with an anti-skid.
5. **Versico VapAir Seal MD Air and Vapor Barrier** – a reinforced composite aluminum foil with self-adhesive SBS backing and removable poly release film. Used for direct application over metal decks.
6. **Versico VapAir Seal Flashing Foam** – a low pressure foam system that utilizes a non-flammable blowing agent. The foam is used to seal penetrations and reduce air leakage, especially at roof perimeters.
7. **VersiGard/VersiGard White Quick Applied Uncured Flashing:** A 6" X 100' and 9" or 12" wide by 50' long, 60-mil thick VersiGard **uncured** EPDM Flashing laminated to a 30-mil QA Seam Tape used in conjunction with EPDM Primer. VersiGard/VersiGard White EPDM Quick Applied uncured Flashing is used to flash inside and outside corners, pipes, scuppers and field fabricated pourable sealer pockets when the use of Versico pre-fabricated flashing accessories is not feasible.

E. Design Criteria

Follow current Versico specifications for installing roof membranes and seaming per specific membrane. [VersiGard/VersiGard White (EPDM), VersiWeld (TPO), VersiFlex (PVC) or VersiFlex (KEE HP)].

1. General

- a. The use of a sealed air barrier for this roofing system is required and is critical to the performance and function of this system. Follow all details at perimeters and penetrations.
- b. For this air equalization attachment method, night seal must be completed by the end of each day, perimeter seals must be completed along with the required number of vents in a specific area.

2. Re-Roof (Recover, No Tear-Off)

- a. To maintain continuous air seal, utilize existing roof membrane and replace or re-seal any flashings which are loose or damaged.

SUBSTRATE CRITERIA FOR VACUSEAL REROOF (RECOVER, NO TEAR-OFF) ⁽¹⁾

Acceptable Roof Deck / Substrate (1)	TPO Membrane	PVC / KEE HP PVC Membrane	EPDM Membrane
Existing Smooth Surface BUR (7) or Mineral Surface Cap Sheet	Direct Application (8) (9)	½" min. approved coverboard	Direct Application (2) (9)
Gravel Surfaced BUR (3) or Coal Tar Pitch (3) (4)	½" min. approved coverboard	½" min. approved coverboard	½" min. approved coverboard
Modified Bitumen (9)	Direct Application (6) (8)	½" min. approved coverboard	Direct Application (6) (8)
Existing Single-Ply (5)(9)	Direct Application	Direct Application	Direct Application
Sprayed-in-place Urethane	½" min. approved coverboard	½" min. approved coverboard	½" min. approved coverboard

Notes:

- 1) Existing roof system must be securely attached.
- 2) VersiGard (black) may be applied directly to the substrate provided asphalt on existing smooth surfaced built-up roof has a softening point above 185°F (85°C). VersiGard White (White-on-black) Roofing Systems are not recommended for direct application over smooth BUR or granule surface BUR or in conjunction with HP mat. Make sure substrate is clean and free of roofing cement and fresh asphalt to avoid sheet contamination and staining of white color membrane.
- 3) Loose gravel must be removed to avoid entrapment of moisture.
- 4) Existing coal tar could drip back into the building, especially when new insulation does not provide sufficient thermal value to prevent the surface of the coal tar from softening.
- 5) Not Approved over existing ballasted single-ply systems (even if ballast removed). An approved underlayment is required over existing roofing systems of any type.
- 6) Direct application permitted over smooth surfaced modified bitumen. Membrane shall be positioned with length of sheets parallel to modified bitumen field seams. At end laps or other locations where splices intersect modified bitumen field seams, 6" wide VersiWeld or VersiFlex Flashing must be heat welded over intersections. For VersiGard, 6" wide Uncured or Quick-Applied Flashing must be applied over intersections.
- 7) Existing Type III or IV smooth asphalt BUR only.
- 8) Possible staining/discoloration of light-colored membrane may result when installing this system directly over existing smooth surfaced BUR or modified bitumen. If aesthetics is critical, an approved insulation should be specified beneath the membrane.
- 9) Maximum warranty available 20 YR with 55 MPH peak gust wind speed coverage. Carlisle may be contacted for other warranty options.

3. Re-Roof (Partial Tear Off, Deck Not Exposed)

- a. Partial tear-off does not allow a continuous air seal below the membrane and these projects are not recommended for use with Vented Roof Systems, without verification of an existing air barrier.

4. New Construction / Re-Roof (Complete Tear-Off, Deck Exposed)

All deck types (Steel, Concrete, Wood, Cementitious Wood Fiber or Gypsum) require a continuous air seal which can be achieved utilizing an air barrier at the deck level.

F. Installation

1. Daily Seal

- a. On phased roofing, when the completion of flashings and terminations is not possible by the end of each workday, provisions must be taken to temporarily close the membrane to prevent water and air infiltration.
- b. Temporarily seal any loose membrane edge down slope using G400PS-2 Pourable Sealer (EPDM only), Flexible DASH Adhesive, hot asphalt, or a similar product so that the membrane edge will not buck water. Caution must be exercised to ensure positive draining during installation, temporary seal locations should be designated so that drainage is not restricted during construction by partially installed roof sections.
 - 1) When applying Flexible DASH Adhesive or other sprayed urethane foam, prime the surface of the membrane with Versico Primer to ensure proper adhesion.
 - 2) G400PS-2 Pourable Sealer, when utilized, shall be applied as follows:

- a) The two Pourable Sealer components must be mixed in accordance with the instructions on the container labels.
- b) Apply the Pourable Sealer along the loose edge of the EPDM membrane. If necessary, use a trowel to spread Pourable Sealer to achieve complete coverage.
- c. When tie-in to existing built-up roofs, remove the gravel. The surface must be clean and dry.
- d. After embedding membrane in daily seal material, CHECK FOR CONTINUOUS CONTACT. Provide continuous pressure over the length of the temporary seal. Provide weight evenly distributed along the length of the daily seal to reduce the wind effect on the continuous temporary seal.

NOTE: The use of rigid wood nailers is not recommended due to warping. Constant compression cannot be achieved on an uneven substrate.

- e. When work is resumed, pull the imbedded membrane free; trim and remove daily seal material from membrane before continuing installation of adjoining sections.
2. Follow guidelines above for the installation and air sealing of roof deck perimeters and penetrations.
 3. After placement of insulation and coverboard, layout the vents and air distribution strips per engineered layout drawing provided by VacuSeal Technology. Mark placement of vents on substrate with chalk or marker.
 4. Loose lay roofing membrane over the air distribution strips and air vent locations. Allow the membrane to relax.
 5. Place the VacuSeal Roof Vents on previous marks and cut out membrane as needed for installation of vent, follow details for specific requirements for each vent.
 6. Flash VacuSeal Roof Vent per requirements outlined in detail.
 7. Repeat installation for additional vents.

G. Field Quality Control

1. Contact VacuSeal Technology technical staff for vacuum test of roof system to verify airtight assembly.
2. Repair or remove and replace components of membrane roofing system where inspections indicate that they do not comply with specified requirements.

H. Associated Installation Details

Roof Assembly Over Existing Single-Ply Roof	V-0.1
Roof Assembly Over Existing Asphaltic Roof.....	V-0.2
Roof Assembly Over Steel Deck.....	V-0.3
Roof Assembly Over Poured-In-Place Concrete Deck.....	V-0.4
Roof Assembly Over Concrete Plank.....	V-0.5
Roof Assembly Over Lightweight Concrete Deck.....	V-0.6
Roof Assembly Wood Deck	V-0.7
Roof Edge: Roof Recover	V-1.1
Roof Edge: Tear-Off & Re-Roofing	V-1.2
Curb Base Flashing – New Construction and Re-Roof (Recover).....	V-5.1
Roof Drain: Re-Roof (Recover).....	V-6.1
Roof Drain: New Construction.....	V-6.2
VacuSeal Vent with Pre-Applied Skirt Flashing.....	V-8.0
Pipe/Structural Steel Tube Through Metal Deck.....	V-8.1
Multiple Penetrations Through Steel Deck – New Construction	V-8.2
Single Penetration Through Existing Roof Assembly.....	V-8.3
Cluster of Penetrations Through Existing Roof Assembly.....	V-8.4
Hot Stack Air Flashing – Option A.....	V-8.5A
Hot Stack Air Flashing – Option B.....	V-8.5B
Parapet With Membrane Air Barrier	V-12.1
Parapet/Curb: Concrete/Lightweight Concrete Used as an Air Barrier.....	V-12.2
Parapet or Wall: New Construction and Re-Roof (Recover).....	V-12.3

ROOF ASSEMBLY WITHOUT NEW INSULATION

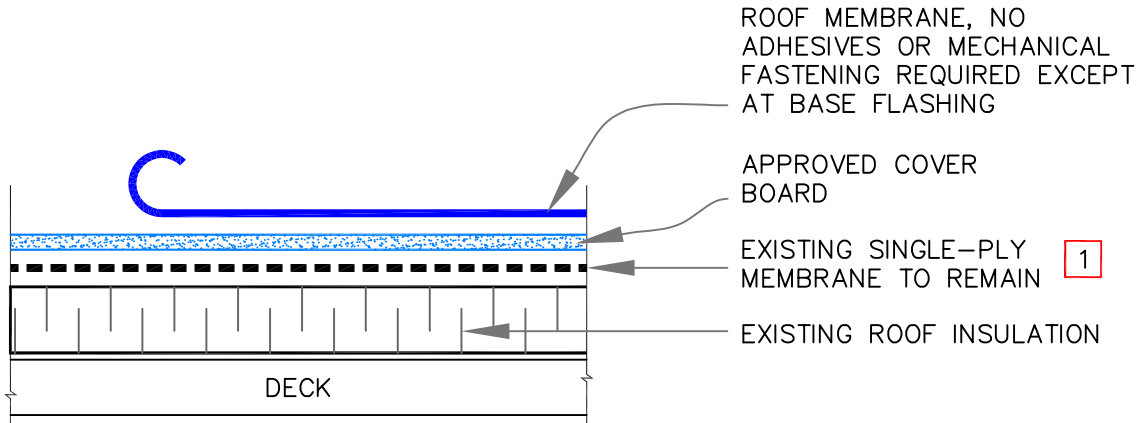

NOTE:

1. EXISTING ROOF MEMBRANE MAY BE USED AS AN AIR BARRIER. IT WILL REQUIRE THOROUGH INSPECTION FOR BREACHES, DAMAGES, AND AIR TIGHTNESS OF EXISTING FLASHING. SEAL ALL DEFICIENT CONDITIONS TO ACHIEVE AN AIRTIGHT AIR BARRIER.

ROOF ASSEMBLY WITH NEW INSULATION

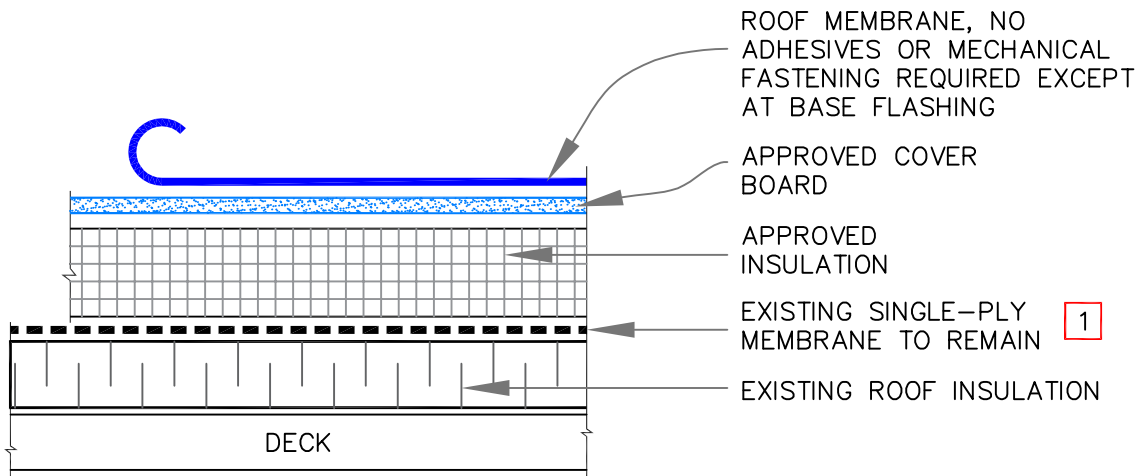

See sheets [V-0.1](#) to [V-0.7](#) & Specs for additional information



ROOF ASSEMBLY OVER EXISTING SINGLE-PLY ROOF

- NEW MEMBRANE
- EXISTING MEMBRANE
- INSULATION
- 0 SEE NOTE(S)

VENT SECURED ROOFING SYSTEM

V-0.1

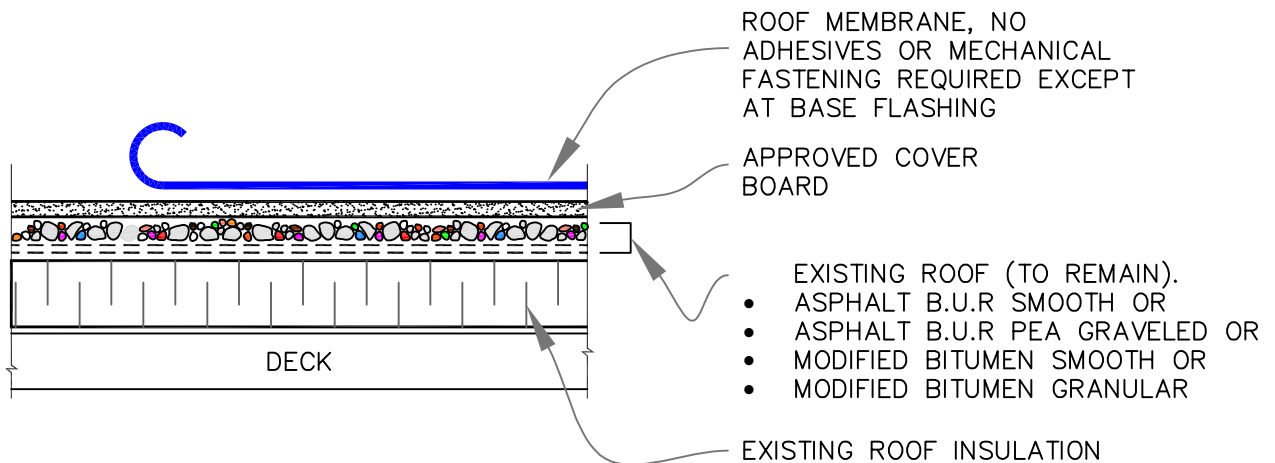

NOTES:

1. EXISTING ROOF MEMBRANE MAY BE USED AS AN AIR BARRIER. IT WILL REQUIRE THOROUGH INSPECTION FOR BREACHES, DAMAGES, BLISTERS, WRINKLES AND AIR TIGHTNESS OF EXISTING FLASHING. SEAL ALL DEFICIENT CONDITIONS TO ACHIEVE AN AIRTIGHT AIR BARRIER.
2. FOR NEW ASSEMBLY OVER COAL TAR PITCHED ROOF, CONTACT VERSICO.
3. LOOSE GRAVEL OR GRANULES MUST BE REMOVED AND THE SURFACE SHALL BE LEVELED.

See sheets [V-0.1](#) to [V-0.7](#) & Specs for additional information



ROOF ASSEMBLY OVER EXISTING ASPHALTIC ROOF

	NEW MEMBRANE
	EXISTING MEMBRANE
	INSULATION
	SEE NOTE(S)

VENT SECURED ROOFING SYSTEM

V-0.2

OPTION A

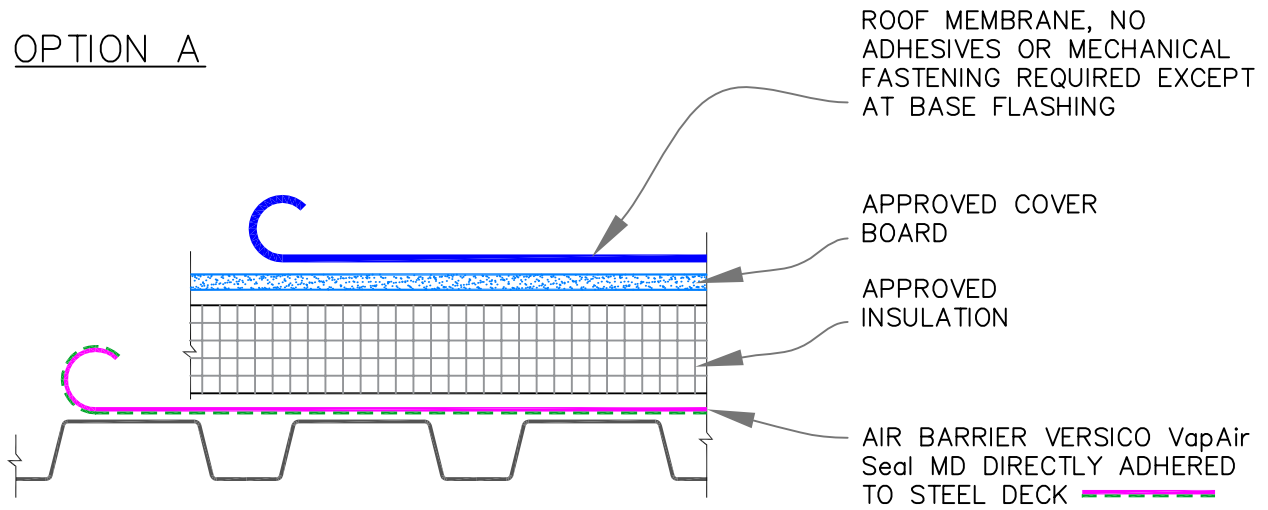

OPTION B

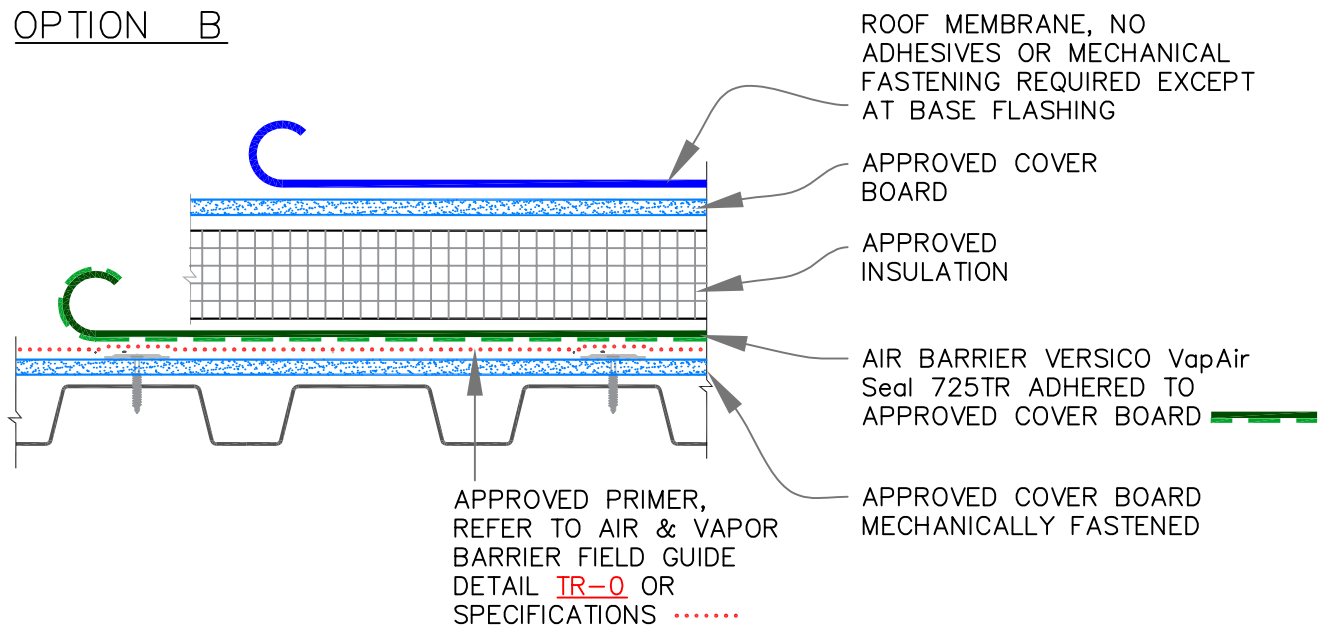

See sheets V-0.1 to V-0.7 & Specs for additional information



ROOF ASSEMBLY – OVER STEEL DECK

	NEW MEMBRANE
	EXISTING MEMBRANE
	INSULATION
	SEE NOTE(S)

VENT SECURED ROOFING SYSTEM

V-0.3

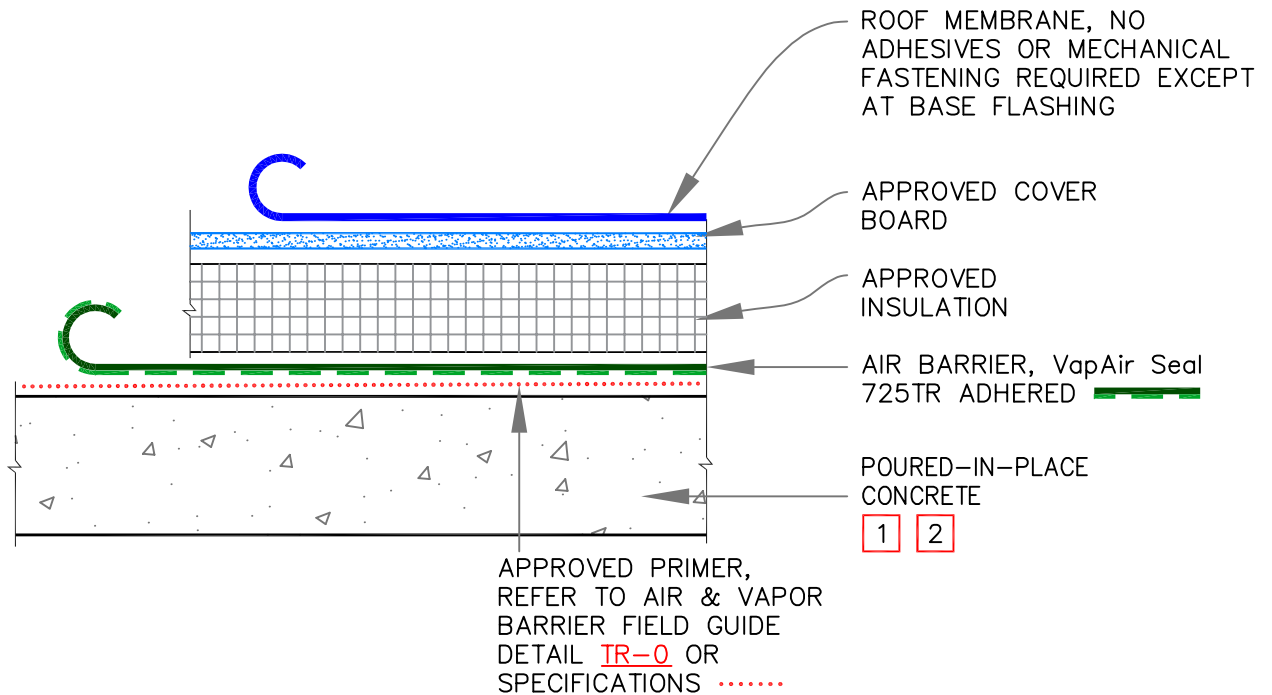

NOTES:

1. THE SUBSTRATE MAY NOT REQUIRE AN ADDITIONAL LAYER OF AIR BARRIER. TO ENSURE THAT A CONTINUOUS AIR-SEAL IS PROVIDED, THE SUBSTRATE MUST BE INSPECTED FOR BREACHES FOR AIR INFILTRATION AT CRACKS, JOINTS, PENETRATIONS, ROOF EDGES, PARAPET WALLS, AND SIMILAR CONDITIONS.

See sheets [V-0.1](#) to [V-0.7](#) & Specs for additional information



ROOF ASSEMBLY OVER POURED-IN-PLACE CONCRETE DECK	<p>— NEW MEMBRANE</p> <p>- - - EXISTING MEMBRANE</p> <p>INSULATION</p> <p>0 SEE NOTE(S)</p>
--	---

VENT SECURED ROOFING SYSTEM
V-0.4

HOLLOW CORE CONCRETE PLANKS

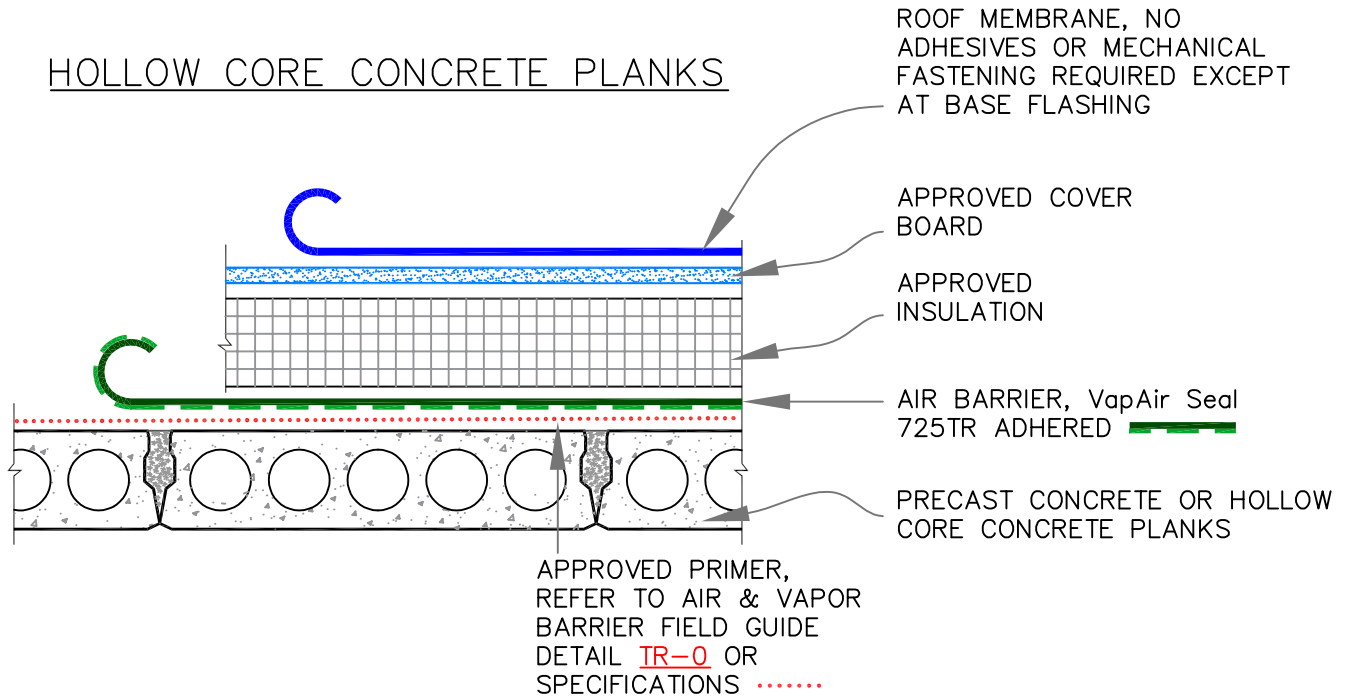

HOLLOW CORE CONCRETE PLANKS WITH TOPPING

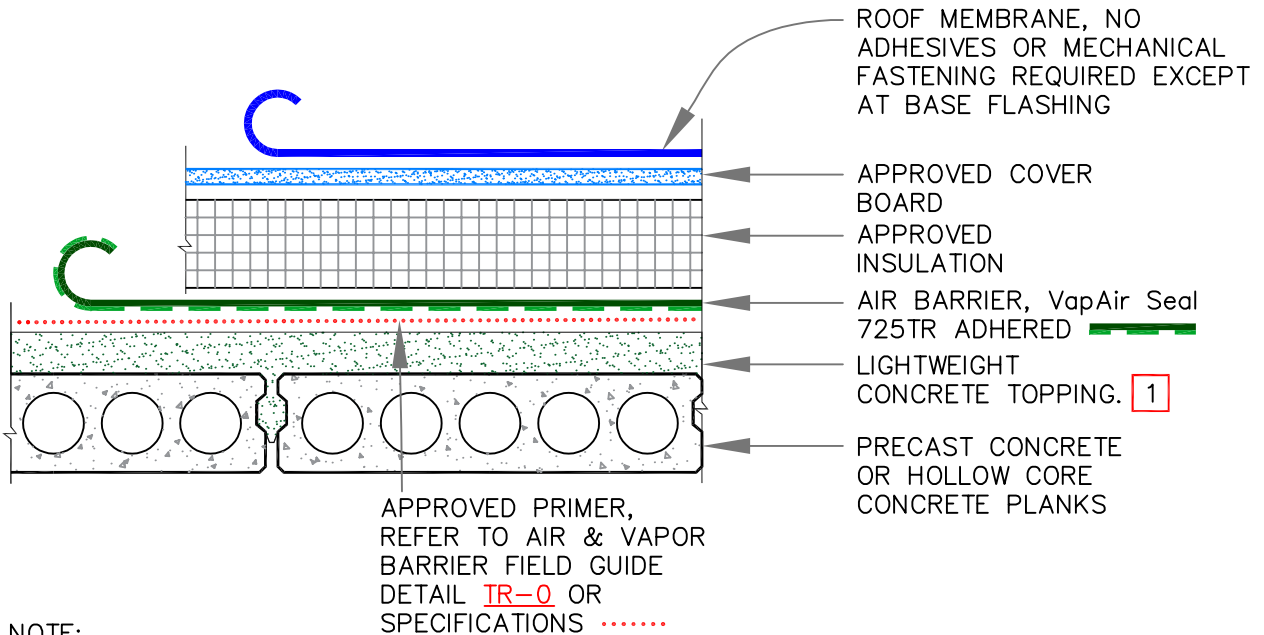

NOTE:

1. THE SUBSTRATE MAY NOT REQUIRE AN ADDITIONAL LAYER OF AIR BARRIER WHEN CONCRETE TOPPING EXISTS. TO ENSURE THAT A CONTINUOUS AIR-SEAL IS PROVIDED, THE SUBSTRATE MUST BE INSPECTED FOR BREACHES FOR AIR INFILTRATION AT CRACKS, JOINTS, PENETRATIONS, ROOF EDGES, PARAPET WALLS, AND SIMILAR CONDITIONS & PROPER REPAIRS MUST BE PERFORMED.

See sheets V-0.1 to V-0.7 & Specs for additional information



ROOF ASSEMBLY OVER CONCRETE PLANKS

	NEW MEMBRANE
	EXISTING MEMBRANE
	INSULATION
	SEE NOTE(S)

VENT SECURED ROOFING SYSTEM

V-0.5

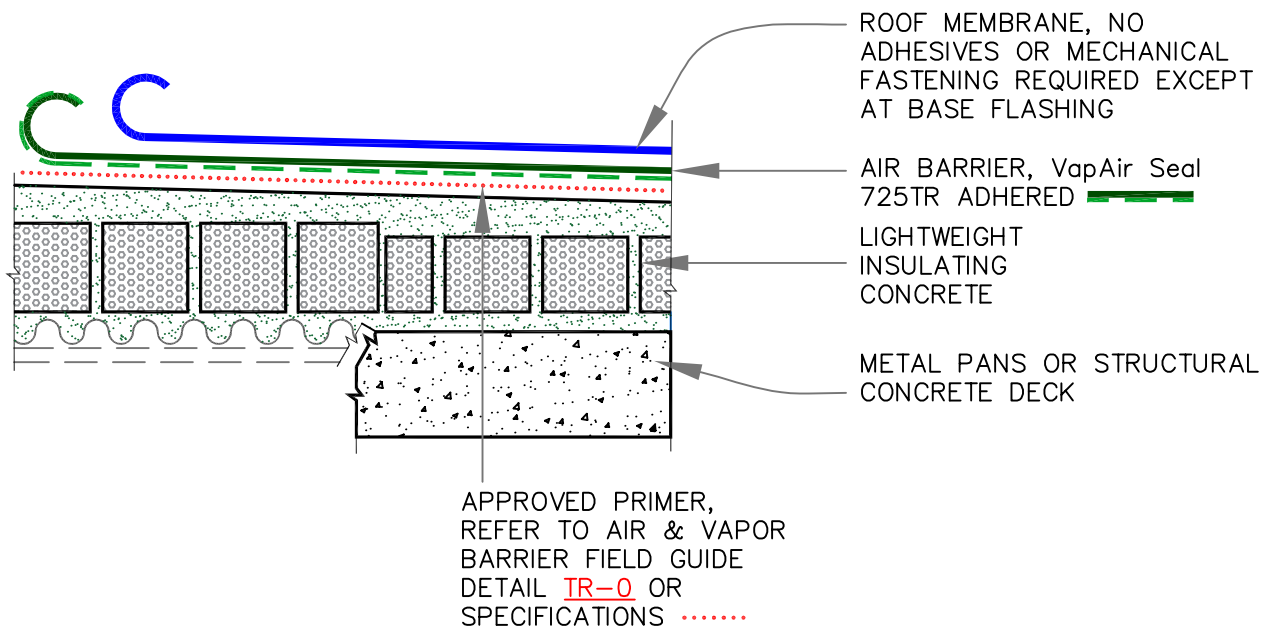

NOTE:

1. THE SUBSTRATE MAY NOT REQUIRE AN ADDITIONAL LAYER OF AIR BARRIER WHEN CONCRETE TOPPING EXISTS. TO ENSURE THAT CONCRETE SUBSTRATE PROVIDES A CONTINUOUS AIR-SEAL, THE SUBSTRATE MUST BE INSPECTED FOR AIR INFILTRATION. INSPECT FOR BREACHES CRACKS, JOINTS, PENETRATIONS, ROOF EDGES, PARAPET WALLS JUNCTIONS, AND SIMILAR CONDITIONS. PROPER REPAIRS MUST BE PERFORMED TO CREATE AN AIR BARRIER.

See sheets [V-0.1](#) to [V-0.7](#) & Specs for additional information



<p>ROOF ASSEMBLY OVER LIGHTWEIGHT CONCRETE DECK</p>	<p>— NEW MEMBRANE</p> <p>- - - EXISTING MEMBRANE</p> <p>□ INSULATION</p> <p>0 SEE NOTE(S)</p>
---	---

<p>VENT SECURED ROOFING SYSTEM</p> <p>V-0.6</p>

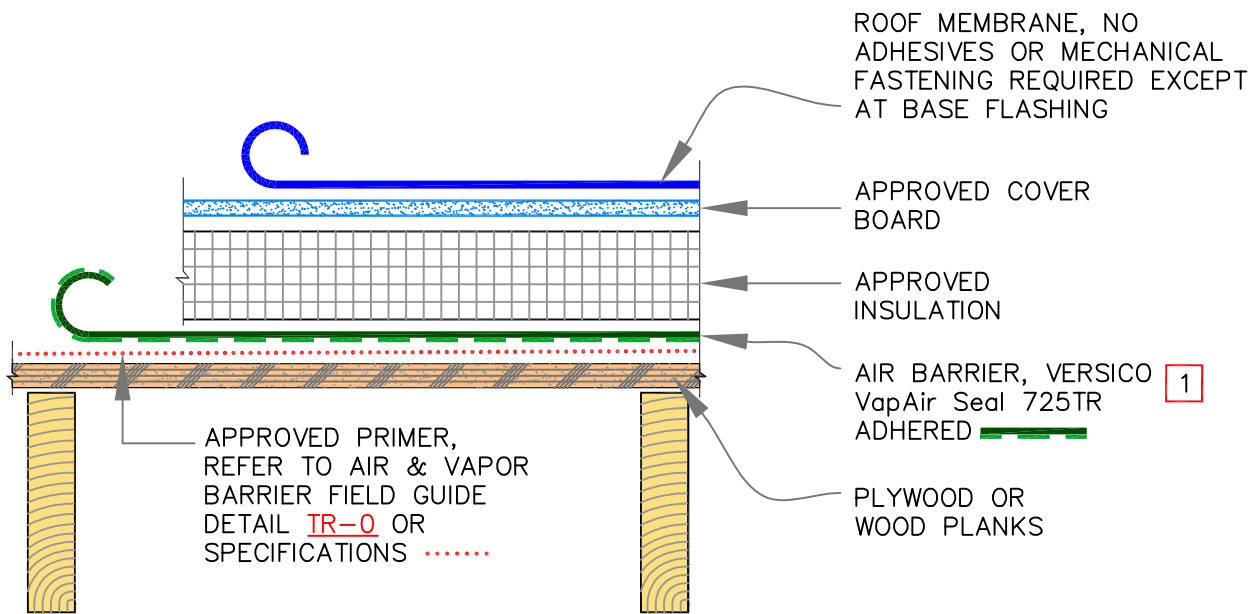

NOTES:

1. TO AVOID POTENTIAL DAMAGE TO AIR AND VAPOR BARRIER, PROTRUDING NAILS/FASTENERS SHALL BE REMOVED AND REPLACED WITH HEAVY GAUGE THREADED FASTENERS.
2. AS AN OPTION, THE AIR AND VAPOR BARRIER MAY BE ADHERED TO MECHANICALLY FASTENED SECUROCK OR DensDeck PRIME COVER BOARD.

See sheets [V-0.1](#) to [V-0.7](#) & Specs for additional information



ROOF ASSEMBLY OVER WOOD DECK	<table border="0"> <tr> <td style="border-bottom: 1px solid black; width: 20px; height: 10px;"></td> <td>NEW MEMBRANE</td> </tr> <tr> <td style="border-bottom: 1px dashed black; width: 20px; height: 10px;"></td> <td>EXISTING MEMBRANE</td> </tr> <tr> <td style="border-bottom: 1px solid black; width: 20px; height: 10px; background-image: linear-gradient(to right, black 1px, transparent 1px); background-size: 4px 4px;"></td> <td>INSULATION</td> </tr> <tr> <td style="border: 1px solid red; text-align: center; width: 20px; height: 20px; vertical-align: middle;">0</td> <td>SEE NOTE(S)</td> </tr> </table>		NEW MEMBRANE		EXISTING MEMBRANE		INSULATION	0	SEE NOTE(S)
	NEW MEMBRANE								
	EXISTING MEMBRANE								
	INSULATION								
0	SEE NOTE(S)								

VENT SECURED ROOFING SYSTEM
V-0.7

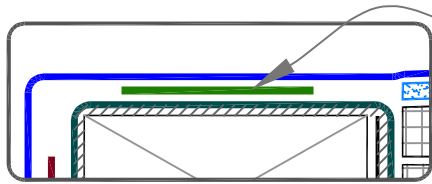

IN LIEU OF BONDING ADHESIVE,
3" (7.5cm) WIDE QA SEAM
TAPE MAY BE USED WITH
PRIMER TO SEAL BOTH THE
MEMBRANES

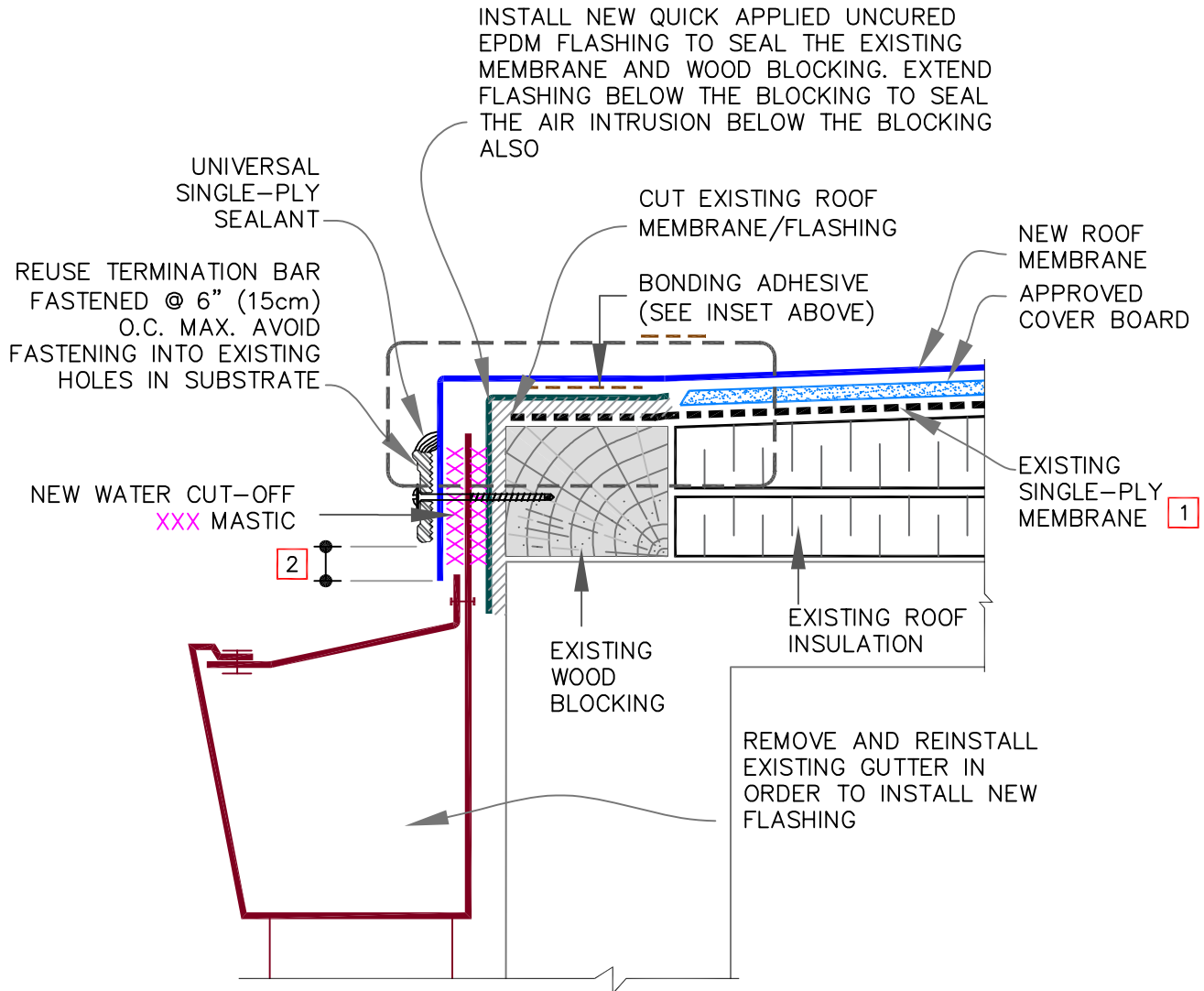





NOTES:

1. EXISTING ROOF MEMBRANE MAY BE USED AS AN AIR BARRIER. IT WILL REQUIRE THOROUGH INSPECTION FOR BREACHES, DAMAGES, AND AIR TIGHTNESS OF EXISTING FLASHING. SEAL ALL DEFICIENT CONDITIONS TO ACHIEVE AN AIRTIGHT AIR BARRIER.
2. ALLOW MEMBRANE SHEET TO EXTEND 1/2" (1.5cm) MINIMUM BELOW THE METAL TERMINATION BAR.

See sheets [V-0.1](#) to [V-0.7](#) & Specs for additional information



ROOF EDGE: ROOF RECOVER

-  NEW MEMBRANE
-  EXISTING MEMBRANE
-  INSULATION
-  SEE NOTE(S)

VENT SECURED
ROOFING SYSTEM

V-1.1

IN LIEU OF BONDING ADHESIVE,
3" (7.5cm) WIDE QA SEAM
TAPE MAY BE USED WITH
PRIMER TO SEAL BOTH THE
MEMBRANES

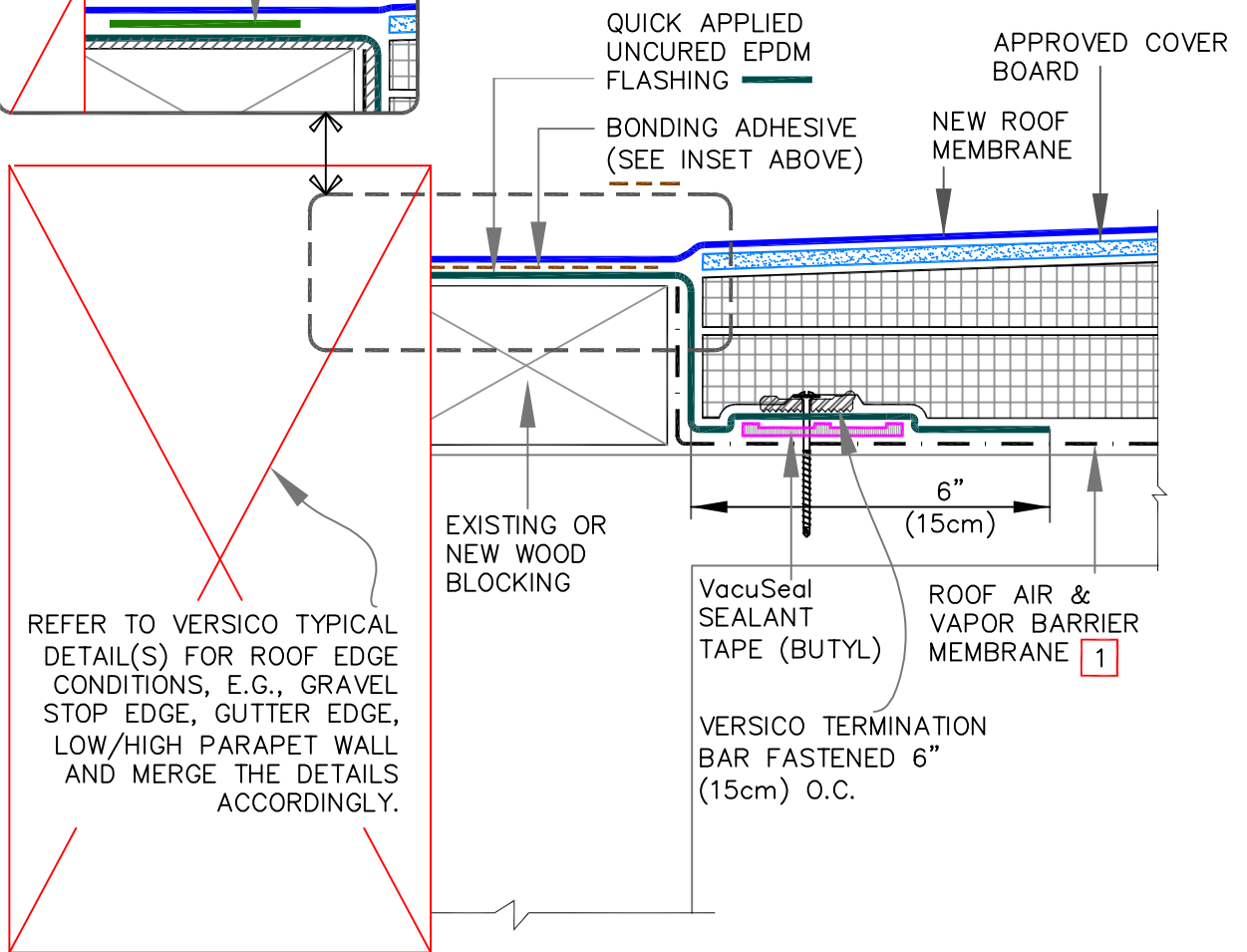
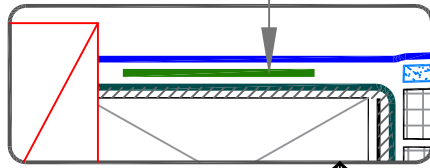

REFER TO VERSICO TYPICAL
DETAIL(S) FOR ROOF EDGE
CONDITIONS, E.G., GRAVEL
STOP EDGE, GUTTER EDGE,
LOW/HIGH PARAPET WALL
AND MERGE THE DETAILS
ACCORDINGLY.

VacuSeal
SEALANT
TAPE (BUTYL)

ROOF AIR &
VAPOR BARRIER
MEMBRANE 1

VERSICO TERMINATION
BAR FASTENED 6"
(15cm) O.C.

NOTES:

1. USE VapAir Seal 725TR AIR AND VAPOR BARRIER ON CONCRETE DECKS.
2. IN CASE OF METAL DECK, COORDINATE WITH VERSICO.

See sheets [V-0.1](#) to [V-0.7](#) & Specs for additional information



ROOF EDGE: TEAR-OFF & REROOFING

	NEW MEMBRANE
	EXISTING MEMBRANE
	INSULATION
	SEE NOTE(S)

VENT SECURED ROOFING SYSTEM

V-1.2

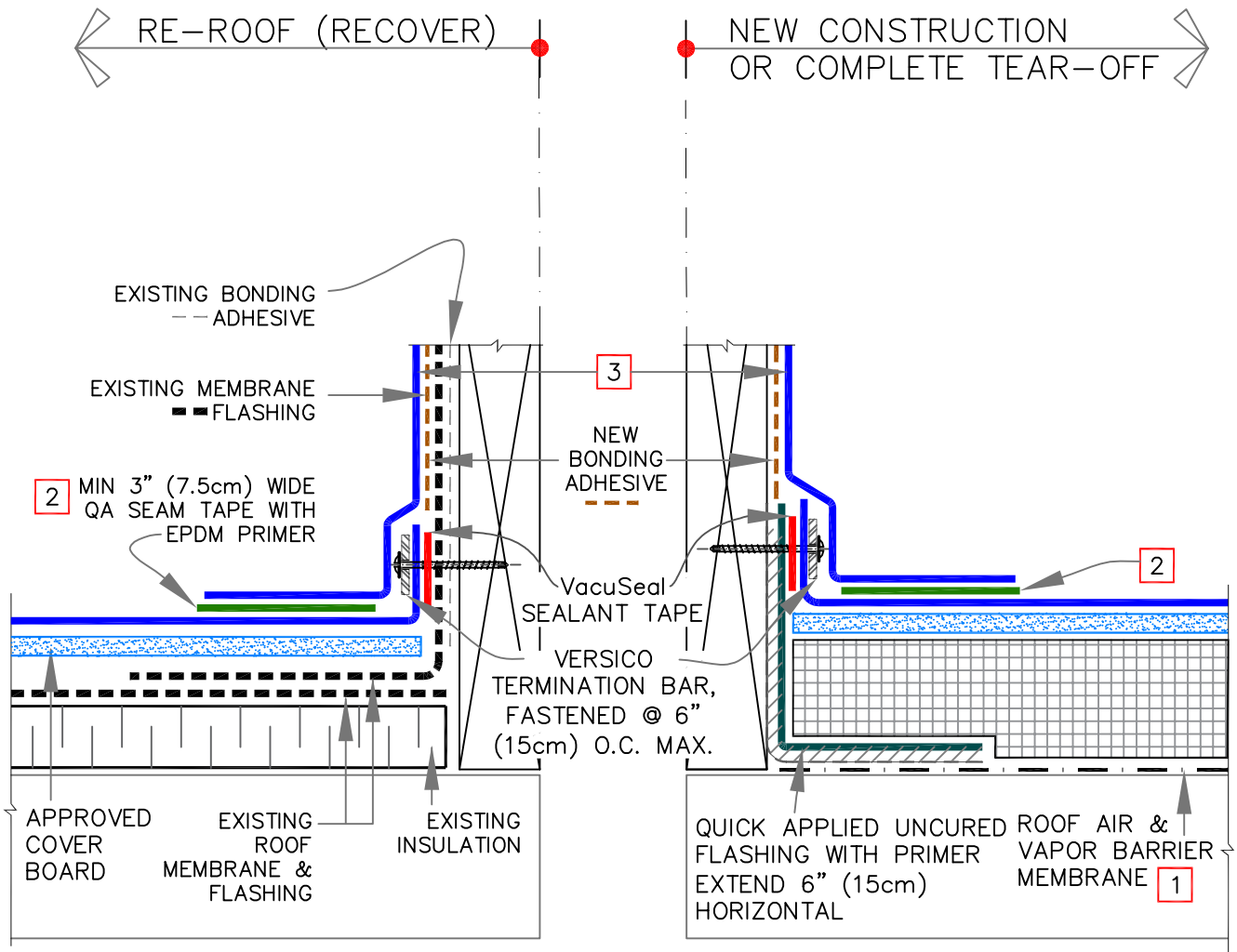

NOTES:

1. ON STEEL DECKS DIRECTLY ADHERE VERSICO VapAir Seal MD. USE VERSICO VapAir Seal 725TR ON CONCRETE & WOOD DECKS OR DECKS WITH APPROVED COVER BOARDS.
2. FOR ADDITIONAL INFORMATION, REFER TO VERSICO'S THERMOSET DETAIL [VGC-5.1](#) FOR EPDM AND THERMOPLASTIC DETAIL [TPC-5.1](#) FOR TPO/PVC.
3. SELF-ADHERING EPDM CURB WRAP MAY BE SUBSTITUTED AS FLASHING ON EPDM ROOFS.

See sheets [V-0.1](#) to [V-0.7](#) & Specs for additional information



CURB BASE FLASHING – NEW CONSTRUCTION AND RE-ROOF (RECOVER)	<table border="0"> <tr> <td style="border: 1px solid black; width: 20px; height: 10px; background-color: blue;"></td> <td>NEW MEMBRANE</td> </tr> <tr> <td style="border: 1px solid black; width: 20px; height: 10px; background-color: black;"></td> <td>EXISTING MEMBRANE</td> </tr> <tr> <td style="border: 1px solid black; width: 20px; height: 10px; background-image: linear-gradient(to right, black 1px, transparent 1px); background-size: 4px 4px;"></td> <td>INSULATION</td> </tr> <tr> <td style="border: 1px solid black; width: 20px; height: 10px; text-align: center; color: red; font-weight: bold;">0</td> <td>SEE NOTE(S)</td> </tr> </table>		NEW MEMBRANE		EXISTING MEMBRANE		INSULATION	0	SEE NOTE(S)
	NEW MEMBRANE								
	EXISTING MEMBRANE								
	INSULATION								
0	SEE NOTE(S)								

VENT SECURED ROOFING SYSTEM
V-5.1

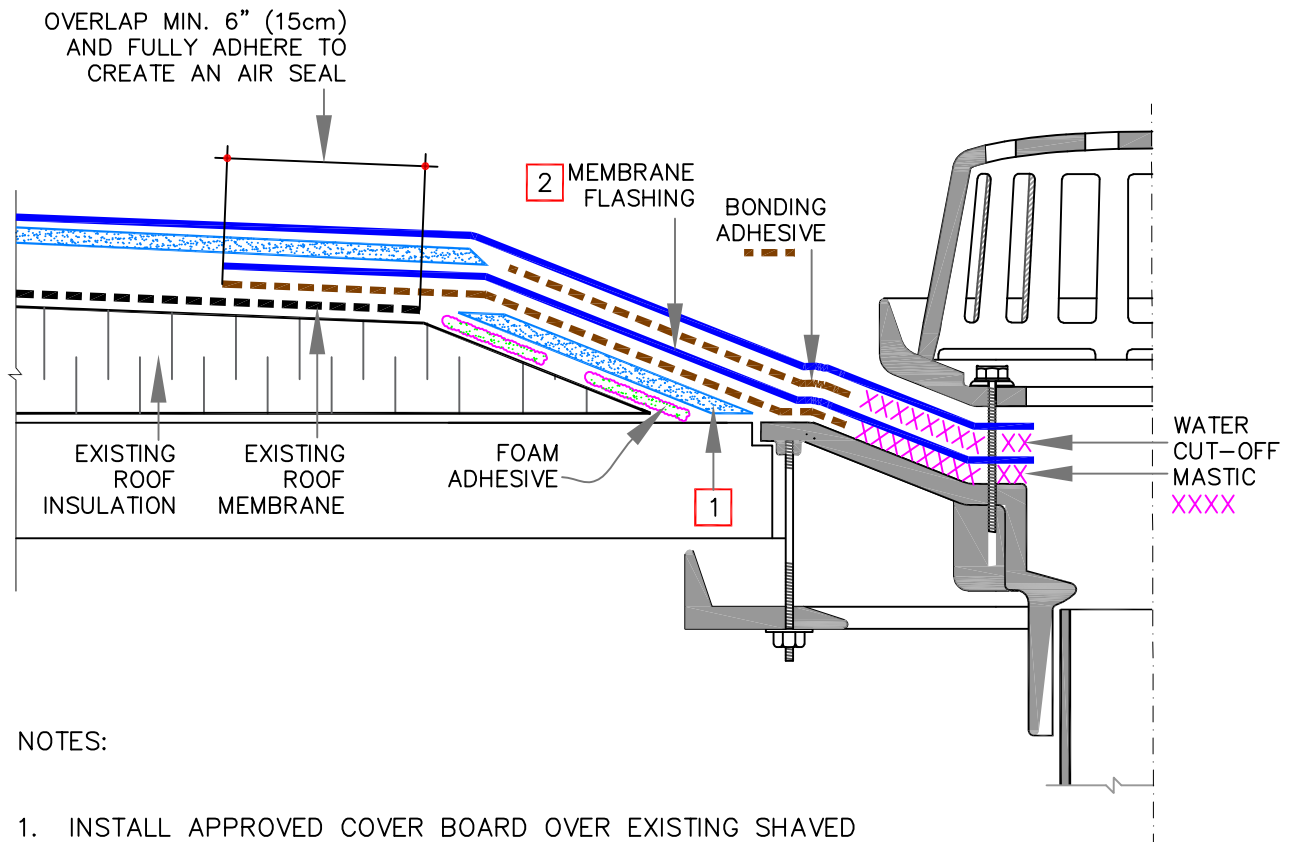

NOTES:

1. INSTALL APPROVED COVER BOARD OVER EXISTING SHAVED INSULATION. CREATE A PROPER SMOOTH SUMP. SET IN FOAM ADHESIVE.
2. FULLY ADHERE MEMBRANE FLASHING TO ACHIEVE AIRTIGHT CONDITION BETWEEN DRAIN AND EXISTING ROOF MEMBRANE. WHERE, THERE IS EXISTING ROOF VAPOR BARRIER, CUT IT BACK, IN ORDER TO PROPERLY AIR SEAL.
3. FOR ADDITIONAL INFORMATION, REFER TO VERSICO'S THERMOSET DETAIL [VGC-6](#) FOR EPDM AND THERMOPLASTIC DETAIL [IPC-6](#) FOR TPO/PVC.

See sheets [V-0.1](#) to [V-0.7](#) & Specs for additional information



ROOF DRAIN: RE-ROOF (RECOVER)	
	NEW MEMBRANE EXISTING MEMBRANE INSULATION 0 SEE NOTE(S)

VENT SECURED ROOFING SYSTEM
V-6.1

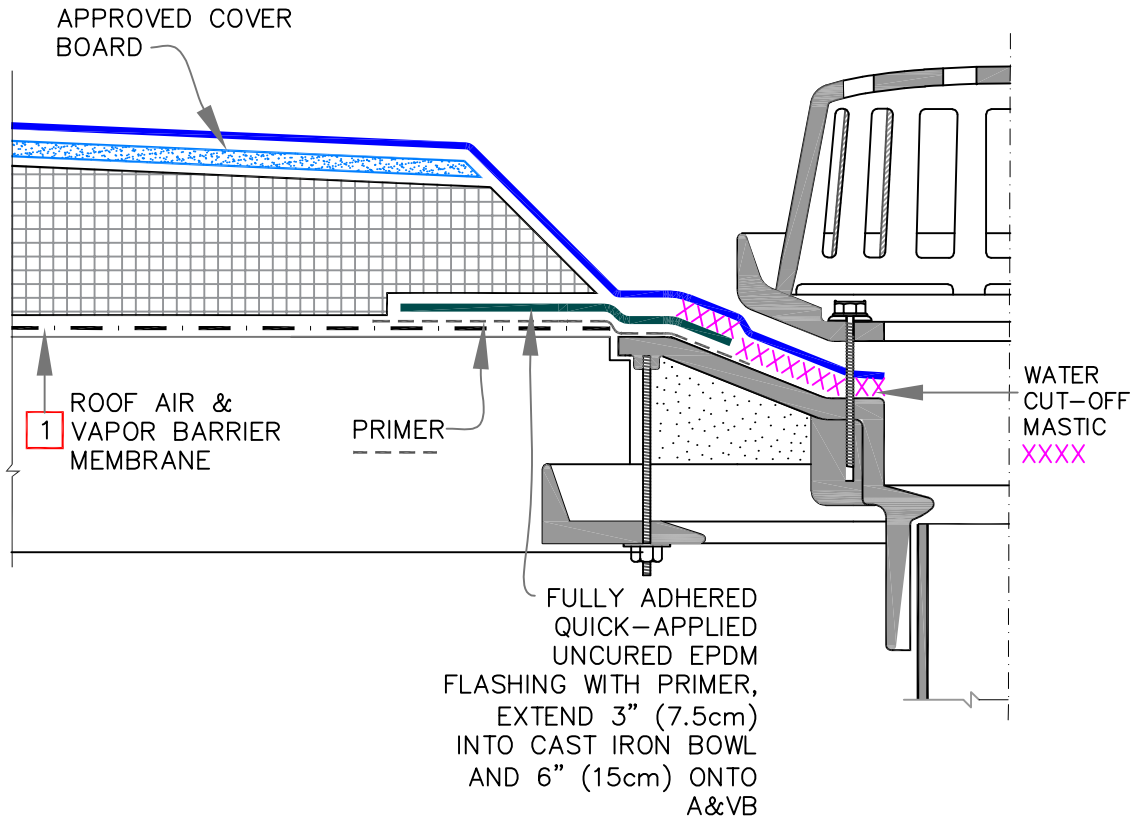

NOTES:

1. ON STEEL DECKS DIRECTLY ADHERE VERSICO VapAir Seal MD. USE VERSICO VapAir Seal 725TR ON CONCRETE & WOOD DECKS OR DECKS WITH APPROVED COVER BOARDS.
2. FOR ADDITIONAL INFORMATION, REFER TO VERSICO'S THERMOSET DETAIL [VGC-6](#) FOR EPDM AND THERMOPLASTIC DETAIL [IPC-6](#) FOR TPO/PVC.

See sheets [V-0.1](#) to [V-0.7](#) & Specs for additional information



ROOF DRAIN: NEW CONSTRUCTION

	NEW MEMBRANE
	EXISTING MEMBRANE
	INSULATION
	SEE NOTE(S)

VENT SECURED ROOFING SYSTEM

V-6.2

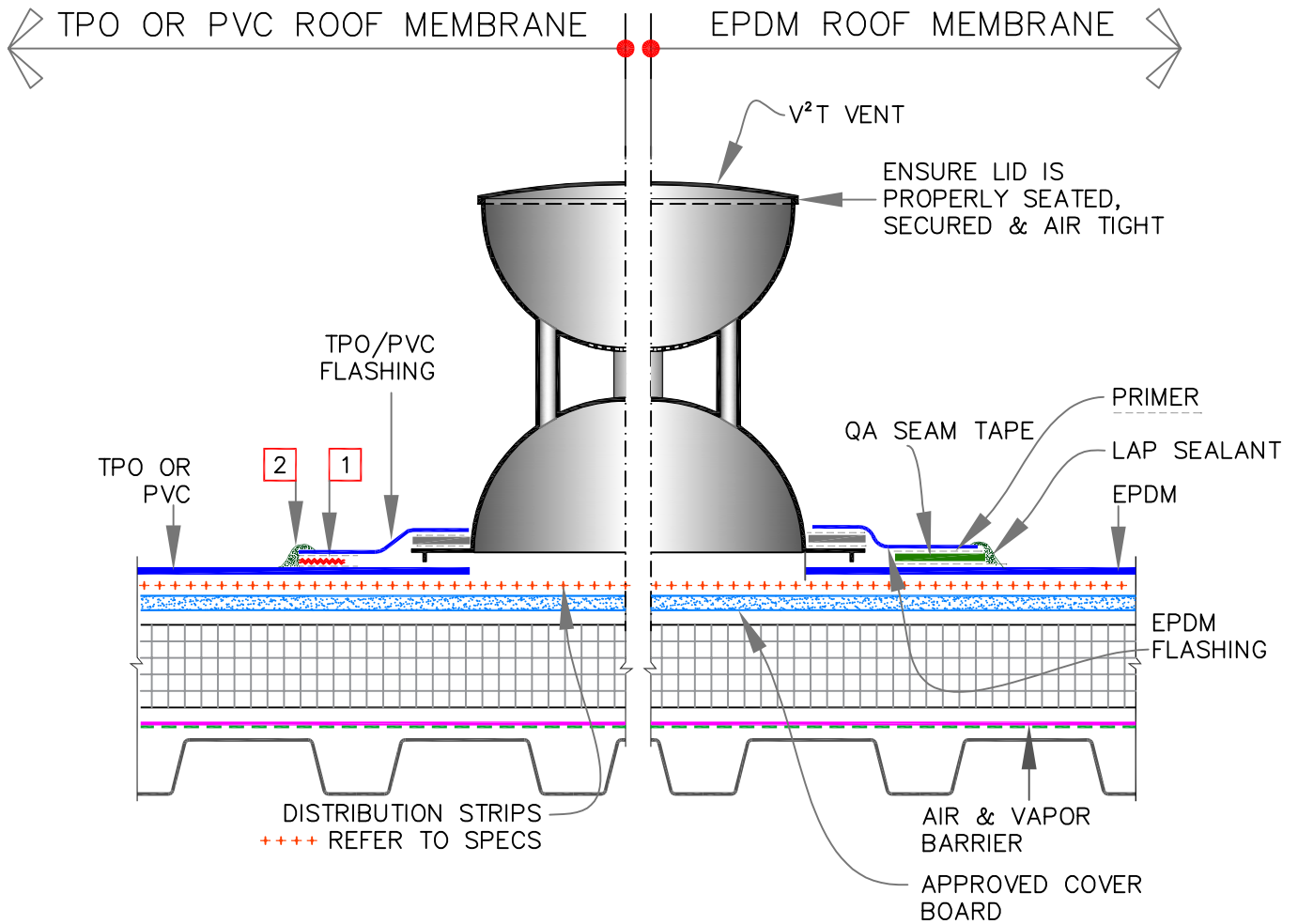

NOTES:

1. HOT AIR WELD, MIN. 1-1/2" (4cm).
2. APPROXIMATELY 1/8" (0.5cm) DIAMETER BEAD OF CUT-EDGE SEALANT IS REQUIRED ON CUT EDGES OF REINFORCED TPO MEMBRANE.

See sheets [V-0.1](#) to [V-0.7](#) & Specs for additional information



V ² T VENT WITH PRE-APPLIED SKIRT FLASHING	<ul style="list-style-type: none"> NEW MEMBRANE EXISTING MEMBRANE INSULATION 0 SEE NOTE(S)
---	---

<p>VENT SECURED ROOFING SYSTEM</p> <p style="font-size: 24px; font-weight: bold;">V-8.0</p>

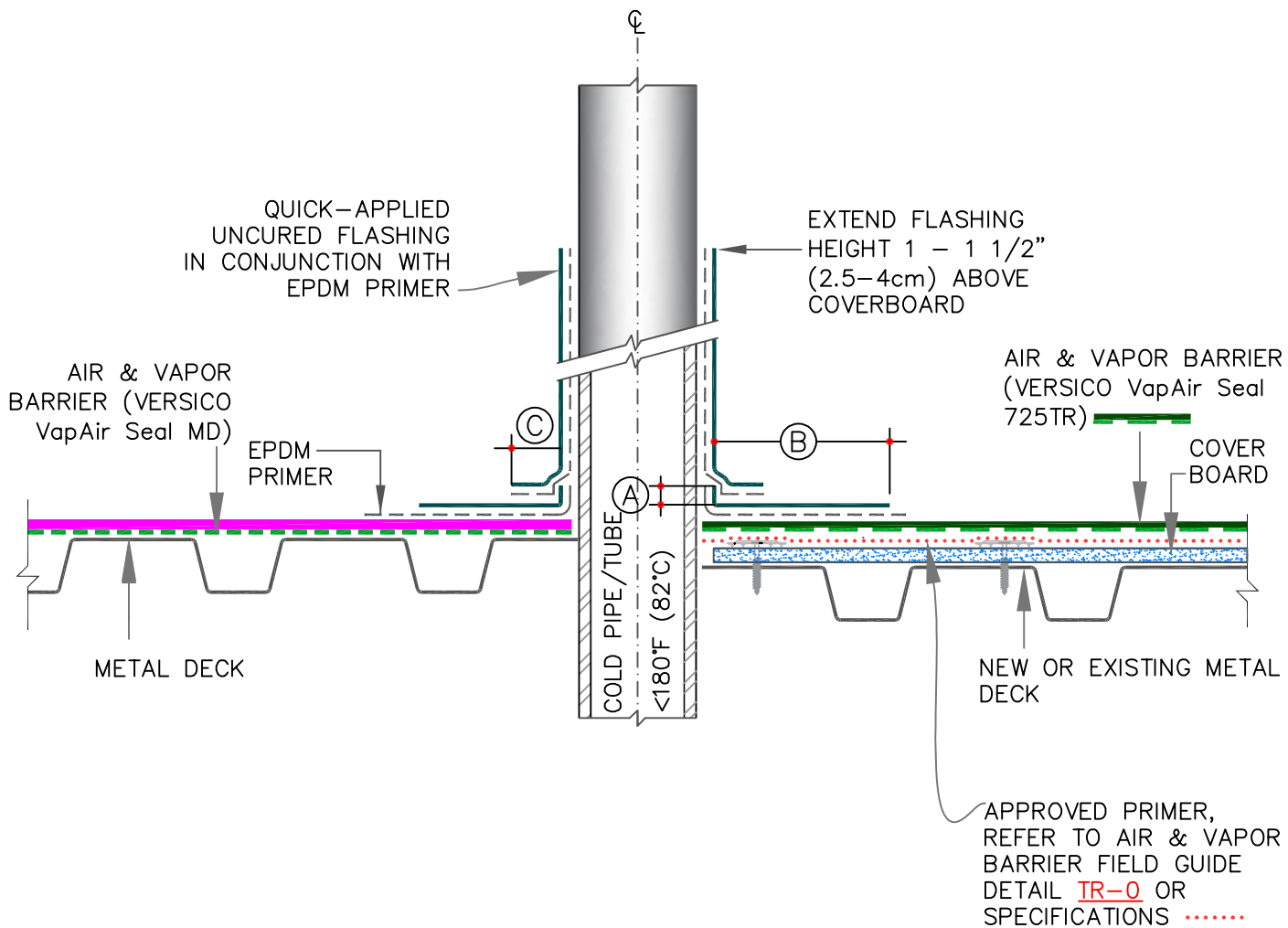

NOTE:

- FOR ADDITIONAL INFORMATION, REFER TO VERSICO THERMOSET DETAIL [VGC-8.2](#).

DIMENSIONS		cm	
(A)	1/2"	1.5	MIN.
(B)	5.5"	14	MIN.
(C)	1"	2.5	MIN.

See sheets [V-0.1](#) to [V-0.7](#) & Specs for additional information



PIPE/STRUCTURAL STEEL TUBE THROUGH METAL DECK OPTION A

- NEW MEMBRANE
- - - - - EXISTING MEMBRANE
- INSULATION
- 0 SEE NOTE(S)

VENT SECURED ROOFING SYSTEM

V-8.1

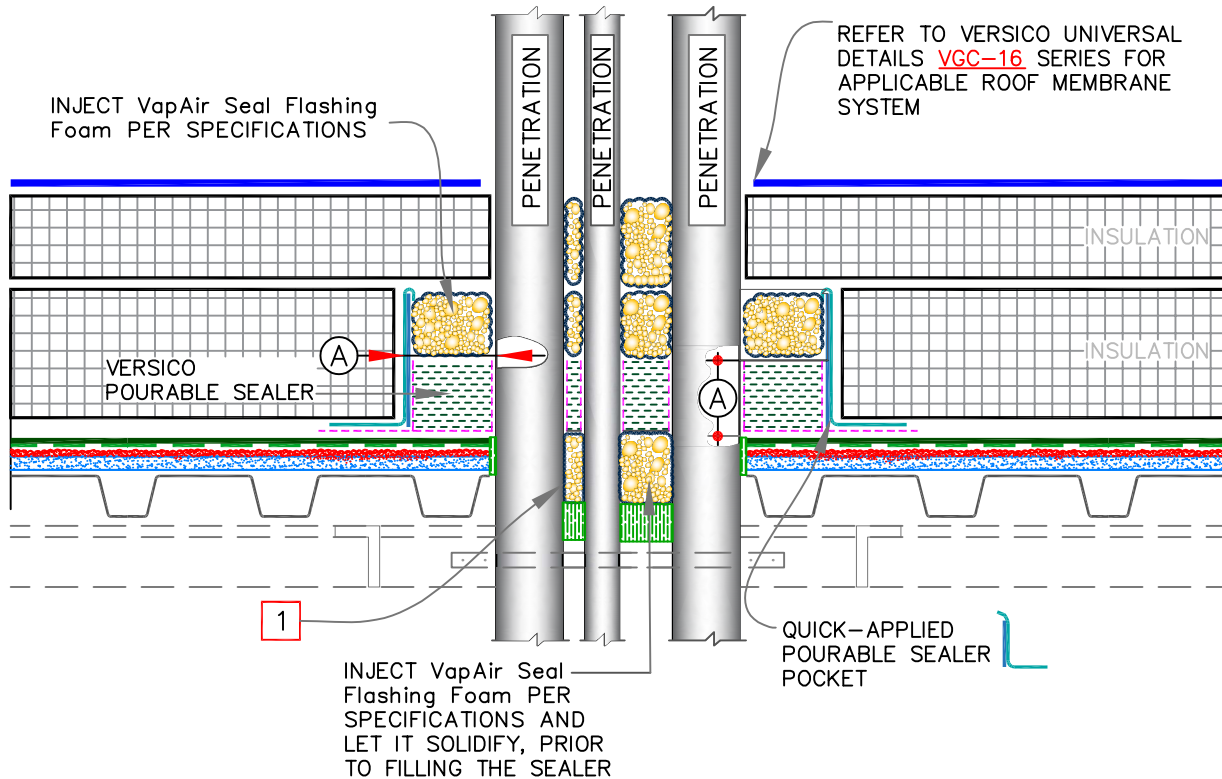

DIMENSIONS		cm	
Ⓐ	1/2"	1.5	TO
	1"	2.5	

NOTES:

1. THE MAXIMUM ALLOWABLE SURFACE TEMPERATURE OF THE PENETRATION SHALL NOT EXCEED 180° F (82° C).
2. PENETRATIONS, AIR & VAPOR BARRIER, FLASHING AND METAL (INSIDE POCKET) MUST BE PRIMED WITH EPDM PRIMER PRIOR TO APPLYING POURABLE SEALER. DO NOT PRIME THE BLUE PLASTIC SUPPORT STRIP.
3. POURABLE SEALER MUST CONTACT PRIMED QUICK-APPLIED UNCURED EPDM FLASHING AND AIR & VAPOR BARRIER.
4. PIPE CLUSTERS MUST HAVE MINIMUM 1" (2.5cm) CLEARANCE BETWEEN PENETRATIONS.

See sheets [V-0.1](#) to [V-0.7](#) & Specs for additional information



MULTIPLE PENETRATIONS THROUGH STEEL DECK – NEW CONSTRUCTION

- NEW MEMBRANE
- EXISTING MEMBRANE
- INSULATION
- 0 SEE NOTE(S)

VENT SECURED ROOFING SYSTEM

V-8.2

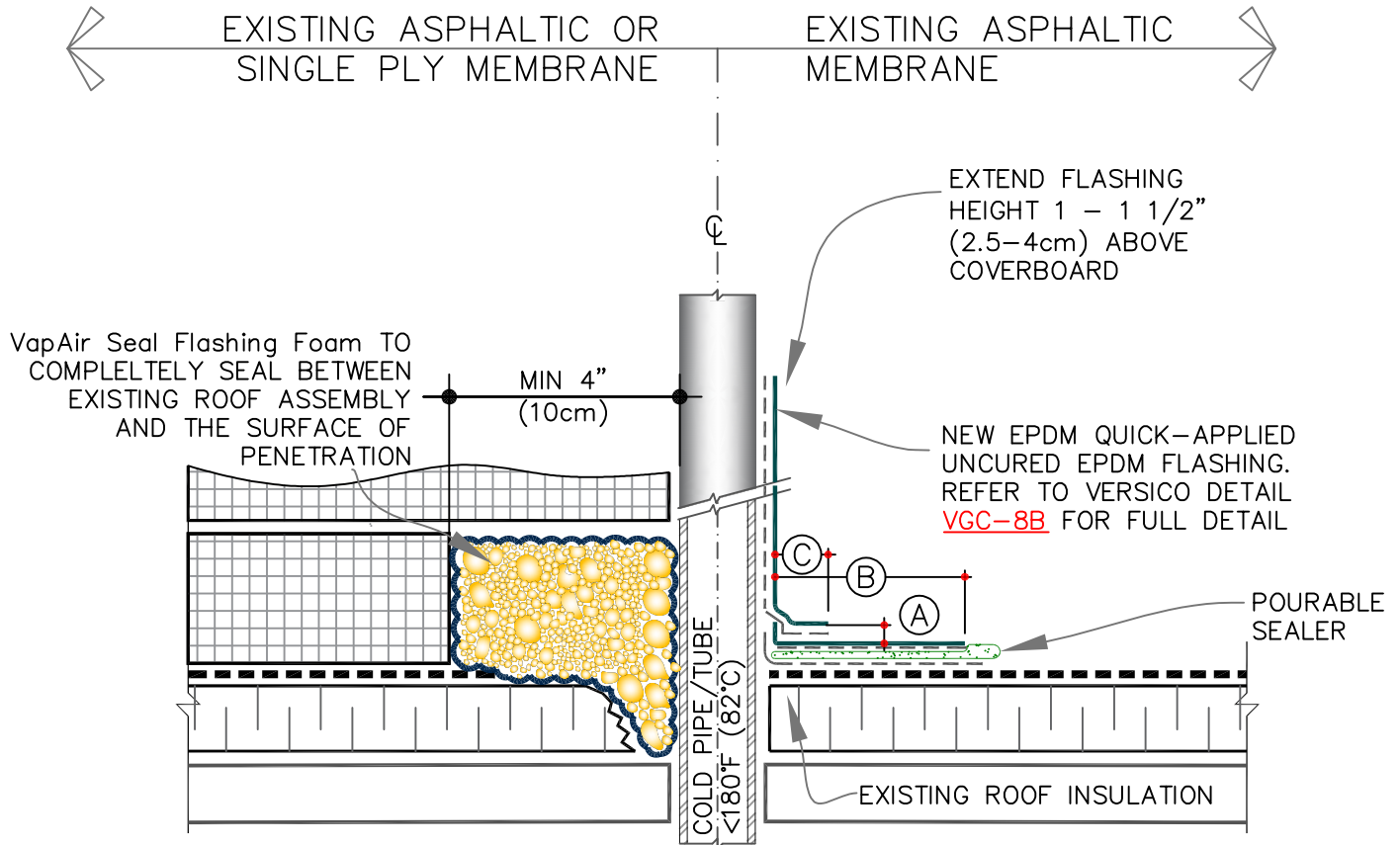

DIMENSIONS		cm	
(A)	1/2"	1.5	MIN.
(B)	5.5"	14	MIN.
(C)	1"	2.5	MIN.

See sheets [V-0.1](#) to [V-0.7](#) & Specs for additional information



SINGLE PENETRATION THROUGH EXISTING ROOF ASSEMBLY

- NEW MEMBRANE
- EXISTING MEMBRANE
- INSULATION
- 0 SEE NOTE(S)

VENT SECURED ROOFING SYSTEM

V-8.3

NOTES:

1. APPLY NEW SEALANT AT ALL CRACKED AND BREACHED AREAS OF POURABLE SEALERS. ENSURE A PROPER BOND BETWEEN EXISTING MATERIAL AND THE PENETRATIONS
2. FILL VOIDS AROUND NEW INSULATION WITH FOAM.

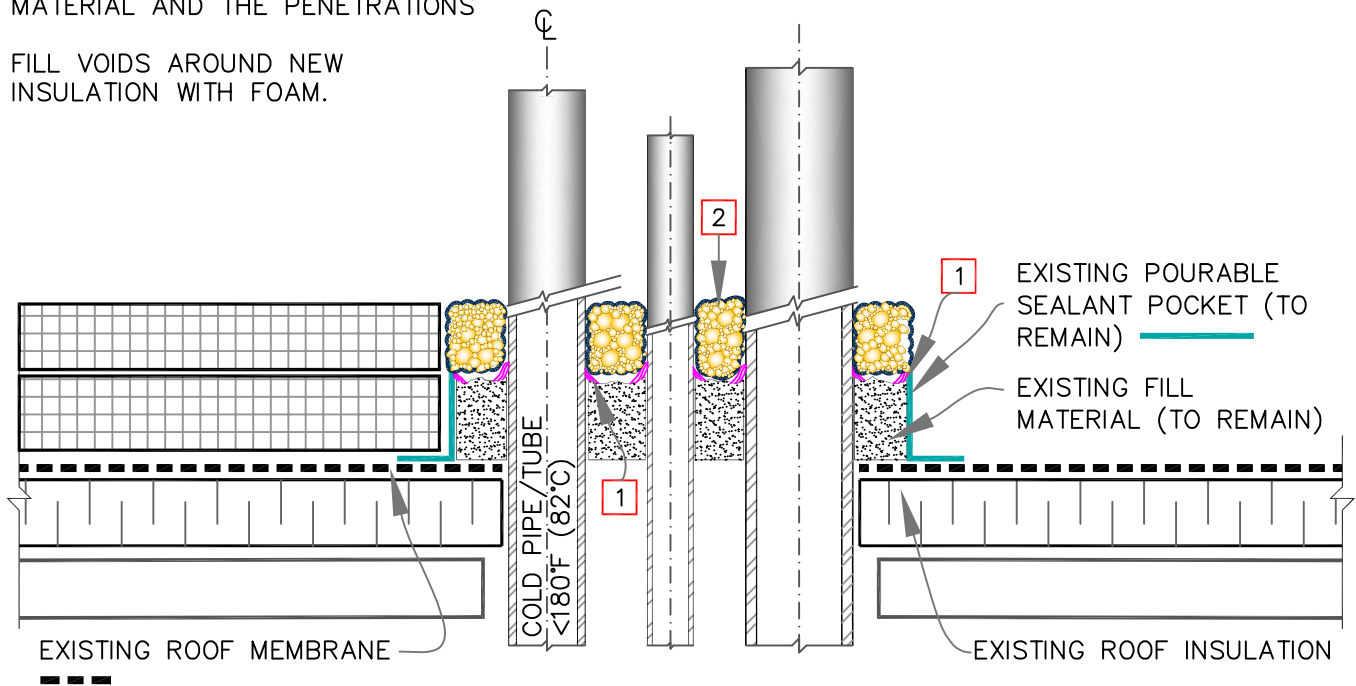

See sheets [V-0.1](#) to [V-0.7](#) & Specs for additional information



CLUSTER OF PENETRATIONS THROUGH EXISTING ROOF ASSEMBLY		NEW MEMBRANE
		EXISTING MEMBRANE
		INSULATION
		SEE NOTE(S)

VENT SECURED ROOFING SYSTEM
V-8.4

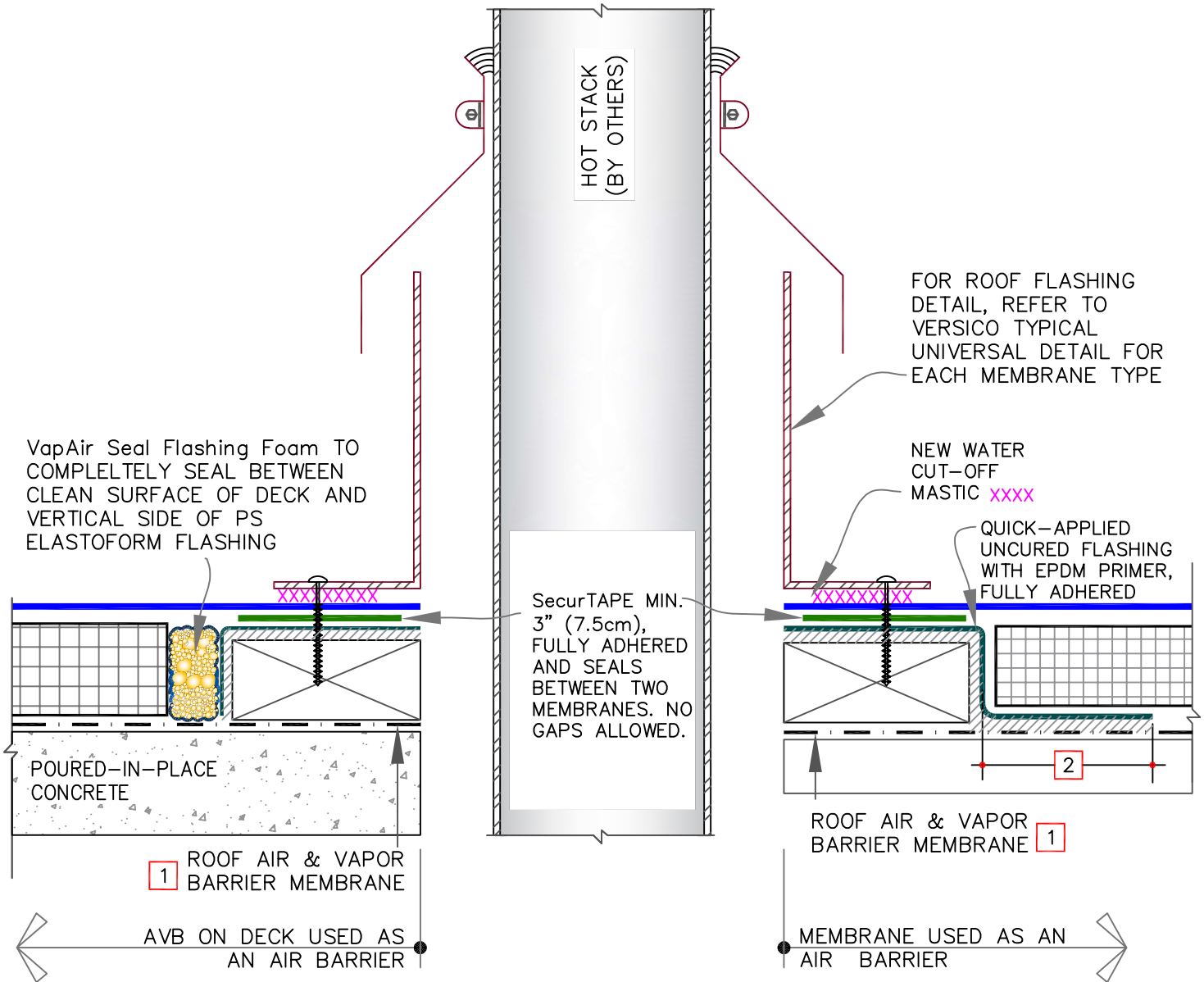

NOTES:

1. ON STEEL DECKS DIRECTLY ADHERE VapAir Seal MD. USE VapAir Seal 725TR ON CONCRETE & WOOD DECKS OR DECKS WITH APPROVED COVER BOARDS.
2. OVERLAP MIN. 6" (15cm) AND FULLY ADHERE TO CREATE AN AIR SEAL.

See sheets [V-0.1](#) to [V-0.7](#) & Specs for additional information



HOT STACK AIR FLASHING - OPTION A

	NEW MEMBRANE
	EXISTING MEMBRANE
	INSULATION
	SEE NOTE(S)

VENT SECURED ROOFING SYSTEM

V-8.5A

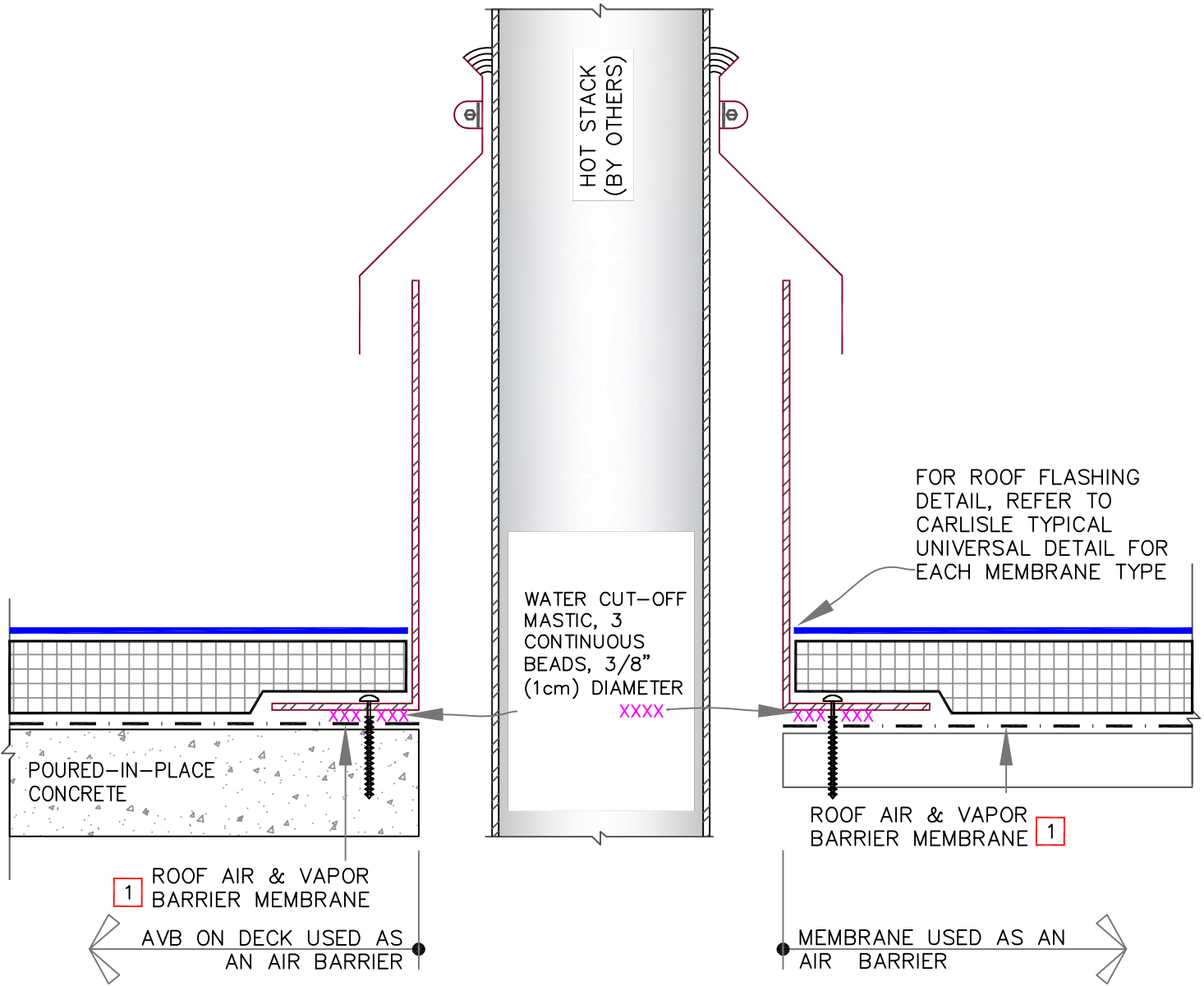

NOTES:

- ON STEEL DECKS DIRECTLY ADHERE VapAir Seal MD. USE VapAir Seal 725TR ON CONCRETE & WOOD DECKS OR DECKS WITH APPROVED COVER BOARDS.

See sheets [V-0.1](#) to [V-0.7](#) & Specs for additional information



HOT STACK AIR FLASHING - OPTION B

	NEW MEMBRANE
	EXISTING MEMBRANE
	INSULATION
	SEE NOTE(S)

VENT SECURED ROOFING SYSTEM

V-8.5B

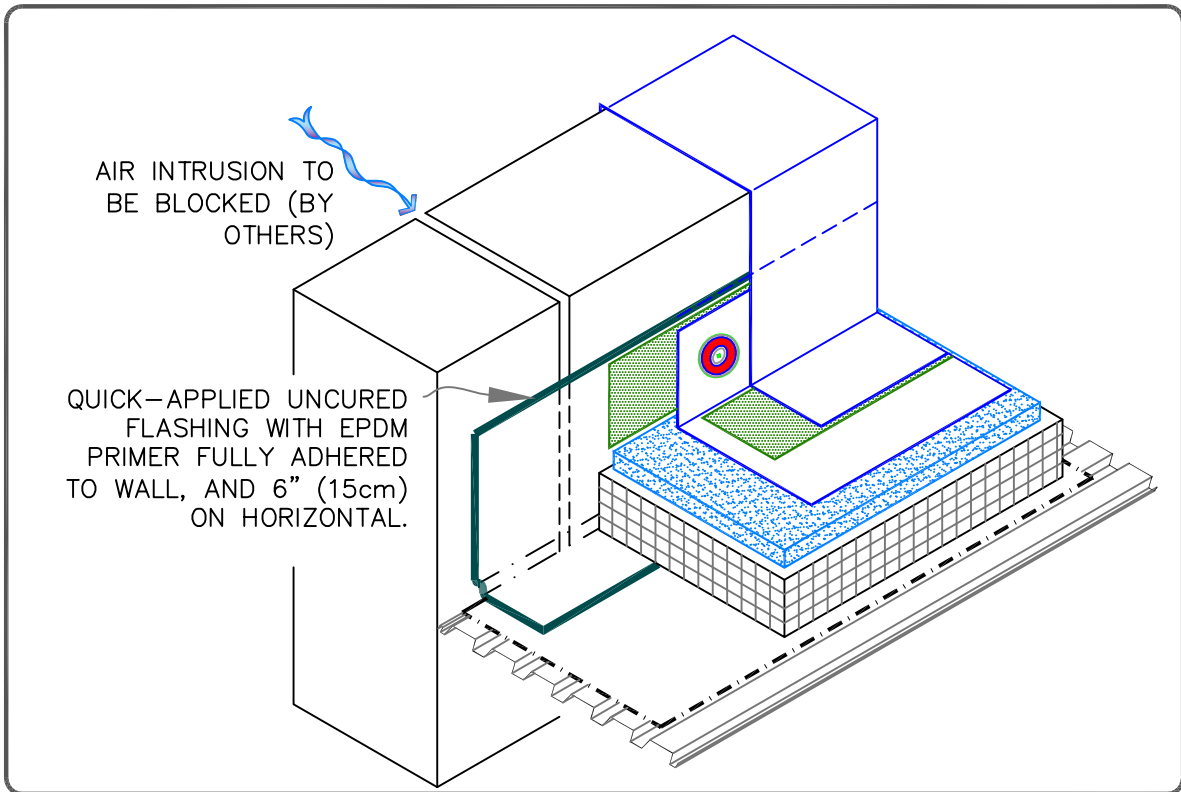
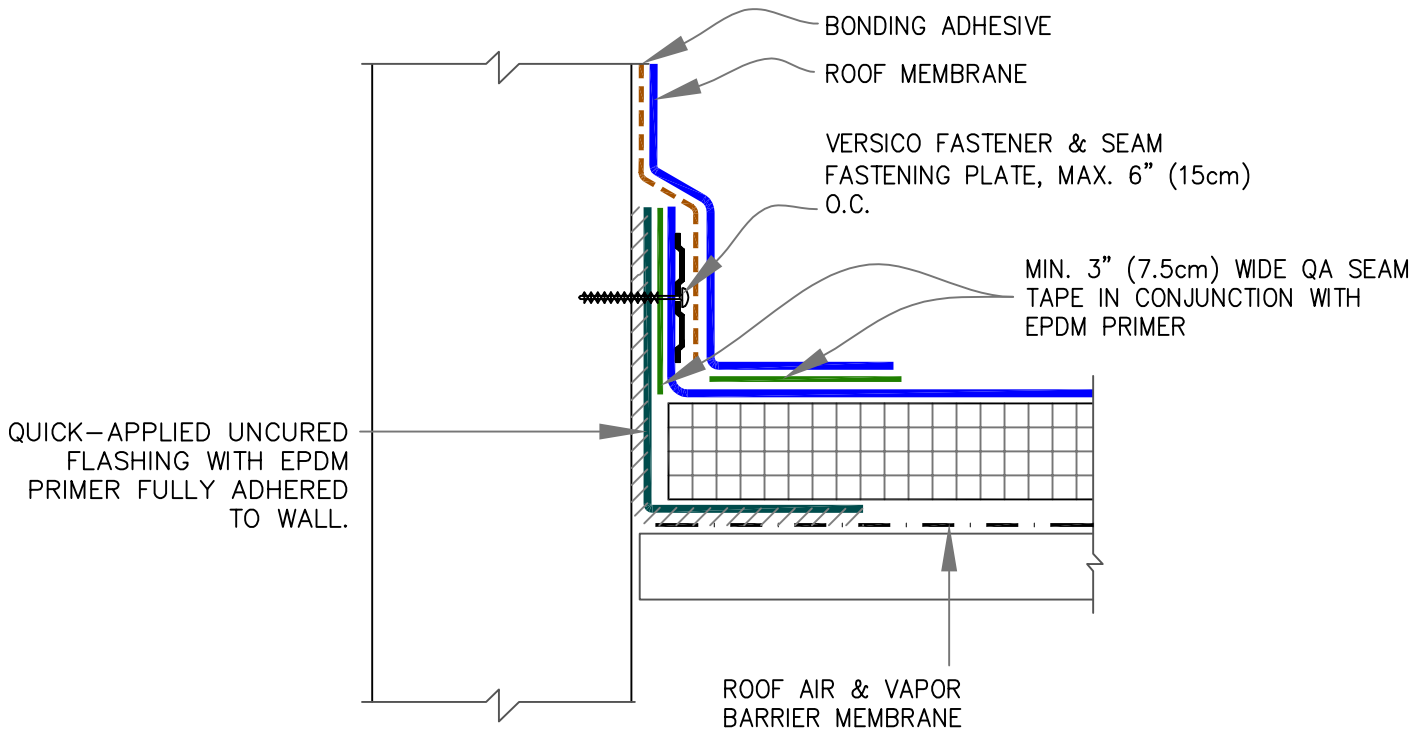

See sheets [V-0.1](#) to [V-0.7](#) & Specs for additional information



PARAPET WITH MEMBRANE AIR BARRIER

- NEW MEMBRANE
- - - - - EXISTING MEMBRANE
- INSULATION
- 0 SEE NOTE(S)

VENT SECURED ROOFING SYSTEM

V-12.1

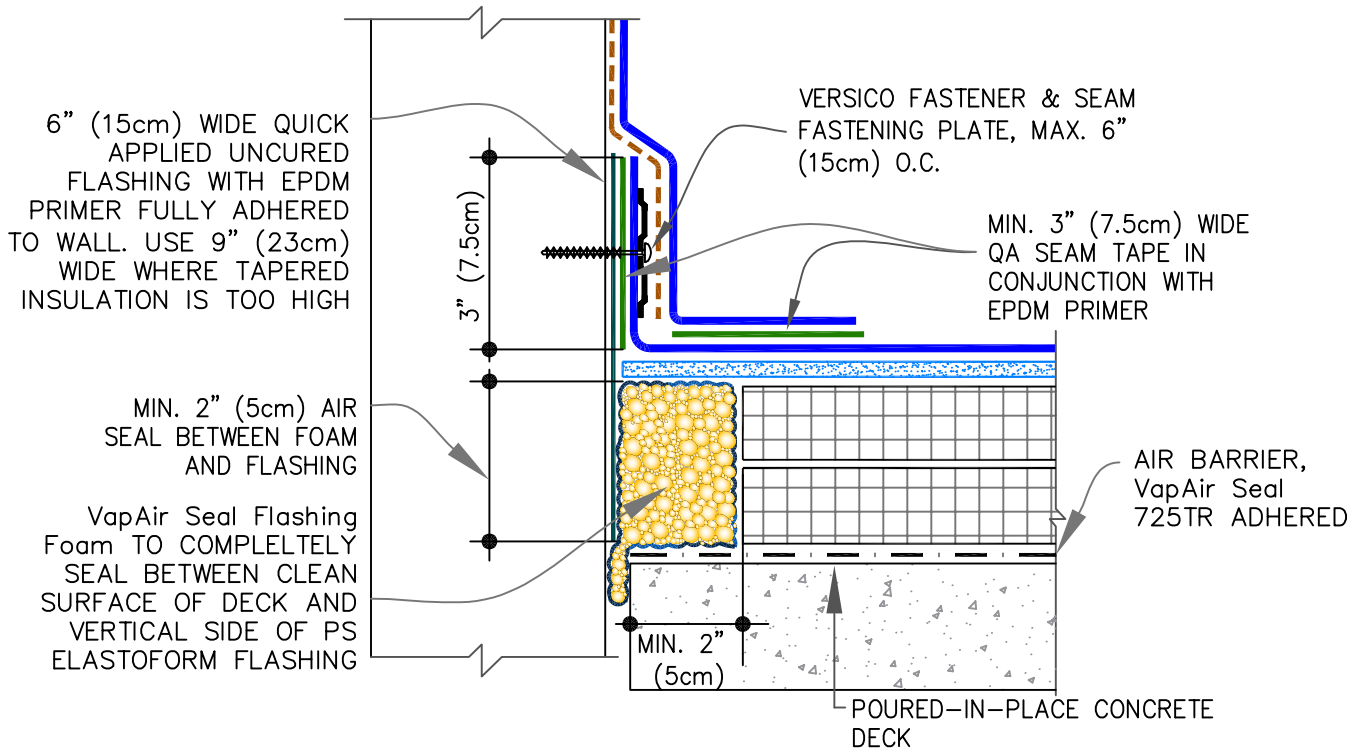

A OPTION: AIR SEALING WITH FOAM

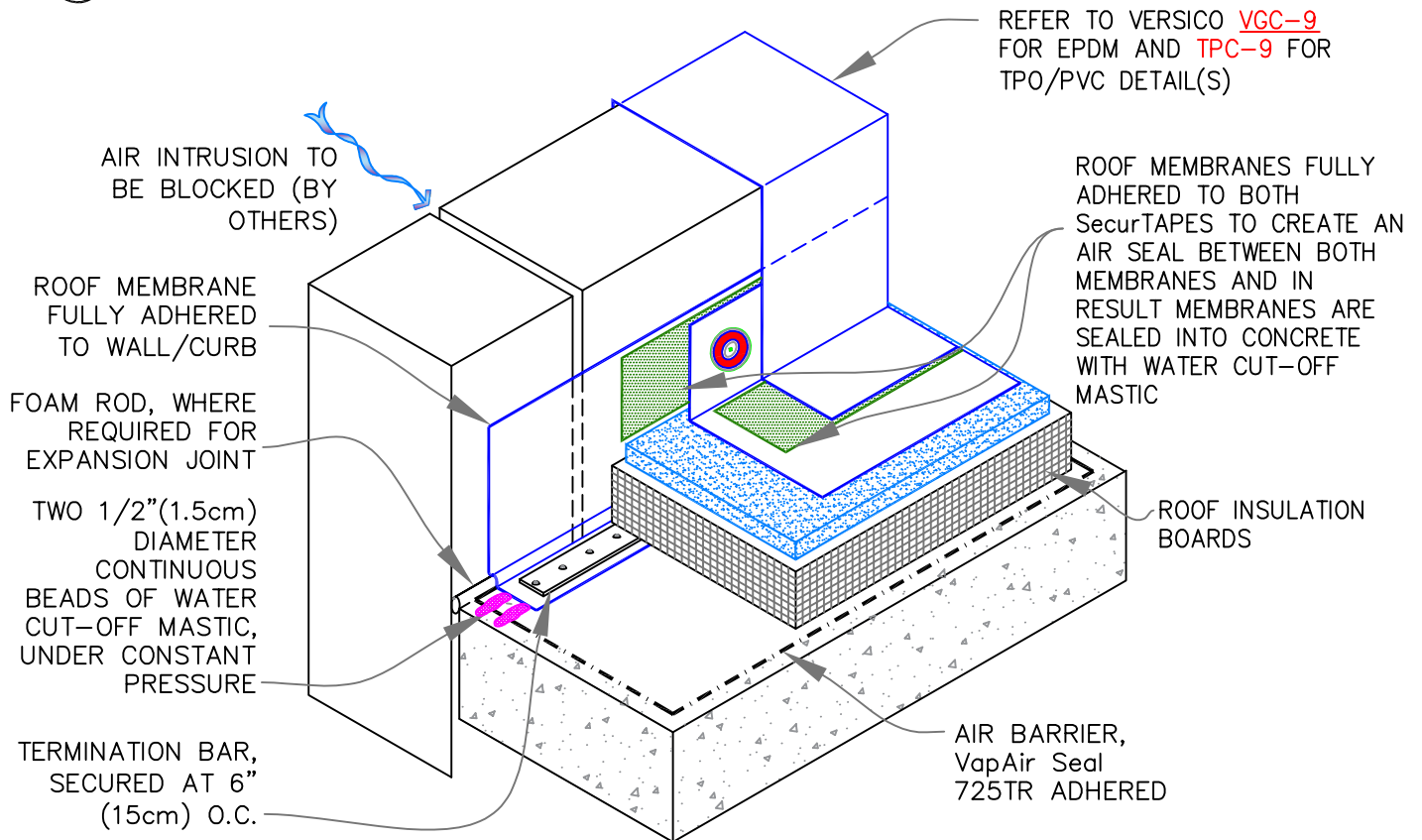

B OPTION: AIR SEALING WITH MEMBRANE FLASHING

See sheets [V-0.1](#) to [V-0.7](#) & Specs for additional information



PARAPET / CURB:
CONCRETE/LIGHTWEIGHT
CONCRETE USED AS AN AIR
BARRIER

	NEW MEMBRANE
	EXISTING MEMBRANE
	INSULATION
	SEE NOTE(S)

VENT SECURED
ROOFING SYSTEM

V-12.2

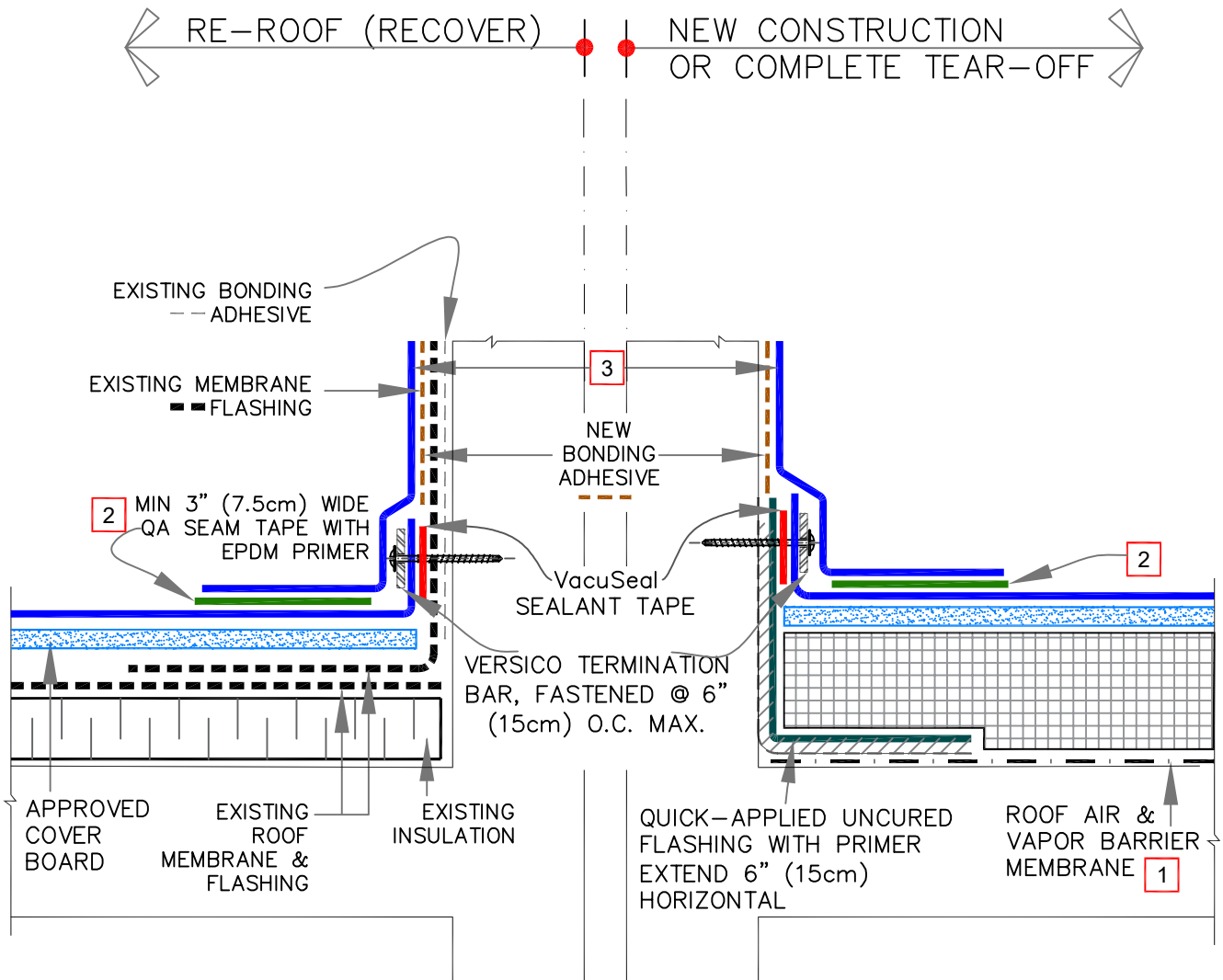

NOTES:

1. ON STEEL DECKS DIRECTLY ADHERE VERSICO VapAir Seal MD. USE VERSICO VapAir Seal 725TR ON CONCRETE & WOOD DECKS OR DECKS WITH APPROVED COVER BOARDS.
2. FOR ADDITIONAL INFORMATION, REFER TO VERSICO'S THERMOSET DETAIL [VGC-5.1](#) FOR EPDM AND THERMOPLASTIC DETAIL [TPC-5.1](#) FOR TPO/PVC.
3. SELF-ADHERING EPDM CURB WRAP MAY BE SUBSTITUTED AS FLASHING ON EPDM ROOFS.

See sheets [V-0.1](#) to [V-0.7](#) & Specs for additional information



PARAPET OR WALL – NEW CONSTRUCTION AND RE-ROOF (RECOVER)	<table border="0"> <tr> <td style="border: 1px solid black; width: 20px; height: 10px; background-color: blue;"></td> <td>NEW MEMBRANE</td> </tr> <tr> <td style="border: 1px solid black; width: 20px; height: 10px; background-color: black;"></td> <td>EXISTING MEMBRANE</td> </tr> <tr> <td style="border: 1px solid black; width: 20px; height: 10px; background-image: linear-gradient(to right, black 1px, transparent 1px), linear-gradient(to top, black 1px, transparent 1px); background-size: 4px 4px;"></td> <td>INSULATION</td> </tr> <tr> <td style="border: 1px solid black; width: 20px; height: 10px; text-align: center;">0</td> <td>SEE NOTE(S)</td> </tr> </table>		NEW MEMBRANE		EXISTING MEMBRANE		INSULATION	0	SEE NOTE(S)
	NEW MEMBRANE								
	EXISTING MEMBRANE								
	INSULATION								
0	SEE NOTE(S)								

VENT SECURED ROOFING SYSTEM V-12.3
--

End of Section

Copyright 2024 Versico

Versico, VersiGard, Flexible DASH and VacuSeal are Trademarks of Versico

This specification represents the applicable information available at the time of its publication. Owners, specifiers and Versico authorized roofing contractors should consult Versico or their Versico Independent Sales Representative for any information, which has subsequently been made available.

Review the appropriate Versico warranty for specific warranty coverage, terms, conditions and limitations.



SPECIFICATION

SUPPLEMENT

G-14-21

DeckVent Roof Assembly for Lightweight Structural Concrete Decks Adhered, Ballasted or Induction Welding Attachment Method

January 2024

The information contained in this supplement serves as a criteria for Specifiers and Authorized Contractors regarding the design and installation of Versico Roofing Systems and use of DeckVent EPS and roof vents for roofing assembly installations over newly poured lightweight structural concrete decks (after achievement of full structural strength) or for retro-fitting (with tear off) over existing structural concrete deck. In addition to the information contained herein, attached details are included to provide the Specifiers and Authorized Contractors with quick access to specific information. Specifiers and Authorized Contractors are advised to reference all applicable details included with this spec supplement.

The assembly described herein includes DeckVent EPS and Versico SecurShield Polyiso or Securshield Polyiso HD, one-way and two-way roof vents, in addition to any of the Versico Single-ply membranes (EPDM, TPO or PVC) (**60-mil thick minimum**).

A. Description

The roofing assembly incorporates the DeckVent EPS insulation directly over lightweight structural concrete deck with the subsequent layer(s) of SecurShield Polyiso Insulation or SecurShield Polyiso HD Cover Board.

With any of the membranes listed below, one-way roof vents are required at the rate of 1 per 2,000 SF and shall be positioned closer to the perimeter and two-way roof vents in the field of the roof at the rate of 1 per 8,000 SF. For projects with individual roof sections less than 2,000 SF, Contact Versico for vent number recommendations, also refer to appropriate detail for recommended locations.

Regardless of the membrane attachment method, Adhered, Induction Welded or Ballasted, a continuous air seal must be provided by sealing any gaps or joints at walls, around penetrations, roof projections and around roof drains. Refer to appropriate detail at the end of this document.

1. Adhered Assemblies – Using EPDM, TPO or PVC, the DeckVent EPS Insulation may be fastened directly to the structural deck at a rate of 1 fastener and plate per 4 SF. With subsequent layers of insulation or coverboard set in Flexible DASH bead adhesive at 6" O.C. The membrane shall be fully adhered using the appropriate bonding adhesive per Versico's Thermoset or Thermoplastic Specification.

NOTE: In lieu of fastening and adhering individual layers of insulation, fasteners may be secured through all layers of insulation directly to concrete deck.

2. Induction Welded Assemblies – Using TPO or PVC, the DeckVent EPS Insulation is overlaid with SecurShield Polyiso or SecurShield Polyiso HD, Versico's CD-10 or MP-14-10 fastener and TPO or PVC Induction Welding Plates are used to secure both layers to the structural deck. The fastening density of the plates and fasteners shall be in compliance the Induction Welding Attachment (Attachment I) of the Thermoplastic Specification.
3. Ballasted Assemblies – This option which is only available with VersiGard EPDM. Loose-lay the DeckVent EPS and the Securshield Polyiso, directly over the concrete deck. If insulation securement is specified (not required for Versico warranty) it must be accomplished by mechanically fastening the DeckVent EPS and adhering the subsequent layer(s) of SecurShield Insulation. Consult the Versico published Specification for Ballasted Roof Assemblies, for additional requirements not listed herein.

Any of the assemblies described herein, using 60-mil membrane, are eligible for a 5, 10, 15 or 20 Year Membrane System Warranty and Warranty wind speed up to 72 mph. For higher wind speed coverage, project may be submitted to Versico for Approval.

NOTE: This system is not for use on Cold Storage/Freezer Buildings. Such projects may be submitted to Versico for other design options.

B. Quality Assurance

1. The specified roofing system must be installed by a Versico Authorized Roofing Contractor in compliance with drawings and specifications as approved by Versico.
2. Do not install this assembly before the concrete deck has reached its' initial structural strength. Project Engineer must be consulted prior to job start-up.

C. Submittals

1. Shop drawings must be submitted to Versico by the Versico Authorized Roofing Contractor along with a completely executed Copy-A Job Approval Request for approval. Approved shop drawings are required for inspection of the roof and on projects where on-site technical assistance is requested.
2. Upon completion of the installed work, submit copies of the manufacturer's final inspection to the specifier prior to the issuance of the manufacturer's warranty.

D. Products

Products listed in "Part II" of the Versico Thermoset/Thermoplastic Roofing System Specification can be used as part of the DeckVent Roofing System.

1. **DeckVent EPS:** A 4' x 4' x 2" thick, closed cell, expanded polystyrene (Type IX - 1.8 pcf (min.) nominal density) board with 5/8" wide channels routed, bi-directionally, on the bottom facer. The 2" thick board has an R-Value of 7.1.
2. **One- and Two-Way Pressure Relief Vent:** Heavy-gauge spun aluminum vent are engineered to reduce moisture within the roofing system and release trapped air pressure within the building. Base diameter 11", Stack diameter at base of 5" and overall height of 8". For identification purposes, One-Way Pressure Relief vent is marked with a single dimple on the top (cap) versus two dimples for the two-way pressure relief vents.
3. **Flexible DASH Adhesive:** A bead-applied, two-component polyurethane, construction grade, low-rise expanding foam adhesive used for attaching approved insulations to other approved insulations and coverboards. Also may be used to fill voids between deck to wall junctions and around pipe penetrations.
4. **VapAir Seal Flashing Foam** – a low pressure foam system that utilizes a non-flammable blowing agent. The foam is used to seal penetrations and reduce air leakage, especially at roof perimeters.
5. **VersiGard (black or white) Quick-Applied Uncured Flashing:** A 6" X 100' and 9" or 12" wide by 50' long, 60-mil thick VersiGard (black) or VersiGard White **uncured** EPDM Flashing laminated to a 30-mil Quick-Applied Tape (QAT) used in conjunction with EPDM/TPO/PVC Primer.

VersiGard/VersiGard White Quick-Applied Uncured Flashing is used to flash one-way and two-way roof vents.

6. **VersiFlex PVC non-reinforced Flashing** is 80-mil thick (white on gray) and available in rolls **12" and 24" wide by 50' long**. Flashing is used for field fabricated flashings for one-way and two-way roof vents.
7. **RhinoBond or Isoweld TPO or PVC Welding Plate**: A 3" diameter, 0.028" thick, corrosion-resistant steel plate with hot melt coating on the top surface. The plate is used in conjunction with Versico's HP-X Fasteners to attach the roofing assembly and is activated using the RhinoBond or Isoweld Induction Welding Tool.
8. **VersiGard or VersiGard White Quick Applied (QA) Seam Tape**: A 3" or 6" wide by 100' long splice tape used for attaching the one-way and two-way roof vents to the membrane before flashing the vent.
9. For other products needed to complete roof assembly, SecurShield Polyiso and Securshield Polyiso HD, refer to listings in Part II of the Thermoset and Thermoplastic Specification.

E. Execution

Follow current specifications for installing roof membranes and seaming per specific membrane. [VersiGard (EPDM), VersiWeld (TPO) or VersiFlex (PVC)].

1. General

- a. When feasible, begin the application at the highest point of the highest roof level and work to the lowest point to prevent moisture infiltration and minimize construction traffic on completed sections. This will include completion of all flashings and terminations.

2. Roof Deck Criteria and Preparation

- a. Roofing Assembly described herein intended for use on newly poured structural concrete decks (normal and lightweight) once they have reached their designed structural strength.
- b. Surface imperfections, fins or cracks, must be documented and reported to the specifier, general contractor and building owner for assessment. The Versico Authorized Roofing Contractor shall not proceed unless the defects are corrected.
- c. The substrate must be free of debris, foreign materials and must be free of accumulated water, ice, snow or frost.
- d. Cracks or voids in the substrate greater than 1/4" must be filled with Flexible DASH Adhesive, VapAir Seal Flashing Foam or urethane sealant (by others).
- e. For Deck-to-Wall Junctions and roof penetrations, fill gap with foam backer rod and Flexible DASH Adhesive, VapAir Seal Flashing Foam or urethane sealant (by others). Refer to [Detail MM-2](#).

F. Installation

1. Follow guidelines above for the installation and air sealing of roof deck perimeters and penetrations.
2. Proceed with installation roofing system as described in this section and in accordance with Versico published Specifications for the specific membrane type.
3. After installation of the roofing membrane, mark locations for one-way and two-way roof vents. And cut a 5" diameter core through membrane and insulating material down to the concrete deck. Remove excess material.
4. Place the One-Way and Two-Way Roof Vents centered over void. Follow applicable details depending on type of membrane used. Flash One-Way and Two-Way Roof Vent per requirements outlined in the detail.
5. Repeat procedure at each vent location to comply with the required number of vents needed.
6. Complete all other flashing details per specification for membrane type used, refer to Versico published

specifications.

G. Associated Installation Details

Roof Assemblies Page 1 DV-1
Roof Assemblies Page 2 DV-2
Roof Assemblies Page 3 DV-3
Air Seal Detail: Roof-To-Wall & Pipe Penetration DV-4
Vent Flashing Adhered or Induction Welded Assemblies DV-5
Vent Flashing for Ballasted EPDM Assembly DV-6
Roof Plan – Typical Layout of Vents DV-7
3D Roof Plan – Typical Layout of Vents DV-8
Primary Vent (VacuSeal Vent – Concrete Level)..... DV-9
Secondary Vent (VacuSeal Vent – Membrane Level) DV-10

End of Section

Copyright 2024 Versico Roofing Systems
Versico, DeckVent, VersiGard, VersiWeld and VeriFlex are Trademarks of Versico Roofing Systems

This specification represents the applicable information available at the time of its publication. Owners, specifiers and Versico Authorized Roofing Contractors should consult Versico or their Versico Manufacturer's Representative for any information, which has subsequently been made available.

Review the appropriate Versico warranty for specific warranty coverage, terms, conditions and limitations.

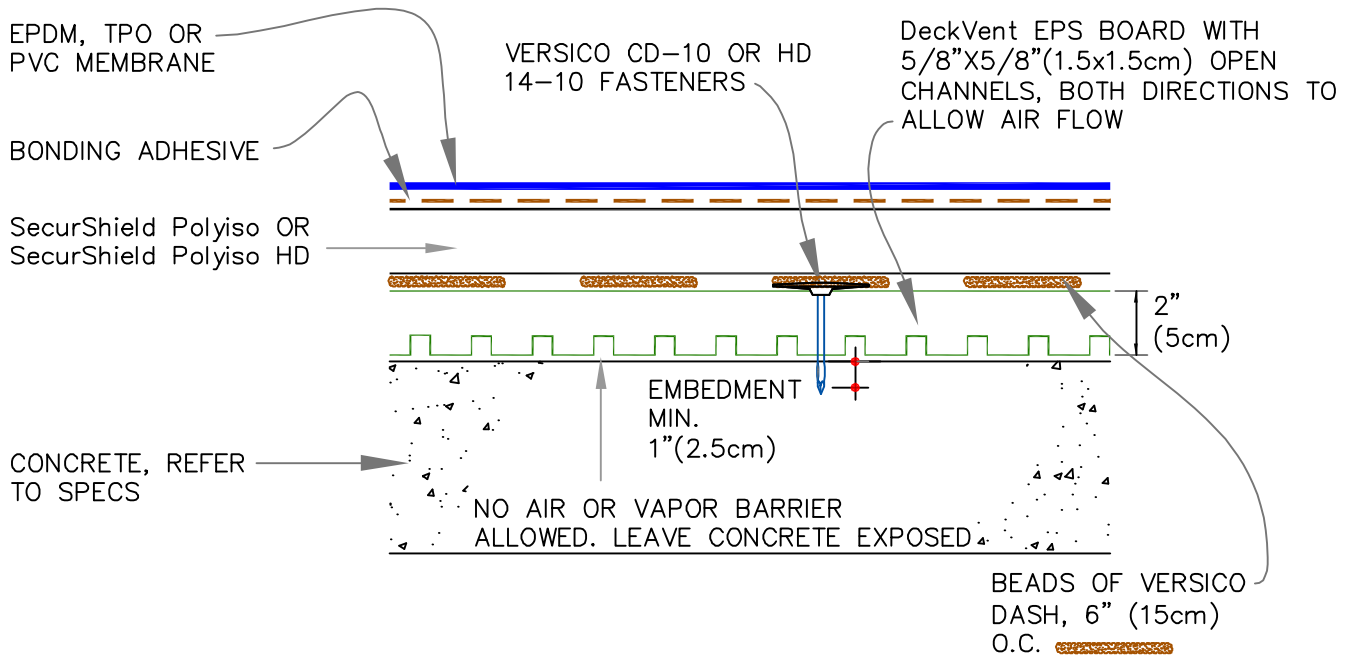

A FULLY ADHERED ROOF
MECHANICALLY FASTENED BOTTOM LAYER ONLY

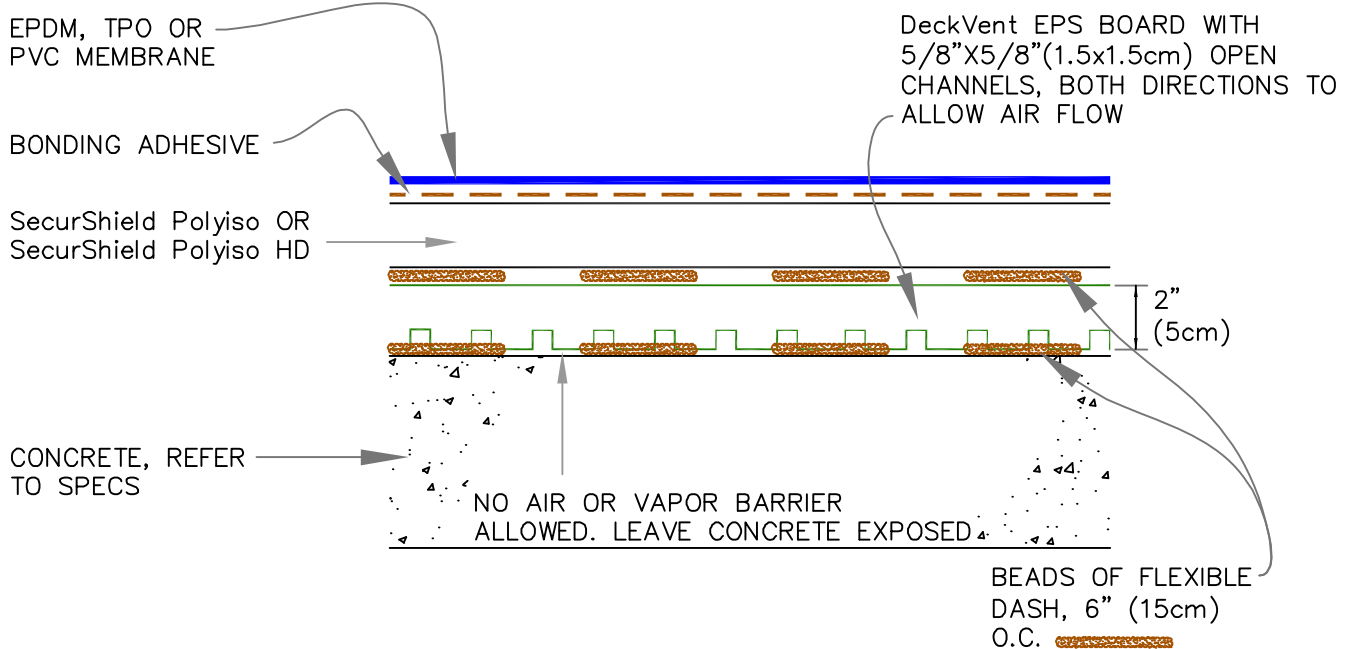

B FULLY ADHERED ROOF

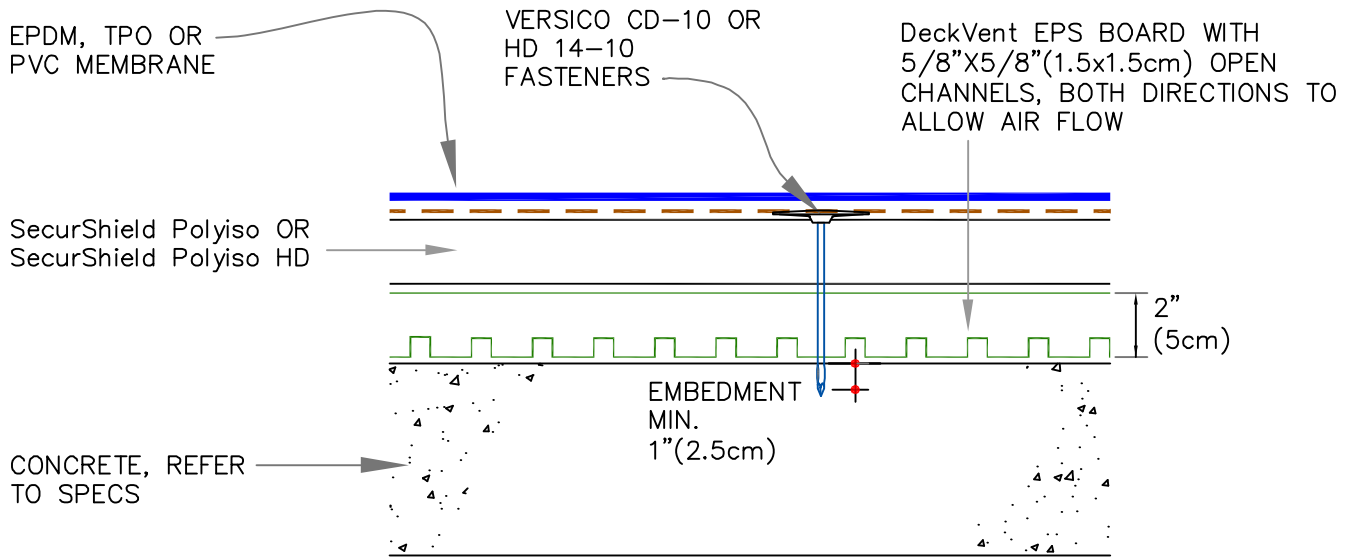

C FULLY ADHERED ROOF MECHANICALLY FASTENED ALL LAYERS

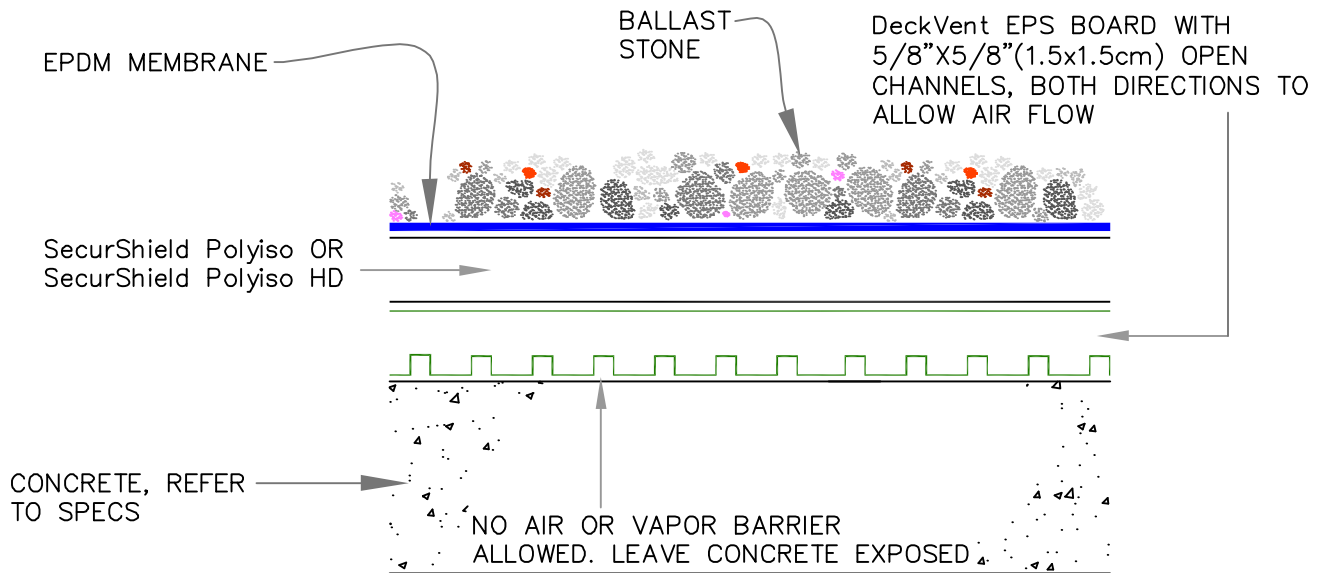

D BALLASTED EPDM ASSEMBLY

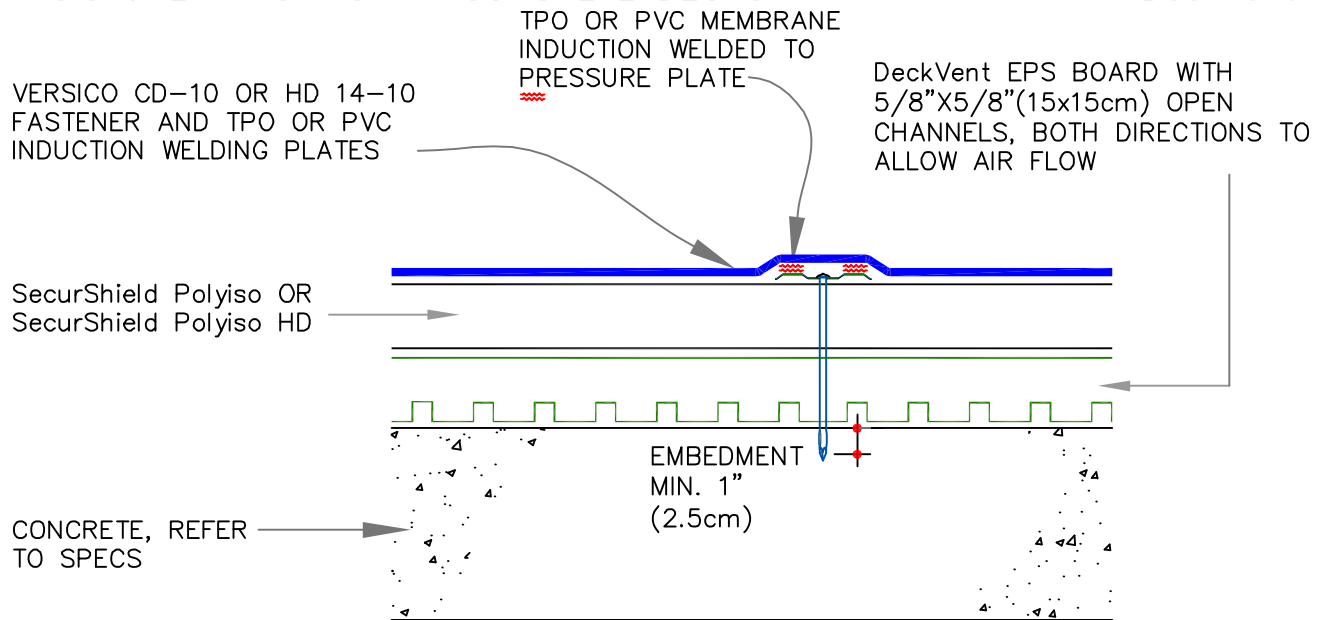

E TPO OR PVC INDUCTION WELDED ASSEMBLY

NOTE:

1. ENSURE CONCRETE EDGES ARE DRY, PRIOR TO SEALANT INSTALLATION.

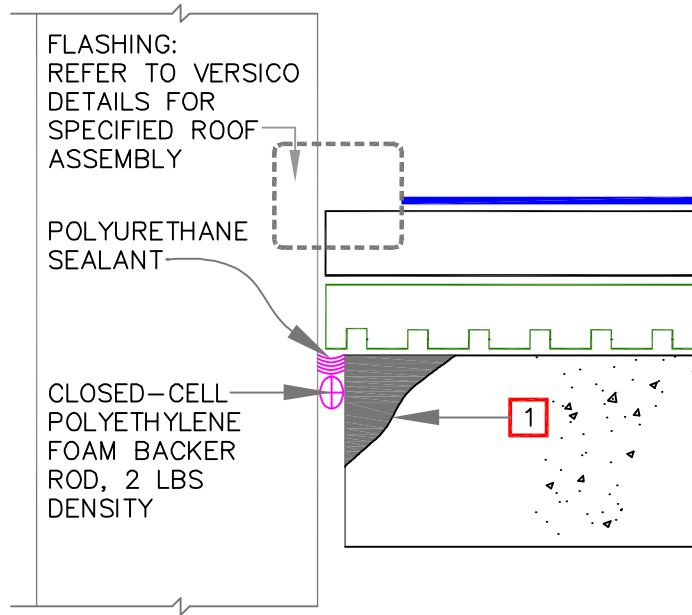

A AIR SEAL : ROOF-TO-WALL

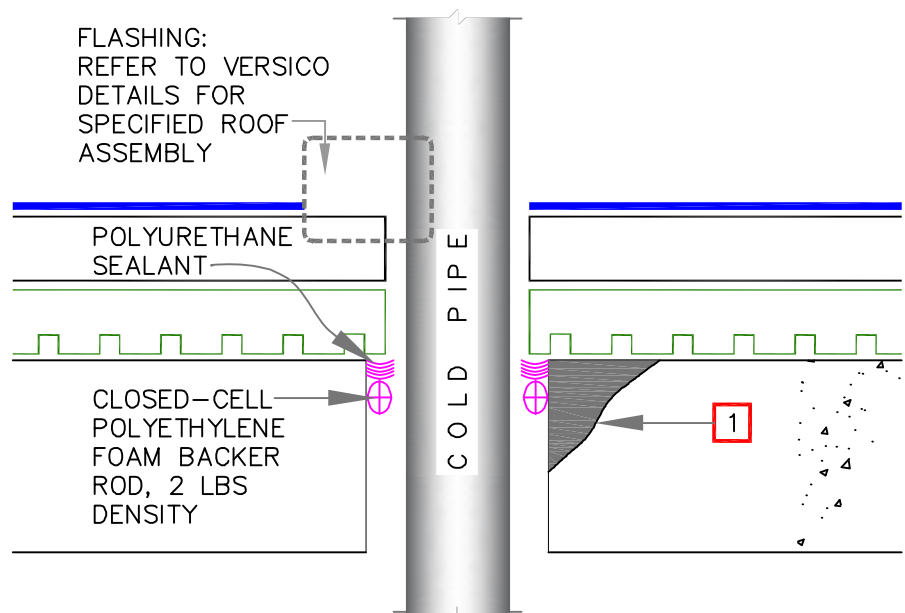

NOTE:

1. ENSURE CONCRETE EDGES ARE DRY, PRIOR TO SEALANT INSTALLATION.

B AIR SEAL : PIPE PENETRATION



AIR-SEAL DETAIL:
ROOF-TO-WALL & PIPE
PENETRATION

— ROOF MEMBRANE
0 — SEE NOTE(S)

DeckVent

DV-4

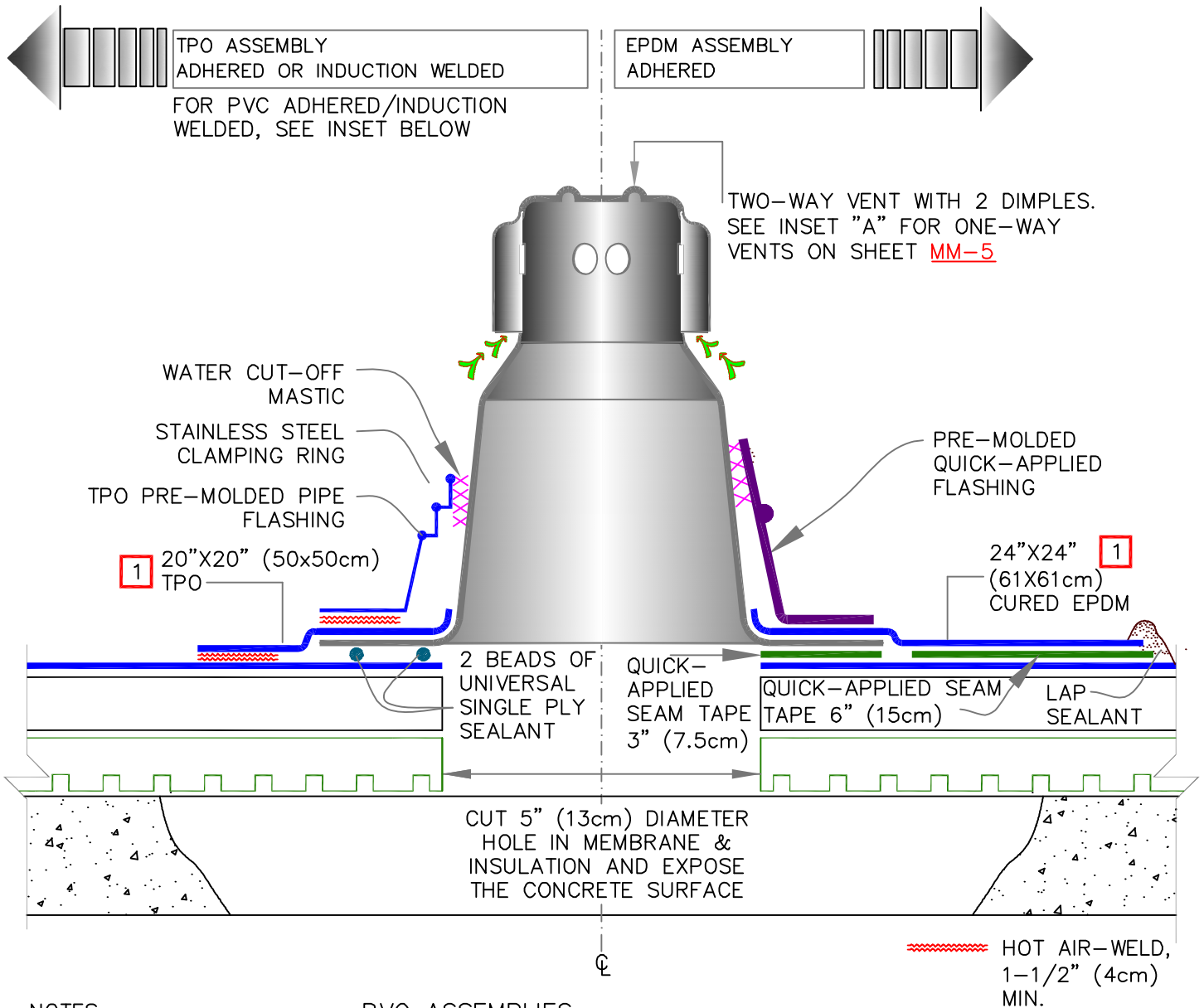

NOTES:

1. CUT SQUARE PIECE, TRIM ROUNDED EDGES, DRAW CENTER LINES AND CUT A 5-1/2" (14cm) DIAMETER HOLE AT THE CENTER OF PIECE. SLIDE THE PIECE THROUGH THE VENT.
2. PRIMER MUST BE APPLIED ON ALL SURFACES PRIOR TO ADHESION OF QUICK-APPLIED FLASHING.

PVC ASSEMBLIES ADHERED OR INDUCTION WELDED

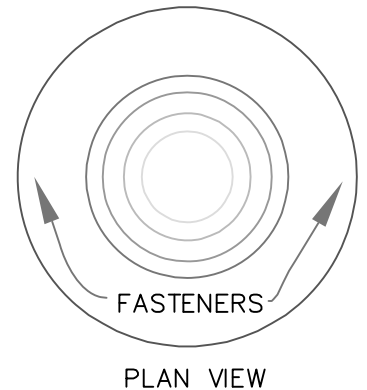
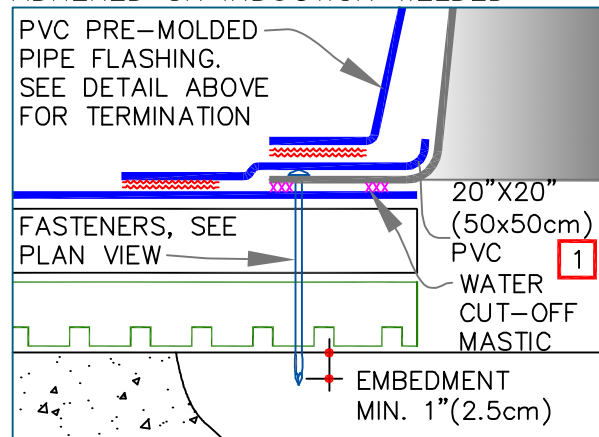

VENT FLASHING ADHERED OR INDUCTION WELDED ASSEMBLIES

0 → ROOF MEMBRANE
1 → SEE NOTE(S)

DeckVent

DV-5

NOTES:

1. TRIM ROUNDED EDGES, DRAW CENTER LINES AND CUT A 5-1/2" (14cm) DIAMETER HOLE AT THE CENTER OF PIECE. SLIDE THE PIECE THROUGH THE VENT.
2. PRIMER MUST BE APPLIED ON ALL SURFACES PRIOR TO ADHESION OF QUICK-APPLIED FLASHING.

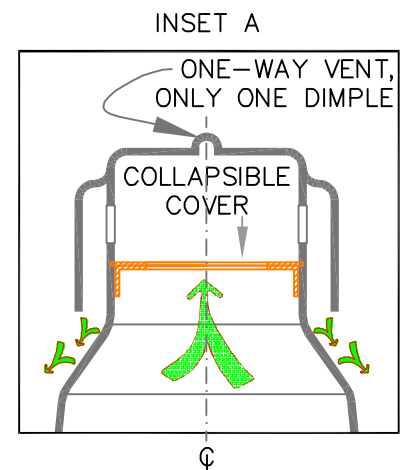
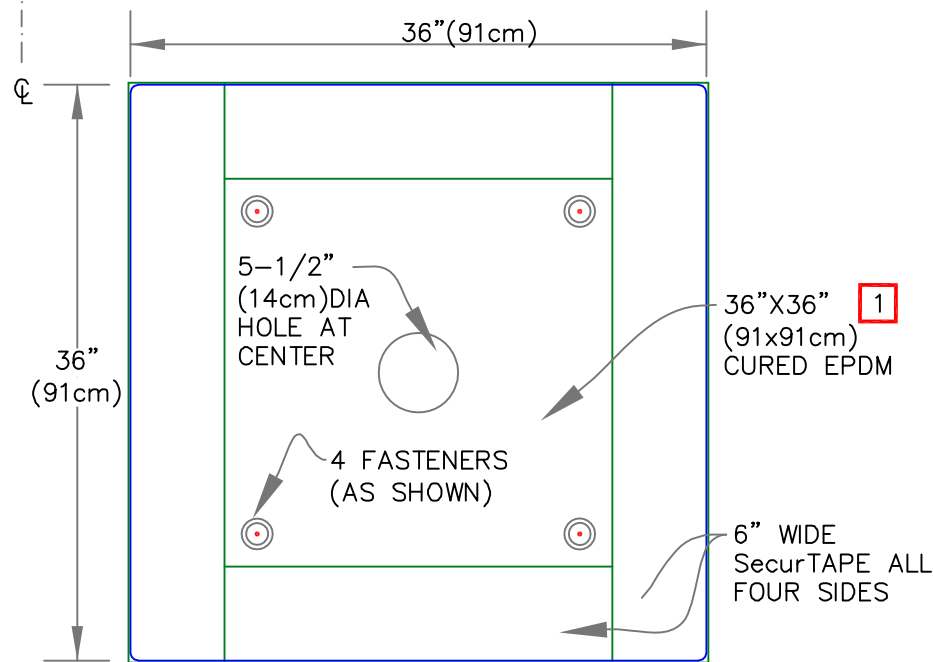
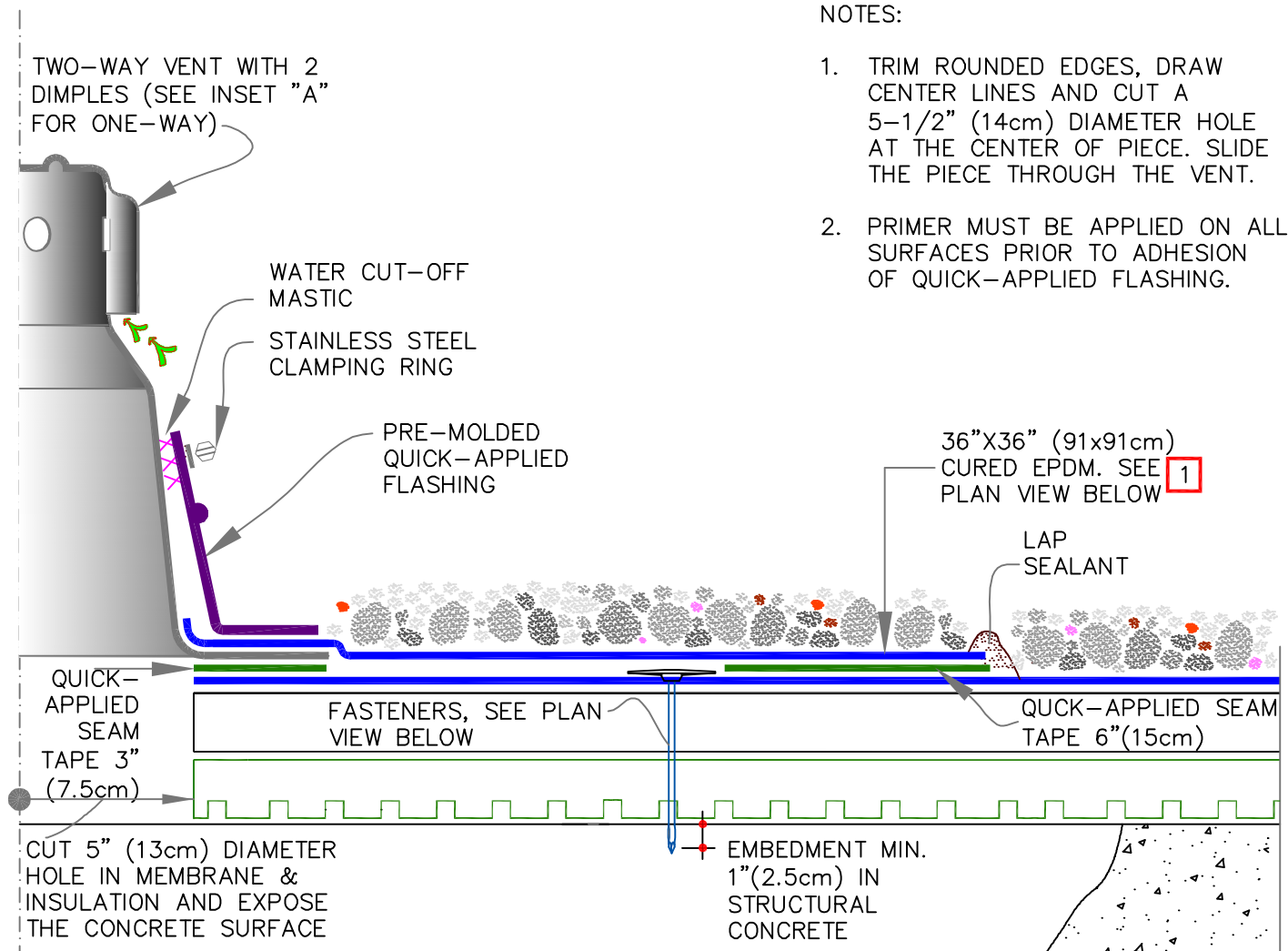

VENT FLASHING FOR BALLASTED EPDM ASSEMBLY

[0] → ROOF MEMBRANE

[1] → SEE NOTE(S)

DeckVent

DV-6

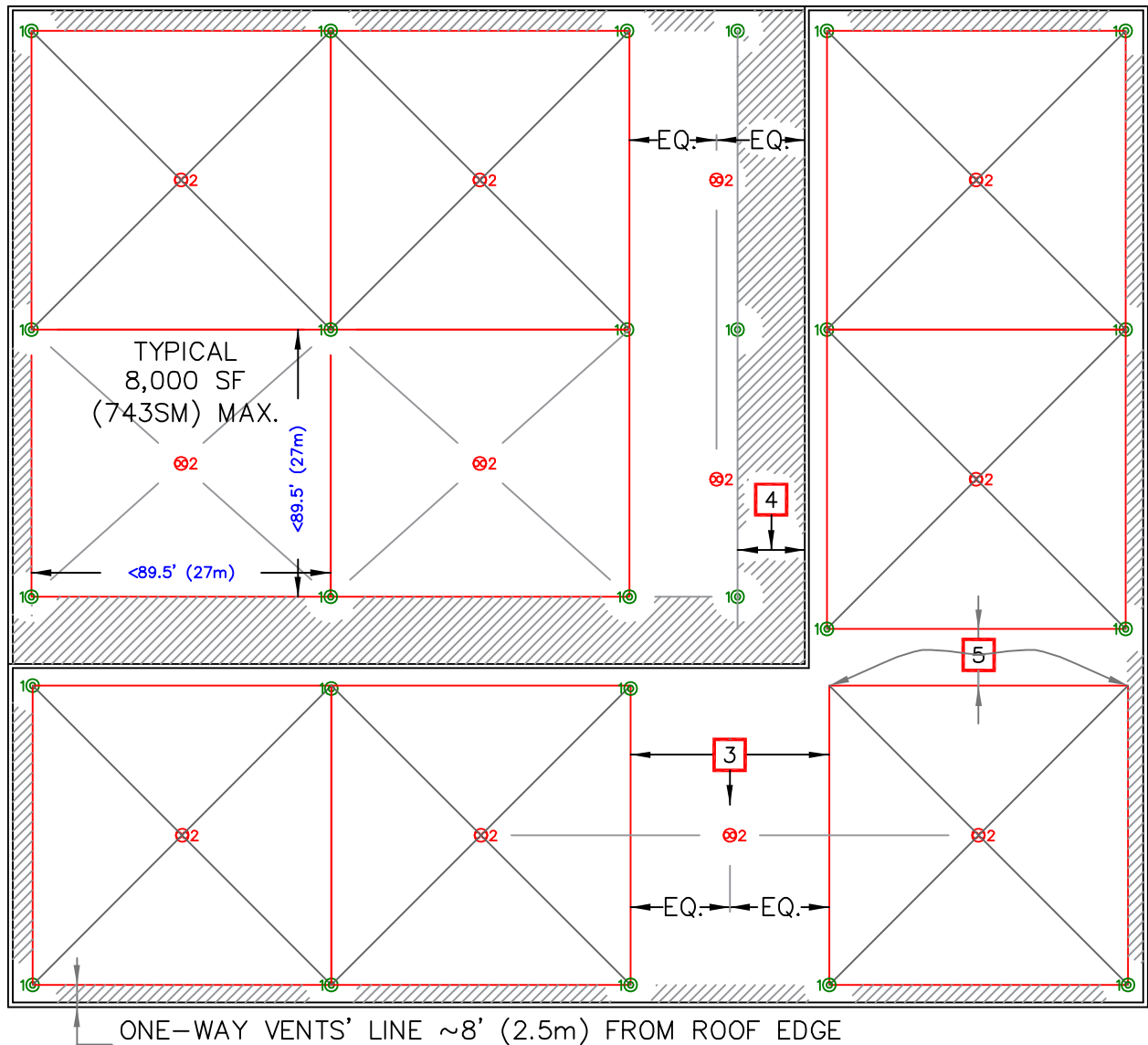

4

NOTES:

1. ONE-WAY VENTS: ONE EACH FOR 2,000 S.F. (186 S.M) MAX.
2. TWO-WAY VENTS: ONE EACH FOR 8,000 S.F. (743 S.M.) MAX.
3. ADD TWO-WAY VENT UNLESS THIS DIMENSION IS LESS THAN 8' (2.5m)
4. WHEN THERE IS A TALL WALL OR HIGHER BUILDING (SEE KEY PLAN), THEN THE ONE-WAY VENTS' LINE SHOULD BE POSITIONED ~16' (4.9m) FROM HIGH WALL
5. SKIP VENT(S), IF LESS THAN 8' (2.5m)

- ⊙ ONE-WAY VENT
- ⊗ TWO-WAY VENT
- CENTER LINE
- ▨ DISTANCE FROM EDGE
- EQ. EQUAL

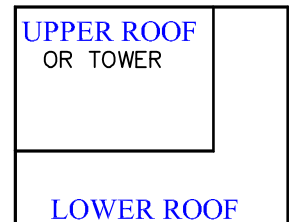

BUILDING KEY PLAN



ROOF PLAN – TYPICAL LAYOUT OF VENTS

— ROOF MEMBRANE

0 — SEE NOTE(S)

DeckVent

DV-7

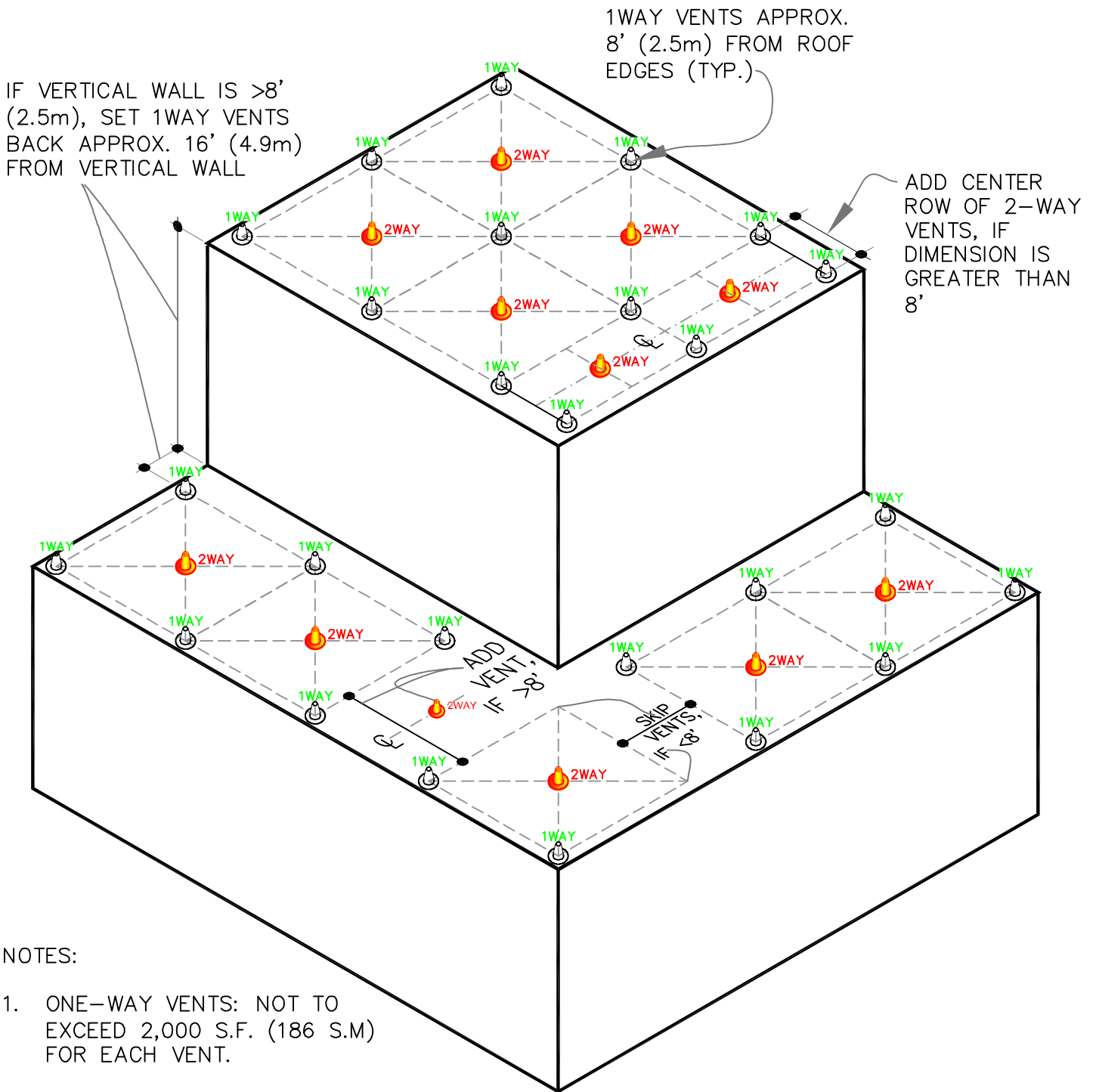

NOTES:

1. ONE-WAY VENTS: NOT TO EXCEED 2,000 S.F. (186 S.M) FOR EACH VENT.
2. TWO-WAY VENTS: NOT TO EXCEED 8,000 S.F. (743 S.M.) FOR EACH VENT
3. COORDINATE WITH VERSICO FOR IRREGULAR ROOF SHAPES OR WHERE DECK SLOPE EXCEEDS 2":12". SUBMIT CAD ROOF PLAN.

GRID TYP.
89.5'X89.5'=
~8,010 SF

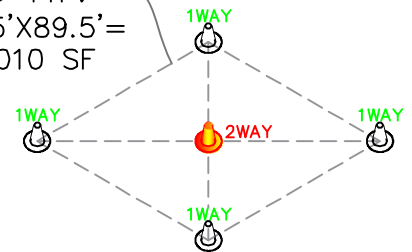

3D ROOF PLAN – TYPICAL LAYOUT OF VENTS

— ROOF MEMBRANE

0 — SEE NOTE(S)

DeckVent

DV-8

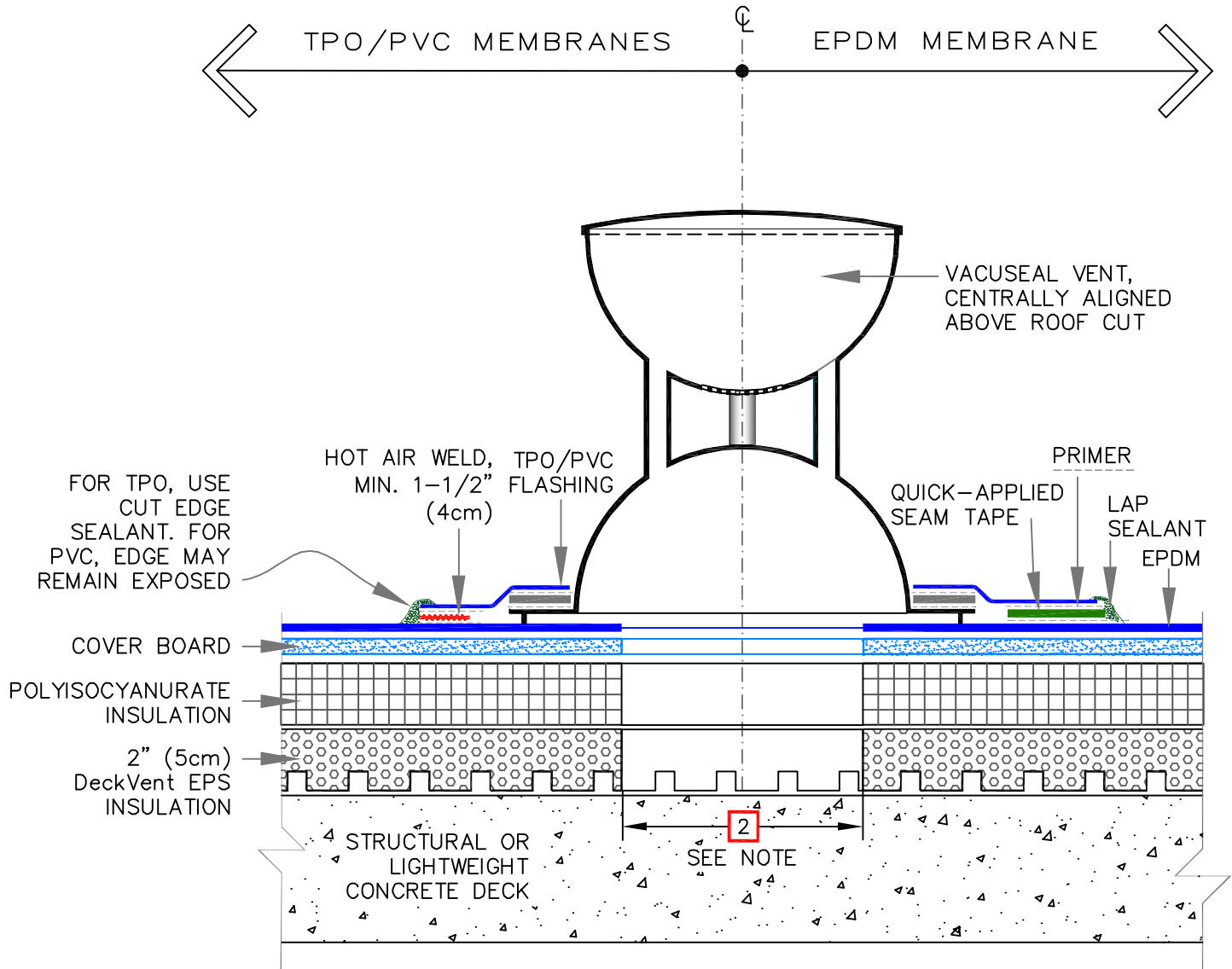

NOTES:

1. SUBMIT A COPY OF ROOF PLAN IN CAD TO VERSICO TO LOCATE VENTS SHOWING ALL PENETRATIONS, HVAC UNITS, HEIGHT OF PARAPET WALLS AND HEIGHT OF ROOF FROM GROUND. EACH VENT WILL COVER APPROXIMATELY 1,200 SQ. FEET (112 SQ. METERS).
2. CORE A 7" (18cm) DIAMETER OR (7"X7"(18x18cm)) HOLE THROUGH THE ROOF ASSEMBLY DOWN TO CONCRETE DECK. EXPOSE THE CONCRETE DECK SURFACE. REMOVE ALL LOOSE DEBRIS COMPLETELY. VACUUM ALL PARTICLES TO ENSURE THAT VENT TUBES & SCREEN WILL NOT BE CLOGGED.
3. THE ROOF ASSEMBLY SHALL BE AIR TIGHT. CONCRETE DECK MUST BE SEALED AROUND ALL PENETRATIONS AND AT ALL DECK TO WALLS/CURBS JUNCTIONS.



PRIMARY VENT (VACUSEAL VENT – CONCRETE LEVEL)	<table style="width: 100%; border-collapse: collapse;"> <tr> <td style="width: 20px; border-bottom: 2px solid blue;"></td> <td>→ ROOF MEMBRANE</td> </tr> <tr> <td style="width: 20px; border: 1px solid red; text-align: center;">0</td> <td>→ SEE NOTE(S)</td> </tr> </table>		→ ROOF MEMBRANE	0	→ SEE NOTE(S)
	→ ROOF MEMBRANE				
0	→ SEE NOTE(S)				

DeckVent
DV-9

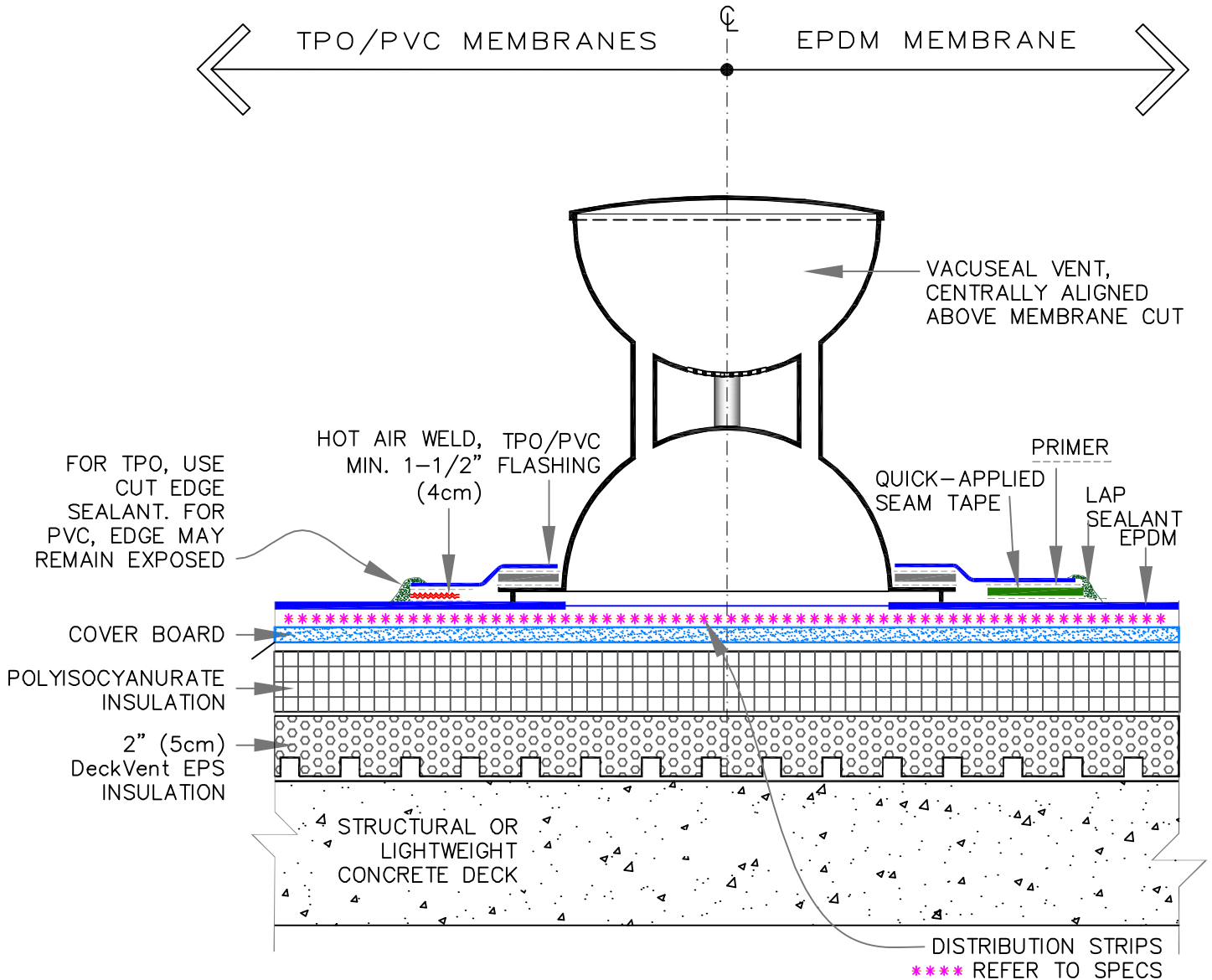

NOTE:

1. TOTAL NUMBER OF VENTS AND LOCATIONS ON THE ROOF WILL BE DETERMINED BY VERSICO. SUBMIT A COPY OF ROOF PLAN IN CAD TO VERSICO TO LOCATE VENTS. DESIGNER MUST SHOW ALL PENETRATIONS, HVAC UNITS, HEIGHT OF PARAPET WALLS AND HEIGHT OF ROOF FROM GROUND.



SECONDARY VENT (VACUSEAL VENT – MEMBRANE LEVEL)	<table style="width: 100%; border-collapse: collapse;"> <tr> <td style="width: 20px; border-bottom: 2px solid blue;"></td> <td>→ ROOF MEMBRANE</td> </tr> <tr> <td style="text-align: center; border: 1px solid red; width: 20px; height: 20px; margin: 5px 0;">0</td> <td>→ SEE NOTE(S)</td> </tr> </table>		→ ROOF MEMBRANE	0	→ SEE NOTE(S)
	→ ROOF MEMBRANE				
0	→ SEE NOTE(S)				

DeckVent
DV-10



SPECIFICATION

SUPPLEMENT

G-15-22

Flexible DASH Adhesive Equipment and Set-Up Requirements for Full Spray, Bead and Splatter Applications

January 2024

The information contained in this supplement serves as a criteria for Specifiers and Authorized Applicators regarding the design and installation of Versico Roofing Systems and related products. Additional information essential for the design and installation of the Roof Systems mentioned herein are also included in the respective Specification for each Roof System and in the Design Reference Section of the Versico Technical Manual. Specifiers and Authorized Applicators are advised to reference all applicable sections.

A. Equipment for Flexible DASH

The following is a list of necessary equipment for application of Flexible DASH Adhesive.

1. **Proportioning Unit (Pump)** - a mechanically operated, high or low pressure metering unit capable of providing 1000 to 2000 psi operating pressure for full spray or 300-500 psi operation for bead application and designed to accurately dispense two component chemical foam systems.
2. **Hoses** (for carrying Part-A and B materials from Proportioning Unit to dispensing unit) – either non-heated or heated hose assemblies available in lengths of 50’.
3. **Dispensing Method** (for applying Flexible DASH Adhesive) - a low or high-pressure dispensing gun for the application of two- component polyurethane foams.
4. **Air Compressor** – If applicable for dispensing equipment, consult equipment vendor for individual recommendations.
5. **Generator** – If applicable, consult equipment vendor for individual recommendations.

Conventional two-component pumping systems manufactured by Graco, 4C’s Spray Equipment, Amped Equipment and ARI are readily available new and used. Contact the respective manufacturer for additional information.

B. Equipment Settings by Application Method

1. Full Spray Application Equipment Settings

- a. Flexible DASH Adhesive is to be dispensed at a minimum dynamic pressure of 900 psi.
- b. Dispensing gun should be a Fusion Air Purge gun by Graco, or equivalent, with a splatter tip.

2. Bead Application Equipment Settings

- a. Follow manufacturer’s instructions for setting up spray rig for dispensing beads.

3. Splatter Application Equipment Settings

- a. Flexible DASH Adhesive should be dispensed in large droplets, not a fine mist. Air pressure/flow is too high if the Flexible DASH adhesive is dispensing in a fine mist.
- b. Patriot Spray Rig Settings
 - 1) Follow equipment vendor setup for the first-time use.
 - 2) Ensure Patriot has an air compressor and VEE-AIR Manifold installed.
 - 3) Air compressor: 80 psi.
 - 4) Patriot Setting: 6
 - 5) VEE-AIR gun: Air Valve to 0.5, Fluid 100% open
 - 6) Recommended Air Setting for material temperatures of 70-80°F. When material is warmer, air pressure may need to be reduced to ensure proper flow.
- c. HULK Spray Rig Settings
 - 1) Follow equipment vendor setup for the first-time use.
 - 2) Machine pressure: 60 psi.
 - 3) Gun Pressure: 80 psi.
 - 4) HULK gun: Air Valve to 100% open, Fluid 100% open.
 - 5) Recommended Air Setting for material temperatures of 70-80°F. When material is warmer, air pressure may need to be reduced to ensure proper flow.
- d. Dual Tank Settings
 - 1) Follow setup on Flexible DASH Dual Tank Product Data Sheet.
 - 2) The 14" extension nozzle should not be used for splatter application.

C. Installation Considerations

1. **Bead Adhesive Spacing** – Beads must be applied following spacing approved for specific project conditions (i.e. height, wind zone, and warranty wind speed coverage).

- a. While 12-inch on-center bead spacing is commonly used in the field of the roof, projects with higher wind speed coverage most likely require narrower spacing between beads.



- b. Perimeter bead spacing is typically at 6-inches on-center except for those projects with higher wind speed coverage where narrower bead spacing of 4-inches on-center may be required.

- c. Refer to [Detail A-27.7](#) in [Spec Supplement G-08-20 "Insulation Attachment and Details"](#) and [Detail VF-27](#) in VersiFleece Specification for Membrane Attachment using Bead Adhesive or contact Versico prior to installation.

d. Substrate irregularity, which is commonly associated with gravel surfaced built-up roofing, must be compensated to ensure insulation boards are fully embedded. Do not apply thin beads of adhesive (less than 1/2 inch wide, wet bead for Non-Dual Tank Applications and 1.5" wide, wet bead for Dual Tank Applications), and if necessary increase width of the adhesive bead in uneven areas.



2. Residual Asphalt

a. **Incompatibility of the Substrate (Residual Un-Weathered Asphalt)** – While urethane adhesive is compatible with existing asphaltic roofs that have been exposed and weathered, it is difficult to adhere to **slick, smooth and un-weathered asphalt**. This condition may be encountered when an existing roof is removed, exposing an asphaltic vapor barrier or leaving asphalt residue.

b. To ensure proper adhesive attachment, one of the following options may be followed:

- 1) Prime the surface with Versico's CAV-GRIP 3V, CCW-702, CCW-702LV or CCW-702WB Primer for splatter and bead application.
- 2) Switch to full spray of Flexible DASH Adhesive applied from heated spraying rig to increase surface contact. 100% full coverage is required. Splatter applications are not accepted.
- 3) Install Versico's VapAir Seal 725TR Air & Vapor Barrier with CAV-GRIP 3V, CCW-702, CCW-702LV or CCW-702WB Primer over the existing asphalt.
- 4) Use mechanical securement to attach the first layer of insulation in lieu of adhesive.

3. Air Infiltration

- a. On structural concrete decks, gaps between the structural deck and walls and those around penetrations, allows hot humid air from within the building to infiltrate the roofing assembly and possibly condense during cold season. Lower membrane temperature, especially those associated with white membranes, increase the probability of condensation and promote freezing during low temperatures. Collected frozen moisture trapped above the structural deck when thawed, will eventually lead to weakening of the bottom insulation facer. Weakening of the bottom of the insulation facer subsequently separation of the foam during wind event.

It is important to seal gaps around the perimeter and around penetrations, refer to [Spec Supplement G-01-21 "Construction Generated Moisture"](#), to eliminate moisture infiltration.

- b. The same phenomenon with migrating moisture could occur on steel decks, where gaps are not sealed or vapor retarders are not used. In such a case, condensed moisture could result in insulation gapping, rusting of metal fasteners or steel decks and cause insulation to become wet. Refer to [Spec Supplement G-01-21 "Construction Generated Moisture"](#).

Copyright 2024 Versico

Versico, VersiGard, VersiFleece, Flexible DASH Adhesive are Trademarks of Versico

This Spec Supplement represents the applicable information available at the time of its publication. Owners, Specifiers and Versico authorized roofing applicators should consult Versico or their Versico Independent Sales Representative for any information that has subsequently been made available.

Review the appropriate Versico Warranty for specific warranty coverage, terms, conditions and limitations.



SPECIFICATION

SUPPLEMENT

G-16-22

Plaza Paver Systems Adhered, Mechanically Fastened or Induction Welding Attachment Method

January 2024

The information contained in this supplement serves as criteria for Specifiers and Authorized Contractors regarding the design and installation of Versico Roofing Systems and related products. Additional information essential for the design and installation of the Roof Systems mentioned herein are also included in the respective Specification for each Roof System and in the Design Reference Section of the Versico Technical Manual. Specifiers and Authorized Contractors are advised to reference all applicable sections.

A. Description

The roofing assembly incorporates Versico supplied Concrete, Porcelain or Rubber Pavers in conjunction with a Versico Roofing membrane (EPDM, TPO, PVC, KEE HP) system installed in accordance with the appropriate Versico Roof Membrane Specification.

1. Membrane Roof Systems

The concrete and porcelain pavers are installed over a slip sheet of HP Protective Mat or 300 HV Protection Fabric in conjunction with an approved Paver Pedestal System over the roof membrane (EPDM, TPO, PVC or KEE HP). The Rubber Pavers are installed directly over the roof membrane (EPDM) or over a slip sheet of 300HV Protection Fabric (TPO, PVC or KEE HP).

- a. **Adhered Assemblies** – Using EPDM, TPO, PVC or KEE HP, insulation may be installed either mechanically (fastened directly to the deck) or set in Flexible DASH bead adhesive to the structural deck. Subsequent layers of insulation or coverboard may be mechanically fastened through all layers or set in Flexible DASH bead adhesive. The membrane shall be fully adhered using the appropriate bonding adhesive following Versico's Thermoset (EPDM), Thermoplastic (TPO, PVC, and KEE HP), VersiFleece (EPDM, TPO, PVC or KEE HP) or VersiFleece AFX (EPDM or TPO) membrane Specifications.
- b. **Induction Welded Assemblies** – Using TPO or PVC, insulation is mechanically fastened using appropriate Versico Fasteners and TPO or PVC Induction Welding Plates which are used to secure both layers to the structural deck. The fastening density of the plates and fasteners shall be in compliance with the Induction Welding Attachment (Attachment I) of the Thermoplastic Specification.
- c. **Mechanically Fastened Assemblies** – Using EPDM, TPO, PVC or KEE HP, membranes are mechanically fastened over insulation/underlayment to the deck with the appropriate Versico Fasteners and Fastening Plates. The fastening density of the plates and fasteners shall be installed per Versico's Thermoset (EPDM), Thermoplastic (TPO, PVC, and KEE HP) membrane Specification.

2. Inverted Roof Membrane Assembly (IRMA) Systems

A layer of drainage board/mat is loose-laid over the membrane. Layers of insulation are also loose-laid directly on the drainage board/mat. The concrete and porcelain pavers are installed over a slip sheet of HP Protective Mat or 300HV Protection Fabric in conjunction with an approved Paver Pedestal System over the insulation. The rubber pavers are installed over a slip sheet of HP Protective Mat over the insulation. NOTE: Porcelain and Rubber Pavers are lightweight, weighing 9 lb/sf and 6 lb/sf respectively. Check current building code requirements for building height, parapet height and project location to ensure that these overburden options are suitable in IRMA Assemblies.

- a. **Adhered Assemblies** – Using EPDM, TPO, PVC or KEE HP, the membrane is applied to the structural deck with an appropriate bonding adhesive.
- b. **Induction Welded Assemblies** – Using TPO or PVC, insulation is mechanically fastened using appropriate Versico Fasteners and TPO or PVC Induction Welding Plates are used to secure both layers to the structural deck. The

fastening density of the plates and fasteners shall be in compliance with the Induction Welding Attachment (Attachment I) of the Thermoplastic Specification.

- c. **Mechanically Fastened Assemblies** – Using EPDM, TPO, PVC or KEE HP, the membrane is installed mechanically fastened directly to the structural deck.

Any of the assemblies described herein, using a minimum 60-mil membrane, are eligible for a 5, 10, 15, or 20 Year Membrane System Warranty with a Warranty wind speed up to 72 mph. For higher wind speed coverage, project may be submitted to Versico for Approval. An Overburden Removal and Replacement Warranty is available with all Versico supplied Plaza Paver Systems (Concrete, Porcelain and Rubber) with 10, 15, or 20 Year Durations for an additional fee.

B. Quality Assurance

1. The specified roofing system must be installed by a Versico Authorized Roofing Contractor in compliance with drawings and specifications as approved by Versico.
2. Roof system must be inspected and approved by a Technical Representative of Versico prior to Plaza Paver System installation.
3. Do not install this assembly before the concrete deck has reached its' initial structural strength. Project Engineer must be consulted prior to job start-up.

C. Submittals

1. Shop drawings must be submitted to Versico by the Versico Authorized Roofing Contractor along with a completely executed Copy-A Job Approval Request for approval. Approved shop drawings are required for inspection of the roof and on projects where on-site technical assistance is requested.
2. Upon completion of the installed work, submit copies of the manufacturer's final inspection to the specifier prior to the issuance of the manufacturer's warranty.

D. Products

In addition to the products listed below, products listed in "Part II" of the Versico Thermoset/Thermoplastic Roofing System Specification can be used as part of the Plaza Paver System.

1. Hanover® Pavers

- a. **Prest Pavers:** Hanover Roof and Plaza Pavers provide durability, protection and performance for the roof system from harsh weather conditions. A textured Tudor® finish provides slip resistant properties making Hanover Pavers safer than gravel ballast for pedestrians. By elevating the pavers, water is channeled away from the surface. Roof Pavers allow easy access to the roof and waterproofing system for repairs or standard maintenance procedures. Available in Tudor Finish, 8 standard colors (custom available), in a standard size of 23.5" x 23.5" x 2" (other sizes available upon request) and weighs 25 lb/sf. The use of Hanover Pavers requires the use of one of the pedestals below to maintain material warranty.
 1. **High Tab Pedestals** – are 5/8" high and are stackable to increase the height.
 2. **EPDM Pedestal and Leveling Shims** – are 3/8" fixed height but are not stackable.
 3. **Elevator Pedestal** – consisting of a base and top plate which can be combined with various size couplers to increase height.
- b. **Pedestal Pavers:** For use as an alternative to standard concrete pavers and polyethylene or EPDM pedestal systems, Hanover Pedestal Pavers are produced with integrated concrete feet providing a 1/2" elevation clearance for water drainage. Available in Tudor Finish (for aesthetics) or Diamond (for walkways), 8 standard colors (custom available), in a standard size of 23.5" x 23.5" x 2.25" and weighs 22 lb/sf. As the paver is produced with integral, pedestal feet, additional pedestal systems are not recommended or required. The use of 300HV Protection Fabric is required with this paver.
- c. **Guardian Pavers:** The Hanover Guardian® Paver System is specially designed to create a monolithic paver surface which provides high wind uplift resistance. Guardian is made up of a unique 3-piece Guardian Pedestal and a specially shaped Guardian Paver that, together, "lock down" and unitize the entire roof paver surface, preventing horizontal and vertical movement. The Guardian Pedestal has a square top that allows its bolt to pass through to a base beneath, fitting into a recessed grooved portion of the Guardian Paver. Available in multiple finishes, 10 standard colors (custom available), in standard sizes of 17.625" x 35.375" x 2" or 3", 23.5" x 23.5" x 2" or 3", 23.5" x

35.375" x 2" or 3", OR 29.75" x 29.75" x 2" and weighs 25 lb/sf for 2" thicknesses and 38 lb/sf for 3" thicknesses. Guardian pavers must be used with specialized pedestals consisting of a standard elevator pedestal base combined with a patented locking top cap (available in 8 colors). The system achieved -81.1 psf uplift resistance according to Florida's TAS (Testing Application Standard) 108 test.

- d. **Porcelain Pavers:** Hanover® Porcelain Pavers are a premium alternative to concrete pavers. They are hard-wearing, anti-slip, weather resistant and capable of withstanding heavy loads without comprising aesthetics. Porcelain Pavers are resistant to acid, chemicals, mold and salt. They will not stain and do not require sealing. Porcelain Pavers are installed over standard Hanover elevator pedestal bases combined with Hanover's low-tab pedestal tops specially designed for the porcelain pavers, providing an 1/8" joint for water drainage. Porcelain Pavers only weigh approximately 9 pounds per square foot and do not satisfy typical ballast uplift requirements. To increase wind uplift performance, combine with Hanover's ballasted GridLoc structural support system. Available in multiple finishes, 17 colors/designs, in standard sizes of 12" x 48" x 2" or 3/4", 16" x 32" x 3/4", 16" x 48" x 3/4", 24" x 24" x 3/4" OR 24" x 48" x 3/4" and weighs approximately 9 lb/sf.

2. Sunny Brook Pavers

- a. **Pressed Concrete Pavers:** Sunny Brook pressed concrete pavers are available in a wide variety of sizes, colors, patterns and textures to accent any building, decor and landscaping. The standard Quarry Stone texture combines aesthetic appeal of decorative aggregates with the strength of concrete to create pavers that are strong, durable and beautiful. Available in Quarry Stone Texture (standard, with 5 additional finishes available), 21 standard colors, in a standard size of 23.5" x 23.5" x 2" (additional sizes available upon request) and weighs 24 lb/sf. Sunny Brook Pavers use MRP Support pedestals as supplied by Versico.

3. Westile Pavers

- a. **Western Plaza Pavers:** Westile Western Plaza Pavers are made of a high-density concrete and are well-suited for use in plaza decks, providing a durable, elegant surface while protecting the roof membrane and increasing amenity space. Westile Western Plaza Pavers are to be used in conjunction with high-density polypropylene pedestals that facilitate proper spacing and drainage and provide the ability to create a dead level surface. Available exclusively for projects in the western United States and Canada including the following states and provinces: Alaska, Arizona, California, Colorado, Hawaii, Idaho, Montana, Nevada, New Mexico, Oregon, Utah, Washington, Wyoming, British Columbia, Alberta, Saskatchewan. Available in Shot Blast Texture (standard, with matte finish available as a special order), 7 standard colors, in a standard size of 24" x 24" x 1.8125" (additional sizes available upon request) and weighs 23 lb/sf. Westile Western Plaza Pavers use Bison or MRP Support pedestals as supplied by Versico.

4. Versico Rubber Pavers

- a. **Plus Series Rubber Pavers:** Made of recycled rubber, the Plus Series pavers are an economical solution intended for use in low traffic areas as well as walkways to rooftop mechanical units. Available in 6 standard colors, in a standard size of 24" x 24" x 2" and weighs 6 lb/sf. Special adhesive must be applied to all paver-to-paver joints using a special adhesive application tip, once all pavers are in place. Adhesive helps keep pavers from separating during expansion and contraction due to temperature fluctuations. Pavers are installed directly over EPDM roofing membranes or over 300HV Protection Fabric for TPO, PVC and KEE HP roofing membranes.
 - b. **Premium Rubber Pavers:** Premium Series Rubber Pavers feature a top wearing surface of SBR recycled rubber as well as varying percentages of EPDM virgin rubber for superior durability, as well as, wear and fade resistance. This makes the Premium Series pavers ideal for high traffic and plaza areas, and a great alternative to concrete paver systems. The Premium Series also features a broader range of color options that can aide in artistic rooftop design. Available in 10 standard colors, in a standard size of 24" x 24" x 2" and weighs 6 lb/sf. Special adhesive must be applied to all paver-to-paver joints using a special adhesive application tip, once all pavers are in place. Adhesive helps keep pavers from separating during expansion and contraction due to temperature fluctuations. Pavers are installed directly over EPDM roofing membranes or over 300HV Protection Fabric for TPO, PVC and KEE HP roofing membranes.
5. **HP Protection Mat:** a nominal 6 oz. per square yard, UV-resistant, polypropylene, needle-punched fabric. HP Protective Mat is installed as a slip sheet for some paver applications.
 6. **300HV Protection Fabric:** a (16 oz/ sq yd) extremely tough non-woven polypropylene fabric designed for use as a protection course over Versico's roofing membranes providing cushion for heavy overburden materials. 300HV Protection Fabric is non-biodegradable and stabilized to resist soil, chemicals and mildew, as well as acids and alkalis.

E. Execution

Follow current specifications for installing roof membranes and seaming per specific membrane. [VersiGard (EPDM), VersiWeld (TPO) or VersiFlex (PVC/KEE HP)].

General

Exercise care in placing pavers and pedestals over roofing or waterproofing so protection materials are not displaced and roofing or waterproofing is not punctured or otherwise damaged. Carefully replace protection materials that become displaced and arrange for repair of damaged roofing or waterproofing before covering with paver system.

F. Installation

1. Proceed with installing roofing system as described in this section and in accordance with Versico published Specifications for the specific membrane type.
2. After installation of the roofing membrane, install slip sheet of HP Mat or 300HV Protective Fabric, as required by paver system, as outlined above.
3. Install appropriate paver pedestal as outlined by the plaza paver system selected.
4. Install Plaza Paver according to manufacturer’s written instructions.

G. Associated Installation Details

Concrete Pavers on Pedestals.....	PD-A
Concrete Pavers on Low-Rise or Fixed Height Pedestals.....	PD-B
Concrete Pedestal Pavers	PD-C
IRMA Concrete Paver Assembly – Option 1	PD-D
IRMA Concrete Paver Assembly – Option 2	PD-E
Drain Detail – Low-Rise or Fixed Height Paver Assemblies.....	PD-6.1
Drain Detail –Adjustable Height Paver Pedestal Assembly.....	PD-6.2
Vertical Termination	PD-12.1
Vertical Termination – High-Wind Option	PD-12.2
Horizontal Termination – Aesthetic Option	PD-12.3
Horizontal Termination – High-Wind Option.....	PD-12.4
Rubber Interlocking Pavers.....	PD-RA
Rubber Paver Joint Adhesive Application	PD-R4.1
Drain Detail - Rubber Paver.....	PD-R6.1
Horizontal Termination – Aesthetic Option	PD-R12.3
Horizontal Termination – High-Wind Option.....	PD-R12.4

End of Section

Copyright 2024 Versico
Versico, ChannelDry, VersiGard, VersiWeld and VersiFlex are Trademarks of Versico

Hanover, Tudor Hanover Pedestal and Guardian are Trademarks of Hanover Architectural Products

This specification represents the applicable information available at the time of its publication. Owners, specifiers and Versico Authorized Roofing contractors should consult Versico or their Versico Independent Sales Representative for any information, which has subsequently been made available.



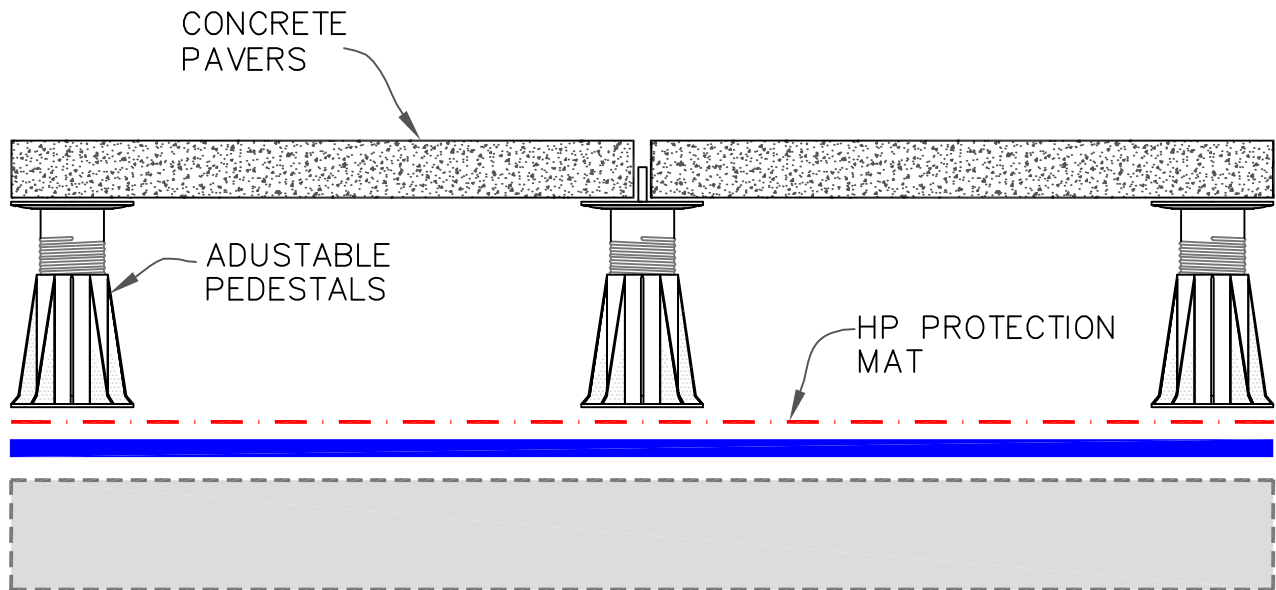

Review the appropriate Versico warranty for specific warranty coverage, terms, conditions and limitations.



NOTES:

1. APPROVED ROOF ASSEMBLY. REFER TO SPECIFICATIONS



-  EPDM/TPO/PVC
-  CONCRETE
- 0 SEE NOTE(S)
-  HP PROTECTIVE MAT
-  300HV PROTECTION FABRIC

CONCRETE PAVERS ON PEDESTALS	
2022 PAVER DETAILS	DETAIL NO. PDI A

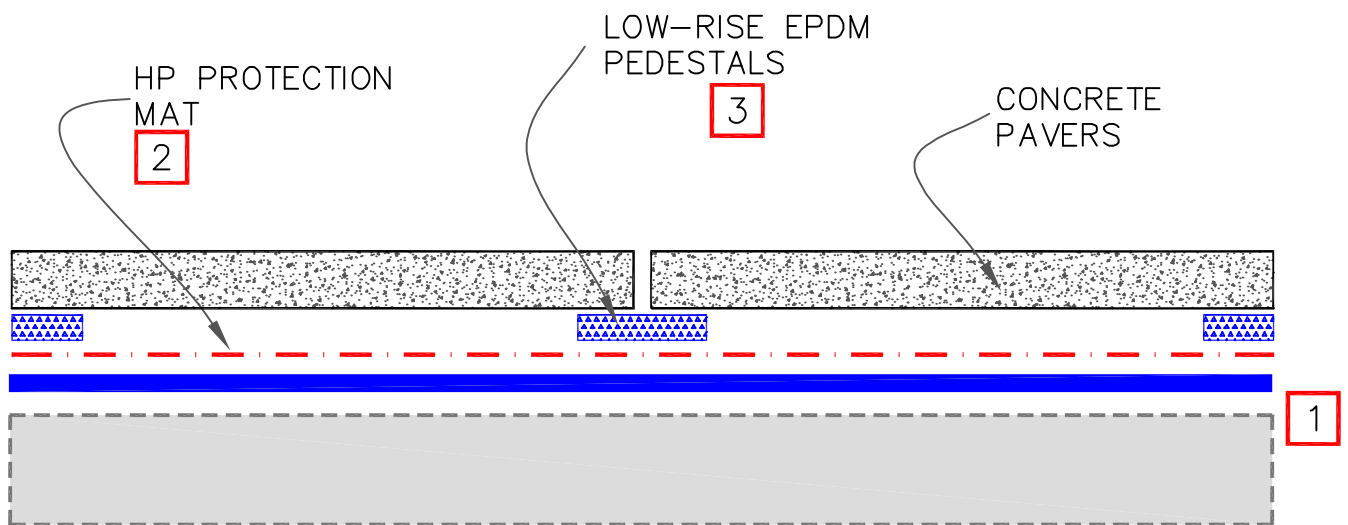

NOTES:

1. APPROVED ROOF ASSEMBLY. REFER TO SPECIFICATIONS
2. HP MAT IS NOT REQUIRED WHEN USING EPDM PEDESTALS OVER EPDM OR TPO MEMBRANES
3. AS AN ALTERNATIVE TO LOW-RISE EPDM PEDESTALS, FIXED-HEIGHT PLASTIC PEDESTALS, LEVELING SHIMS AND SLOPE COMPENSATORS CAN ALSO BE USED



- EPDM/TPO/PVC
- CONCRETE
- SEE NOTE(S)
- HP PROTECTIVE MAT
- 300HV PROTECTION FABRIC



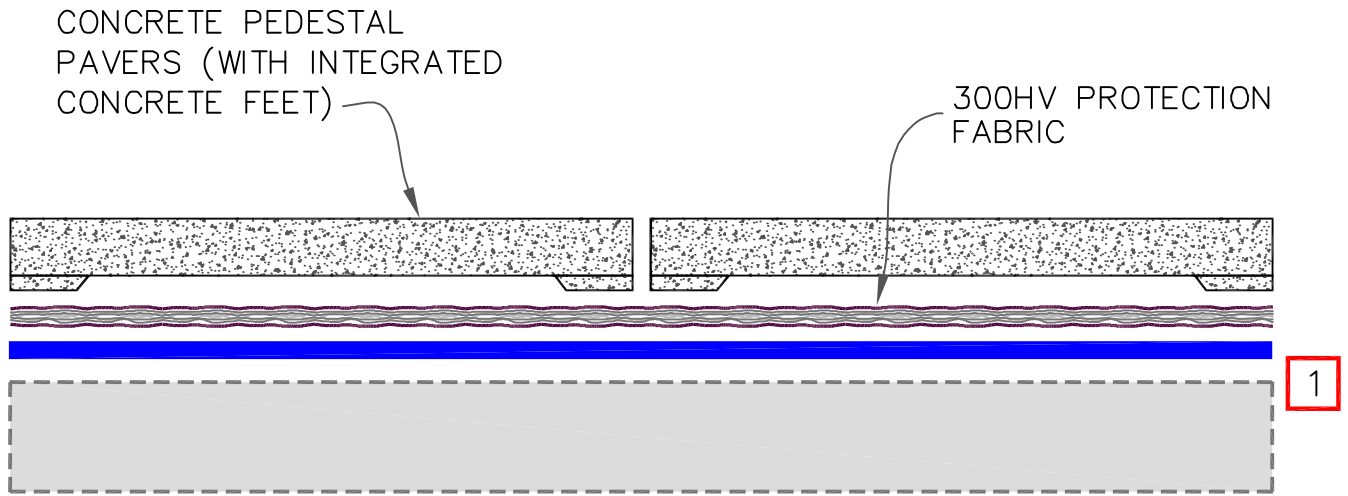

CONCRETE PAVERS ON LOW-RISE OR FIXED HEIGHT PEDESTALS	
2022 PAVER DETAILS	DETAIL NO. PDI B



NOTE:

1. APPROVED ROOF ASSEMBLY. REFER TO SPECIFICATIONS



-  EPDM/TPO/PVC
-  CONCRETE
-  SEE NOTE(S)
-  HP PROTECTIVE MAT
-  300HV PROTECTION FABRIC

CONCRETE PEDESTAL PAVERS	
2022 PAVER DETAILS	DETAIL NO. PDI C

POLYSTYRENE INSULATION	
COMPRESSIVE STRENGTH	DENSITY
25 POUNDS/INCH ²	2 POUNDS/FOOT ³
17,577 KILOGRAM/METER ²	32.1 KILOGRAM/METER ³

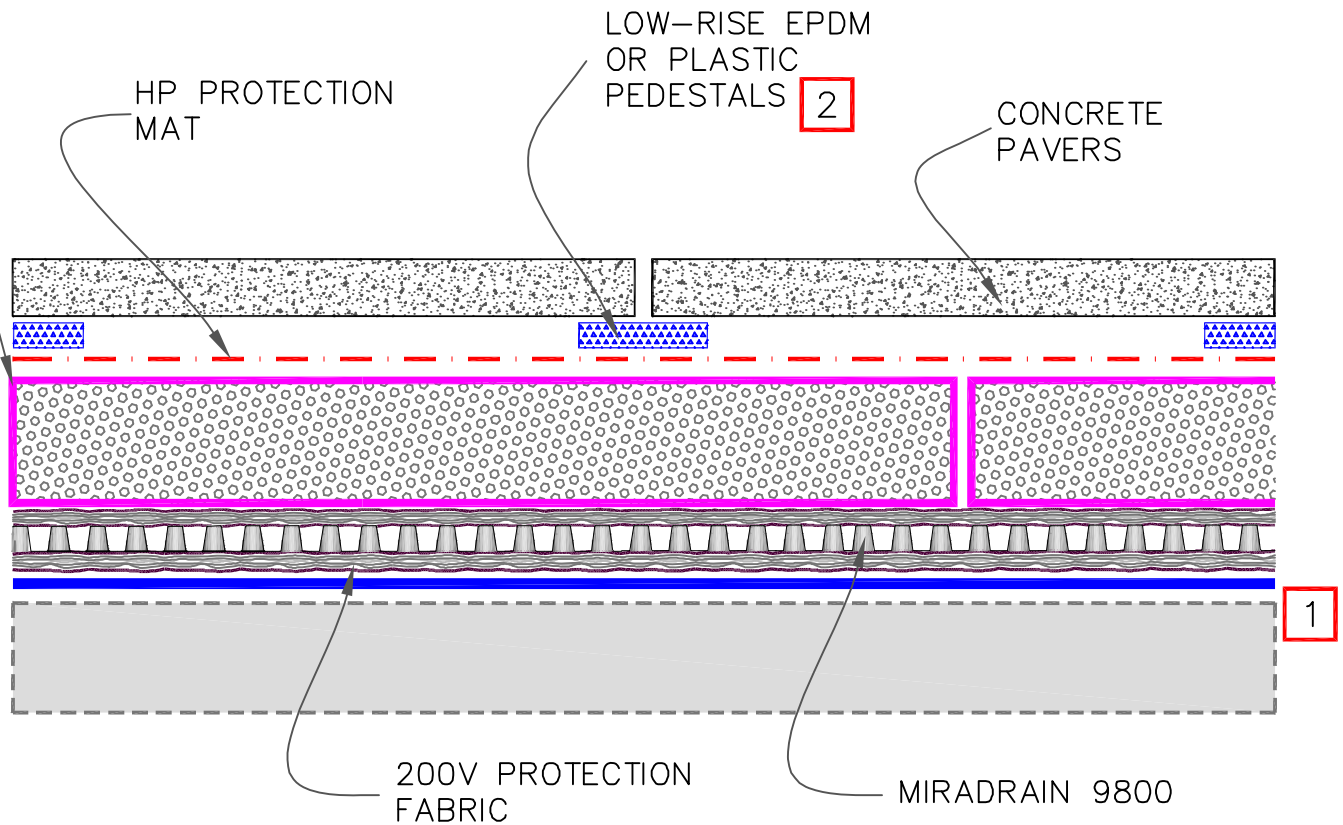

NOTES:

1. APPROVED ROOF ASSEMBLY. REFER TO SPECIFICATIONS.
2. ADJUSTABLE SCREW-JACK PEDESTALS OR PEDESTAL PAVERS MAY ALSO BE USED.



- EPDM/TPO/PVC
- CONCRETE
- SEE NOTE(S)
- HP PROTECTIVE MAT
- 300HV PROTECTION FABRIC



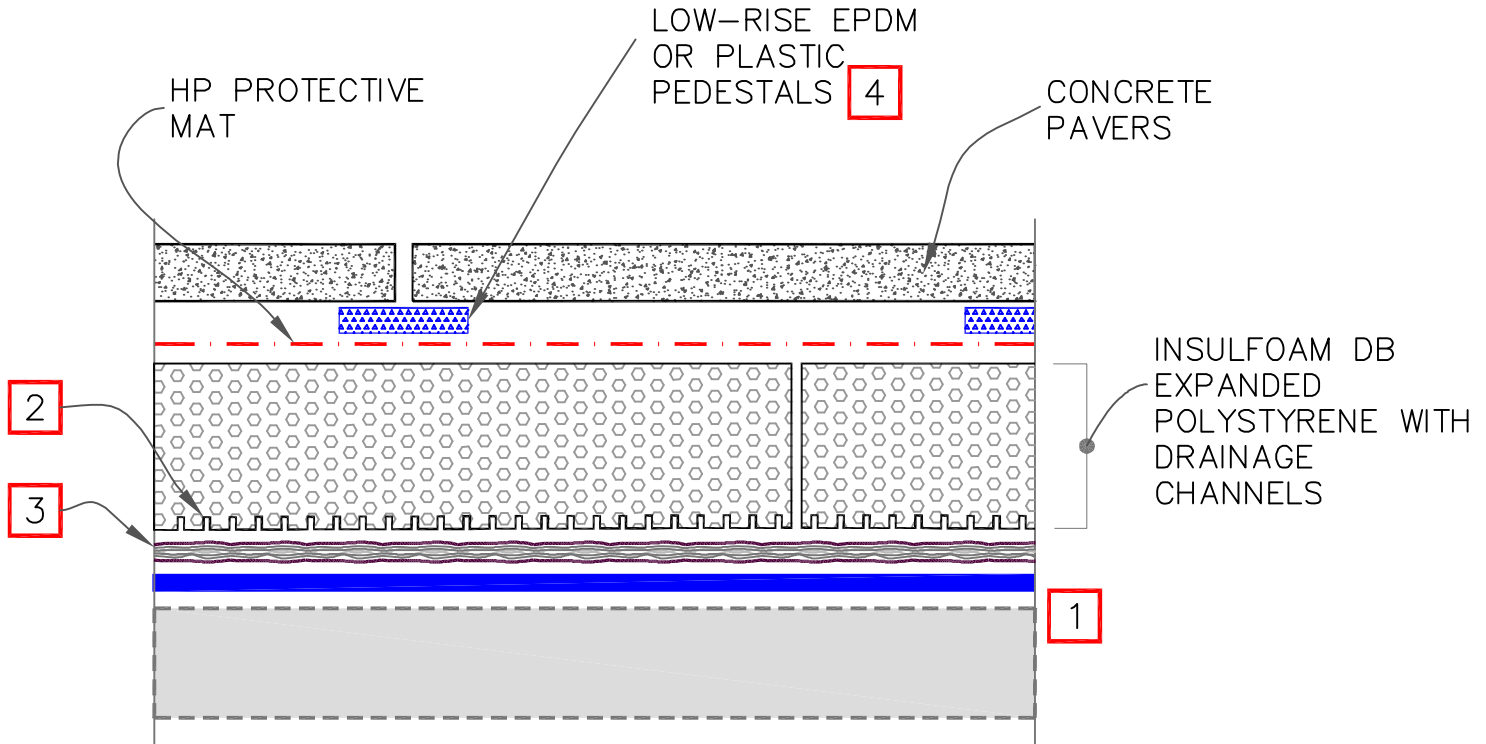

IRMA CONCRETE PAVER ASSEMBLY – OPTION 1	
2022 PAVER DETAILS	DETAIL NO. PDI D



NOTES:

1. APPROVED ROOF ASSEMBLY. REFER TO SPECIFICATIONS.
2. DRAINAGE CHANNELS TO BE ORIENTED IN THE DIRECTION OF ROOF DRAINS
3. IF POLYSTYRENE INSULATION IS USED IN CONJUNCTION WITH PVC MEMBRANE, 300HV PROTECTION FABRIC IS NEEDED BETWEEN EPS AND PVC.
4. ADJUSTABLE SCREW-JACK PEDESTALS OR PEDESTAL PAVERS MAY ALSO BE USED.



-  EPDM/TPO/PVC
-  CONCRETE
-  SEE NOTE(S)
-  HP PROTECTIVE MAT
-  300HV PROTECTION FABRIC



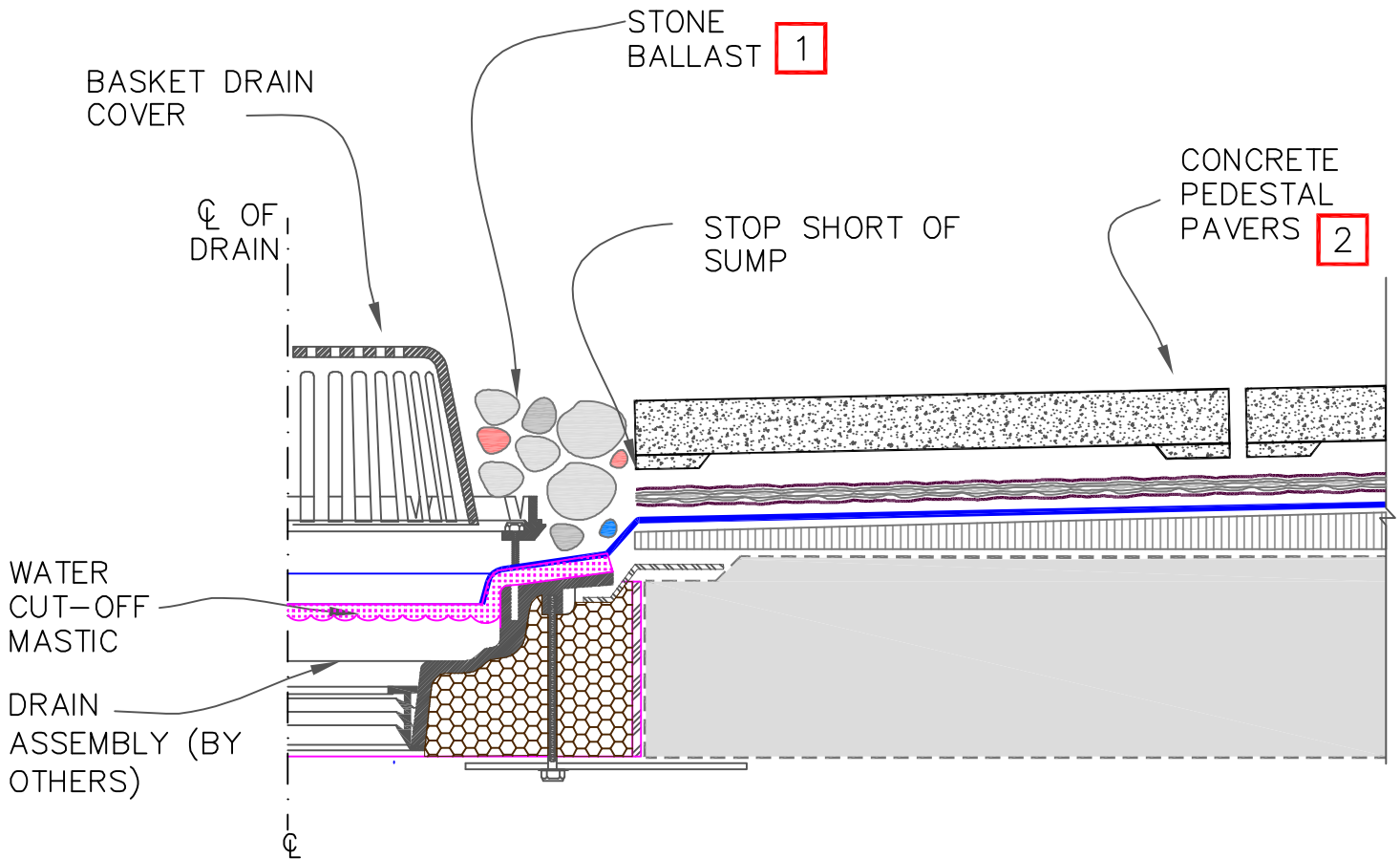

IRMA CONCRETE PAVER ASSEMBLY – OPTION 2	
2022 PAVER DETAILS	DETAIL NO. PDI E



NOTES:

1. STONE BALLAST IS OPTIONAL TO PROVIDE AESTHETICS.
2. AS AN ALTERNATE TO CONCRETE PEDESTAL PAVERS, STANDARD CONCRETE PAVERS ON FIXED HEIGHT PEDESTALS CAN ALSO BE USED. REFER TO DETAIL PD B FOR ASSEMBLY INFORMATION.



-  EPDM/TPO/PVC
-  CONCRETE
-  SEE NOTE(S)
-  HP PROTECTIVE MAT
-  300HV PROTECTION FABRIC



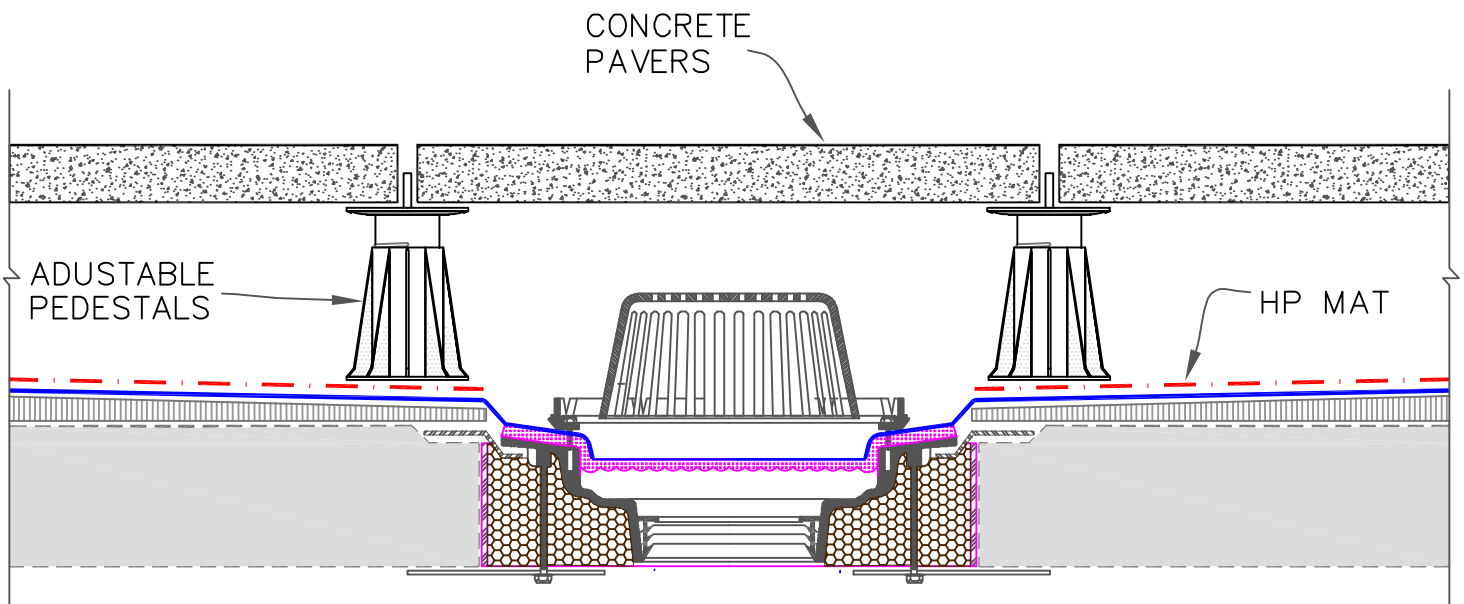

DRAIN DETAIL – LOW-RISE, FIXED HEIGHT PEDESTAL OR PEDESTAL PAVER ASSEMBLIES	
2022 PAVER DETAILS	DETAIL NO.
	PDI 6.1



NOTE:

1. THIS OPTION IS ONLY APPLICABLE TO PAVERS ON ADJUSTABLE PEDESTALS WHEN THERE IS ENOUGH HEIGHT ADJUSTMENT TO CLEAR DRAIN BASKETS



-  EPDM/TPO/PVC
-  CONCRETE
-  SEE NOTE(S)
-  HP PROTECTIVE MAT
-  300HV PROTECTION FABRIC

DRAIN DETAIL – ADJUSTABLE HEIGHT PAVER PEDESTAL ASSEMBLY	
2022 PAVER DETAILS	DETAIL NO. PDI 6.2



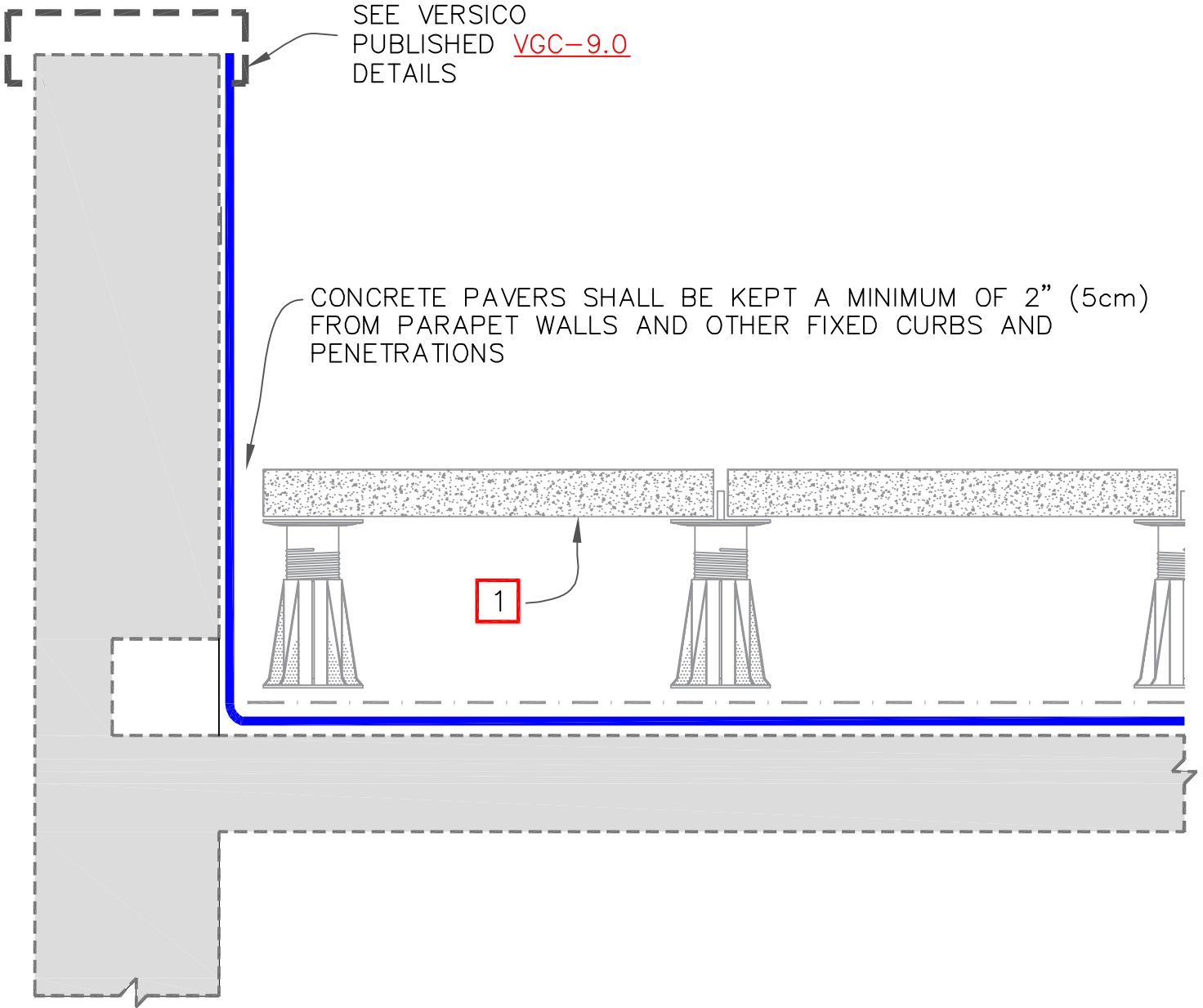

CAUTION

CONCRETE PAVERS MUST NOT BE USED AS WALKWAYS NEAR THE ROOF EDGES, PARAPET WALLS AND UNPROTECTED AREAS WITHOUT FALL PROTECTION.



NOTE:

1. CONCRETE PAVERS ON ADJUSTABLE PEDESTALS SHOWN. REFER TO PD DETAIL B, C, D, AND E FOR ACCEPTABLE ALTERNATIVE ASSEMBLIES.

 <p>VERSICO ROOFING SYSTEMS © 2023 VERSICO</p>	<ul style="list-style-type: none">  EPDM/TPO/PVC  CONCRETE 0 SEE NOTE(S)  HP PROTECTIVE MAT  300HV PROTECTION FABRIC 	ALL ASSEMBLIES	
		VERTICAL TERMINATION	
		2022 PAVER DETAILS	DETAIL NO. PDI 12.1

CAUTION



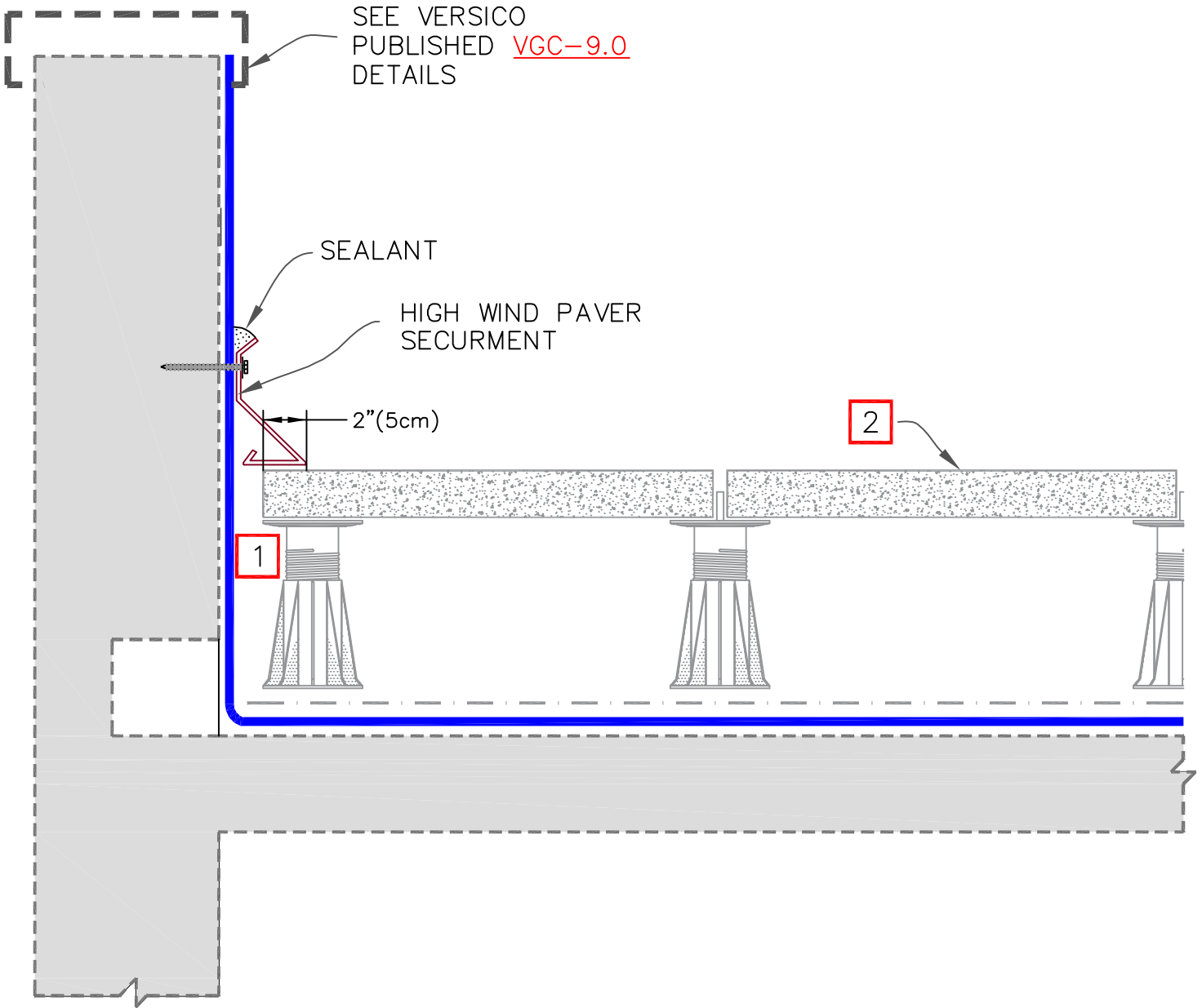

CONCRETE PAVERS MUST NOT BE USED AS WALKWAYS NEAR THE ROOF EDGES, PARAPET WALLS AND UNPROTECTED AREAS WITHOUT FALL PROTECTION.



NOTES:

1. PAVERS SHALL BE KEPT A MINIMUM OF 2" (5cm) FROM PARAPET WALL.
2. CONCRETE PAVERS ON ADJUSTABLE PEDESTALS SHOWN. REFER TO PD DETAIL B, C, D, AND E FOR ACCEPTABLE ALTERNATIVE ASSEMBLIES.



-  EPDM/TPO/PVC
-  CONCRETE
-  SEE NOTE(S)
-  HP PROTECTIVE MAT
-  300HV PROTECTION FABRIC

ALL ASSEMBLIES	
VERTICAL TERMINATION HIGH-WIND OPTION	
2022 PAVER DETAILS	DETAIL NO. PDI 12.2

***CAUTION**
 CONCRETE PAVERS AS A WALKWAY MUST BE LOCATED MIN. 6'-0" (183cm) AWAY FROM THE NEAREST UNPROTECTED ROOF EDGES OR AS REQUIRED PER APPLICABLE LOCAL CODES/OSHA REQUIREMENTS.

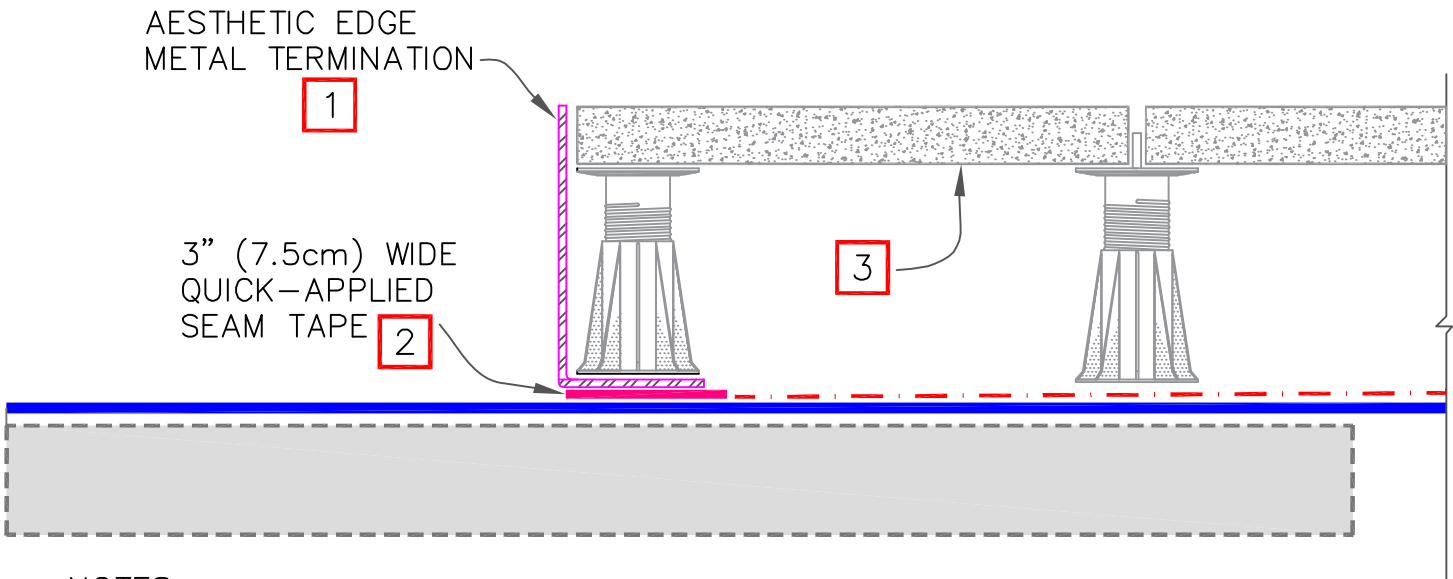

NOTES:

1. METAL EDGE TREATMENT IS USED FOR AESTHETICS AND NOT NEEDED FOR WARRANTY COMPLIANCE
2. QUICK-APPLIED SEAM TAPE SHALL EXTEND 1/4" (1cm) BEYOND EDGE OF METAL EDGE TO PROTECT ROOF MEMBRANE FROM METAL BURRS & CORNERS
3. CONCRETE PAVERS ON ADJUSTABLE PEDESTALS SHOWN. REFER TO PD DETAIL B, C, D, AND E FOR ACCEPTABLE ALTERNATIVE ASSEMBLIES.



- EPDM/TPO/PVC
- CONCRETE
- 0** → SEE NOTE(S)
- HP PROTECTIVE MAT
- 300HV PROTECTION FABRIC

ALL ASSEMBLIES	
HORIZONTAL TERMINATION AESTHETIC OPTION	
2022 PAVER DETAILS	DETAIL NO. PDI 12.3

***CAUTION**

CONCRETE PAVERS AS A WALKWAY MUST BE LOCATED MIN. 6'-0" (183cm) AWAY FROM THE NEAREST UNPROTECTED ROOF EDGES OR AS REQUIRED PER APPLICABLE LOCAL CODES/OSHA REQUIREMENTS.

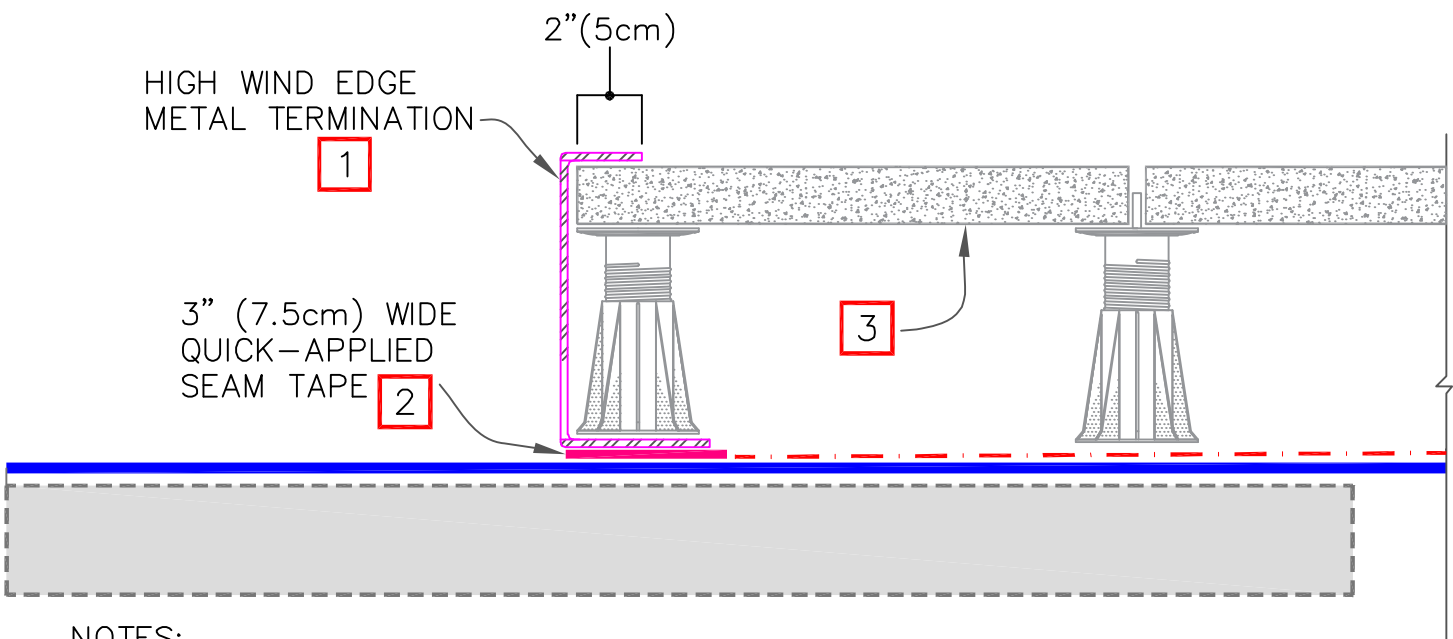

NOTES:

1. HIGH WIND METAL EDGE TREATMENT SHOULD BE USED IN HIGHER WIND APPLICATIONS TO HELP SECURE THE EXPOSED PERIMETER PAVERS. NOT REQUIRED FOR WARRANTY COMPLIANCE.
2. QUICK-APPLIED SEAM TAPE SHALL EXTEND 1/4" (1cm) BEYOND EDGE OF METAL EDGE TO PROTECT ROOF MEMBRANE FROM METAL BURRS & CORNERS
3. CONCRETE PAVERS ON ADJUSTABLE PEDESTALS SHOWN. REFER TO PD DETAIL B, C, D, AND E FOR ACCEPTABLE ALTERNATIVE ASSEMBLIES.



- EPDM/TPO/PVC
- CONCRETE
- SEE NOTE(S)
- HP PROTECTIVE MAT
- 300HV PROTECTION FABRIC

ALL ASSEMBLIES	
HORIZONTAL TERMINATION HIGH-WIND OPTION	
2022 PAVER DETAILS	DETAIL NO. PDI 12.4

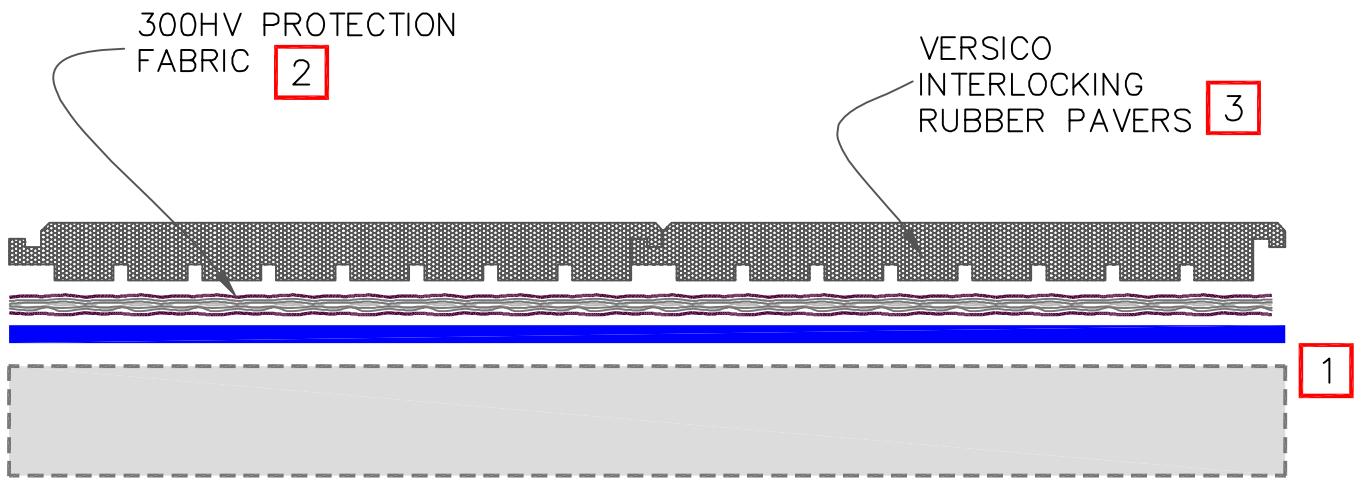

NOTES:

1. APPROVED ROOF ASSEMBLY. REFER TO SPECIFICATIONS
2. 300HV PROTECTION FABRIC IS NOT REQUIRED WHEN PLACING RUBBER PAVERS OVER EPDM MEMBRANE
3. RUBBER PAVERS MUST BE INSTALLED UNDER COMPRESSION. REFER TO VERSICO'S RUBBER PAVER INSTALLATION GUIDE FOR MORE INFORMATION.



- EPDM/TPO/PVC
- SEE NOTE(S)
- HP PROTECTIVE MAT
- 300HV PROTECTION FABRIC

RUBBER INTERLOCKING PAVERS	
2022 PAVER DETAILS	DETAIL NO. PDI RA

AFTER ALL PAVERS ARE INSTALLED, CARLISLE RUBBER PAVER ADHESIVE SHALL BE APPLIED IN ALL PAVER TO PAVER JOINTS USING VERSICO'S SPECIALIZED RUBBER PAVER ADHESIVE APPLICATION TIP

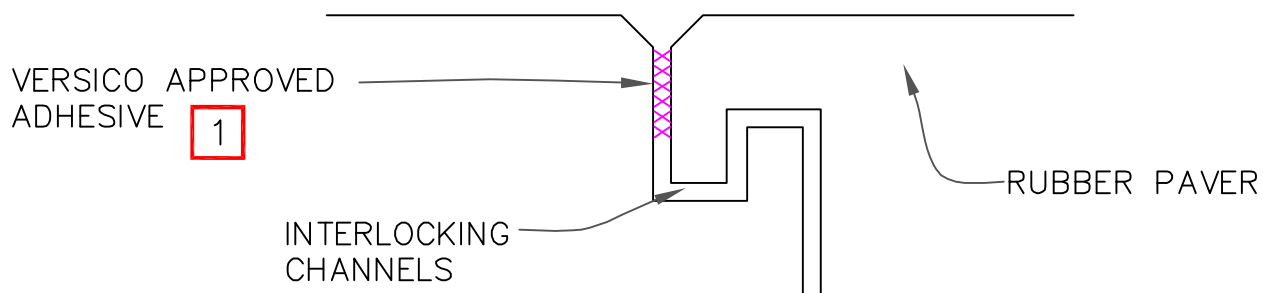

NOTES:

- ADHESIVE SHALL BE APPLIED BETWEEN THE VERTICAL WALLS OF THE INTERLOCKING JOINT AND NOT ON THE BOTTOM OF THE CHANNEL
- SEE VERSICO'S RUBBER PAVER INSTALLATION GUIDE FOR MORE INFORMATION

ADHESIVE APPLICATION TIP

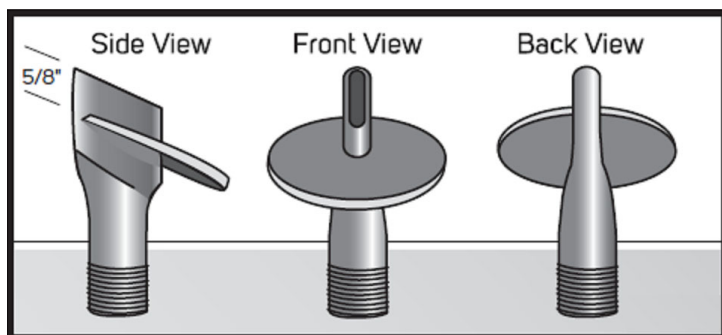

PROPER ADHESIVE APPLICATION

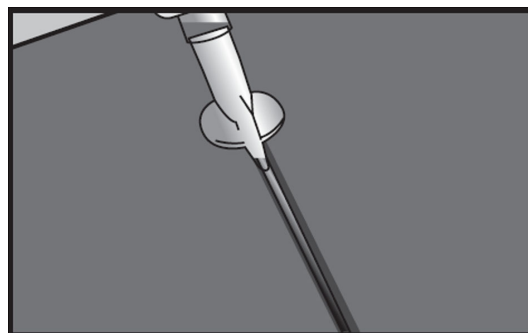

- EPDM/TPO/PVC
- 0** → SEE NOTE(S)
- HP PROTECTIVE MAT
- 300HV PROTECTION FABRIC

RUBBER PAVER JOINT ADHESIVE APPLICATION	
2022 PAVER DETAILS	DETAIL NO. PDI R4.1

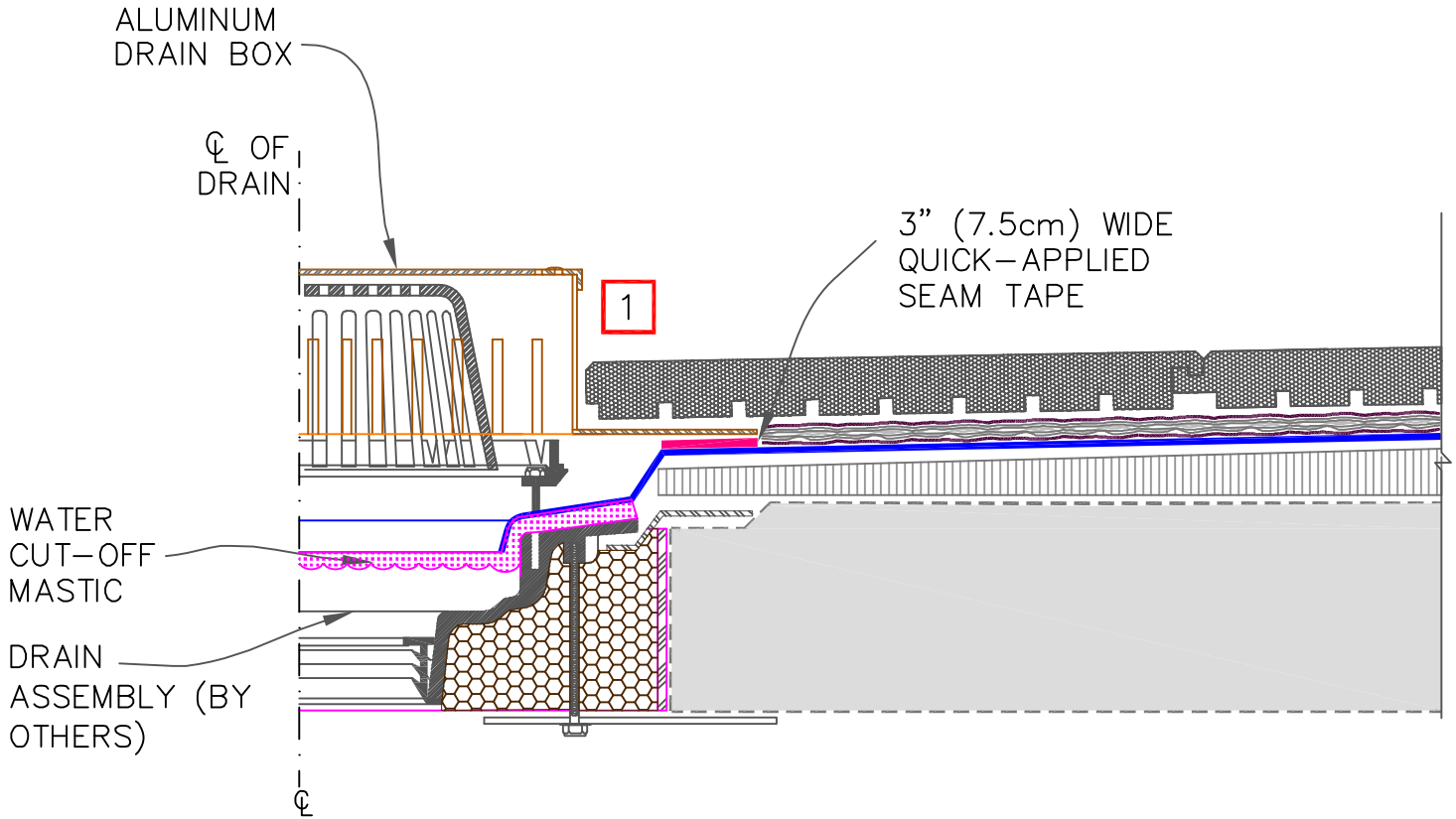

NOTE:

1. RUBBER PAVERS SHOULD BUTT TIGHTLY TO DRAIN BOXES TO MAINTAIN COMPRESSION.



- EPDM/TPO/PVC
- 0 → SEE NOTE(S)
- - - HP PROTECTIVE MAT
- 300HV PROTECTION FABRIC



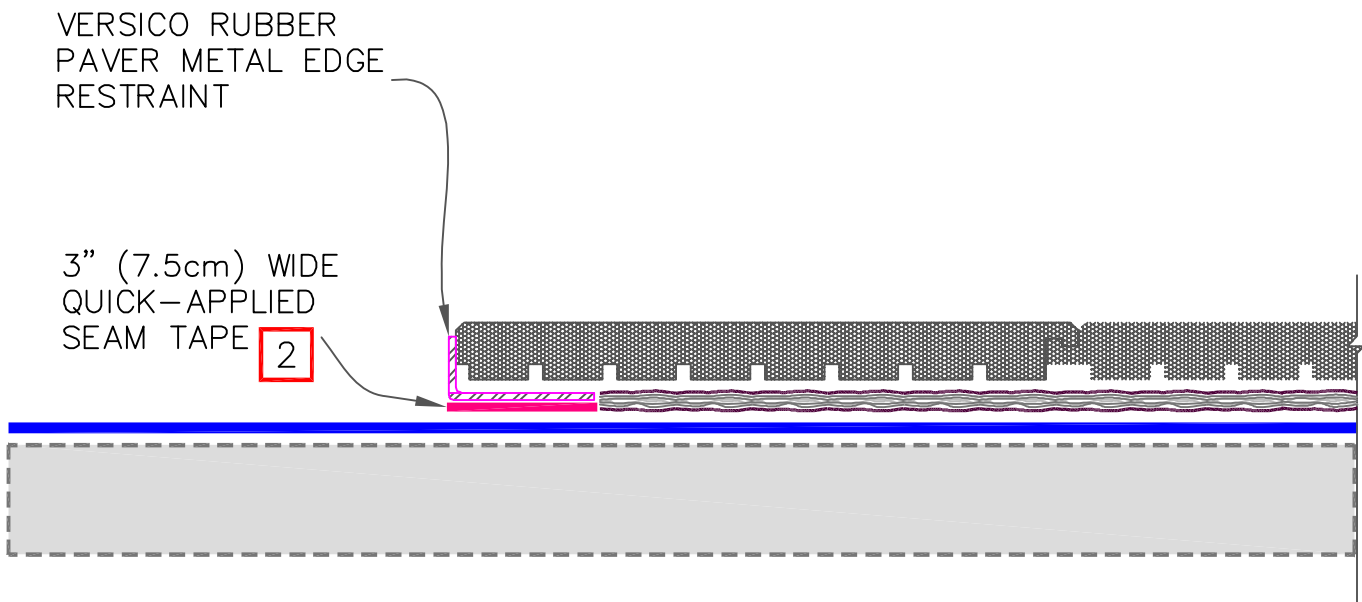

DRAIN DETAIL RUBBER PAVER	
2022 PAVER DETAILS	DETAIL NO. PDI R6.1



NOTES:

1. RUBBER PAVER EDGE RESTRAINT SHOULD BE USED TO TERMINATE THE RUBBER PAVERS WHEN NOT BUTTED TO A PARAPET WALL OR FIXED CURB
2. RUBBER PAVER EDGE RESTRAINT IS ADHERED TO MEMBRANE USING APPLICABLE PRIMER AND QUICK-APPLIED SEAM TAPE. QUICK-APPLIED SEAM TAPE SHALL EXTEND 1/4" (1cm) BEYOND EDGE OF METAL EDGE TO PROTECT ROOF MEMBRANE FROM METAL BURRS & CORNERS



-  → EPDM/TPO/PVC
-  → SEE NOTE(S)
-  → HP PROTECTIVE MAT
-  → 300HV PROTECTION FABRIC



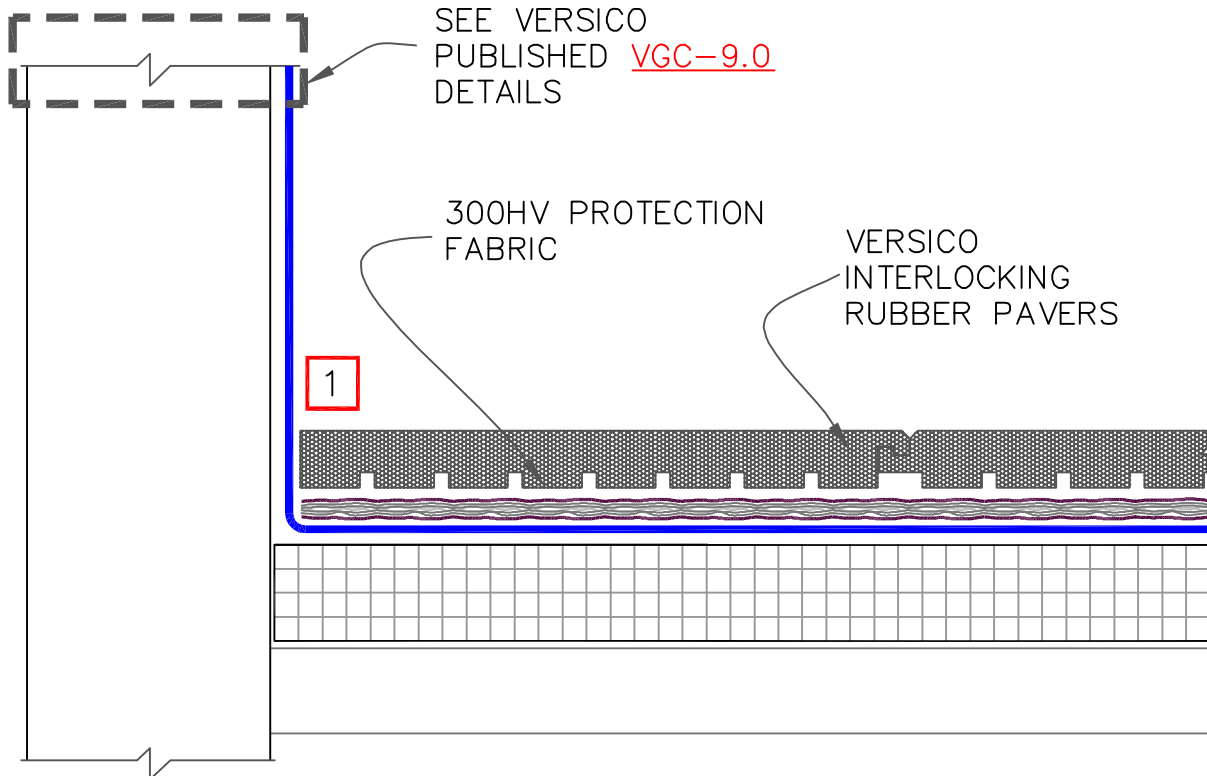

HORIZONTAL TERMINATION AESTHETIC OPTION	
2022 PAVER DETAILS	DETAIL NO. PDIR12.3



NOTE:

1. RUBBER PAVERS SHOULD BUTT TIGHTLY TO PARAPET WALLS. REFER TO VERSICO'S RUBBER PAVER INSTALLATION GUIDE FOR MORE INFORMATION.



-  → EPDM/TPO/PVC
-  → SEE NOTE(S)
-  → HP PROTECTIVE MAT
-  → 300HV PROTECTION FABRIC

PARAPET WALL TERMINATION	
2022 PAVER DETAILS	DETAIL NO. PDIR12.4



SPECIFICATION

SUPPLEMENT

G-17-24

Electronic Leak Detection (ELD) Systems

January 2024

The information contained in this supplement serves as criteria for Specifiers and Authorized Contractors regarding the design and installation of Versico Roofing Systems and related products. Additional information essential for the design and installation of the Roof Systems mentioned herein are also included in the respective Specification for each Roof System and in the Design Reference Section of the Versico Technical Manual. Specifiers and Authorized Contractors are advised to reference all applicable sections.

A. Introduction

Verifying the watertightness of roofing is important, especially if it is to be covered with pavers, ballast, or a vegetated roof assembly. This verification is a field quality-control measure beyond the scope of visual inspections for issuance of a warranty. A common practice used is flood testing the roof using ASTM D5957 as a standard guide. However, using the flood test method can introduce large amounts of water to a new roof assembly if there is a serious leak. Electronic Leak Detection uses a small amount of water, or no water at all, depending on the method used, so the introduction of large amounts of water is not an issue. The advantages of low-voltage electrical conductance testing over traditional flood testing are its capability of providing leak detection throughout the life of the roofing, precisely locating leaks, and with some testing methods, the ability to test sloped roofs and vertical walls. Thereby making it a Quality Assurance test, at time of installation and an Evaluation or Forensic Tool for investigating leaks or breaches in the roof membrane throughout its service life, when the membrane is exposed.

Electronic Leak Detection (ELD) - A non-destructive test that uses a brush, broom, roller, platform, or probes, along with low- or high-voltage electrical current, to find breaches, holes, and seam voids in the roof membrane or flashings by completing a circuit with the electrical charge. In low-voltage ELD testing, A breach-free membrane will block any water and therefore, any electrical current. If a leak is present, the water will make its way through the membrane and must touch an electrically grounded conductive substrate directly below the membrane. This allows an electrical circuit to be completed and the testing equipment and technician to accurately pinpoint the membrane breach, limiting the repairs needed to the areas where damage has been identified instead of replacing or repairing the entire roof.

Electronic leak-testing methods are outlined in **ASTM Guide D7877-14 "Standard Guide for Electronic Methods for Detecting and Locating Leaks in Waterproofing Membranes"** which lists the four different ELD test methods. Those four test methods are: **Low-Voltage Scanning Platform, Low-Voltage Vertical Roller, Low-Voltage Electronic Field Vector Mapping, and High-Voltage Spark or Holiday Testing**. All four of the ELD test methods require the same basic requirements: A conductive substrate must be present directly below the membrane. A valid ground connection must be provided. The membrane must be exposed. The roof system must have a continuous, unbroken electrical path from the top of the membrane to the conductive substrate below.

1. **Low-Voltage Scanning Platform Testing** is a specific system which uses a small scanning platform, called IntegriScan™, a proprietary system by Detec Systems. This system is described in ASTM D7877 as well as in ASTM D8231 "Standard Practice for the Use of a Low Voltage Electronic Scanning System for Detecting and Locating Breaches in Roofing and Waterproofing Membranes". The platform is approximately 18 by 24 inches (457 by 609 mm) and incorporates a perimeter wire loop of chains that hang from the platform and make contact with water on the roof surface, and a separate line of chains located in the center of the platform. Both series of chains are connected to a low-voltage power source. The platform is moved along the surface of the roof

membrane to detect breaches in the roof membrane.

When utilized with a conductive primer directly below the membrane, this system works with electrically conductive roof materials such as black EPDM, which contains carbon black, or with roof membranes that have aluminized protective coatings, commonly used on modified bituminous membranes.

2. **Low-Voltage Vertical Roller Testing** is a specific system which uses a Vertical Scanning Unit (VSU Roller) as part of IntegriScan™, a proprietary system by Detec Systems. This system is described in ASTM D7877 as well as in ASTM D8231 "Standard Practice for the Use of a Low Voltage Electronic Scanning System for Detecting and Locating Breaches in Roofing and Waterproofing Membranes". The VSU Roller utilizes a 3/8" nap by 9" roller. The VSU Roller is moved along the vertical surface of the roof membrane or flashings to detect breaches in the roof membrane or flashings.
3. **Low-Voltage Electronic Field Vector Mapping (EFVM) testing** works by grounding a conductive roof deck, such as steel, beneath a nonconductive roof membrane and locating places where the electric field goes through the roof. This process is accomplished by dampening the roof and placing an uninsulated wire loop around the perimeter of the area to be tested and around any grounded objects to isolate the testing area. The wire loop is connected to a low-voltage pulsating generator that emits a one second 40-V charge every three seconds, creating a momentary electric field between the wire loop and the grounded roof deck. The roof membrane acts as an insulator between the electrified wire loop and the roof deck. Electrical charges over the moist membrane surface will be random unless there is a discontinuity or "leak" in the membrane. If there is a leak, a directional current is created that can be followed to the leak using a potentiometer that is connected to two probes that make contact with the roof surface. For conventional and nonconductive roof decks, such as wood, a conductive medium must be built into the roof assembly. Common mediums include welded stainless-steel mesh for adhered roof systems, a conductive primer for adhered systems, aluminum screen for loosely laid roof systems, and a conductive fabric for use with loosely laid and mechanically fastened roof systems.

Additionally, this testing method will not work with an electrically conductive roof material such as black EPDM, which contains carbon black, or with roof membranes that have aluminized protective coatings, commonly used on modified bituminous membranes. Continuous water contact must be maintained with the perimeter wire, the testing probes and through the breach in the roof membrane to the conductive material (metal roof deck or conductive medium), or the breach will not be detected.

4. **High-Voltage Spark or Holiday testing** uses 1000- to 30,000-Volts of DC power and does not require a wet membrane or perimeter wire loop. The system uses an electrically charged metal "broom" connected to the power source, which is grounded to a conductive roof deck or a conductive medium. When the metal broom passes over a discontinuity in the dry roof membrane, the electrical circuit is completed, and an audible sound and a visible spark is generated by the testing equipment.

Additionally, this testing method will not work with an electrically conductive roof material such as black EPDM, which contains carbon black, or with roof membranes that have aluminized protective coatings, commonly used on modified bituminous membranes. The roof membrane must be completely dry for this testing method to work. Due to the higher voltage used, more false positives have been reported and there is a greater injury risk associated with testing. Additionally, some concern has been expressed with the concept of dragging a wire broom across roof membranes and effect this friction may have on the membrane.

B. Description

The focus of this Spec Supplement is for Electronic Leak Detection with the use of Detec Systems' TruGround Conductive Primer. Versico has collaborated with Detec Systems to offer many Factory Mutual (FM) rated and warrantable roof assemblies that include Detec's TruGround Conductive Primer. Detec Systems' patented TruGround

Conductive Primer is an easy to apply conductive medium that is needed to effectively test conventional roofing assemblies for breaches, holes, and seam voids using electronic leak detection (ELD) methods. ELD has become the preferred option for ensuring a watertight membrane on overburden installations and other critical building projects.

Detec's TruGround Conductive Primer is brush- or roller-applied to the substrate prior to adhesive and membrane application. Once the TruGround Conductive Primer has dried (typically 30 minutes), the bonding adhesive can be applied, and the membrane installed like any other roof system.

For leak detection to be accurate, the conductive medium must be installed directly below the roofing membrane. Alternative conductive mediums often raise concerns regarding membrane adhesion when placed directly below the membrane as required per ASTM D7877. These concerns often lead to improper placement of the conductive medium below a coverboard or insulation which invalidates the ELD testing.

Versico has conducted testing with FM as well as other 3rd party testing agencies to vet roof system performance when TruGround primer is added to the assembly.

The following roof assemblies have been tested and approved by FM with the addition of TruGround. These assemblies are eligible for the same FM rating as they would without TruGround. Contact Versico for associated RoofNav numbers.

FM Approvals		
Membrane Type	Adhesive	Substrates
EPDM	CAV-GRIP 3V	SecurShield Polyiso SecurShield HD Polyiso SecurShield HD Plus Polyiso Dens Deck Prime SECUROCK
TPO	CAV-GRIP 3V	SecurShield Polyiso SecurShield HD Polyiso SecurShield HD Plus Polyiso Dens Deck Prime SECUROCK
PVC	Low-VOC PVC Bonding Adhesive	Versicore Polyiso SecurShield Polyiso SecurShield HD Polyiso SecurShield HD Plus Polyiso

The following roof assemblies have been tested and approved by FM with the addition of TruGround, but are limited to an FM 1-90 rating. Contact Versico for associated RoofNav numbers.

FM Approvals		
Membrane Type	Adhesive	Substrates
VersiFleece	Flexible DASH (splatter method)	VersiCore Polyiso SecurShield Polyiso SecurShield HD Plus Polyiso Dens Deck Prime SECUROCK DuraStorm VSH
VersiFlex PVC	Hydrobond Bonding Adhesive	VersiCore Polyiso SecurShield Polyiso SecurShield HD Plus Polyiso Dens Deck Prime SECUROCK DuraStorm VSH

For projects that are not FM insured, Versico approves and warrants the use of Detec TruGround in all current roof assemblies. Versico warrants that the use of TruGround within the roof assembly will not detrimentally affect the performance of the roof assembly. Roof assemblies using TruGround can achieve the same uplift and warranty terms as the same assembly would be eligible for without TruGround.

C. Quality Assurance

1. The specified roofing system must be installed by a Versico Authorized Roofing Contractor in compliance with drawings and specifications as approved by Versico.
2. Roof system must be inspected and approved by a Technical Representative of Versico prior to Overburden System (Roof Garden, Pavers or Ballast) installation.
3. Do not install this assembly before the concrete deck has reached its' initial structural strength. Project Engineer must be consulted prior to job start-up.

D. Submittals

1. Shop drawings must be submitted to Versico by the Versico Authorized Roofing Contractor along with a completely executed Copy-A Job Approval Request for approval. Approved shop drawings are required for inspection of the roof and on projects where on-site technical assistance is requested.
2. Upon completion of the installed work, submit copies of the manufacturer's final inspection to the specifier prior to the issuance of the manufacturer's warranty.

E. Products

1. In addition to the products listed below, products listed in "Part II" of the Versico Thermoset/Thermoplastic/VersiFleece Roofing System Specification can be used as part of the Overburden System (Roof Garden, Pavers or Ballast) installation.
 - a. Detec TruGround Conductive Primer - is a water-based, liquid-applied, electrically conductive primer that enables effective electronic leak detection (ELD) testing of conventional roof assemblies. Detec TruGround is brush- or roller-applied in a single-sided application to any properly prepared, non-conductive horizontal or vertical surface such as plywood, insulation, or gypsum cover boards. TruGround is compatible with high- and low-voltage ELD testing methods listed in ASTM Standard Guide D7877 and complies with ASTM Standard Practice D8231. TruGround is UL Listed and FM Approved in several Versico roofing assemblies.

F. Execution

Follow current specifications for installing roof membranes and seaming per specific membrane. [VersiGard (EPDM), VersiWeld (TPO) or VersiFlex (PVC/KEE HP)].

G. Installation

1. Start by liberally applying TruGround to the substrate T-Joints using a paint brush, this ensures electrical continuity between boards. If large gaps, those exceeding 1/8", are present between boards, apply seam tape to the T-Joints to act as a bridge, connecting the boards together. Then, when applying TruGround to the substrate boards (see step 2) ensure that it is also applied over the seam tape connecting the boards. Seam tape may need to be applied at vertical penetrations as well, if the gaps are too large to bridge with TruGround.
2. Apply a thin coat of TruGround over the entire project area using a 3/8" nap roller. If the surface is black, TruGround has been applied at the acceptable thickness. Coverage rate is typically 1250 square feet for most non-porous substrates.
3. Continue TruGround up and onto all metal/grounded penetrations a minimum of 1", not to exceed the height of the flashing. Testing equipment will be connected to these penetrations while conducting the ELD tests.
4. Once TruGround is dry to the touch (typically 30 minutes), proceed with installing the roofing system as outlined in the assembly tables within this Spec Supplement and in accordance with Versico published Specifications for the specific membrane type.

H. Associated System Diagram

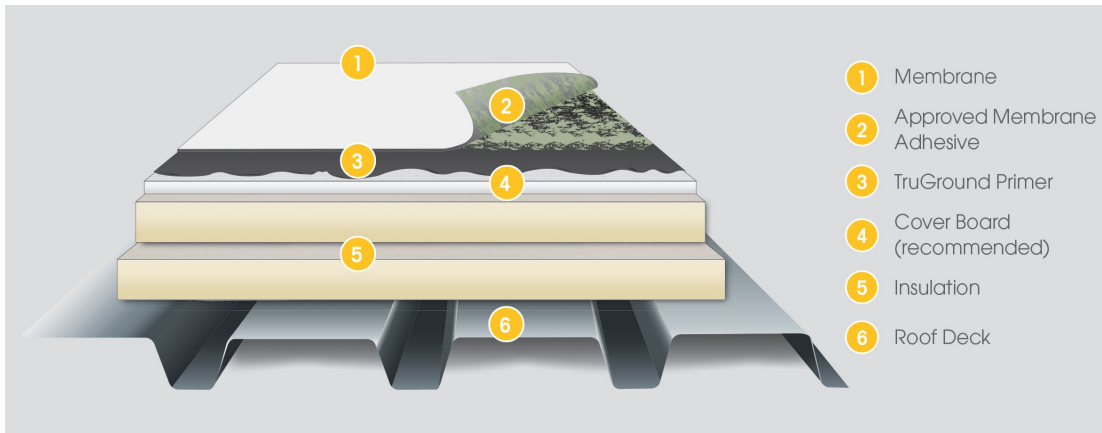

Typical Roof Assembly with Conductive Primer

End of Section

Copyright 2024 Versico
Versico, VersiGard, VersiWeld and VersiFlex are Trademarks of Versico

TruGround is a Trademarks of Detec Systems

This specification represents the applicable information available at the time of its publication. Owners, specifiers and Versico Authorized Roofing contractors should consult Versico or their Versico Independent Sales Representative for any information, which has subsequently been made available.

Review the appropriate Versico warranty for specific warranty coverage, terms, conditions and limitations.



SPECIFICATION

SUPPLEMENT

P-01-22

Related Versico Products

January 2024

In addition to products included in the various roofing specification sections, Products listed herein are available from Versico and when used as part of the roofing system, they will be covered by the Versico warranty. Additional information concerning these products can also be found on individual Technical Data Bulletins or the Versico website.

A. Edgings

Refer to [Spec Supplement G-10-18 “Metal Edging and Details”](#) for various product listings.

B. **Termination Bar:** A 1" wide and 98-mil thick extruded aluminum bar pre-punched 6" on center which incorporates a sealant ledge to support Lap Sealant and provide increased stability for membrane terminations.

C. **VersiTrim Term Bar Fascia:** A 1.75" wide formed aluminum termination bar with pre-slotted fastening holes for ease of locating and installing. The decorative cover is available in 0.040" aluminum or 24-gauge galvanized steel. VersiTrim Term Bar Fascia is manufactured in 12' lengths for fewer joints/seams, fewer sections to handle and faster installation.

D. Versico Vapor Retarder and accessories

1. **Versico's VapAir Seal 725TR Air and Vapor Barrier** - A 40-mil thick composite consisting of 35-mil self-adhering rubberized asphalt membrane laminated to an 5-mil UV resistant poly film with an anti-skid surface which is fully compatible with Flexible DASH Adhesive. VapAir Seal 725TR can also function as a temporary roof for up to 120 days. Available in rolls 39" wide by 100' long (325 square feet).

Technical Data – Versico VapAir Seal 725TR Air and Vapor Barrier		
Property	ASTM	Results
Thickness	D-1970	40 mils
Tensile Strength	D-412	250 psi
Elongation (1)	D-412	250%
Peel Adhesion	D-903	5 lbs./in.
Puncture Resistance	E-154	60 lbs.
Permeability	E-1970(2)	0.015 perms
Air Permeance	E-2178	0.000L/s*m2 @ 75 Pa
(1)Rubberized asphalt compound only.		
(2)D 1970 is tested to E96 standards for permeability.		

2. **Versico's VapAir Seal MD Air and Vapor Barrier** – a reinforced composite aluminum foil with self-adhesive SBS backing and removable poly release film. Used for direct application over metal decks. Available in rolls 42.5" wide by 131.23' long (460 square feet).

Technical Data – Versico VapAir Seal MD Air and Vapor Barrier		
Property	ASTM	Results
Thickness	D-5147	15 mils
Tensile Strength	D-412	250 psi
Elongation	D-1970	330%
Peel Adhesion	D-903	14 lbs./in.
Puncture Resistance	D-5602	54.6 lbs.
Permeability	D-1970(1)	0.03 perms
Air Permeance	E-2178	0.000L/s*m2 @ 75 Pa
(1) D1970 is tested to E96 standards for permeability.		

3. **CCW-702 or 702LV Primer** - A single component, solvent based, high tack primer used to provide maximum adhesion between Versico725TR Air and Vapor Barrier and an approved substrate. Applied by spray or long nap roller with a coverage rating ranging from approximately 300 to 350 square feet per gallon on smooth finishes (i.e., concrete) to 75 square feet per gallon on porous surfaces (i.e., DensDeck Prime gypsum board). Available in 5-gallon containers. CCW-702LV Primer contains less than 250g/L VOCs and meets South Coast Air Quality Management District (SCAQMD) and Leadership in Energy and Environmental Design (LEED) Requirements for Volatile Organic Compounds. Available in 5-gallon containers.

Technical Data – Versico 702 Primer		702 LV Primer
Property	Results	Results
Weight Per Gallon (lbs)	7.7	7.5
Solids Content (% by weight)	38%	46%
VOC Content	540 g/l	Less than 250 g/l
Color	Blue	Plum Red
Flash Point	-4° F	-4° F
Adhesion to Concrete (1b/lin. In.)	7	11

4. **CCW-702WB** – a high-tack, water-based contact adhesive for promoting adhesion of Versico air/vapor barrier membranes and an approved substrate (i.e., concrete, Dens-Deck Prime and Securock). Applied by roller, brush or spray with an application rate of approximately 200 sq. ft. per gallon. Available in 5-gallon containers. CCW-702WB Primer contains 57g/L VOCs and meets South Coast Air Quality Management District (SCAQMD) and Leadership in Energy and Environmental Design (LEED) Requirements for Volatile Organic Compounds.
5. **CAV-GRIP 3V Low-VOC Adhesive/Primer:** a Low-VOC, methylene chloride-free adhesive that can be used for a variety of applications including: bonding VersiWeld membrane to various surfaces, enhancing the bond between Versico’s VapAir Seal 725TR and various substrates, priming unexposed asphalt prior to applying Flexible DASH Adhesive and for adhering VersiWeld/VersiFlex VersiFleece and VersiGard EPDM or VersiWeld TPO membrane to vertical walls and horizontally, for the field of the roof. Coverage rate is approximately 2,000-2,500 sq. ft. per #40 cylinder and 4,000-5,000 sq. ft. per #85 cylinder as a primer, in a single-sided application; 750 sq. ft. per #40 cylinder and 1,500 sq. ft. per #85 cylinder as an adhesive for vertical walls, in a double-sided application; 1,000 sq. ft. per #40 cylinder and 2,000 sq. ft. per #85 cylinder as an adhesive, horizontally, for the field of the roof, in a double-sided application.

6. **VapAir Seal Flashing Foam:** a low-pressure foam system that utilizes a non-flammable blowing agent. VapAir Seal Flashing Foam has been specifically formulated for flame retardancy and conforms to the requirements of ASTM E84 as a “Class 2(B)” system (flame spread of 75 or less, smoke development of 450 or less). The foam is used to seal penetrations and helps to lower heating and cooling costs by reducing air leakage.

VapAir Seal Flashing Foam Packaging and Yields		
Size	41 lbs packaging	115 lbs packaging
Board Feet	205 (19m ²)	605 (56.2m ²)
Linear Feet - 1" Bead	3,132	9,236
Linear Feet - 2" Bead	783	2,309
Note: Yields are based on cured material.		

E. Daylighting Products and Accessories

1. Skylights

- a. **SunPath:** A tubular daylighting system, consisting of roof dome, reflective tube, and diffuser assembly that meet the following specifications and whose configuration will be indicated as per drawings:
1. Roof Dome Assembly: Transparent, UV and impact resistant dome with flashing supporting dome and top of tube.
 - a) Outer Dome Glazing: 0.177 inch (4.5 mm) minimum thickness impact resistant acrylic classified as CC2 material. Visible light transmission minimum 92 percent.
 - b) Flashing Base: One piece, seamless, leak-proof flashing functioning as base support dome and top of tube.
 - c) Base Material: Aluminum, .80 thickness, 9 inches (229 mm) high.
 2. Reflective Extension Tube: Aluminum sheet, thickness 0.02 inch (0.508 mm).
 - a) Interior Finish: high reflectance specular finish on exposed reflective surface. Visible spectrum greater than 97 percent.
 3. Dual Glazed Diffuser Assembly:
 - a) Upper glazing: Acrylic plastic classified as CC2 material. The nominal thickness is 0.060 inches.
 - b) Lower glazing: Acrylic plastic classified as CC2 material. The nominal thickness is 0.090 inches (2.29 mm).
 4. The skylight dome is vacuum formed from 100% modified impact acrylic that is seal locked onto an aluminum dome ring. Accessories include electric dimmer systems, lighting inserts, and security grills. Available in 5 diameter sizes: 10", 13", 18", 21", and 24".
- b. **SunWeld:** A factory assembled conventional skylight consisting of plastic glazing welded in place by a 6063-T5 extruded aluminum retaining angle and resting on an extruded aluminum inner frame. This product can be manufactured to any specified size or to fit existing curbs based on field dimensions and offers several glazing options including acrylic, polycarbonate, copolyester, fiberglass & prismatic acrylic. These units can be integrally attached to an insulated self-flashed metal curb and can be incorporated into the Versico Total Roof System warranty when a Versico system is being installed.

Size of Rough Opening	Size of Outside Curb Dimension
48" x 48"	51.50" x 51.50"
48" x 60"	51.50" x 63.50"
48" x 72"	51.50" x 75.50"
48" x 84"	51.50" x 87.50"
48" x 90"	51.50" x 93.50"
48" x 96"	51.50" x 99.50"
60" x 72"	33.50" x 75.50"

- c. **SunWeld Plus Dynamic Dome:** Available in 18 standard sizes, the Dynamic Dome is an innovative product that balances the structural demands of industry professionals with an architecturally progressive design. Engineered to closely match the angles of the sun during low-light periods to harvest more sunlight to transfer indoors, the Dynamic Dome offers uncompromising strength and a visually stunning design. These units can be integrally attached to an insulated self-flashed metal curb and can be incorporated into the Versico warranty when a Versico Roofing system is being installed.
2. **SunWeld Heat/Smoke Vents**-Two types are available as follows: the **Drop-Out** option is glazed with a special heat sensing material that when activated, softens the glazing material and releases it from the retainer frame, venting smoke and gas. The **Mechanical** smoke vent is a fusible link-activated, spring loaded assembly that initiates the venting process with activation temperatures that range from 165° up to 500°. Sizes (both self-flashed and curb mount).
3. **Pre-Fabricated Metal-Factory curbs** shall be assembled, self-flashing units with all corners mitered and welded; 1" thick polyiso insulation shall be sandwiched between the outer shell and inner liner and a wood nailer shall be provided at the top of each side. Standard curbs shall be 12.00" tall with a 3.00" wide horizontal flashing flange at the bottom. Standard curbs shall be metal and offered as three types:
- Galvanized Steel – 18 gauge outer shell and 20-gauge inner liner.
 - Structural Galvanized Steel - 14 gauge outer and-20 gauge inner liner.
 - Mill Finish Aluminum – .050 outer shell and .025 inner liner.
4. **Skylight Accessories**
- Flashing Boots (Sleeves)**-For roof curbs, this flashing accessory is manufactured from the applicable membrane material (PVC/TPO), and can accommodate all curb types.
 - Quick-Applied EPDM Curb Flashing**-Available for use with EPDM roof membrane installations.
 - Security Grills/Fall Protection Screens**-Available for use with the skylights as deterrents to break-ins as well as to help meet OSHA safety requirements.
 - Metal Deck Support Kit**-An installation accessory that provides skylight structural support and facilitates the metal deck retrofit installation process.

- e. **Curb Adapter**-Serves as a structural transition piece that can either reduce or extend existing curb dimensions in order to accommodate the installation of standard Drylight sizes on existing curbs and still allow the Drylights to be included under the Versico Total Roof System Warranty. Curb adapters are manufactured from minimum 18-gauge Mill Finish Aluminum and shall be assembled with all corners mitered and welded. Adapters are insulated with 1.00" thick high density fiberglass insulation with a white plastic waterproof facer attached.

F. Other Products

1. **Versico GreenGuard PB6 Fanfold Roof Recover Board:** A high-density 3-lb density extruded polystyrene (XPS) foam core with 3-ply film facers on both sides for use as a recover board. Available 3/8" thick and 4' x 50' (2 squares) and weights 20 lbs per unit.
2. **Versico Type VI Felt:** A heavyweight fiberglass mat containing heat-cured resinous binders saturated with Type IV asphalt. The Type VI felt is heavier weight than a Type IV giving the felt additional breaking strength and dimensional stability. The Type IV felt can be mopped or cold applied over a nailed base sheet or two plies mopped over a concrete or approved surface achieving a vapor/air retarder. Available in rolls 36" wide and 180' long (540 square feet). Meets ASTM D2178 and UL-G1.
3. **Versico Type IV Felt:** A heavyweight fiberglass mat containing heat-cured resinous binders saturated with Type IV asphalt, giving the felt excellent breaking strength as well as dimensional stability. The Type IV felt can be mopped or cold applied over a nailed base sheet or two plies mopped over a concrete or approved surface achieving a vapor/air retarder. Available in rolls 36" wide and 180' long (540 square feet). Meets ASTM D2178 and UL-G2.
4. **FR Base Sheet 1S:** A non-asphaltic fiberglass-based underlayment that meets or exceeds ASTM D226 or D4869 Type I or II performance. In conjunction with Hot Mopped Systems, the FR Base Sheet can be incorporated to provide a suitable substrate for deck types requiring a fastened base. Available 4' x 250' roll (1000 square foot) weighing 0.09 lbs per square foot.
5. **SureMB G2 Base Sheet:** A non-porous 28 pound base sheet uniquely designed and constructed to be strong while remaining wrinkle resistant. Versico's SureMB G2 Base Sheet is typically mechanically attached (using Versico approved fasteners) to the light concrete, gypsum or tectum substrate as the first ply and subsequent layers of G2 base sheet, Type IV or Type VI Glass felt is mopped or cold applied to the base-ply to achieve a vapor/air barrier. Available in rolls 36" wide and 108' long (324 square feet). Meets ASTM D4601 Type II and UL-G2.
6. **SureMB Vented Base:** A heavyweight venting base sheet constructed from a fiberglass mat coated with weathering-grade asphalt which meets ASTM D4897 Type II and UL-G2. Typically used as a venting base sheet over lightweight insulating concrete or gypsum decks, used in conjunction with Versico Dual Prong Base Sheet Fastener. Available in rolls 39-3/8" wide and 33' long (100 square feet) and weighing 0.86 lbs per square foot.
7. **SureMB 70 SA Base Ply:** 70-mil smooth surface, self-adhered base ply. Reinforced with a fiberglass mat that is saturated and coated with asphaltic bitumen and SBS elastomer and meets ASTM D6163 Type 1, Grade S. 70 SA is designed to be used as a base ply or interplay in Versico's multiple-ply system and can be used as an air and vapor barrier or temporary (up to 60 days) roof.
8. **SureMB 90TG Base:** 94-mil smooth-surfaced, SBS, torch-applied membrane. Reinforced with a fiberglass mat that is saturated and coated with asphaltic bitumen and SBS elastomers which meets ASTM D6163 Type I, Grade S. SureMB 90TG is designed for use as a base-ply or inter-ply in Versico's multiple-ply system and can be used as an air barrier, vapor barrier or temporary (Up to 60 days) roof. Available in rolls 39-3/8" wide and 49'-1" long (164 square feet) and weighing 0.57 lbs per square foot.
9. **SureMB 90 Base Ply:** 90-mil Glass fiber, reinforced, SBS-modified asphalt, base sheet that meets ASTM D 6163 Type I, Grade S for SBS-modified bituminous sheet materials. May be used as an air barrier,

vapor barrier and temporary (Up to 60 days) roof. Available in 39-3/8" wide and 49'-1" long (161 square feet) weighing 0.58 lbs per square foot.

10. **SureMB 120TG Base:** 120-mil smooth-surfaced, torch-grade SBS base ply, reinforced with a non-woven polyester mat that is saturated and coated with asphaltic bitumen and SBS elastomers that meets ASTM D6163 Type I, Grade S for SBS-modified bituminous sheet materials. Designed for use as a base-ply or inter-ply in Versico's multiple-ply system and may be used as an air barrier, vapor barrier or temporary (Up to 60 days) roof. Available in 39-3/8" wide and 32'-9" long (107 square feet) weighing 0.79 lbs per square foot.
11. **Versico Dual-Prong Fastener:** A factory pre-assembled, 1.8" long fastener consisting of a precision tube formed from galvanized (G-90) coated steel, a 2.7" diameter disk formed from Galvalume (AX-55) coated steel, and a locking staple of high tensile steel wire. Used to secure base sheets to cementitious wood fiber, lightweight concrete, and gypsum providing 70 lbs. of pullout resistance is achieved (40 lbs. Min.).
12. **Lite Deck Fastener:** An oversized diameter fastener and associated 3" Lite-Deck Metal Plate for use on Fully Adhered Roofing Systems to attach insulation to gypsum decks.
13. **Expansion Joint Supports:** A high quality formed EPDM expansion joint support for use with all VersiGard EPDM roofing systems; available in two profiles for use at expansion joints within the field of the roof and along parapet walls.
14. **HP Splice Wipes:** Used in conjunction with Splice Cleaners or EPDM Primer to clean membrane prior to splicing or applying Lap Sealant.
15. **Versico Interlocking Rubber Pavers:** A 2' by 2' by 2" thick rubber paver weighing approximately 24 pounds per unit, 6 pounds per square foot manufactured from recycled rubber, which provides a resilient, shock absorbing, weather resistant surface. Designed primarily for use as a walkway or on terrace areas offering a unique, environmentally sound advantage over concrete pavers. Features include freeze/thaw stability, bi-directional drainage and no breakage concerns. Available in black and terra cotta.
16. **SpeedTite Drains:** Retrofit roof drain with a one-piece seamless body and extra-large flange (17") for positive attachment to roof flashing. Built-in Vortex breaker technology which is designed to provide improved flow performance. Available in 3" and 4" sizes.
17. **Hercules Insert Drains:** Retrofit roof drain with a one-piece spun aluminum body and heavy-duty cast aluminum strainer dome and clamping ring. Designed for use in EPDM, TPO, and PVC. Available in 3", 4", 5" and 6" sizes with a 12" long drain stem.
18. **Olympic Pipe Support System:** A non-penetrating support system designed to carry piping, conduit, ductwork and elevated walkways across the roof or to support equipment such as air conditioners on the roof.
19. **X-Tenda Coat Acrylic Coating:** A water-based color coating used with EPDM membrane. Available in standard colors of white and gray.
20. **SecurTaper:** An ergonomic equipment innovation designed to provide a means for tape seam application that is efficiently driven, user friendly and quality enhancing.
21. **6" QA Flashing Applicator:** Similar in concept to the SecurTaper only used to apply Quick-Applied Flashing.
22. **Stand Up Seam Roller:** A 6" wide by 2" diameter roller and 62" long handle with a 45° bend. Allows splices to be rolled in an ergonomic stand-up position.
23. **APEEL Cover Tape Applicator:** A 6" wide by 2" diameter roller and 62" long handle with a 45° bend.

Allows splices to be rolled in an ergonomic stand-up position.

24. **Other Accessories Available:** 6" blade heavy-duty scissors and 2" wide steel hand rollers.
 - a. **Expansion Joint Supports:** A high quality extruded EPDM expansion joint support for use with all VersiGard EPDM (Black and White on black), VersiWeld TPO, VersiFlex PVC and KEE HP Roofing Systems; available in two profiles for use at expansion joints within the field of the roof and along parapet walls.
 - b. **Other Accessories Available:** 6" blade heavy-duty scissors and 2" wide steel hand rollers.

G. Insulation Adhesive

1. **Flexible DASH Adhesive:** A spray (full coverage) or bead-applied, two-component polyurethane, construction grade, low-rise expanding foam adhesive used for attaching VersiFleece Membranes or approved insulations to compatible roof decks (concrete, cellular lightweight insulating concrete, gypsum, cementitious wood fiber, wood or steel) or existing smooth or gravel surfaced BUR, modified bitumen or cap sheets.
2. **Versico's Flexible DASH in Dual Cartridge, Dual Tank and 5-Gallon Jug Adhesive:** A two component (Part A and B), extrusion applied, low rise adhesive for attaching approved insulation to compatible roof decks.
3. **OlyBond 500 BA and Spot Shot:** A two-component, polyurethane construction grade, low-rising expanding adhesive designed for bonding insulation to various substrates. Applied in 1/2" to 3/4" beads or ribbons using a portable 1:1 applicator (oversized, dual-cartridge caulking gun). **Refer to the Technical Data Bulletin for bead spacing with reference to building height.**

H. Miscellaneous

1. **Versico Seam Probe:** A hand tool used to check the integrity of heat welded seams on heat welded roofing systems. The probe has a heat-treated tip and the handle is tapped to fit standard threaded extension handles allowing the tool to be used from a standing position.

I. Accessory Vents

1. **VersiWeld TPO T-Top Vent:** Constructed using 60-mil TPO Detail Membrane, which provides enhanced flexibility and allows for the elimination of T-Joint Covers at three-way membrane intersections. White in color and manufactured in standard sizes of 4", 6", and 8". Additional sizes and colors are available on a special-order basis.
2. **VersiFlex™ PVC T-Top Vent:** Constructed using 60-mil PVC KEE HP Membrane, which provides excellent long-term weathering protection. White in color and manufactured in standard sizes of 4", 6", and 8". Additional sizes and colors are available on a special-order basis.
3. **VersiWeld TPO Square Top Vent:** Constructed using 60-mil TPO Detail Membrane, which provides enhanced flexibility and allows for the elimination of T-Joint Covers at three-way membrane intersections. White in color and available in a nominal size of 8". Additional colors are offered on a special-order basis. Custom sizes of Square Top Vents are not available.
4. **VersiFlex™ PVC Square Top Vent:** Constructed using 60-mil PVC KEE HP Membrane, which provides excellent long-term weathering protection. White in color and available in a nominal size of 8". Additional colors are offered on a special-order basis.
5. **Non-Weldable One- and Two-Way Pressure Relief Breather Vent:** 8" tall, spun aluminum vent with a base diameter of 11" and stack diameter of 5". Engineered to allow moisture and air to escape from within the roofing system. May be used in conjunction with Versico's DeckVent EPS Insulation for a roof assembly

over Lightweight Structural Concrete (See [Spec Supplement G-15-19](#)) or in conjunction with VersiFleece AC (EPDM and TPO) membranes over Lightweight Insulating Concrete (See [Spec Supplement G-04-19](#)).

6. **Weldable One- and Two-Way Pressure Relief Breather Vent:** 5.5" tall, stainless steel vent with a 60-mil weldable flange, a base diameter of 14" and stack diameter of 4". Engineered to allow moisture and air to escape from within the roofing system. May be used in conjunction with Versico's DeckVent EPS Insulation for a roof assembly over Lightweight Structural Concrete (See [Spec Supplement G-15-19](#)) or in conjunction with VersiFleece AC (EPDM and TPO) membranes over Lightweight Insulating Concrete (See [Spec Supplement G-04-19](#)).

Copyright 2024 Versico

Versico, VersiTrim and VersiGard are Trademarks of Versico
Olybond is a Trademark of OMG, Inc.

This specification represents the applicable information available at the time of its publication. Owners, specifiers and Versico authorized roofing contractors should consult Versico or their Versico Independent Sales Representative for any information, which has subsequently been made available.

Review the appropriate Versico Warranty for specific warranty coverage, terms, conditions and limitations.



SPECIFICATION

SUPPLEMENT

T-01-23

Heat Welding Equipment Use & Procedures Thermoplastic Membranes

January 2024

The information contained in this supplement serves as a criteria for Specifiers and Authorized Contractors regarding the design and installation of Versico Roofing Systems and related products. Additional information essential for the design and installation of the Roof Systems mentioned herein are also included in the respective Specification for each Roof System and in the Design Reference Section of the Versico Technical Manual. Specifiers and Authorized Contractors are advised to reference all applicable sections.

A. Automatic Heat Welder

An electrically powered, self-propelled device that utilizes an electrical resistance heating element or heater and fan-forced super heated air to weld membrane seams.

1. Temperature Settings

- a. When making a VersiWeld TPO/VersiFlex PVC splice, no one temperature setting or speed can be used to describe the temperature setting or speed to set the robot. The splice must be tested to determine the quality of the splice.
- b. Consult the respective heat welding machine manufacturer for recommendations concerning proper temperature setting and speed control of their equipment.
- c. Typically, the colder the ambient temperature (and likewise the membrane temperature) the slower the Automatic Heat Welder speed control must be adjusted to produce proper seams.
- d. As a general guide, depending on the length of the nozzle, **VersiWeld** membranes will weld at a lower temperature 1004° F (540° C) and faster speed (12 feet to 18 feet per minute) than most other heat welded membrane materials. **VersiFlex** membrane will weld at a temperature of 1094° F (590° C) and a speed of 8 feet to 12 feet per minute.
- e. Using an Automatic Heat Welder, the suggested starting point for welder set up is 1004° F (540° C) at 12.5 feet per minute for VersiWeld OR 1094° F (590° C) at 10.4' per minute for VersiFlex. Refer to automatic heat welder manufacturer's recommended temperature and speed to obtain the correct splice results.
- f. The following is a list of items to be checked to determine the temperature setting and the speed at which a splice should be completed:
 - 1) When the membrane is in direct sunlight, the temperature or robot speed may have to be adjusted when moving into a shaded area, check the splice results. Remember the membrane surface in a shaded area will be cooler than a membrane surface that is in sunlight. Darker colored membrane (such as gray) will be warmer than white and may affect the welder speed.
 - 2) Dampness on the membrane from dew, a passing rain shower or misting condition will reduce heat from the splice due to evaporating moisture from the membrane surface. The heat welding temperature (increased) or the robot speed (slower) will have to be adjusted to produce a good splice. Water must be wiped from the welding surface prior to welding the splice.
 - 3) Wind has a cooling affect as it blows over the surface. It will also affect the airflow in the splice

reducing the effectiveness of the hot air gun. This will require the operator to increase heat from the hot air gun or reduce the welder speed.

- 4) Substrates make a substantial difference in the amount of heat required to produce a proper heat welded splice. The robot will have to be adjusted accordingly:
 - a) Plywood and Concrete act as heat sinks and will take a higher temperature or slower speed setting than insulation.
 - b) Cool damp substrates will take a higher temperature or slower speed setting than dry substrates.
- 5) Membrane “bleed-out” from sheets should occur with VersiFlex membrane if properly welded. If bleed-out is not occurring (the underside of the membrane begins to melt and flow), the welder speed should be decreased to increase welding temperature.

2. Equipment Set-up

- a. Equipment set up is the responsibility of the Authorized Contractor. When poor welding is occurring check the following:
 - 1) If the membrane is overheated on one side or the other, check the nozzle to be sure it is distributing the heat evenly between the two sheets.
 - 2) If the heat is bypassing the edge of the sheet producing a cold weld along the edge of the splice, be sure the nozzle is completely under the sheet and the air dam is in place and functional.
 - 3) If the probed splice is tight at the edge but a cold weld is present in center of the splice (the heat is melting the edges but does not melt the center of the splice), check to be sure the robot is not running too fast.
 - 4) Ensure the silicone pressure wheel is intact with no voids in the silicone. If voids are present, incomplete welding will result.
 - 5) Be sure all wheels on the air dam are not binding. Binding wheels will cause sheet movement and distortion during the welding process.
 - 6) The automatic heat welder nozzle should be adjusted as close to the pressure wheel as possible. If the nozzle is too far away from the pressure wheel, distortion of the membrane may occur due to heat expansion.

NOTE: Adjust welder nozzle so the curved portion (heel) extending outside the seam area does not contact or drag on the exposed surface of the membrane. This portion of the nozzle should be 1/16" to 1/8" above membrane surface.

- 7) Overheating the membrane will cause poor welds. It is recommended the automatic welder be run not less than 8' a minute on average temperature days.
- 8) Only on very cold days the welder should be run below this speed. The temperature and welder speeds must be determined based on test welds prior to actual sheet welding.
- 9) Clean screen of dirt and debris on air inlet of heat gun every day. Accumulation of contaminants on screen will reduce air flow and heat output of welder.

3. Membrane Welding

- a. Prepare the Automatic Heat Welder and allow it to warm for approximately 5 to 10 minutes to reach operating temperature.
- b. Position the Automatic Heat Welder properly prior to seaming with the guide handle pointing in the same direction the machine will move along the seam.
- c. Lift the overlapping membrane sheet and insert the blower nozzle of the Automatic Heat Welder between the overlap. Immediately begin moving the machine along the seam to prevent burning the membrane.

- d. Weight plates provided on Automatic Welders must be utilized.
- e. Proceed along the seam ensuring that the small guide wheel in front of the machine aligns with the edge of the top membrane sheet. Guide the machine from the front only.

CAUTION: Ensure the power cord has plenty of slack to prevent dragging the machine off course (which could result from a tightly stretched cord).

- f. At all splice intersections, roll the seam with a silicone roller to ensure a continuous heat welded seam (the membrane should be creased into any membrane step-off with the edge of the silicone roller). A false weld may result due to surface irregularities created by multiple thicknesses of VersiWeld/VersiFlex membrane sheets..

When using **60-mil or 80-mil** VersiWeld TPO Membrane or VersiFlex PVC Membrane, a **TPO/PVC "T" Joint Cover** must be applied over all "T" joint splice intersections.

- g. To remove the Automatic Heat Welder from the finished splice, stop the movement of the machine and immediately remove the nozzle from the seam area.
- h. Mark the end of the heat welded seam with a water-soluble marker for easy identification. A Hand Held Welder will be necessary to complete the weld in the area between where the Automatic Heat Welder is stopped and restarted.
- i. Perform a test weld, at least, at the start of work each morning and afternoon. Test welds should be made if any changes in substrate or weather conditions occur.

4. Preventing Membrane Creeping During Welding

- a. The operator of the robot must apply foot pressure to the membrane, kicking and sliding the membrane under the robot to keep the membrane tight. Always have the operator stand on the unfastened sheet of membrane to prevent sheet movement.
- b. Do not release foot pressure from the membrane until the pressure wheel rolls over the membrane in front of the foot that is holding the membrane in place.

5. Use of Welding Tracks

- a. Set welding tracks lengthwise along the splice, close to the Automatic Heat Welder air dam to reduce membrane movement caused by the welding process. The operator must continue to apply foot pressure to the welding tracks to help hold the membrane splice in place. Welding tracks are moved as welder progresses along seam.
- b. Welding tracks can be:
 - 1) Sheet metal, 22 gauge – 12" wide by 10' long (with rounded corners).
 - 2) Aluminum or steel plates – 1/4" x 3", 4' to 6' long (with rounded corners).
 - 3) Wood planks – 2" x 12" X 4' to 6' long.
 - 4) Heavy plywood – 3/4" x 24" x 8' long.

6. Test Cuts

- a. Perform a test weld at least at the start of work each morning and afternoon.
- b. The test sample should be approximately 1 inch wide and longer than the width of the seam (cut across the heat welded seam).
- c. Peel the test sample apart after it has thoroughly cooled (approximately 10 minutes) and examine for a consistent 1-1/2 inch wide minimum weld. De-lamination of the membrane from the scrim-reinforcement is an indication of a properly welded seam.
- d. Identify the following seam problems to assure seam quality:

- 1) Discolored or scorched membrane – Increase speed or decrease temperature setting if membrane discolors.
- 2) Voids and wrinkles - A proper heat welded seam has no voids or wrinkles and must be at least 1-1/2 inches wide. Refer to Seam Probing procedures outlined below for proper inspection of seam deficiencies.

7. Seam Probing

The use of a Versico Seam Probe, a blunt or dull cotter pin puller is recommended to probe all heat-welded seams. Probing seams must be done once heat welds have thoroughly cooled. Heat welded seams must be probed throughout the day to check seam quality and to make proper adjustments to heat welding equipment. **The repair of deficiencies must be done routinely throughout the day but no later than the end of each workday.**

- a. Allow heat-welded seams to cool thoroughly for approximately 30 minutes. Premature probing can damage warm seams.
- b. Draw probing tool tip along the edge of the heat welded seam. Apply firm pressure to probe the seam junction, but not into the bottom membrane sheet. The tool will not penetrate into the lap area of a properly welded seam.
- c. If the seam-probing tool penetrates into the lap area, mark the seam using a water-soluble marker at the beginning and the end of voids or wrinkles in the seam edge.
- d. Repair seam deficiencies as soon as possible using the hand held welder. Versico recommends that repairs be made the same day they are discovered.
- e. Probe **repaired seams** after they have cooled completely. If the repair is acceptable, wipe off the water soluble marker lines; if not acceptable, repair the seam using standard heat welded overlay procedures.

Note: All laps must be probed each day soon after it has cooled to verify the welder set-up is effective. Particular attention must be given to all membrane intersections and heat-welded seams at insulation joints. In addition, there should be periodic checks (including at the start of each day) to verify good peel strength.

- f. Considerations when probing TPO systems:
 - 1) TPO does not "flow" like PVC. If you observe an area in which you see "flow" of the bottom black ply, scorched areas of detail/flushing membrane, or scorched field membrane welds, these areas should be probed. If these areas are overheated to the point of membrane damage, an overlay repair will be required even if the weld probes successfully.
 - 2) A properly heated field membrane weld will typically have a visual "sheen" approximately 1/2" wide on the bottom sheet at the weld overlap. When walking seams look for the sheen. If it is not present probe to ensure weld quality.
 - 3) TPO seams require a minimum 1.5" weld. Welds less than 1.5" must be overlaid following specification and detail, even if probing does not produce deficiencies.
- g. Considerations when probing PVC Systems:
 - 1) Welds on PVC systems should produce "bleed out". Bleed out refers to the flow of the bottom ply (of the top sheet) outside of the weld. If you do not see bleed out at seam areas, this increases the probability the seam did not receive enough heat when it was welded. Be sure to probe these areas to ensure weld quality.
 - 2) PVC is a "softer" and more flexible membrane than TPO. As such, a different probe should be used than the one used on TPO roofing systems. The PVC probe should have a blunt/dull tip.
- h. PVC seams require a minimum 1.5" weld. If you observe welds which are less than 1.5", these should be overlaid following specification and detail, even if probing does not produce deficiencies

- i. **Apply Cut-Edge Sealant** on all cut edges of the reinforced VersiWeld TPO membrane (where the scrim reinforcement is exposed) **after seam probing** is completed. When a 1/8" diameter bead of Cut-Edge Sealant is applied, approximately 225 – 275 linear feet of coverage per squeeze bottle can be achieved.
 - 1) Cut Edge Sealant is not required on cut edges of VersiFlex PVC membrane (Horizontal or Vertical).
 - 2) Cut-Edge Sealant is not required on vertical VersiWeld splices.

B. Hot Air Hand Welder

1. General

- a. An electrically powered, hand-held device that utilizes an electrical resistance heating element or heater and fan-forced super heated air to heat weld VersiWeld/VersiFlex membrane and flashing. A hand-held **silicone** rubber roller is used in conjunction with the welder to apply the pressure that fuses the heated membrane surfaces to each other.
- b. The hand-held welder is typically used to repair seams, or when the use of the Automatic Heat Welder is inappropriate (such as flashing penetrations and on high sloped surfaces).

2. Hand Held Welder Settings

- a. Temperature setting for hand held welders when used for flashing should be approximately “6” (on a scale from 1 to 10).
- b. Temperature settings for hand held welders when used for membrane should be approximately “8 –10” (on a scale from 1 to 10).
- c. Exact settings will vary based on heat welding membrane type, ambient temperatures, substrate and type of welder.
- d. Silicone roller should be used to apply pressure to the membrane to be welded.

C. Electrical Cords: For generator requirements and maximum length of electrical cords, refer to Generator/Electrical Requirements below.

D. Seam Probing: The probing of heat welded seams is an important step in the application of a VersiWeld TPO/VersiFlex PVC Roofing System. Versico recommends the use of a Versico Seam Probe to probe all heat welded seams. All seams must be probed (**after the seam has thoroughly cooled**) with the appropriate seam probing tool and all deficiencies must be repaired accordingly with a hand held hot air welder no later than the end of each work day.

E. Silicone Rubber Roller: A 2" wide rubber roller used for rolling heat welded splices.

F. Generator/Electrical Requirements

Building power supplies do not typically provide the proper amount of power necessary for consistent heat welding. The use of a portable generator conforming to the following guidelines is strongly advised.

- 1. A **minimum 6500 watt generator** with a minimum output of 210 volts is required **for one Automatic Heat Welder**. Reduced power availability will result if additional equipment is connected to the generator and may result in faulty heat welded seams. GFI (Ground Fault Interrupter) protection is recommended. Additional generators will be required for operating other power tools and hand held heat welders.

Electrical cords (3 conductors) of the maximum length indicated must be used with the corresponding wire as listed below:

Maximum Length	Wire Size
50 foot	#12
100 foot	#10
300 foot	#8

2. **A minimum 3,000 watt generator** may be used to power a maximum of **two hand held heat welders** as long as no other equipment is connected. This generator should service a minimum of 110 volts and be GFI (Ground Fault Interrupter) protected.

Electrical cords (3 conductors) of the maximum length indicated must be used with the corresponding wire as listed below:

Maximum Length	Wire Size
50 foot	#14
100 foot	#12

For extension cords longer than 100', consult an electrician or electrical contractor to ensure proper size of generator and wire.

G. Heat Welding Precautions

1. Check the welding machine set-up to ensure proper alignment of the heating nozzle, air dam, pressure wheels, or moving parts to see they move properly or are free-spinning. Test run the welding machine to ensure it moves forward following a straight line. If the alignment is off, make necessary adjustments.
2. Make sure the air intake is open. Clean out the air intake screen for the blower unit at each start up.
3. Check the machine for worn or broken parts which need to be replaced. Exercise care to protect the pressure wheel from notches or cuts to prevent incomplete sealing of the welded seam.
4. Before the machine is connected to the power source, make sure it is switched off to prevent a power surge that could damage the unit. Turn the unit on and allow the blower/heater unit to warm up for approximately 5 to 10 minutes to reach operating temperature.
5. Clean the heat nozzle with a wire brush to remove any build-up of membrane, as needed.
6. To extend the life of the heating element of the Heat Welding Equipment, always turn the temperature adjustment down so the welder can cool prior to switching the machine off.
7. Follow all care and maintenance instructions recommended by the respective manufacturer.
8. It is recommended that two Automatic Heat Welders and two generators be available at the project site in the event of mechanical failure.

H. Welding Problems/Repairs

1. A Hand Held Hot Air Welder and a 2" wide silicone roller must be used when repairing the membrane. When the entire heat welded seam is to be overlaid, an Automatic Heat Welder may be used.
2. Prior to proceeding with any repair procedure, the area to be repaired must be cleaned and any material which has been exposed approximately 7 days must be prepared with Versico Weathered Membrane Cleaner (VersiWeld TPO) or PVC or KEE HP Membrane Cleaner (VersiFlex PVC). The membrane can typically be repaired up to 6 months to a year with a standard cleaning method. In cases where the standard cleaning method is not sufficient, the following procedures must be used:
 - a. Scrub the area to be welded with a "Scotch Brite" Pad and appropriate Membrane Cleaner.
 - b. Clean all residue from the area to be welded with a Splice Wipe or a clean natural fiber (cotton) rag.
 - c. Weld the new membrane to the cleaned area using standard welding procedures.
3. Voids in welded seams can be repaired using a Hand Held Hot Air Welder and a silicone roller. Depending on conditions, a splice overlay may be required.
4. Position the hand held welder facing into void so hot air is forced between overlapping membranes. Roll the top membrane surface using positive pressure toward the outer edge until the heated membrane surfaces are fused.
5. Exposed scrim-reinforcement (resulting from scorching surface of membrane) and test weld areas must be

repaired by overlaying the damaged area with a separate piece of membrane with rounded corners. The overlay must extend a minimum of 2 inches past the area to be repaired.

6. Probe all edges of the overlay once cooled to ensure a proper weld has been achieved.
7. Seal all cut edges of VersiWeld TPO Membrane with Cut-Edge Sealant. Cut-Edge sealant not required on cut edges of VersiFlex PVC Membrane (horizontal or vertical).

Note: The same overlay repair procedures may be used for punctures in the heat weldable membrane.

Copyright 2024 Versico

Versico, VersiWeld and VersiFlex are Trademarks of Versico

This specification represents the applicable information available at the time of its publication. Owners, specifiers and Versico authorized roofing contractors should consult Versico or their Versico Independent Sales Representative for any information, which has subsequently been made available.

Review the appropriate Versico warranty for specific warranty coverage, terms, conditions and limitations.



SPECIFICATION

SUPPLEMENT

E-01-21

VersiGard Polyepichlorohydrin (ECO/CO) Membrane / Application Procedure

January 2024

Information contained herein represents minimum requirements which must be complied with when overlaying any of Versico's VersiGard (black or white) EPDM roofing systems with Polyepichlorohydrin membrane to protect primary roofing membrane from grease and oil. Building owner or his/her representative must assess and determine the variety of fluids expected to be in contact with membrane and consult Versico concerning their compatibility.

A. Description

The VersiGard Polyepichlorohydrin (ECO/CO) membrane is especially designed to resist hydrocarbons, aromatic solvents, grease and oil and shall be used as an overlayment to protect existing VersiGard (black or white) EPDM membrane against minor or incidental oil spills.

The ECO/CO overlayment membrane is considered a maintenance items and not included under the coverage the warranted membrane roofing system.

1. For overlayment to a fully adhered or mechanically attached roofing system, the ECO/CO membrane adhered with G200SA Substrate Adhesive or Low VOC Bonding Adhesive.
2. When overlaying ballasted membrane (prior to installing the ballast) the ECO/CO membrane may be loose laid and then ballasted
3. At all edges allow a minimum width of 6" for splicing ECO/CO membrane onto the EPDM membrane.
4. In the area where the ECO/CO membrane is to be installed the roof slope shall be a minimum 1/4" in 12".

B. Related Products

1. **Versico Weathered Membrane Cleaner:** A clear, solvent-based cleaner used to clean the EPDM surface necessary for applying primer and VersiGard Lap Sealant. Available in 1 or 5-gallon pails.
2. **Low-VOC Membrane Cleaner:** A low VOC (volatile organic compound) cleaner (100% EPA-exempted solvents) used to loosen and remove dirt and other contaminants from the surface of exposed EPDM membrane prior to applying Versico EPDM Primer. Available in 1 and 5-gallon pails.
3. **G200SA Substrate Adhesive:** A high-strength, yellow colored, synthetic rubber adhesive used for bonding VersiGard (black or white) EPDM membranes to various surfaces. Available in 5 gallon pails.
4. **EPDM x-23 Low-VOC Bonding Adhesive:** A Low-VOC (volatile organic compound) bonding adhesive (less than 250 grams/liter) used for bonding VersiGard/VersiGard White EPDM membranes to various surfaces. Adhesive is available in 5 gallon pails.
5. **Low VOC Bonding Adhesive:** A low VOC (volatile organic compound) bonding adhesive (less than 250 grams/liter) used for bonding VersiGard (black or white) EPDM membranes to various surfaces. Available in 5 gallon pails.
6. **Solvent-Free EPDM Bonding Adhesive:** A solvent free, odor free, non-flammable, low VOC Bonding Adhesive used to adhere EPDM to multiple substrates. This one-sided application adhesive requires

adhesive to be applied to substrate only, when slopes are less than 1". Slopes greater than 1" or vertical substrates may require 2-sided application. When the solvent-free adhesive is specified, authorized applicators must review applicable product installation information listed on the appropriate Technical Data Bulletin.

7. **VersiGard (black) QA Seam Tape:** A 3" or 6" wide by 100' long splice tape used for splicing adjoining sections of ECO/CO to ECO/CO membrane and to EPDM membrane.
8. **VersiGard (white) QA Seam Tape:** A 3" or 6" wide by 100' long, cream colored splice tape used with VersiGard (white) Systems.
9. **Versico V-150 EPDM Primer:** A solvent-based primer used to prepare the surface of EPDM or ECO/CO membrane for application of QA Seam Tape. Available in 1 gallon pails.
10. **Low VOC EPDM Primer** - A low VOC (volatile organic compound) primer (less than 250 grams/liter) for use with QA Seam Tape. Available in 1 gallon pails.
11. **CAV-GRIP 3V Low-VOC Adhesive/Primer:** a Low-VOC, methylene chloride-free adhesive that can be used for a variety of applications including: bonding VersiWeld membrane to various surfaces, enhancing the bond between Versico's VapAir Seal 725TR and various substrates, priming unexposed asphalt prior to applying Flexible DASH Adhesive and for adhering VersiWeld/VersiFlex VersiFleece and VersiGard EPDM or VersiWeld TPO membrane to vertical walls and horizontally, for the field of the roof. Coverage rate is approximately 2,000-2,500 sq. ft. per #40 cylinder and 4,000-5,000 sq. ft. per #85 cylinder as a primer, in a single-sided application; 750 sq. ft. per #40 cylinder and 1,500 sq. ft. per #85 cylinder as an adhesive for vertical walls, in a double-sided application; 1,000 sq. ft. per #40 cylinder and 2,000 sq. ft. per #85 cylinder as an adhesive, horizontally, for the field of the roof, in a double-sided application.
12. **VersiGard Lap Sealant:** A heavy bodied material used to seal the exposed edges of ECO/CO membrane splices. Available in individual tubes.

C. Membrane (Epichlorohydrin (ECO/CO))

1. Cured, non-reinforced (black), 60-mil (1.5 mm) thick ECO/CO compounded Hydrin epichlorohydrin elastomer, which conforms to the minimum physical properties as listed below. The membrane is available in maximum 10' (3.05 m) widths and 50' (15.25 m) lengths.

Physical Property	Test Method	SPEC.(Pass)	Typical
Tolerance on Nominal Thickness, %	ASTM D 412	±10	±10
Tensile Strength, min, psi (MPa)	ASTM D 412	1305 (9.0)	1556 (10.7)
Elongation, Ultimate, min, %	ASTM D 412	200	316
Tear Resistance, min, lbf/in (kN/m)	ASTM D 624 (Die C)	150 (26.3)	263 (46.0)
Resistance to Heat Aging* Properties after 168 hours @ 240°F (116°C) Tensile Strength, min, psi (MPa) Elongation, Ultimate, min, %	ASTM D 573 ASTM D 412 ASTM D 412	1305 (9.0) 1400 (9.6) 150	
Ozone Resistance* Condition after exposure to 100 pphm Ozone in air for 168 hours @ 104°F (40°C) Specimen is at 50% strain	ASTM D 1149	No Cracks	No Cracks
Brittleness Temp., max, deg. F (deg. C)*	ASTM D 746	-20 (-29)	-20 (-29)
Water Vapor Permeability* max, perms (.060" thickness)	ASTM E 96 (Proc. B)	0.1	.042
Oil Absorption * Change in mass, max, % after 7 days immersion in diesel fuel #2 at 158°F (70°C)	ASTM D 471	15	13.5
* Not a Quality Control Test due to the time required for the test or the complexity of the test. However, all tests are run on a statistical basis to ensure overall long-term performance of the sheeting.			

D. Splice Procedure

- Remove dirt and excess dust** from the mating surfaces of both sheets by wiping with a clean rag. Clean the dry splice area of both sheets by scrubbing with Weathered Membrane Cleaner until the mating surfaces are solid black in color with no streaking.
- Apply Primer to achieve a thin, even coat** on both membrane surfaces with Versico V-150 or Low VOC EPDM Primer. Splice area must be uniform in color, streak-free and free of globs or puddles.
Note: Permeation-resistant gloves (that meet ANSI/ISEA 105-2005) are recommended when cleaners or primers are being used.
- Allow** Primer to dry until tacky but does not transfer to a dry finger touch.
- Unroll** approximately 3' of QA Seam Tape. Align release film with marked line and press tape down to bottom sheet using firm, even, hand pressure. Continue for the length of the splice. Tape roll ends must be overlapped 1". Allow top sheet to rest on release film on backside of tape.
Note: A minimum of 1/8" to a maximum of 1/2" of tape must extend beyond the splice edge.
- Pull** release film from QA Seam Tape beneath the top sheet and allow the top sheet to fall freely onto exposed tape.

6. **Roll** the top sheet onto the mating surface and assemble the seam with hand pressure by wiping toward the splice edge. Roll the splice with a 2-inch wide steel roller, using positive pressure toward the outer edge of the splice.
7. **Clean the dry** splice edge with Weathered Membrane Cleaner.
8. **Apply** a 5/16-inch diameter bead of VersiGard Lap Sealant to completely cover the splice edge and feather.

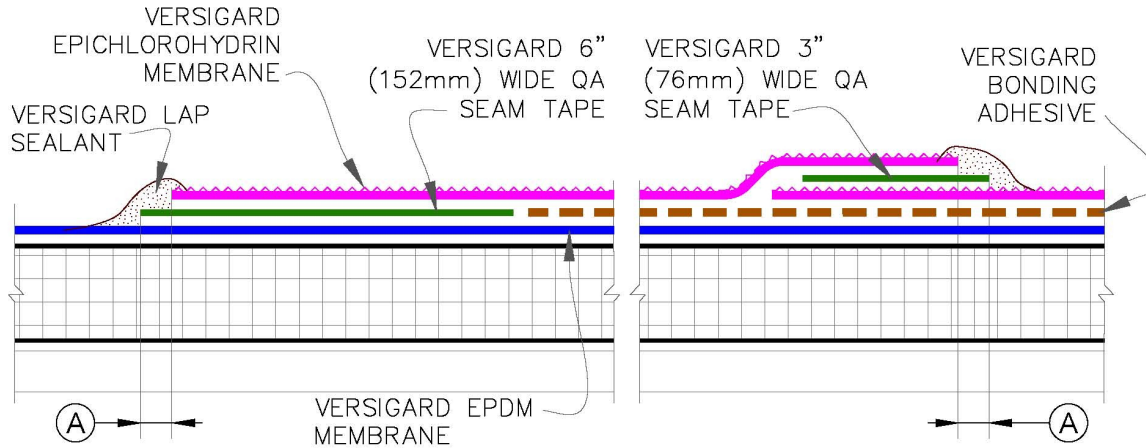

DIMENSION	mm		DIMENSION	mm			
(A)	1/8"	3	MIN.	(A)	1/2"	13	MAX.

Copyright 2024 Versico
 Versico and VersiGard are Trademarks of Versico

This Spec Supplement represents the applicable information available at the time of its publication. Owners, Specifiers and Versico authorized roofing contractors should consult Versico or their Versico Independent Sales Representative for any information that has subsequently been made available.

Review the appropriate Versico Warranty for specific warranty coverage, terms, conditions and limitations.



SPECIFICATION

SUPPLEMENT

E-02-20

EPDM Membrane Splicing and Splice Repairs (Including VersiFleece and VersiFleece AC Membrane)

January 2024

The information contained represents guidelines to address possible requirements as part of the building specification as listed under the Quality Assurance or Performance Article. Versico recommends that the building owner retain a design professional to verify that these guidelines are appropriate.

A. General

1. Fully Adhered or Ballasted Roofing Systems

a. Projects with 10, 15 and 20 year Warranties – [Detail VGC-2.1A](#)

Side Laps / End Laps: Tape splices must be a minimum of 2-1/2" wide using **3" wide field-applied Quick-Applied Seam Tape OR 3" factory-applied Quick-Applied Seam Tape (QAT)**. ([Detail VGC-2.1A](#)).

Splice Intersections: 'T'-Joints are to be flashed with a bead of lap sealant and 6"x6" minimum Quick-Applied 'T'-Joint Cover, (for membranes of maximum thickness of 75 mil). ([Detail VGC-2.1A](#)). **For membranes of thickness of 90 mil**, Apply a second layer of 12"x12" Quick Applied 'T'-Joint Cover centered over 6"x6" or 7"x9" 'T'-Joint Cover. ([Detail U-2A.1– Option 2](#)).

Note: A minimum 6"x6" section of Quick-Applied Uncured Flashing may be used as a 'T'-Joint cover. Quick-Applied Uncured Flashing is available in rolls of 6", 9" and 12".

b. Projects with 25 and 30 year warranties – [Detail VGC-2.1A](#)

OPTION 1:

Side Laps / End Laps: Tape splices may be a minimum **3" wide Factory-Applied QA Seam Tape (VersiGard QAT)**. In addition the entire field splice must be overlaid with a continuous 6" wide Quick Applied Overlayment Strip. (See [Detail VGC-2.1A -Option 1](#)).

Splice Intersections: Overlay the entire field splice with a continuous 6" wide Quick-Applied Overlayment Strip. Apply Lap Sealant at all Intersections between Quick-Applied Overlayment Strip. (See [VGC-2.1A -Option 1](#)).

OPTION 2:

Side Laps / End Laps: Tape splices may be a minimum of 5-1/2" wide using **6" wide Factory-Applied QA Seam Tape (VersiGard QAT)**. ([Detail VGC-2.1A – Option 2](#)).

Splice Intersections: 'T'-Joints are to be flashed with a bead of lap sealant and 6"x6" minimum Quick-Applied 'T'-Joint Cover. Apply a second layer of 12"x12" QA 'T'-Joint Cover centered over 6" x 6" QA 'T'-Joint Cover. ([Detail VGC-2.1A – Option 2](#)).

Note: A minimum 6"x6" section of Quick-Applied Uncured Flashing may be used as a 'T'-Joint cover. Quick-Applied Uncured Flashing is available in rolls of 6", 9" and 12".

2. VersiGard Reinforced Mechanically Attached Roofing Systems

a. Projects with 10, 15 and 20 year Warranties – [Detail VGMA-2.1](#) and [VGMA-2.2](#)

Side Laps: Regardless of Warranty duration, where fastening plates are placed, shall be spliced using **6" wide Factory-Applied QA Seam Tape (VersiGard QAT)** or **6" wide Field-Applied QA Seam Tape**. The splice tape shall be centered over the plates to extend approximately 2" on each side. QA Seam Tape must extend approximately 1/8" beyond the edge of the overlapping membrane. ([Detail VGMA-2.1](#)).

End Laps: Shall be spliced using a **3" wide QA Seam Tape** resulting in a minimum splice width of 2-1/2" for a maximum of 20 year warranties. ([Detail VGMA-2.2](#)).

Splice Intersections: 'T'-Joints are to be flashed with a bead of lap sealant and 6"x6" QA 'T'-Joint Cover. ([Detail VGMA-2.1](#)).

b. Projects with 25 and 30 year Warranties – [Detail VGMA-2.1A](#) and [VGMA-2.2](#)

Side Laps: Where fastening plates are placed, shall be spliced using **6" wide Factory-Applied QA Seam Tape (QAT) OR 6" wide Field-Applied QA Seam Tape**. The splice tape shall be centered over the plates to extend approximately 2" on each side. QA Seam Tape must extend approximately 1/8" beyond the edge of the overlapping membrane. ([Detail VGMA-2.1A](#)).

End Laps: Shall be spliced using **6" wide Factory-Applied QA Seam Tape (QAT) OR 6" wide Field-Applied QA Seam Tape** resulting in a minimum splice of 5-1/2" wide for a maximum of 30 year warranties. ([Detail VGMA-2.2](#)).

Splice Intersections: 'T'-Joints are to be flashed with a bead of lap sealant and 6"x6" QA 'T'-Joint Cover. Apply a second layer of 12"x12" QA 'T'-Joint Cover centered over 6"x6" QA 'T'-Joint Cover. ([Detail VGMA-2.4](#))

3. VersiFleece AC EPDM Mechanically Attached

a. Projects with 10, 15 and 20 year Warranties - [Detail AC-MA1](#)

Side Laps, the tape splices may be a minimum of 5-1/2" wide using 6" wide **Field-Applied QA Seam Tape OR 6" Factory-Applied QA Seam Tape (VersiGard QAT)**. ([Detail AC-MA1](#)).

End Laps: A minimum of 6" wide Quick Applied cured Coverstrip or Quick Applied Overlayment Strip shall be used at all end laps and shall be centered over the leading edge (butt edge) of the splice. ([Detail AC-MA1](#)).

Splice Intersections: All intersections between the Quick Applied Coverstrip and side laps shall be overlaid by a 6"x6" minimum Quick Applied 'T'-Joint cover with a bead of Lap Sealant. ([Detail AC-MA1](#)).

Note: A minimum 6"x6" section of Quick-Applied Uncured Flashing may be used as a 'T'-Joint cover. Quick-Applied Uncured Flashing is available in rolls of 6", 9" and 12".

B. Splicing Procedures

1. **Set the Membrane** – Overlap the EPDM membrane a minimum 2 1/2" or 5 1/2" (63 or 138 mm) to coincide with the QA Seam Tape width. Stagger factory seams on dusted EPDM to avoid a double thickness of membrane. For sheets without a pre-printed set mark, place a set mark 1/8" to 1/2" (3-13 mm) beyond the

leading edge of the top membrane when field applying QA Seam Tape. Locate field splices outside of drain sumps. The pre-marked line on the membrane edge can also be used as a guide for positioning splice tape.

Note: Refer to Step 5 for position of membrane with Factory-Applied Tape.

2. **Clean the Splice Area** - The entire membrane surface where QA Seam Tape will be applied must be clean and free of any residual mica dust or dirt. QA Seam Tape will not adhere to dusted or dirty surfaces.
 - a. Remove loose mica dust on dusted EPDM by brooming or wiping with a clean, dry rag or HP Splice Wipe. Pay particular attention to removing mica dust at any factory seam step-offs.
 - b. Clean the splice areas with Weathered Membrane Cleaner. This allows for roller application of the primer which improves productivity and decreases potential over drying of the primer. This process is required on membrane that has been exposed for a number of weeks. Change HP Splice Wipes often to ensure mica dust is removed. Permeation-resistant gloves meeting ANSI/ISEA 105-2005 are required for hand protection when cleaners or primers are being used. Allow the Weathered Membrane Cleaner to flash-off before applying primer.

CAUTION: Using rags or Splice Wipes that are saturated with mica dust only serve to move the dust from one area to another.

3. Apply HP-250 or Low-VOC Primer

- a. **Dusted Membrane** - After removing the loose mica as noted above, Roller-apply the primer to the membrane with a 3/8" (9mm) medium nap paint roller achieving a thin and even coat that is uniform in color and free of streaks or heavy spots. Confirm that primer is applied into any factory seam step-offs.
- b. **Pre-Kleened™ Membrane or membrane cleaned with Weathered Membrane Cleaner** - Roller-apply the primer to the membrane with a 3/8" (9mm) medium nap paint roller achieving a thin and even coat that is uniform in color and free of streaks or heavy spots. Confirm that primer is applied into any factory seam step-offs.
- c. Allow the primer to flash-off until it does not transfer to a dry finger touch. Do not allow the primer to over dry.
- d. Install QA Seam Tape shortly after the primer flashes off to maximize bond strength and minimize potential dust contamination.

CAUTION: Due to solvent flash-off, condensation may form on freshly applied primer when the ambient temperature is near the dew point. If condensation develops, the application of primer and QA Seam Tape must be discontinued since proper adhesion will not be achieved. Allow the primer surface to dry and apply a thin freshener coat of primer to the previously coated surface and apply QA Seam Tape when conditions allow. Do not stir LVOC Primer.

4. Field Applied QA Seam Tape

- a. **Unroll** approximately 3' (1m) of QA Seam Tape aligning the tape with the set marks. Use firm and even hand pressure to press the tape down to the bottom sheet along the length of the splice. Overlap tape roll ends 1". A continuous piece of QA Seam Tape must be used at all factory seams and field splice intersections. In warm, sunny weather, keep QA Seam Tape rolls in their box in a shaded area until ready to use.
- b. Rolling the installed QA Seam Tape with a 2"-wide hand roller will reduce the frequency of air blisters in the completed field seam. Crease the QA Seam Tape into any factory seam step-off with the edge of the hand roller.
- c. Allow the top sheet to fall freely onto the poly backing. Ensure that a minimum of 1/8" to a maximum of 1/2" of tape extends beyond the top membrane edge. Trim membrane if necessary.

- d. Pull the poly backing off at a 45 degree angle and use firm hand pressure across the splice towards the outside splice edge mating the top sheet onto the QA Seam Tape.
- e. Immediately roll across the splice with a 2" (50 mm) wide hand roller applying positive pressure. Use the edge of the hand roller to crease the top membrane into any factory seam step-off.

Note: At any QA Seam Tape overlap, apply a 5/16" (8 mm) diameter bead of Lap Sealant 1/2" (12 mm) in all directions from the overlap.

5. Factory Applied QA Seam Tape (VersiGard QAT)

- a. Overlap the Factory Applied Tape membrane a minimum 3" or 6" (75 or 150 mm) to coincide with the QA Seam Tape width. Stagger factory seams on dusted EPDM to avoid a double thickness of membrane.
 - b. Pull the poly backing off at a 45 degree angle and use firm hand pressure across the splice towards the outside splice edge mating the top sheet onto the primed area of the bottom sheet.
 - c. Immediately roll across the splice with a 2" (50 mm) wide hand roller applying positive pressure. Use the edge of the hand roller to crease the top membrane into any factory seam step-off.
6. **Install T-Joint Covers** - At all field splice intersections, follow the cleaning and priming steps listed above and then apply a 5/16" diameter (8 mm) bead of Lap Sealant 1/2" (12 mm) in each direction from the membrane intersection according to [Detail VGC-2.1A](#). Then install a 6" x 6" Quicik Applied T-Joint Cover. For 25 and 30 year warranties and all 90-mil membranes apply a 12" x 12" Quick Applied T-Joint Cover centered over the 6" x 6" QA T-Joint Cover according to [Detail VGC-2.2](#).
7. **Apply Lap Sealant** - Apply Lap Sealant at cut edges of reinforced membrane, splice tape overlaps and Quick Applied T-Joint Covers. Lap Sealant may be applied immediately following the completion of a splice. Feather the Lap Sealant with the specially formed plastic Lap Sealant Tool so the high point or crown is centered over the splice edge. Plastic Lap Sealant Tools are provided in cartons of Quick Applied Uncured EPDM Flashing and cardboard tools are on the top of the Lap Sealant cartons.
8. **Cold Weather Requirements** – installation when temperatures fall below 40°F (4°C)
- a. Hot boxes for jobsite storage must be provided to maintain a minimum QA Seam Tape temperature of 40°F (4°C).
 - b. Heat the primed area of the bottom membrane as the QA Seam Tape or Factory Applied QA Seam Tape (VersiGard QAT) is installed and pressed into place.
 - c. Field applied QA Seam Tape must be rolled with a 2" (50 mm) wide hand roller prior to removal of the release liner when temperatures fall below 40°F (4°C).
 - d. Prior to rolling the splice area with a 2" (50 mm) wide hand roller, apply heat to the topside of the membrane with a hot-air gun. The heated surface should be warm to the touch.

C. Lap Sealant Application

1. **Lap Sealant is required at the following locations:**
 - a. Splice tape overlaps.
 - b. Beneath 6" x 6" T-Joint Covers and around the outer edge.
 - c. Where joints in metal edgings intersect with VersiGard Quick Applied Cured Cover Strip.
 - d. Around all edges of Quick Applied Uncured Flashing, Corners, and Pockets.

- e. Cut edges of reinforced membrane.

2. Procedures

- a. Dusted EPDM must be cleaned 1" (25 mm) on either side of the splice edge using Weathered Membrane Cleaner or EPDM Primer and HP Splice Wipes or a clean cloth.

Note: Weathered Membrane Cleaner is not required when using Kleen EPDM unless accumulated dirt is present.

- b. Apply a 5/16" bead of Lap Sealant centered over the splice edge. Coverage rate is 22 lineal feet per tube.
- c. Feather the Lap Sealant with the specially formed Lap Seal Tool so the high point or crown is centered over the splice edge. Clean the feathering tool occasionally for consistent crowning of Lap Sealant.
- d. Application of Lap Sealant **should be completed each day** to avoid extra cleaning of accumulated dirt.

D. Splice Repairs

1. General

- a. Prior to initiating repairs, the membrane must be cleaned to remove field dirt and other contaminants. Using a scrub brush, scrub the splice areas with warm water and a low-sudsing soap (Spic and Span, Tide, Lestoil). Rinse with clean water and allow to dry prior to applying Weathered Membrane Cleaner or Versico EPDM Primer as required.
- b. Versico's Weathered Membrane Cleaner can be used to prepare membrane exposed to the weather prior to applying Versico EPDM Primer. Using a HP Splice Wipe or natural fiber rag (cotton) with Weathered Membrane Cleaner, scrub the area in a circular motion. Continue cleaning until the surface is a consistent matte black color without streaking.

2. Repairs of Cuts and Tears (Surface Splice)

Repairs to cuts and tears in the membrane must be accomplished by splicing a membrane section over the affected area.

- a. Select a repair membrane, which is the same material as that to be repaired.
- b. Extend the repair membrane section at least 3" in every direction from the cut or tear. Round the corners of the repair membrane prior to splicing. Clean the membrane to remove field dirt and other contaminants as outlined above.
- c. Apply Versico EPDM Primer to the splice areas. Install Quick Applied Cured Cover Strip or Cured Membrane and QA Seam Tape and then hand roll the splice areas. Apply T-Joint Covers at splice intersections. Lap Sealant is applied at flashing and tape overlaps in accordance with standard procedures.

3. Repair of improperly installed Tape Splices

- a. Improperly installed tape splices include, but are not limited to, fishmouths at field splices, lack of or improper use of Primer, condensation formation on Primer or incorrect tape placement, etc.
- b. **If fishmouths are present in the field splice**, the fishmouth must be cut by removing the top layer of membrane prior to overlaying the splice. The flashing overlay **must** be supported by the bottom layer of cured membrane

- c. Clean the splice area with Weathered Membrane Cleaner. Apply EPDM Primer on both sides extending past the width of the new flashing overlay to be installed.
- d. Overlay the defective splice area with a bead of lap sealant overlaid with a minimum 6" wide VersiGard Quick Applied Uncured EPDM Flashing, Cover Strip or Overlayment Strip centered over the edge of the splice. If using Quick Applied Uncured EPDM Flashing, apply Lap Sealant around the outer edge and feather accordingly.

Copyright 2024 Versico

Versico, VersiGard, VersiWeld, VersiFlex and VersiFleece, are Trademarks of Versico

This specification represents the applicable information available at the time of its publication. Owners, specifiers and Versico authorized roofing contractors should consult Versico or their Versico Independent Sales Representative for any information, which has subsequently been made available.

Review the appropriate Versico warranty for specific warranty coverage, terms, conditions and limitations.