



# SECUREDGE XL GUTTER

BOX

## \*NOTES

- Not available in 24 ga. galv. steel or .040" aluminum
- Splice plates and pop rivets provided
- Gutter cannot be cantilevered
- Maximum downspout dimension not to exceed bottom width minus 1-9/16"
- Pre-attached gutter cleat and lower mounting hanger are made out of the same material as the gutter
- Unless otherwise noted, fabrication of miters and accessories are provided with a non-penetrating quicklock joint, then factory sealed watertight
- Welded accessories require minimum material thickness of .050 aluminum.
- For non-90 miters, see separate print approval
- Product should be installed per provided installation instructions
- ANSI/SPRI/GT-1 test pressures up to 266 psf (Horizontal), 291 psf (Vertical), 175 plf (Downward)

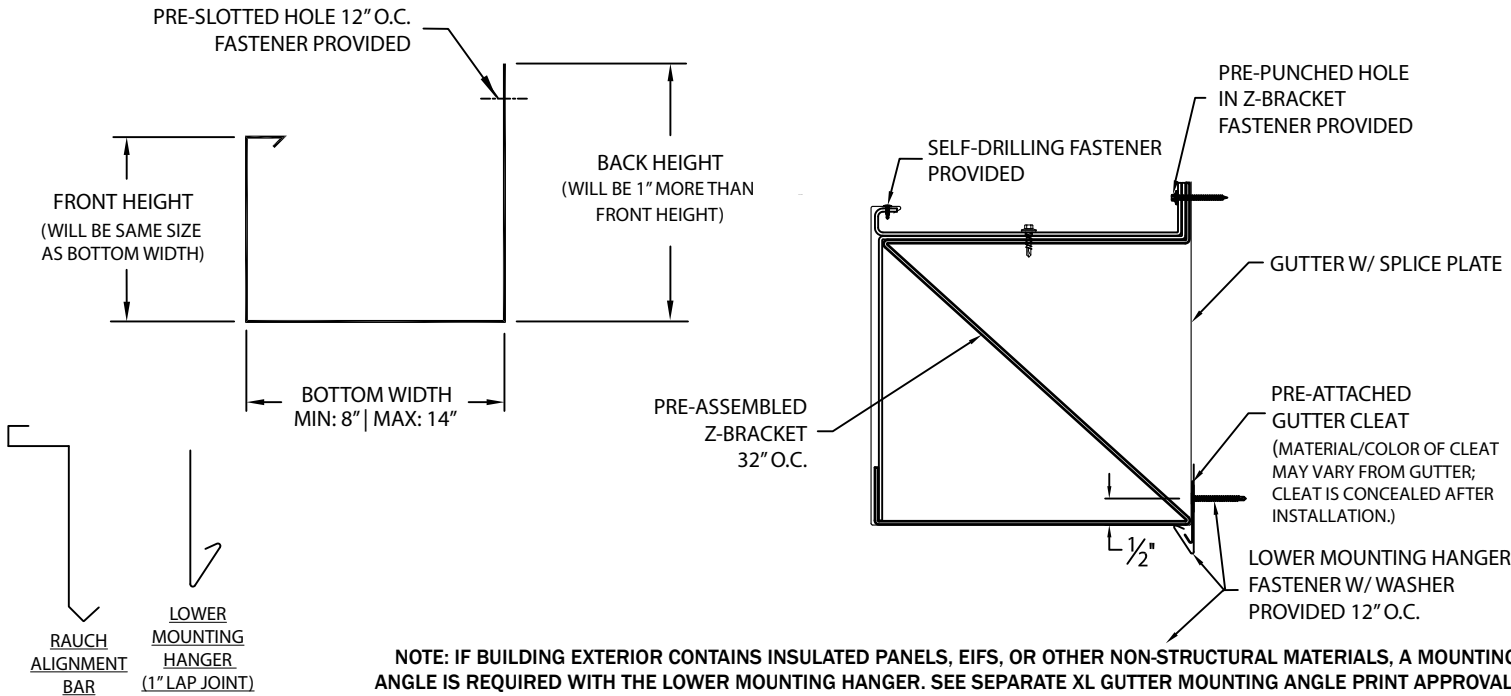

## APPROVALS\*

**ANSI/SPRI/GT-1**  
Test Pressures listed in notes



## PROJECT INFO

Project Name: \_\_\_\_\_

Architect: \_\_\_\_\_

Roofing Contractor: \_\_\_\_\_

### Project Type:

By selecting this box you have verified and confirmed that dimensions, sizes, and quantities are correct. All products will be installed in strict accordance with printed instructions.

Date: \_\_\_\_\_

Customer Service  
800-558-2162  
(Metal-Era)

SHT #: \_\_\_\_\_ of \_\_\_\_\_

DATE: **04/20/26**

DRN BY: **MLM**

CKD BY: **MM**

DWG #: **15012-43851**

REV: **C**

## DIMENSIONS

SELECT SIZE	FRONT HEIGHT	BOTTOM WIDTH	BACK HEIGHT
	8"	8"	9"
	10"	10"	11"
	12"	12"	13"
	14"	14"	15"

## MATERIAL

- 22 Ga. Galv. Steel      Color: \_\_\_\_\_
- .050" Aluminum      Finish: \_\_\_\_\_
- .063" Aluminum      Substrate:
- If substrate is not given, wood fasteners will be provided.
- Wood
- Masonry
- Metal

## QUANTITIES

\_\_\_\_\_ Lineal Feet (12'-0" Lengths)

\_\_\_\_\_ Outside Miter (90°)

\_\_\_\_\_ Inside Miter (90°)

\_\_\_\_\_ Right Endcaps

\_\_\_\_\_ Left Endcaps

Accessory Type\*:    Quicklock (Default)    Welded (Surcharge)

\_\_\_\_\_ Expansion Joints (Style 1)

\_\_\_\_\_ Expansion Joints (Style 2)