



**AFX EPDM / AFX Sure-Weld® /
 FleeceBACK Sure-Flex KEE HP
 Hot Mopped / Cold Applied Adhered Roofing System**

Table of Contents
 January 2024

| Part I – General | Page |
|---|-------------|
| 1.01 Description | 3 |
| 1.02 Assembly Options | 4 |
| 1.03 General Design Considerations..... | 6 |
| 1.04 Quality Assurance | 7 |
| 1.05 Submittals | 8 |
| 1.06 Warranty..... | 9 |
| TABLE I – Membrane System Warranty Options – 5 YR to 30 YR | 10 |
| TABLE II – Base Sheet Options for Direct Hot Mopped Membrane | 11 |
| TABLE III – Underlayment/Insulation & Required Attachment New Construction/Tear-off – Up to 20 YR | 11 |
| TABLE IV – Direct Application to Existing Roofing Materials – Up to 15 YR Warranty..... | 12 |
| TABLE V – Underlayment/Insulation & Required Attachment Assemblies Hot Mopped – 25/30 YR | 13 |
| 1.07 Job Condition/ Cautions and Warnings | 14 |
| 1.08 Product Delivery, Storage, and Handling | 16 |
| | |
| Part II - Products | |
| 2.01 General | 17 |
| 2.02 Membranes | 17 |
| 2.03 Insulation / Underlayment..... | 20 |
| 2.04 Related Materials | 22 |
| 2.05 Fastening Components | 26 |
| 2.06 Other Products | 27 |
| 2.07 Roof Walkways..... | 29 |
| 2.08 Edging and Terminations | 29 |
| | |
| Part III - Execution | |
| 3.01 General | 30 |
| 3.02 Roof Deck Criteria | 30 |
| 3.03 Substrate Preparation | 31 |
| 3.04 Wood Nailer Installation | 34 |
| 3.05 Base Sheet and Insulation Attachment | 34 |
| 3.06 AFX Membrane Installation | 36 |
| 3.07 AFX Sure-Seal EPDM Membrane Splicing with Factory-Applied SecurTAPE | 38 |
| 3.08 AFX Sure-Weld Heat Welding Procedure | 38 |
| 3.09 Welding Problems / Repairs..... | 40 |
| 3.10 Additional Membrane Securement for AFX Membrane Adhered with Cold Applied Adhesive | 40 |
| 3.11 Flashing Considerations..... | 41 |
| 3.12 Related Products Installation..... | 42 |
| | |
| Attachments | |
| Mechanically-Fastened Option For Recover Application..... | 43 |
| | |
| Installation Details | 47 |



AFX EPDM / AFX Sure-Weld® / FleeceBACK Sure-Flex KEE HP Hot Mopped / Cold Applied Adhered Roofing System

January 2024

The information contained in this generic specification represents a part of Carlisle's requirements for obtaining a roofing system warranty. Construction materials and practices, building siting and operation, climatic conditions, and other site-specific factors will have an impact on the performance of the roofing system. Carlisle recommends that the building owner retain a design professional to determine appropriate design measures to be taken in order to address these factors.

PART I GENERAL

1.01 Description

The Hot Mopped / Cold Applied FleeceBACK AFX or FleeceBACK KEE HP Membrane System incorporates the use of hot mopped (Type III or IV Asphalt, or SEBS Modified Asphalt) or cold applied (Cold Applied Adhesive, an asphalt-modified polyether VOC free adhesive) FleeceBACK AFX (EPDM/TPO) membrane or FleeceBACK KEE HP membrane to recover various existing roof systems. The membrane assembly can also be used for new construction or when existing roofing material is to be removed.

1. FleeceBACK AFX EPDM membranes:
 - a. Sure-Seal AFX EPDM combines 45- or 60-mil Sure-Seal® non-reinforced EPDM membrane with 7.5 ounce per square yard (45-mil thick), non-woven polyester polypropylene blended fleece-backing resulting in a total thickness of 90-mil or 105-mil thick.
 - b. Sure-White (white) AFX EPDM membrane combines 60-mil Sure-White® non-reinforced EPDM membrane with 7.5 ounce per square yard (45-mil thick), non-woven polyester polypropylene blended fleece-backing resulting in a total thickness of 105-mil thick.
2. FleeceBACK AFX Sure-Weld TPO membrane combines 45-, 60- or 80-mil Sure-Weld TPO polyester reinforced membrane with 10 ounce per square yard (75-mil thick), non-woven polyester polypropylene blended fleece-backing resulting in a total thickness of 120-, 135- or 155-mil thick.
3. FleeceBACK Sure-Flex KEE HP membrane combines 50-, 60- or 80-mil Sure-Flex KEE HP polyester reinforced membrane with 7.5 ounce per square yard (55-mil thick), non-woven polyester polypropylene blended fleece-backing resulting in a total thickness of 105-, 115- or 135-mil thick.

Adjoining EPDM sheets are spliced together with Factory-Applied SecurTAPE™ and Primer. Sheet end laps are butted and overlaid with Sure-Seal or Sure-White Cured Cover Strip or Pressure-Sensitive Overlayment Strip.

When TPO or KEE HP membrane is used, adjoining sheets are overlapped and joined with a minimum 1-1/2 inch wide hot air weld. Sheet end laps are butted together and overlaid with Sure-Weld Reinforced Membrane and hot air welded.

Note: As an alternate to the adhered method, the membrane can be mechanically fastened over existing roofing membrane as a recover option with or without insulation. Refer Attachment I at the end of this section.

1.02 Assembly Options

A. Projects with Smooth BUR (Type III or IV Asphalt), Mineral Cap Sheet or SBS Modified Bitumen

FleeceBACK AFX or FleeceBACK KEE HP Membrane adhered with Type III or IV Asphalt, SEBS Modified Asphalt, or Carlisle Cold Applied Adhesive after priming the existing roofing membrane with CCW-550 Cut Back Asphalt. When Cold Applied Adhesive is to be used, power washing the existing membrane is an acceptable alternative to Cut Back Asphalt.

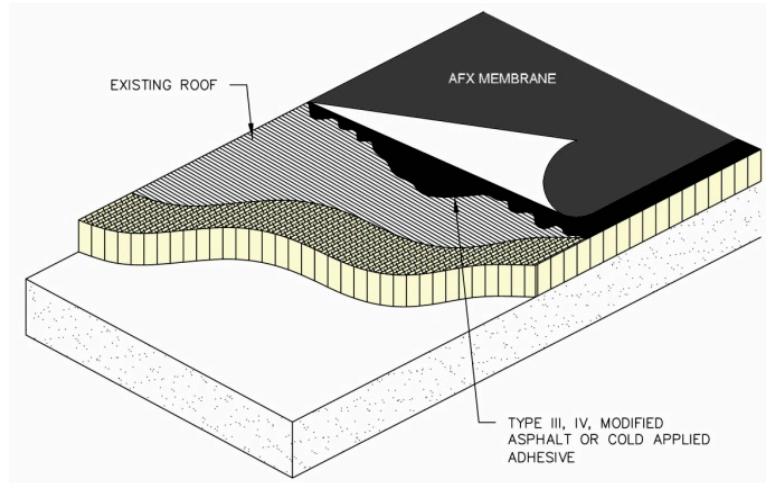

Figure 1

B. Projects with Wood, Gypsum, Lightweight Insulating Concrete, Fibrous Cement (No Insulation)

When FleeceBACK AFX or FleeceBACK KEE HP Membrane is installed over Cellular or perlite based lightweight insulated concrete, one-way vents are required and must be installed at the rate of 1 vent every 2000 square feet.

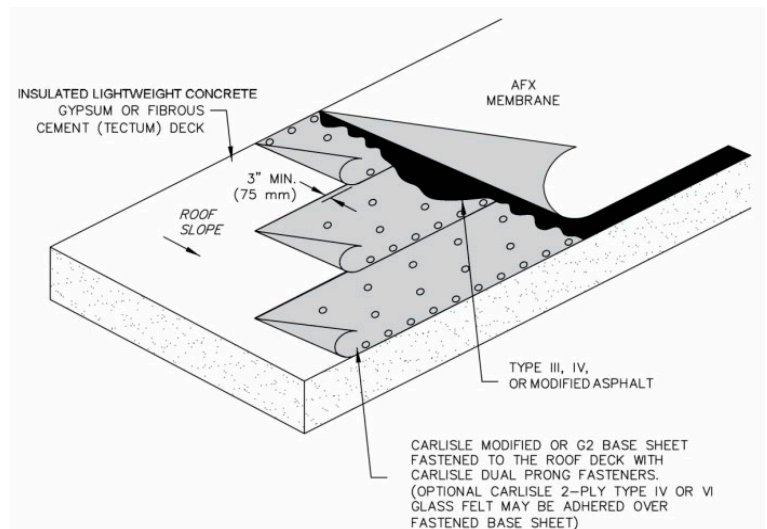

Figure 2

1. When specified, the membrane can be mopped with acceptable asphalt directly to a fastened Carlisle G2 or Modified Base Sheet.
2. Cold Applied Assemblies, the membrane may be adhered directly to a wood, gypsum, or lightweight concrete deck (cellular or perlite based). Over fibrous cement decks Carlisle G2 or Modified Base Sheet must be fastened to the deck.
3. Projects with vermiculite lightweight insulated concrete, FleeceBACK AFX or FleeceBACK KEE HP

membrane must be installed directly over Carlisle G2 Base Sheet prior to mopping the membrane and one-way vents are required. Vents shall be installed at the rate of 1 every 1000 square feet.

C. Projects with Structural Concrete Decks

1. In a Hot Mopped Assembly, the membrane may be applied directly to the deck after the surface has been primed with CCW-550 Cut Back Asphalt Primer. Projects where a two-ply vapor retarder/temporary roof has been specified, the membrane may be mopped directly to Carlisle's Type IV Glass Ply Felt.
2. In Cold Applied Assemblies, the membrane may be adhered directly to the structural concrete.

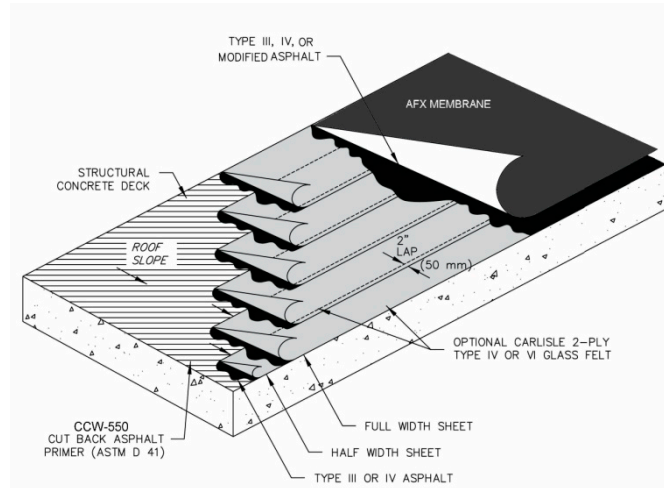

Figure 3

Caution: Curing compounds used in conjunction with structural concrete decks must be compatible with the attachment method and should be investigated. Certain concrete curing compounds develop a seal or oil coating on the concrete's surface that can prevent adhering to the substrate.

D. Projects Where Additional Insulation is Specified

1. General

- a. For Hot Mopped Assemblies, when additional insulation is desired the new insulation must be overlaid with Carlisle 1/2" thick HP Recovery Board, or Securock.
- b. Both new insulation and the membrane underlayment may be mechanically fastened or adhered with either Flexible FAST™ Adhesive or mopped in with Type III / IV or SEBS Modified Asphalt (maximum board size is 4' x 4').
- c. On fluted/corrugated steel decks, insulation cannot be mopped to the steel deck. New insulation must be attached incorporating mechanical securement or Flexible FAST Adhesive.

2. Projects with Gypsum and Fibrous Decks

When mopping insulation to gypsum, fibrous cement and wood decks, Carlisle G2 Base Sheet or Carlisle Modified Base Sheet must be used and shall be fastened to the deck.

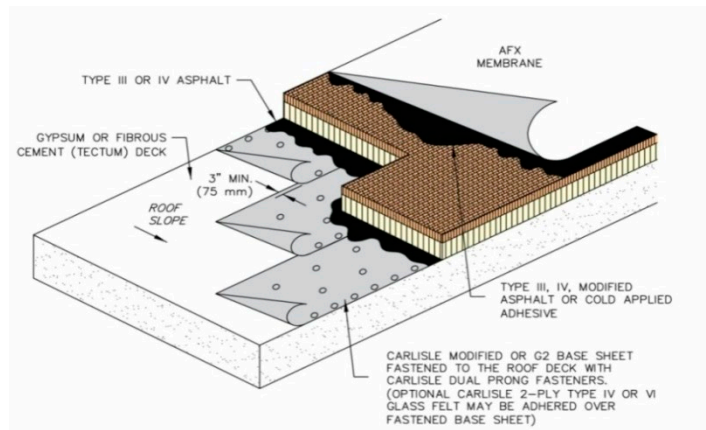

Figure 4

3. Projects with Structural Concrete Decks

On structural concrete decks, when mopping of new insulation is specified, the deck shall be primed with CCW-550 Cut Back Asphalt Primer prior to mopping of insulation boards. As an option, two plies of Carlisle Type IV or VI Glass Felt may be mopped to the primed concrete surface.

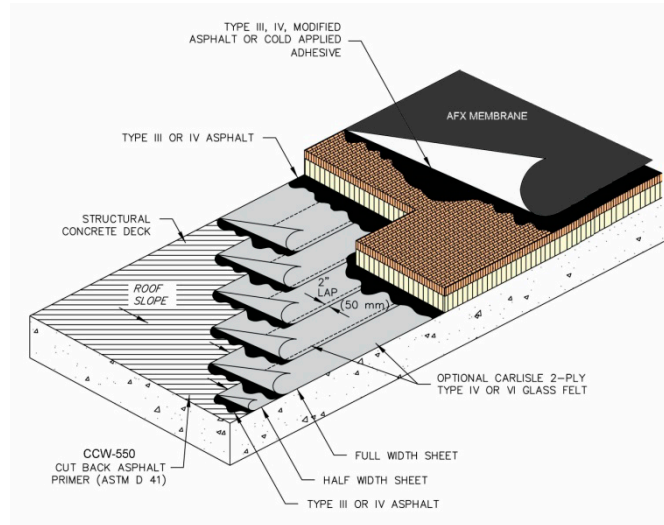

Figure 5

1.03 General Design Considerations

- A. Petroleum based products, certain chemicals and waste products (i.e. grease, oil, animal fats, etc.) are not compatible with this roofing system. Carlisle should be contacted for verification of compatibility and recommendations concerning an acceptable roofing assembly.
- B. It is the responsibility of the Specifiers to review local, state and regional codes to determine their impact on the specified Carlisle Roofing System.
- C. It is the responsibility of the building owner or his/her designated representative to verify structural load limitation. In addition, a core cut may be taken to verify weight of existing components when the roofing system is to be specified on an existing facility.
- D. Coordination between various trades is essential to avoid unnecessary rooftop traffic over completed sections of the roof and to prevent possible damage to the membrane roofing system.
- E. Concentrated loads from rooftop equipment may cause deformation of insulation/underlayment and possible damage to the membrane if protection is not provided. At protection course or sleepers must be specified.
- F. Roof Insulation thickness must be determined by the thermal value required for each project and may be subject to code approval limitations. On projects where a vapor retarder is used, the specifier must calculate insulation thickness to ensure the temperature at the vapor retarder will not fall below the calculated dew point.
- G. Multiple layers of insulation are recommended, with all joints staggered between layers.
- H. For minimum recommended R-Values, previously published by American Society of Heating and Air-

Conditioning Engineers (ASHRAE), consult local building code official for applicable requirements.

- I. On new construction projects, especially in cold climate regions, moisture generated due to the construction process could adversely impact various components within the roofing assembly if not addressed. Refer to [Design References DR-01-21 “Construction Generated Moisture”](#) included in the Carlisle Technical Manual.
- J. Vapor Retarders
 - 1. Carlisle does not require a vapor retarder for the protection of the membrane; however, it should be considered by the specifier for the protection of the roofing assembly (i.e. primarily insulation, underlayment and adhesives). The following criteria should be considered by the specifier:
 - 2. Use of a vapor retarder to protect insulation and reduce moisture accumulation within an insulated roofing assembly, should be investigated by the specifier.
 - 3. In the generally temperate climate of the United States, during the winter months, water vapor flows upward from a heated, more humid interior toward a colder, drier exterior. Vapor retarders are more commonly required in northern climates than in southern regions, where downward vapor pressure may be expected and the roofing membrane itself becomes the vapor retarder.
- K. On structural concrete decks, when a vapor retarder is not used, gaps in the deck along the perimeter and around penetrations must be sealed along with vertical joints between tilt-up panels, if present, to prevent infiltration of hot humid air and possible moisture contamination resulting from condensation.

1.04 Quality Assurance

- A. Building codes are above and beyond the intended purpose of this specification. The building **owner, owner’s representative** or **Specifier** should verify local codes for applicable requirements and limitations. It is the responsibility of the specifier to review local, state and regional codes to determine their impact on the specified Carlisle Roofing System.

NOTE: For code approvals achieved with the Carlisle Roofing Systems, refer to the Carlisle Code Approval Guide, DORA (Directory of Roof Assemblies), Factory Mutual (FM) Approval Guide or Underwriters Laboratories (UL) Fire Resistance or Roofing Materials and Systems Directories.
- B. When recovering or retrofitting an existing roof system, the addition of new insulation (type and thickness) may alter the fire performance characteristics of the assembly. Building owners or their designated representatives shall consult the local code enforcement agency to avoid potential code violation.
- C. Carlisle recommends the use of Carlisle supplied products with this roofing system. The performance or integrity of products by others, when selected by the specifier and accepted as compatible by Carlisle, is not the responsibility of Carlisle and is disclaimed by the Carlisle Warranty.
- D. The solar reflectance of the white membrane may decrease over time due to environmental defacement such as dirt, biological growth, ponded water, etc. The roof should be monitored at regular intervals and maintained or cleaned when necessary to assure the maximum solar reflectance.
- E. This roofing system must be installed by a Carlisle Authorized Roofing Applicator in compliance with drawings and specifications as approved by Carlisle SynTec.
- F. There must be no deviations made from Carlisle's specifications or the approved shop drawings without the **PRIOR APPROVAL** of Carlisle.
- G. After completion of the installation, upon request, an inspection shall be conducted by a Field Service Representative of Carlisle SynTec to ascertain the membrane system has been installed according to Carlisle’s published specifications and details applicable at the time of bid. This inspection is to determine whether a warranty shall be issued. It is not intended as a final inspection for the benefit of the owner.

1.05 Submittals

- A. To ensure compliance with Carlisle's warranty requirements, the following projects should be forwarded to Carlisle for review prior to installation, preferably prior to bid.
1. Projects where building height exceeds 50 feet.
 2. Air pressurized buildings or buildings with large openings where the total wall openings exceed 10% of the total wall area on which the openings are located (such as airport hangars, warehouses and large maintenance facilities).
 3. Cold storage buildings and freezer facilities.
 4. Projects where the membrane is expected to come in direct contact with petroleum based products or other chemicals.
 5. Projects where wind speed warranty coverage greater than 90 mph is specified.
 6. For all projects, prior to inspection by Carlisle, a final shop drawing should be approved. Depending on project complexity and number of roof levels, a project description/profile may be substituted. Contact Carlisle for clarification.
- B. Shop drawings must be submitted to Carlisle by the Carlisle Authorized Roofing Applicator along with a completely executed Notice of Award (Page 1 of Carlisle's Request for Warranty form) for approval. Approved shop drawings are required for inspection of the roof and on projects where on-site technical assistance is requested.

Shop drawings must include:

1. Outline of roof and size
2. Deck type (for multiple deck types)
3. Location and type of all penetrations
4. Perimeter and penetration details
5. Key plan (for multiple roof areas) with roof heights indicated

When field conditions necessitate modifications to originally approved shop drawings, a copy of the shop drawing outlining all modifications must be submitted to Carlisle for revision and approval prior to inspection and warranty issuance.

- C. Notice of Completion (Page 2 of the Carlisle Request for Warranty form)

After project completion, a Notice of Completion must be submitted to Carlisle to schedule the necessary inspection of the project prior to issuance of the Carlisle Warranty.

- D. As-Built Projects (roofing systems installed prior to project approval by Carlisle)

The Carlisle Authorized Applicator may supply Carlisle with an As-Built drawing for a project completed prior to Carlisle's approval. The As-Built drawings:

1. Must conform to Carlisle's most current published specifications and details applicable at the time of bid.
2. Must be submitted along with a completely executed Notice of Completion.

1.06 Warranty

- A. Membrane System Warranty is available for roofing systems on commercial buildings within the United States and applies only to products manufactured or marketed by Carlisle SynTec. The membrane system is defined as membrane, flashings, adhesives, sealants and other Carlisle brand products utilized in the installation. For a complete description of these products, refer to the Part 2 “Products” Section in this specification and [Spec Supplement P-01-18 “Related Products”](#).
- B. See Tables Below for information regarding Warranted Systems and Design Criteria:
1. **Table I – Membrane System Warranty Options - 5 YR to 30 YR.** Identifies minimum membrane thickness for membranes used in hot mopped and cold applied roofing systems.
 2. **Table II – Base Sheet Requirements for Direct Hot Mopped Membrane.** Identifies base sheet options for hot mopped roofing systems.
 3. **Table III – Underlayment/Insulation & Required Attachment New Construction/Tear-off – Up to 20 YR.** Identifies required underlayments for adhered roofing systems with Warranties up to 20 year based on the various wind speed coverages available. The Table also identifies fastening density or adhesive bead spacing and required edge terminations.
 4. **Table IV - Direct Application to Existing Roofing Materials - Up to 15 YR.** Identifies the acceptable existing roofing materials that the FleeceBACK AFX or FleeceBACK KEE HP membrane can be adhered directly to with either asphalt or Cold Applied Adhesive up to 15 year based on the wind speed coverage available.
 5. **Table V – Underlayment/Insulation & Required Attachment Assemblies Hot Mopped 25/30 YR.** Identifies required underlayments for adhered roofing systems with Warranties up to 20 year based on the various wind speed coverages available. The Table also identifies fastening density or adhesive bead spacing and required edge terminations.

Table I Membrane System Warranty Options – 5 Year to 30 Year

General: When FleeceBACK AFX or FleeceBACK KEE HP membranes are adhered directly to an acceptable existing roofing material as shown in Paragraph 1.02.A or to a concrete deck as shown in Paragraph 1.02.C, the application will be limited to Maximum 15 Year Warranty with Peak Gust Wind Speed of 72 MPH. When greater warranty coverage is specified, Carlisle must be contacted to determine any added enhancements.

| Years | Membrane Attachment (3) | | | Minimum Membrane Thickness | Additional Coverage (1) | | |
|-------------------|-------------------------------------|----------------------------|----------------------------|-----------------------------|-----------------------------|-------------------------------|----------------------|
| | 55 or 72 mph | 80 mph | 90 mph | | Accidental Puncture | 1" Dia. Hail | 2" Dia. Hail |
| 5, 10, or 15 year | Type III / IV or Cold Applied | SEBS | SEBS & Modified Base Sheet | FleeceBACK AFX EPDM 90-mil | Up to 8 man-hours per year | Type III / IV or Cold Applied | NA (2) |
| | | | | FleeceBACK AFX TPO 120-mil | NA (2) | | |
| | | | | FleeceBACK KEE HP 105-mil | | | |
| 20 year | Type III / IV or Cold Applied | SEBS | SEBS & Modified Base Sheet | FleeceBACK AFX EPDM 90-mil | Up to 8 man-hours per year | Type III / IV or Cold Applied | NA (2) |
| | | | | FleeceBACK AFX TPO 135-mil | Up to 16 man-hours per year | | SEBS or Cold Applied |
| | | | | FleeceBACK KEE HP 135-mil | | | |
| 25 year | Type III / IV & Modified Base Sheet | SEBS & Modified Base Sheet | NA (2) | FleeceBACK AFX EPDM 105-mil | Up to 16 man-hours per year | SEBS | SEBS |
| | | | | FleeceBACK AFX TPO 155-mil | Up to 32 man-hours per year | | |
| | | | | FleeceBACK KEE HP 135-mil | Up to 16 man-hours per year | | |
| 30 year | Type III / IV & Modified Base Sheet | SEBS & Modified Base Sheet | NA (2) | FleeceBACK AFX TPO 155-mil | Up to 32 man-hours per year | SEBS | SEBS |

- (1) Hail coverage option is available and requires underlayment of HP Recovery Board, or Securock
- (2) NA = Not Available
- (3) See Table III for Underlayment/Insulation Requirements

Table II Base Sheet Requirements for Direct Hot Mopped Membrane

General: When a base sheet is required in Paragraph 1.02 Assembly Options or when it is mandated by Warranty duration, the appropriate Carlisle base sheet must be used as outlined in Table II below. Applications where the base sheet is fastened to wood, gypsum, lightweight insulated concrete, or fibrous cement decks will be limited to Maximum 15 Year Warranty with Peak Gust Wind Speed of 72 MPH. When greater warranty coverage is specified, Carlisle must be contacted to determine any added enhancements.

| Years | Carlisle Type IV or VI Glass Ply Felt | SureMB G2 Base | SureMB Vented Base | SureMB 70 SA Base Ply | SureMB 90TG Base | SureMB 90 Base Ply | SureMB 120TG Base |
|------------------|---------------------------------------|----------------|--------------------|-----------------------|------------------|--------------------|-------------------|
| 5, 10 or 15 year | √ | √ | √ | √ | √ | √ | √ |
| 20 year | √ | √ | √ | √ | √ | √ | √ |
| 25 year | NA | NA | NA | NA | NA | √√ | √√ |
| 30 year | NA | NA | NA | NA | NA | √√ | √√ |

Notes: √√ = Required √ = Acceptable NA = Not Available

Table III Underlayment/Insulation & Required Attachment New Construction/Tear-Off Up to 20 YR

Other Requirements are Listed in Additional Design Considerations following this Table

All Carlisle Products listed for higher wind speed coverage can also be used for Warranties for lower speed coverage. (i.e. 72 MPH underlayment may be used for 55 MPH underlayment)

| Warranty Wind Speed | Hot Mopped | Cold Applied | Minimum Membrane Underlayment | Insulation/Underlayment Attachment | | | | |
|---------------------|------------|--------------|-------------------------------------|--------------------------------------|---|---------------|--|----|
| | | | | Asphalt Fully Mopped 4' x 4' size bd | Adhesive Ribbon Spacing for 4' x 4' size bd | | # of Fasteners for 4' x 8' size bd (6) | |
| | | | | | Field | Perimeter | | |
| 55mph | | √ | 1" (20-psi) Polyiso | Type III or IV | 12" (1)(2) | 6" (1) | 16 | |
| | | √ | 1-1/2" (20-psi) Polyiso | Type III or IV | 12" (1)(2) | 6" (1) | 10 | |
| | | √ | 2" (20-psi) Polyiso | Type III or IV | 12"(1)(2) | 6" (1) | 8 | |
| | √ | √ | 1/2" HP Recovery Bd | Type III or IV | 12"(1)(2) | 6" (1) | 16 | |
| 72mph or 80mph | | √ | 1/4" Securock | Not Recommended | | 12" (1)(2)(3) | 6" (1)(3) | 12 |
| | | √ | 1/2' SecurShield™ HD | 72 mph Type III or IV | 80 mph SEBS | 12" (1)(2)(3) | 6" (1)(3) | 16 |
| | √ | √ | 1/2" HP Recovery Bd | 72 mph Type III or IV | 80 mph SEBS | 12" (1)(2)(3) | 6" (1)(3) | 16 |
| | | √ | 1-1/2" (25-psi) Polyiso | 72 mph Type III or IV | 80 mph SEBS | 12" (1)(2)(3) | 6" (1)(3) | 11 |
| | | √ | 2" (25-psi) Polyiso | 72 mph Type III or IV | 80 mph SEBS | 12" (1)(2)(3) | 6" (1)(3) | 8 |
| | | √ | 2" (25-psi) Polyiso | 72 mph Type III or IV | 80 mph SEBS | 12" (1)(2)(3) | 6" (1)(3) | 8 |
| 90mph | √ | √ | 1/2" Securock | SEBS | | 6" (5) | 6" (3)(4) | 12 |
| | | √ | 1-1/2" (20-psi) SecurShield Polyiso | SEBS | | 6" (5) | 6" (3)(4) | 16 |
| | | √ | 2" (20-psi) SecurShield Polyiso | SEBS | | 6" (5) | 6" (3)(4) | 8 |
| | | √ | 2" SecurShield HD Composite | SEBS | | 6" (5) | 6" (3)(4) | 8 |

Notes:

√ = Acceptable

(1) Gravel Surface BUR - Field @ 6" O.C/ Perimeter @ 4" O.C.

- (2) Steel Decks – Field & Perimeter @ 6" O.C.
- (3) Cementitious Wood Fiber - Field @ 6" O.C/ Perimeter @ 4" O.C.
- (4) Smooth BUR- Field @ 6" O.C/ Perimeter @ 4" O.C.
- (5) Gravel Surface BUR – Full Spray or Ribbons @ 4" O.C.
- (6) For steel, concrete, and wood plank decks.

Additional Design Considerations (Up to 20 YR Warranty)

1. Refer to Table I for minimum membrane thickness.
2. Local Wind Zone as shown in the ASCE 7 shall not exceed 130 mph.
3. All "T-joints" must be overlaid with appropriate flashing material.
4. For ponding locations, seams should be overlaid with pressure sensitive flashing.
5. 1/4" per horizontal foot slope is preferred; however, 1/8" slope with sufficient number of drains and crickets/saddles may be accepted.
6. Carlisle Termination bars are required for replacement of existing counterflashing. SecurEdge™ metal work is recommended.
7. All wet roofing materials must be totally removed.

Table IV Direct Application to Existing Roofing Materials - Up to 15 YR

Other requirements are listed in Additional Design Considerations following this Table.

| Warranty Wind Speed | Existing Roofing Material (2) | Membrane Adhesion | |
|---------------------------|--|------------------------------------|--------------|
| | | Hot Mopped | Cold Applied |
| 55mph or 72mph | Smooth Surface BUR / Mineral Surface Cap Sheet | Direct with Type III or IV Asphalt | Direct |
| | Modified Bitumen | Direct with Type III or IV Asphalt | Direct (1) |

Notes:

- (1) SBS modified bitumen only.
- (2) Refer to paragraph 3.03 for existing material preparation.

Additional Design Considerations (Up to 15 YR Warranty)

1. Refer to Table I for minimum membrane thickness.
2. Local Wind Zone as shown in the ASCE 7 shall not exceed 130 mph.
3. All "T-joints" must be overlaid with appropriate flashing material.
4. For ponding locations, seams should be overlaid with pressure sensitive flashing.
5. 1/4" per horizontal foot slope is preferred; however, 1/8" slope with sufficient number of drains and crickets/saddles may be accepted.
6. Carlisle Termination bars are required for replacement of existing counterflashing. SecurEdge metal work is recommended.
7. All wet roofing materials must be totally removed.
8. Insulation/ cover board will be required for reroofing of Gravel Surface BUR, Coal Tar Pitch, or existing single-ply membrane. Refer to Table III.
9. For 20 year warranty or additional wind coverage, please contact Carlisle for design considerations.

Table V Underlayment/Insulation & Required Attachment Assemblies Hot Mopped 25/30 YR

Cold applied assemblies are not acceptable to for 25 or 30-year warranties

Other requirements are listed in Additional Design Considerations following this Table

All Carlisle Products listed for higher wind speed coverage can also be used for Warranties for lower speed coverage. (i.e. 72 MPH underlayment may be used for 55 MPH underlayment)

| Warranty Wind Speed | Min. Membrane Underlayment | Insulation/Underlayment Attachment | | | |
|---------------------|---------------------------------|---|--|-----------|---|
| | | Asphalt Fully Mopped 4' x 4' size board | Adhesive Ribbon Spacing for 4' x 4' size board | | # of Fasteners for 4' x 8' size board (4) |
| | | | Field | Perimeter | |
| 55 mph | 1/2" HP Recovery Bd or Securock | Type III or IV | 6" (1)(2) | 6" (2) | 16 |
| 72 mph or 80 mph | 1/2" HP Recovery Bd or Securock | SEBS | 6" (1)(2)(3) | 6" (2)(3) | 16 |

- (1) Structural Concrete - Field @ 12" O.C/ Perimeter @ 6" O.C.; 80-mph over structural concrete – Field & Perimeter @ 6" O.C.
- (2) Cementitious Wood Fiber & Wood – Full Spray or Ribbons @ 4" O.C.
- (3) 80-mph over Gypsum Decks – Full Spray or Ribbons @ 4" O.C.
- (4) For steel, concrete, and wood plank decks.

Additional Design Considerations (Up to 30 YR Warranty)

- 1. Refer to Table I for minimum membrane thickness.
- 2. Local Wind Zone as shown in the ASCE 7 shall not exceed 130 mph.
- 3. All "T-joints" must be overlaid with appropriate flashing material.
- 4. For ponding locations, seams should be overlaid with pressure sensitive flashing.
- 5. 1/4" per horizontal foot slope is preferred; however 1/8" slope with sufficient number of drains and crickets/saddles may be accepted.
- 6. Carlisle Termination bars are required for replacement of existing counterflashing. SecurEdge metal work is recommended.
- 7. All wet roofing materials must be totally removed.
- 8. For 25/30 YR Splice Criteria refer to [Spec Supplement E-02-18 "EPDM Membrane Splicing and Splice Repairs"](#)

E. Access for warranty service

It shall be the owner's responsibility to expose the membrane in the event warranty service is required when access is impaired. Such impairment includes, but is not limited to:

- 1. Design features, such as window washing equipment, which requires the installation of traffic surface units in excess of 80 pounds per unit.
- 2. Any equipment, ornamentation, building service units and other top surfacing materials which are not defined as part of this specification.
- 3. Photovoltaic and Mounting Systems or other Rooftop equipment which do not provide Carlisle with reasonable access to the membrane system for purposes of warranty investigation and related repairs.
- 4. Severely ponded conditions.

CAUTION: APPLICATIONS SUCH AS WALKING DECKS, TERRACES, PATIOS OR AREAS

SUBJECTED TO CONDITIONS NOT TYPICALLY FOUND ON ROOFING SYSTEMS
WILL NOT BE ELIGIBLE FOR A SYSTEM WARRANTY.

- F. Industrial pollutants, environmental dirt, and ponding conditions will discolor the surface of a white FleeceBACK AFX or FleeceBACK KEE HP membrane. Lack of additional membrane protection during application will increase the probability of soiling and will affect aesthetics of the roofing system. All these factors will result in minor color variations of the White membrane in comparison to the original undisturbed color. When aesthetics are of importance, the specifier's requirements must be added in the project specifications pertaining to precautionary installation methods and necessary clean up.

Carlisle disclaims responsibility for the cleanliness of discoloration of the membrane system caused by environmental conditions including, but not limited to, dirt, pollutants, or biological agents and discoloration caused by or resulting from initial installation.

- G. The formation or presence of mold or fungi in a building is dependent upon a broad range of factors including, but not limited to, the presence of spores and nutrient sources, moisture, temperatures, climatic conditions, relative humidity, and heating / ventilation systems and their maintenance and operating capabilities. These factors are beyond the control of Carlisle and Carlisle shall not be responsible for any claims, repairs, restoration or damages relating to the presence of any irritants, contaminants, vapors, fumes, molds, fungi, bacteria, spores, mycotoxins, or the like in any building or in the air, land, or water serving the building.

1.07 Job Conditions / Cautions And Warnings

Safety Data Sheets (SDS) must be on location at all times during transportation, storage, and application of materials. The applicator shall follow all safety regulations as recommended by OSHA and other agencies having jurisdiction.

- A. When FleeceBACK AFX TPO or FleeceBACK AFX EPDM (white) membrane are specified, a slope greater than 1/8" per horizontal foot is recommended to serve long-term aesthetics. For FleeceBACK AFX TPO when the roof slope exceeds 5' per horizontal foot, use of an automatic heat welding machine may be more difficult. Hand Held heat welders should be specified.
- B. Asphalt slope restriction for membrane and/or insulation attachment
1. Type III Asphalt maximum roof slope of 1/2" in 12" (4 cm/m).
 2. Type IV or Modified Asphalt can be used for projects with a maximum roof slope of 1-1/2" in 12".
 3. Projects with roof slopes exceeding 1-1/2" in 12" must be submitted to Carlisle for review prior to installation.
- C. Projects where lightweight insulated concrete fill is being removed, new insulation must be mechanically fastened or attached with modified SEBS asphalt after priming the deck surface. Lightweight insulated concrete slurry seals the concrete deck pores and prevents asphalt flowing into them, reducing asphalt attachment and wind uplift performance.
- D. It is the responsibility of the specifier to review local, state and regional codes to determine their impact on this roofing system.
- E. Drainage
1. Drainage must be evaluated by the specifier in accordance with all applicable codes. Slopes may be provided by tapering the structure or through the use of tapered insulation; a sufficient number of roof drains should also be specified and properly located to allow for positive drainage. Significant ponding that could remain after 48 hours should be eliminated with the addition of auxiliary drains in low areas where ponding is anticipated.

Carlisle specifically disclaims responsibility for design and selection of an adequate drainage system and drain accessories. The selection must be made by the building owner or the owner's design professional.

2. Incidental areas of ponded water will not impact the performance of this roofing system; however, in accordance with industry standards, the roofing assembly should be designed to prevent ponding of water on the roof for prolonged periods (longer than 48 hours). Good roofing practice dictates proper drainage to prevent possible excessive live loads and, in the event of a roof leak, to minimize potential interior damage to the roofing assembly and to the interior of the building.
3. Tapered edge strips, crickets or saddles are recommended where periodic ponding of water may occur.

F. Vapor Retarder

1. Carlisle does not require a vapor retarder for the protection of the membrane; however, the following criteria should be considered by the specifier:
 - a. Use of a vapor retarder to protect insulation and reduce moisture accumulation within an insulated roofing assembly, should be investigated by the specifier. Consult latest publications by ASHRAE (American Society of Heating, Refrigerating and Air-Conditioning Engineers, Inc.) and NRCA (National Roofing Contractors Association) for specific information.
 - b. In the generally temperate climate of the United States, during the winter months, water vapor flows upward from a heated, more humid interior toward a colder, drier exterior. Vapor retarders are more commonly required in northern climates than in southern regions, where downward vapor pressure may be expected and the roofing membrane itself becomes the vapor retarder.
 - c. On cold storage/freezer facilities, the perimeter and penetration details must be selected to provide an air seal and prevent outside air from infiltrating and condensing within the roofing assembly

G. Wood Nailers

Wood nailers are required for the securement of metal edgings, metal scuppers, and certain curbs, pipes, etc., as shown on the applicable detail. Parapet walls and most curbs do not require the utilization of wood nailers.

A horizontal wood nailer is used to provide an effective substrate for some installation details and for other roof accessories. In addition, it is used to provide solid protection for the edge of the membrane underlayment. Minimum thickness of the nailer must be such that the top of the nailer is flush with the top of the membrane underlayment.

1. The width of the nailers must exceed the width of the metal flange of edgings, scuppers, etc.
2. When treated lumber is specified, it is recommended that only lumber that has been pressure treated with salt preservatives be specified. Lumber treated with any of the wood preservatives such as, Creosote, Pentachlorophenol, Copper Naphthenate and Copper 8-quinolinolate will adversely affect the FleeceBACK membrane when in direct contact and are, therefore, unacceptable.

If non-treated lumber is to be specified, it must be stored to protect from moisture sources. A seal should be provided between the non-treated lumber and a concrete or gypsum substrate (similar to a sill sealer).

3. Methods used to fasten the nailer vary with building conditions; however, it is essential that secure attachment of durable stock be accomplished. Factory Mutual Loss Prevention Data Bulletin 1-49

(Perimeter Flashing) contains options for the spacing and sizing of fasteners based on the project wind zone.

4. Wood nailers are not covered by the Carlisle warranty.

H. Retrofit – Recover Projects (when existing roofing material is left in place).

1. The removal of existing wet insulation and membrane must be specified. The specifier shall select an appropriate and compatible material as filler for voids created by removal of old insulation or membrane.

2. When specifying over existing PVC membranes, the membrane may be totally removed or be cut into maximum 10 foot by 10 foot sections. An acceptable membrane underlayment shall be specified and must be mechanically secured, refer to Warranty Table III in this specification. All PVC flashings at the perimeter, roof drains and roof penetrations must be removed.

3. When specifying this roofing system over existing gravel surfaced built-up roof, loose gravel must be removed to avoid entrapment of moisture. In all cases, a membrane underlayment is required.

4. Existing Phenolic Foam insulation must be removed prior to the installation of this roofing system.

1.08 Product Delivery, Storage, And Handling

A. Deliver materials to the job site in the original, unopened containers labeled with the manufacturer's name, brand name and installation instructions.

B. Prolonged exposure of Pressure-Sensitive Flashing and SecurTAPE to temperatures below 40°F (5°C) will cause the pre-applied adhesive to lose tack and in extreme cases, not bond to the membrane.

C. Job site storage temperatures in excess of 90°F (32°C) may affect shelf life of curable materials (i.e. sealants, cleaners, primers, SecurTAPE, Pourable Sealer, Pressure-Sensitive Flashing and uncured flashing).

D. When liquid adhesives and sealants are exposed to lower temperatures, restore to a minimum of 60°F (16°C) before use. Do not store containers with opened lids due to loss of solvent that will occur from flash-off.

E. Do not store adhesive, primer, Weathered Membrane Cleaner, etc., containers with opened lids due to the loss of solvent, which will occur from flash-off.

F. When loading materials onto the roof, the Carlisle Authorized Roofing Applicator must comply with the requirements of the specifier/owner to prevent overloading and possible disturbance to the building structure.

G. When temperature is expected to fall below 40°F (5°C), outside storage boxes should be provided on the roof for temporary storage of liquid adhesives and sealants. Adhesive and sealant containers should be rotated to maintain their temperature of above 40°F (5°C). Refer to Product Data Sheets for individual products for temperature restrictions.

H. FleeceBACK AFX Membrane should be stored in its original plastic wrap or be covered to protect from moisture. Any moisture absorbed by the fleece-backing must be removed by using a wet-vac system, prior to membrane mopping.

I. When specified, insulation must be stored so it is kept dry and is protected from the elements. Store insulation on a skid and completely cover with a breathable material such as tarp or canvas. If the insulation is lightweight, it should be weighted to prevent possible wind damage.

- J. When Flexible FAST Adhesive is specified for insulation attachment, refer to [Spec Supplement G-02-20 “Flexible FAST Adhesive Equipment and Set-Up Requirements”](#) for proper product delivery, storage and handling.

PART II PRODUCTS

2.01 General

The components of this roofing system are to be products of Carlisle or accepted by Carlisle as compatible. The installation, performance or integrity of products by others, when selected by the specifier and accepted as compatible by Carlisle is not the responsibility of Carlisle and is expressly disclaimed by the Carlisle Warranty. Other components (asphalt and pressure relief vents) which are not supplied by Carlisle, when required for the installation of this roofing system, may be included as part of the Carlisle Warranty.

2.02 Membranes

A. FleeceBACK AFX EPDM Membrane

The membrane incorporates 45-mil or 60-mil thick non-reinforced EPDM laminated to 7.5 ounce per square yard, non-woven polyester polypropylene blended fleece resulting in a total finished sheet thickness of 90-mil or 105-mil. Black membrane is available in 4.5' or 10' wide and lengths 50' or 100' with a nominal 3" or 6" wide Factory-Applied SecurTAPE. White membrane is available 4.5' wide and length 40' with a nominal 6" wide Factory-Applied SecurTAPE. SecurTAPE is provided on one edge along the length of the membrane for splicing. AFX membranes conform to ASTM Standard D 4637-95, Type III (Fabric-backed membrane) with the following physical properties:

| Physical Property | Test Method | SPEC.(Pass) | Sure-Seal | Sure-White |
|--|---|--|--|--|
| Tolerance on Nominal Thickness, % | ASTM D 751 | ±10 | ±10 | ±10 |
| Thickness over Fleece, min, in. (mm) 90 mil (2.286 mm) 105 mil (2.667 mm) | ASTM D4637 Annex | .030 (.762) .045 (1.14) | .045 (1.14) .060 (1.52) | - .060 (1.52) |
| Weight 1b/ft ² (kg/m ²) 90 mil (2.286 mm) 105 mil (2.667 mm) | - | - | 0.29 (1.42) 0.38 (1.86) | - 0.42 (2.1) |
| Breaking Strength, min, lbf (N) 90 &105-mil | ASTM D751 Grab Method | 90 (400) | 200 (890) | 200 (890) |
| Elongation, Ultimate, min, % | ASTM D 412 | 300 ** | 480 ** | 500** |
| Tearing Strength, min, lbf (N) 90 & 105-mil | ASTM D 751 B Tongue Tear | 10 (45) | 45 (200) | 45 (200) |
| Brittleness point, max, °F (°C) | ASTM D 2137 | -49 (-45) | -67 (-55) | -67 (-55) |
| Resistance to Heat Aging * Properties after 4 weeks @ 240°F (116°C) for Sure-Seal Breaking Strength, min, lbf (N) Elongation, Ultimate, min, % Linear Dimensional Change, max, % | ASTM D 573 ASTM D 751 ASTM D 412 ASTM D 1204 | 80 (355) 200 ** ±1.0 | 200 (890) 225 ** -0.7 | 200 (890) 225 ** -0.7 |
| Ozone Resistance * Condition after exposure to 100 ppm Ozone in air for 168 hours @ 104°F (40°C) Specimen wrapped around 3 inch (7.5 cm) mandrel | ASTM D 1149 | No Cracks | No Cracks | No Cracks |
| Resistance to Water Absorption * After 7 days immersion @ 158°F (70°C) Change in mass, max, % | ASTM D 471 | +8.0, -2.0 ** | 2.0 ** | 3.6 ** |
| Resistance to Outdoor (Ultraviolet) Weathering * Xenon-Arc, total radiant exposure at 0.70 W/m ² , 176°F (80°C) black panel temperature | ASTM G 155 | No Cracks No Cracking @ 7560 kJ/m ² | No Cracks No Cracking @ 41580 kJ/m ² (black) | No Cracks No Cracking @ 25200 kJ/m ² (white) |
| Puncture Resistance, Joules 90-mil 105-mil | ASTM D5635 | | 17.5 20 | - 25 |
| Puncture Resistance, lbf 90-mil 105-mil | FTM 101C Method 2031 | | 280 292 | - 280 |
| Puncture Resistance, lbf 90-mil 105-mil | ASTM D120 | | 21 22 | - 19 |
| * Not a Quality Control Test due to the time required for the test or the complexity of the test. However, all tests are run on a statistical basis to ensure overall long-term performance of the sheeting. | | | | |
| ** Specimens prepared from coating rubber compound. | | | | |

B. FleeceBACK AFX TPO Membrane

The membrane incorporates 45-mil, 60-mil or 80-mil thick Sure-Weld (white) reinforced TPO laminated to 10 ounce per square yard, non-woven polyester, polypropylene blended fleece resulting in a total finished sheet thickness of 120-mil, 135-mil, or 155-mil. A nominal 3" wide selvage edge is provided on one edge along the length of the membrane for hot air welding. Membranes are available in widths of 6' or 12' and a length of 75' and conform to the following physical properties:

| Physical Property | Test Method | SPEC. (Pass) | Sure-Weld |
|--|------------------------------|---|---|
| Tolerance on Nominal Thickness % | ASTM D 751 | +/-10 | +/-10 |
| Thickness of reinforced sheet over fleece min 120-mil (3.05mm) 135-mil (3.43mm) 155-mil (3.94mm) | ASTM D4637 Annex | .030 (.762) .045 (1.14) .080 (2.03) | .045 (1.14) .060 (1.52) .080 (2.03) |
| Weight lb/ft ² (kg/m ²) 120-mil (3.05mm) 135-mil (3.43mm) 155-mil (3.94mm) | | | .31 (1.51) .40 (1.95) .50 (2.44) |
| Breaking Strength, min, lbf (N) 120-mil (3.05mm) 135-mil (3.43mm) 155-mil (3.94mm) | ASTM D751 Grab Method | 90 (0.4) | 300 (1.3) 400 (1.8) 425 (1.9) |
| Elongation at break of internal fabric, % | ASTM D751 | | 25 |
| Puncture Resistance, Joules 120-mil 135-mil 155-mil | ASTM D5635 | | 17.5 22.5 30.0 |
| Puncture Resistance, lbf 120-mil 135-mil 155-mil | FTM 101C Method 2031 | 350 400 425 | 525 575 600 |
| Brittleness point, max, °F (°C) | ASTM D2137 | -40 (-40) | -50 (-46) |
| Linear Dimensional Change, % | ASTM D1204 | +/- 1 max | -0.2 typical |
| Field seam strength, lbf/in. (kN/m) 120-mil 135-mil 155-mil | ASTM D1876 Tested in peel | 25 (4.4) 25 (4.4) 40 (7.0) | 40 (7.4) 60 (10.5) 70 (12.3) |
| Water vapor permeance, Perms | ASTM E96 proc.B | | 0.10 max 0.05 typical |
| Resistance to microbial surface growth, rating (1 is very poor, 10 is no growth) | ASTM D3274 | | 9-10 typical |
| Properties after heat aging, 670 hrs @ 240°F Breaking Strength, % retained Elongation Reinf. % retained Tearing Strength, % retained Weight Change, % | ASTM D573 | | 90 min 90 min 60 min +/- 1.0 max |
| Ozone Resistance*, 100 pphm, 168 hours | ASTM D1149 | No Cracks | No Cracks |
| Resistance to Water Absorption * After 7 days immersion @ 158°F (70°C) Change in mass, max, % | ASTM D471 | +4 | +2 |
| Resistance to Outdoor (Ultraviolet) Weathering Xenon-Arc, total radiant exposure @ 0.70 W/m ² irradiance, 80°C black panel temp 120-mil (17,640 kJ/m ²), 135-mil (20,160 kJ/m ²), 155-mil (27,720 kJ/m ²) | ASTM G155 | No cracks or loss of breaking or tearing strength | No cracks or loss of breaking or tearing strength |
| * Not a Quality Control Test due to the time required for the test or the complexity of the test. However, all tests are run on a statistical basis to ensure overall long-term performance of the sheeting. | | | |

C. FleeceBACK KEE HP membrane

The membrane incorporates 50-, 60- or 80-mil thick Polyester Reinforced Elvaloy KEE HP PVC membrane laminated to a 55-mil non-woven fleece backing resulting in a total finished sheet thickness of 105-, 115, or 135- mils. Membrane sheets are available in rolls 10' wide by 100' long for 105- and 115-mil and 10' wide by 75' long for 135-mil. Sure-Flex FleeceBACK KEE HP Membrane is available in white, gray and tan and conforms to the following:

| Property | Test Method | FleeceBACK KEE HP PVC 105-mil | FleeceBACK KEE HP PVC 115-mil | FleeceBACK KEE HP PVC 135-mil |
|---|-------------|-------------------------------------|-------------------------------------|-------------------------------------|
| Thickness of reinforced sheet over fleece, in. (mm) | ASTM D 4434 | 0.050 min. (1.27) | 0.060 typ. (1.52) | 0.080 typ. (2.03) |
| Thickness over scrim, in. (mm) | ASTM D 4434 | 0.024 min. (0.61) | 0.029 typ. (0.74) | 0.036 typ. (0.91) |
| Breaking Strength (MD x CD), lbf (kN/m) | ASTM D 751 | 410 x 360 (72 x 63) | 450 x 410 (79 x 72) | 500 x 490 (87 x 86) |
| Elongation break of reinforcement (MD x CD), % | ASTM D 751 | 35 x 30 | 35 x 30 | 35 x 30 |
| Tearing Strength (MD x CD), lbf (N) | ASTM D 751 | 120 x 150 (534 x 222) | 120 x 150 (534 x 222) | 120 x 150 (534 x 222) |
| Low Temperature Bend | ASTM D 2135 | PASS (-40° C) | PASS (-40° C) | PASS (-40° C) |
| Linear Dimensional Change, % | ASTM D 1204 | 0.4 typ. | 0.4 typ. | 0.4 typ. |
| Water Absorption Resistance, mass % | ASTM D 570 | 1.25 | 0.87 | 0.89 |
| Puncture Resistance, Dynamic, J (ft-lbf) | ASTM D 5635 | PASS | PASS | PASS |
| Puncture Resistance, Static, lbf (N) | ASTM D 5602 | PASS | PASS | PASS |
| Xenon-Arc Resistance 12,600 kJ/m ² total radiant exposure 10,000 hrs | ASTM G 155 | PASS | PASS | PASS |
| Properties After Heat Aging, Breaking Strength, % retained | ASTM D 3045 | 90 min. | 90 min. | 90 min. |
| Properties After Heat Aging, Elongation Reinf., % retained | ASTM D 3045 | 90 min. | 90 min. | 90 min. |

2.03 Insulation / Underlayment

A. Product Information

1. Carlisle Polyisocyanurate

1. **Carlisle InsulBase Polyisocyanurate** – A foam core insulation board covered on both sides with a medium weight fiber-reinforced felt facer meeting ASTM C 1289-06, Type II, Class 1, Grade 2 (20 psi) or Grade 3 (25 psi). The product is available in 4' x 8' standard size with a thickness from 1 to 4 inches. 4' x 4' tapered panels are also available.
2. **Carlisle SecurShield Polyisocyanurate**– A foam core insulation board covered on both sides with a coated glass fiber mat facer meeting ASTM C 1289-06, Type II, Class 2, Grade 2 (20 psi) or Grade 3 (25 psi). The product is available in 4' x 8' standard size with a thickness from 1 to 4 inches. 4' x 4' tapered panels are also available. These flat board products feature a dark-colored coated-glass facer (CGF) on one side of the insulation board and a light-colored CGF on the other, labeled Ready Flash. Ready Flash Technology allows applicators to manage adhesive flash-off times by choosing between two different-colored facers on every board.
3. **Carlisle StormBase Polyiso Composite (OSB)** – HP-H Polyiso insulation bonded on the bottom side with a medium weight fiber-reinforced felt face and laminated with a top surface of 7/16" or 5/8" thick Oriented Strand Board (OSB) meeting ASTM C1289, Type V, Class1 Grade 2 (20 psi) or Grade 3 (25 psi). Available in 4' x 8' boards with thickness from 1-1/2" to 4".
4. **Carlisle SecurShield HD Composite Polyisocyanurate** – Composite insulation panel comprised of 1/2-inch high-density (109 psi max) Polyiso cover board laminated during the manufacturing process to SecurShield rigid Polyiso roof insulation meeting ASTM C1289 Type IV, Grade 2 (20 psi) or Grade 3 (25 psi). Available in 4' x 8' boards with thickness from 2" to 4.5". 4' x 4' panels are also available.

2. Carlisle Cover Boards

1. **Securock Cover Board** – A uniform composition of fiber-reinforced gypsum, without a facer, for use as a cover board or a thermal barrier. Available in 1/4" to 5/8" thick and 4' x 4' or 4' x 8' size boards. Long uninterrupted runs (>200') may require slight gapping due to thermal expansion.
2. **Sure-Seal HP Recovery Board** - A 1/2" or 1" thick high-density wood fiberboard with an asphalt coated facer for use as a cover board or recover board. Available 1/2" or 1" thick and 4' x 4' or 4' x 8' size boards.
3. **DensDeck Prime** –gypsum core that incorporates glass-mat facings on the top and bottom side. The top surface is pre-primed and provides excellent bond strength for adhered membrane for use as a cover board. Available in 1/4" to 5/8" and 4' x 4' or 4' x 8' size boards. Only for use with cold applied systems.
4. **DensDeck StormX Prime** – a reinforced gypsum cover board with an enhanced, moisture-resistant core and coated glass mat facers on the top and bottom side. The top surface is pre-primed and provides excellent bond strength for adhered membrane for use as a cover board. DensDeck StormX Prime is extremely durable and is approved for use in assemblies meeting FM's Very Severe Hail (VSH) Classification. Available in 5/8" thickness and 4' x 4' or 4' x 8' size boards.

3. Carlisle Base Sheets and Glass Ply Felts

| Insulations / Underlayment | Minimum Thickness | ASTM | Roofing System Acceptability | |
|---------------------------------|-------------------|-----------------------|------------------------------|--------------|
| | | | Hot Mopped | Cold Applied |
| Base Sheets | | | | |
| SureMB 120TG Base Ply | 120-mil | D6163 Type I, Grade S | √ | √ |
| SureMB 90 Base Ply | 90-mil | D6163 Type I, Grade S | √ | √ |
| SureMB 90TG Base | 94-mil | D6163 Type I, Grade S | √ | √ |
| SureMB 70 SA Base Ply | 70-mil | D6163 Type I, Grade S | √ | √ |
| SureMB Vented Base | - | D4897 Type II | √ | √ |
| SureMB G2 Base Sheet | - | D4061 Type II | √ | √ |
| FR Base Sheet 1S | - | D4869 Type I or II | √ | √ |
| Carlisle Type IV Glass Ply Felt | - | D2178 Type IV | √ | √ |
| Carlisle Type VI Glass Ply Felt | - | D2178 Type VI | √ | √ |

Notes: N/A = Not Acceptable √ = Acceptable

Base sheets may be installed directly under insulation or membrane and may be fastened with appropriate fasteners and plates over wood, fibrous cement, gypsum or lightweight insulated concrete. The base sheet may also be mopped directly to a primed concrete deck. Refer to Warranty Table II in this Specification for Warranty terms.

- a. **SureMB 120TG Base** – 120-mil smooth-surfaced, torch-grade SBS base ply, reinforced with a non-woven polyester mat that is saturated and coated with asphaltic bitumen and SBS elastomers that meets ASTM D6163 Type I, Grade S for SBS-modified bituminous sheet materials. Designed for use as a base-ply or inter-ply in Carlisle's multiple-ply system and may be used as an air barrier, vapor barrier or temporary (Up to 60 days) roof. Available in 39-3/8" wide and 32'-9" long (107 square feet) weighing 0.79 lbs per square foot.
- b. **SureMB 90 Base Ply** – 90-mil Glass fiber, reinforced, SBS-modified asphalt, base sheet that meets ASTM D 6163 Type I, Grade S for SBS-modified bituminous sheet materials. May be used

as an air barrier, vapor barrier and temporary (Up to 60 days) roof. Available in 39-3/8" wide and 49'-1" long (161 square feet) weighing 0.58 lbs per square foot.

- c. **SureMB 90TG Base** – 94-mil smooth-surfaced, SBS, torch-applied membrane. Reinforced with a fiberglass mat that is saturated and coated with asphaltic bitumen and SBS elastomers which meets ASTM D6163 Type I, Grade S. SureMB 90TG is designed for use as a base-ply or inter-ply in Carlisle's multiple-ply system and can be used as an air barrier, vapor barrier or temporary (Up to 60 days) roof. Available in rolls 39-3/8" wide and 49'-1" long (164 square feet) and weighing 0.57 lbs per square foot.
- d. **SureMB 70 SA Base Ply** – 70-mil smooth surface, self-adhered base ply. Reinforced with a fiberglass mat that is saturated and coated with asphaltic bitumen and SBS elastomer and meets ASTM D6163 Type 1, Grade S. 70 SA is designed to be used as a base ply or interplay in Carlisle's multiple-ply system and can be used as an air and vapor barrier or temporary (up to 60 days) roof.
- e. **SureMB Vented Base** – A heavyweight venting base sheet constructed from a fiberglass mat coated with weathering-grade asphalt which meets ASTM D4897 Type II and UL-G2. Typically used as a venting base sheet over lightweight insulating concrete or gypsum decks, used in conjunction with Carlisle Dual Prong Base Sheet Fastener. Available in rolls 39-3/8" wide and 33' long (100 square feet) and weighing 0.86 lbs per square foot.
- f. **SureMB G2 Base Sheet** - A non-porous 28 pound base sheet that meets ASTM D4601 Type II and UL-G2 which is mechanically fastened (using Carlisle approved fasteners) to the lightweight concrete, gypsum, or tectum substrate as the base ply with subsequent layers of SureMB G2 base sheet, Type IV, or Type VI Glass felt mopped to achieve a vapor/air retarder. Available in rolls 36" wide and 108' long (324 square feet) and weighing 0.11 lbs per square foot.
- g. **FR Base Sheet 1S** – A non-asphaltic fiberglass-based underlayment that meets ASTM D4869 Type I or II. In hot-mopped systems, FR Base Sheet can provide a suitable substrate for deck types requiring a fastened base. FR Base Sheet is also an ideal substrate for direct applications of hot-mopped systems or mechanically fastened (using Carlisle approved fasteners) systems over wood, tectum, gypsum and lightweight concrete decks. Available in rolls 48" wide and 250' long (1,000 square feet) weighing 0.09 lbs per square foot.
- h. **Carlisle Type IV Glass Ply Felt** - A heavyweight fiberglass mat containing heat-cured resinous binders saturated with type IV asphalt to meet ASTM D2178 Type IV and UL-G1, mopped over a nailed base sheet, a concrete deck, or an approved surface (minimum two plies) achieving a vapor/air retarder. When installed in a two-ply format, Type IV Glass Ply Felt may be used as a temporary (Up to 90 days) roof. Available in rolls 36" wide and 180' long (540 square feet) weighing 0.09 lbs per square foot.
- i. **Carlisle Type VI Glass Ply Felt** - A heavyweight fiberglass mat containing heat-cured resinous binders saturated with type IV asphalt to meet ASTM D2178 Type VI and UL-G2, mopped over a nailed base sheet, a concrete deck, or an approved surface (minimum two plies) achieving a vapor/air retarder. When installed in a two-ply format, Type VI Glass Ply Felt may be used as a temporary (Up to 90 days) roof. Available in rolls 36" wide and 180' long (540 square feet) weighing 0.10 lbs per square foot.

2.04 Related Materials

A. Hot Asphalt

Asphalt (ASTM D 312): Type III or IV Hot Asphalt is typically specified for this roofing system and shall conform to the physical properties listed below. As an option, Modified SBS or SEBS Asphalt may be used when conforming to the requirements as follows:

| Property/ASTM | Type III | Type IV | Modified Asphalt |
|---|---------------------------------|---------------------------------|------------------------------|
| Softening Point (° F) D-36 | Min. – 195 Max. – 205 | Min. – 210 Max. – 225 | Min. – 215 Max. – 235 |
| Flash Point (° F) D 92 | Min. – 525 Max. – 600 | Min. – 525 Max. – 600 | Min. – 525 Max. – 600 |
| Penetrations Units D 5 | @ 32 ° F = 6 @ 77° F = 16-24 | @ 32 ° F = 6 @ 77° F = 13-22 | @ 32 ° F = 7 @ 77° F = 18 |
| Ductility @ 77° F, cm D 113 | 3.0 | 2.0 | 7.0 |
| Solubility in Trichloroethylene % D 2042 | 99.8 | 99.8 | 97.5 |

B. Cut Back Asphalt Primer

CCW-550 Primer is a Cut Back Asphalt Primer that meets ASTM D 41 and is used to prime structural concrete decks, existing smooth BUR, mineral surfaced cap sheet, or modified bitumen membranes prior to mopping. Coverage rate is 1 to 2 gallons per 100 square feet depending on surface porosity.

CAUTION: Curing compounds used in conjunction with concrete decks must be confirmed by the concrete curing compound manufacturer as compatible with this attachment method. Certain curing compounds develop a wax-like seal or oil coating on the concrete’s surface that can prevent asphalt from adhering to the substrate.

C. Cold Applied Adhesive

Carlisle’s Cold Applied Adhesive is an asphalt-modified polyether VOC free adhesive. This product is a one sided, wet lay-in adhesive with FleeceBACK AFX and FleeceBACK KEE HP Membranes. Coverage rate is 1.5 gallons per square or 67 square feet (6.2 sq m) (26-mil) per gallon for smooth surfaces and 50 square feet (4.6 sq m) (32-mil) for uneven or semi-absorbent surfaces. Coverage rates are average and may vary due to conditions such as insulation type, surface, air temperature, and equipment (spreader), type of squeegee or paint roller.

D. Primers, Adhesives, Sealants, And Cleaners

Refer to Product Data Sheets for material coverage rates and proper usage. Prior to the use of any of the products listed below, consult the Material Safety Data Sheets for applicable cautions and warnings.

1. **Cut Back Asphalt Primer: CCW-550 Primer** is a Cut Back Asphalt Primer that meets ASTM D41 and is used to prime structural concrete decks, existing smooth BUR, mineral surfaced cap sheet, or modified bitumen membranes prior to mopping. Coverage rate is 1 to 2 gallons per 100 square feet depending on surface porosity.

CAUTION: Curing compounds used in conjunction with concrete decks must be confirmed by the concrete curing compound manufacturer as compatible with this attachment method. Certain curing compounds develop a wax-like seal or oil coating on the concrete’s surface that can prevent asphalt from adhering to the substrate.

2. **Cold Applied Adhesive:** Carlisle’s Cold Applied Adhesive is an asphalt-modified polyether VOC free adhesive. This product is a one sided, wet lay-in adhesive with FleeceBACK AFX and FleeceBACK KEE HP Membranes. Coverage rate is 1.5 gallons per square or 67 square feet (6.2 sq m) (26-mil) per gallon for smooth surfaces and 50 square feet (4.6 sq m) (32-mil) for uneven or semi-absorbent surfaces. Coverage rates are average and may vary due to conditions such as insulation type, surface, air temperature, and equipment (spreader), type of squeegee or paint roller.
3. **Carlisle Weathered Membrane Cleaner:** A clear, solvent-based cleaner used to loosen and remove dirt and other contaminants from the surface of exposed membrane for splicing procedures at an

approximate coverage rate of 400 square feet per gallon (one surface). Available in 1 and 5-gallon pails.

4. **Water Cut-Off Mastic:** A one-component, low viscosity, self-wetting, Butyl blend mastic used to prevent moisture migration at drains, compression terminations and beneath conventional metal edging at a coverage rate of approximately 10' per tube.
5. **Universal Single-Ply Sealant** A 100% solids, solvent free, VOC free, one part polyether sealant that provides a weather tight seal to a variety of building materials. It is white in color and is used for general caulking such as above termination bars and metal counter flashings and at scuppers.
6. **Low-VOC Bonding Adhesive** This product meets the <250 gpl VOC (volatile organic compound) content requirements of the OTC Model Rule for Single-Ply Roofing Adhesives. A high strength, solvent-based contact adhesive that allows bonding of membrane to various substrates. Available in 5 gallon pails.

Note: This product **does not comply** with Southern California counties with additional restrictions on solvents. See Carlisle's Product Data Sheet for a listing of the counties involved.

7. **Low-VOC Bonding Adhesive 1168:** This product meets the <250 gpl VOC (volatile organic compound) content requirements of the OTC Model Rule for Single Ply Roofing Adhesives. A high strength, solvent-based contact adhesive that allows bonding of membrane to various porous and non-porous substrates. Apply at a rate of 60 sq. ft. per gallon finished surface. Available in 5-gallon cans.

Note: This product **complies** with all counties in the State of California which have additional restrictions on solvents. See Carlisle's Product Data Sheet for a listing of the counties involved.

8. **Aqua Base 120 Bonding Adhesive:** A semi pressure-sensitive water based adhesive; used as a 2-sided contact adhesive for bonding Sure-Seal/Sure-White EPDM and Sure-Weld TPO membranes to various surfaces. Complies with the South Coast Air Quality Management District Rule 1168.

9. **Sure-Seal/Sure-White Products**

- a. **90-8-30A Bonding Adhesive:** A high-strength, yellow colored, synthetic rubber adhesive used for bonding EPDM membranes to various surfaces. Available in 5 gallon pails.
- b. **EPDM x-23 Low-VOC Bonding Adhesive:** A Low-VOC (volatile organic compound) bonding adhesive (less than 250 grams/liter) used for bonding Sure-Seal/Sure-White EPDM membranes to various surfaces. Adhesive is available in 5 gallon pails.
- c. **HP-250 EPDM Primer:** A solvent-based primer used to prepare the surface of EPDM membrane for application of Splice Tape, Pressure-Sensitive. Available in 1 gallon pails.
- d. **Low-VOC EPDM and TPO Primer -** A Low-VOC (volatile organic compound) primer (less than 250 grams/liter) for priming of EPDM or TPO surfaces prior to application of FAT, Cover strip, SecurTAPE and all other pressure-sensitive products. Available in 1 gallon pails.
- e. **Sure-Seal or Sure-White Pressure-Sensitive SecurTAPE:** A 3" or 6" wide by 100' long splice tape used for splicing adjoining sections of EPDM membrane. Complies with the South Coast Air Quality Management District Rule 1168.
- f. **Sure-Seal or Sure-White Lap Sealant:** A black, heavy-bodied material used to seal the exposed edges of a membrane splice. A pre-formed Lap Sealant tool is included in each carton of Lap Sealant. Available in tubes.
- g. **Pourable Sealer:** A black, two-component, solvent-free, polyurethane based product used for tie-ins and as a sealant around hard-to-flash membrane penetrating objects such as clusters of pipes and for a daily seal when the completion of flashings and terminations cannot be completed

by the end of each work day.

- h. **One-Part Pourable Sealer:** Available in black, a one-component, moisture curing, elastomeric polyether sealant used for attaching lightning rod bases and ground cable clips to the membrane surface and as a sealant around hard-to-flash penetrations such as clusters of pipes.

10. Sure-Weld Products

- a. **Sure-Weld Bonding Adhesive:** A high-strength, synthetic rubber adhesive used for bonding Sure-Weld membrane to various surfaces. The adhesive is applied to both the membrane and the substrate at a coverage rate of approximately 60 square feet per gallon per finished surface (includes coverage on both surfaces).
- b. **Cut-Edge Sealant:** A clear sealant used to seal cut edges of reinforced Sure-Weld membrane. A coverage rate of approximately 225 - 275 linear feet per squeeze bottle can be achieved when a 1/8" diameter bead is applied.
- c. **White One-Part Pourable Sealer:** A one-part, moisture curing, elastomeric polyether sealant used to fill TPO Molded Pourable Sealant Pockets. Packaged in 4, 2-liter foil pouches inside a reusable plastic bucket. 1 pouch will fill 2 TPO Molded Pourable Sealant Pockets.
- d. **TPO Primer:** A solvent-based primer used to prepare the surface of Sure-Weld Membrane prior to application of Pressure-Sensitive Cover strip and TPO Pressure-Sensitive RUSS.
- e. **TPO Low-VOC Primer:** A solvent-based, low solids primer used to prepare the surface of Sure-Weld Membrane prior to application of Pressure-Sensitive Cover strip and TPO Pressure-Sensitive RUSS.

11. Sure-Flex Products

- a. **Sure-Flex Low-VOC Bonding Adhesive:** A high-strength, synthetic rubber adhesive used for bonding Sure-Flex membrane to various surfaces. The adhesive is applied to both the membrane and the substrate at a coverage rate of approximately 60 square feet per gallon per finished surface (includes coverage on both surfaces).
- b. **Sure-Flex Cut-Edge Sealant:** A clear sealant used to seal cut edges of reinforced Sure-Flex membrane. A coverage rate of approximately 225 - 275 linear feet per squeeze bottle can be achieved when a 1/8" diameter bead is applied. The use of cut edge sealant to seal cut edges of Sure-Flex membrane is not required.
- c. **White One-Part Pourable Sealer:** A one-part, moisture curing, elastomeric polyether sealant used to fill Molded Sealant Pockets. Packaged in four 1/2 gallon pouches per plastic bucket. One pouch will fill 122 cubic inches of volume within a molded sealant pocket.
- d. **PVC and KEE HP Membrane Cleaner:** Used to prepare PVC and KEE HP PVC membrane that has been exposed to the elements for approximately 7 days prior to hot air welding or to remove general construction dirt. Approximate coverage rate of 400 square feet per gallon (one surface).
- e. **Sure-Flex Low-VOC PVC Step 1 Activator:** A high-strength, solvent-based activator that allows PVC Pressure-Sensitive (PS) Cover Strip to be bonded to Sure-Flex PVC or KEE HP membranes. Low-VOC PVC Step 1 Activator meets the < 250 gpl VOC content requirements of the OTC Model Rule. It is specially formulated using a blend of VOC-exempt and non-exempt solvents and follows the state of California Clean Air Act of 1988 (updated in 1997) as further regulated by California's Air Quality Control Districts listing VOC limitations.
- f. **Sure-Flex Low-VOC PVC Step 2 Primer:** A high-solids-content, polymer based splice primer. This product is applied to KEE HP and PVC membranes to improve the adhesion of PVC Pressure-Sensitive Cover Strip. Low-VOC PVC Step 2 Primer meets the < 250 gpl VOC content requirements

of the OTC Model Rule.

- g. **Sure-Flex PVC Step 2 Primer:** A high-solids-content, clear (translucent color), polymer-based splice primer used to prepare KEE HP and PVC membranes to be bonded to PVC Pressure-Sensitive Cover Strip.

2.05 Fastening Components

A. Fasteners

The following Table illustrates criteria for fastening of Carlisle Insulation with the referenced roof deck and includes minimum penetration requirements and pilot hole criteria.

Insulation/ Base Sheet Fastening Criteria

| Deck Type | Carlisle Fasteners (1) | Min. Penetration | Pilot Hole Depth | Pilot Hole Diameter |
|---|--|------------------|------------------|--------------------------|
| Steel or Lightweight Insulating Concrete over Steel | ASAP or InsulFast™ | 3/4" | N/A | N/A |
| Structural Concrete, rated 3,000 psi or greater | CD-10 | 1" | Note (2) | 7/32" |
| | HD 14-10 | 1" | Note (2) | 3/16" |
| Wood Plank, min. 15/32" thick Plywood or min. 7/16" OSB | HP, ASAP or InsulFast | Min. 1" (3) | N/A | N/A |
| Cementitious Wood Fiber | Polymer Gyptec or Dual Prong Fastener(6) | 1-1/2" | Note (4) | N/A |
| Gypsum | Polymer Gyptec or Dual Prong Fastener(6) | 1-1/2" | Note (2) | 7/16", 1/2" or 9/16" (5) |

Notes:

N/A = Not Applicable

(1) Only 3" diameter insulation fastening plates can be used for insulation attachment.

(2) The pilot hole must be predrilled to a sufficient depth to prevent contact between the fastener point and any accumulated dust in the predrilled hole. This will help prevent bottoming out of the fastener during installation.

(3) For wood planks only, fastener penetration shall not exceed 1-1/2".

(4) Most cementitious wood fiber decks do not require pre-drilling; however, Carlisle should be contacted prior to installation for verification of specific types that may require a pilot hole to be predrilled.

(5) Pilot hole size may be varied to maximize pullout resistance.

(6) For Base Sheet Attachment Only.

1. **Carlisle Dual-Prong Fastener** – A factory pre-assembled, 1.8" long fastener consisting of a precision tube formed from galvanized (G-90) coated steel, a 2.7" diameter disk formed from Galvalume (AX-55) coated steel and a locking staple of high tensile steel wire used to secure base sheets to cementitious wood fiber, lightweight concrete, and gypsum providing 70 lbs. of pullout resistance is achieved (40 lbs. Min.). **Used for Carlisle Base Sheet Securement when specified.**
2. **InsulFast Fastener:** A threaded Phillips drive fastener used with Carlisle insulation plates for insulation attachment to steel or wood decks. **Used for Carlisle Insulation attachment when specified.**
3. **HP Fastener:** A threaded E-coat square drive fastener. Used in conjunction with Carlisle 3" diameter Metal plate for insulation securement or 2" diameter Seam fastening plates for base securement at angle change.
4. **HP-X™ Fastener:** A heavy duty #15 threaded fastener with a #3 Phillips drive used with Carlisle's

Piranha™ Fastening Plate for membrane securement at angle change or in conjunction with Carlisle 3" diameter Metal plate for insulation securement.

5. **Pre-Assembled ASAP Fastener:** Carlisle's InsulFast Fastener pre-assembled with a 3" diameter plastic plate used **for insulation attachment only**. Installed using Olympic Fasteners' Fastening Tool.
6. **CD-10 Fastener:** A hammer-driven, non-threaded E-Coat fastener for use with structural concrete decks rated 3,000 psi or greater.
7. **HD 14-10 Concrete Fastener:** A #14 threaded fastener with a #3 Phillips drive used for minimum 3,000 psi concrete decks.
8. **Polymer Gyptec Fastener:** A glass-filled nylon auger fastener designed for securing insulation and/or membrane to specialty decks such as cementitious wood fiber or gypsum.
9. **Insulation Adhesive:** Refer to [Spec Supplement P-01-20 "Related Products"](#).
10. **HP Term Bar Nail-In:** A 1-1/4" long expansion anchor with threaded drive pin used for fastening Sure-Seal Termination Bar or Seam Fastening Plates to concrete, brick or block walls. The fastener is set by hammering the drive pin into place.

B. Fastening/Insulation Plates

1. **Insulation Fastening Plates:** A nominal 3" diameter metal plate used for insulation attachment in conjunction with the appropriate Carlisle Fastener.
2. **Seam Fastening Plates:** A 2" diameter metal plate used for membrane securement.
3. **Piranha Plate:** A 2-3/8" diameter metal barbed fastening plate used with Carlisle HP-X, CD-10 or HD 14-10 Fasteners for membrane or insulation securement.
4. **Gyptec Plates:** A 3" (26 gauge) steel plate for insulation and a 2" (22 gauge) steel plate for membrane attachment. The plates are stamped galvalume-coated steel.

2.06 Other Products

A. Flashing Accessories

1. Sure-Seal/Sure-White Products

- a. **Sure-Seal Pressure-Sensitive "T" Joint Covers:** A factory cut 6" x 6" or 12" x 12" uncured 60-mil thick EPDM flashing (with rounded corners) laminated to a nominal 30-mil Factory-Applied TAPE, used to overlay field splice intersections and to cover field splices at angle changes.
- b. **Sure-Seal/Sure-White Pressure-Sensitive Cured Cover Strip:** A 6" and 9" by 100' and 12" wide by 50' long Sure-Seal or Sure-White 60-mil cured EPDM membrane laminated to a nominal 30-mil cured Factory-Applied TAPE. The Cured Cover Strip is ideal for flashing gravel stops, metal edging, Carlisle Seam Fastening Plates and for EPDM repairs.
- c. **Sure-Seal Pressure-Sensitive Overlayment Strip:** A nominal 40-mil black, semi-cured EPDM membrane laminated to a nominal 30-mil cured, Factory-Applied TAPE. Available in 6" and 9" widths and 100' long rolls used to overlay seams, flash gravel stops, metal edgings and Seam Fastening Plates used for additional membrane securement.
- d. **Sure-Seal Pressure-Sensitive Elastoform® Flashing:** A 6" by 100', 9" or 12" wide by 50' long, 60-mil thick Sure-Seal uncured EPDM Flashing laminated to a 30-mil Pressure-Sensitive

TAPE used in conjunction with EPDM Primer.

Sure-Seal/Sure-White uncured Pressure-Sensitive Elastoform Flashing is used to flash inside and outside corners, pipes, scuppers and field fabricated pourable sealer pockets when the use of Carlisle pre-fabricated flashing accessories is not feasible.

- e. **Additional Accessories:** A complete line-up of Sure-Seal EPDM accessories including corners, curb wraps, pipe seals, and sealant pockets. For product information, refer to [Spec Supplement P-01-20 “Related Products”](#).

2. Sure-Weld Products

- a. **Sure-Weld Flashing:** Sure-Weld **non-reinforced flashing** is available in rolls 12" and 24" wide by 50' long. Flashing is used for inside/outside corners and field fabricated pipe flashings when the use of pre-molded or pre-fabricated accessories is not feasible. In addition, 45-mil by 6" wide by 100' long, 60-mil by 9" wide by 50' long and 80-mil by 9" wide by 50' long Sure-Weld reinforced membrane is available for overlaying fasteners and fastening plates.
- b. **Sure-Weld Pressure-Sensitive Cover Strip:** A nominal 40-mil thick non-reinforced TPO membrane laminated to nominal 35-mil thick cured synthetic rubber pressure-sensitive adhesive used in conjunction with TPO Primer or Low-VOC TPO Primer to strip in flat metal flanges (i.e., drip edges or rows of fasteners and plates). Available in rolls 6" wide by 100' long in colors of white, gray or tan. Not for use on 25—year or 30-year Warranty projects.
- c. **Sure-Weld TPO T-Joint Covers:** A 60-mil thick injection molded TPO flashing formed into a 4.5" diameter circle used to seal step-offs at splice intersections. Installation is mandatory on all 60, 72, and 80-mil TPO membrane systems and on 45-mil systems where step-offs have not been properly sealed. Packaged in boxes of 100.
- d. **Pre-Molded Accessories:** A complete line-up of pre-fabricated Sure-Weld TPO accessories including corners, curb wraps, pipe seals, sealant pockets, and walkway pads. For product information, refer to [Spec Supplement P-01-20 “Related Products”](#).

B. One-Way Relief Vents

Vents are required when the membrane is adhered over lightweight insulating concrete at the rate of 1 every 1,000 square feet for vermiculite and 2,000 square feet for cellular or perlite lightweight insulating concrete decks.

1. **Non-Weldable One-Way Pressure Relief Breather Vent:** 8" tall, spun aluminum vent with a base diameter of 11" and stack diameter of 5". Engineered to allow moisture and air to escape from within the roofing system. May be used in conjunction with Carlisle's ChannelDry EPS Insulation for a roof assembly over Lightweight Structural Concrete (See [Spec Supplement G-15-19](#)) or in conjunction with FleeceBACK AFX (EPDM and TPO) membranes over Lightweight Insulating Concrete (See [Spec Supplement G-04-20](#)).
2. **Weldable One-Way Pressure Relief Breather Vent:** 5.5" tall, stainless steel vent with a 60-mil weldable flange, a base diameter of 14" and stack diameter of 4". Engineered to allow moisture and air to escape from within the roofing system. May be used in conjunction with Carlisle's ChannelDry EPS Insulation for a roof assembly over Lightweight Structural Concrete (See [Spec Supplement G-15-19](#)) or in conjunction with FleeceBACK AFX (EPDM and TPO) membranes over Lightweight Insulating Concrete (See [Spec Supplement G-04-20](#)).

2.07 Roof Walkways

Walkways are to be specified at all traffic concentration points (i.e., roof hatches, access doors, rooftop ladders, etc.), and if regular maintenance (once a month or more) is necessary to service rooftop equipment.

1. Walkway types:

- a. **Sure-Seal/Sure-White Pressure-Sensitive Walkway Pads:** Sure-Seal (black) or Sure-White (white) molded walkway pads with Factory-Applied TAPE used to provide protection for areas of EPDM membrane that are exposed to regular rooftop maintenance.
- b. **Sure-Weld Heat Weldable Walkway Rolls:** Designed to protect Sure-Weld membrane in those areas exposed to repetitive foot traffic or other hazards. Walkway material may be heat welded to Sure-Weld membrane using an automated heat welder or hand held heat welder. The diamond plate tread pattern offers superior slip resistance. The walk edges are trimmed in safety yellow to better define the designated traffic flow. Walkway Rolls are 34" wide by 50' long and are nominal 180 mils thick. Available in white, tan or gray.
- c. **Carlisle Interlocking Rubber Pavers:** 24" X 24" X 2" thick rubber paver weighing approximately 24 pounds per unit, 6 pounds per square foot manufactured from recycled rubber, which provides a resilient, shock absorbing, weather resistant surface. Designed primarily for use as a walkway or on terrace areas offering a unique, environmentally sound advantage over concrete pavers. Features include freeze/thaw stability, bi-directional drainage and no breakage concerns. Available in black and terra cotta.
- d. **Hanover Pedestal Paver:** Used for light traffic areas associated with rooftop or garden roof applications. 23-1/2" x 23-1/2" x 2" thick precast concrete pavers weighing 25 psf with an elevated clearance of 1/2" from incorporated footing. Available in 8 standard colors, with special order colors available. The pedestal paver can either be installed in conjunction with a separation layer of HP Protective Mat or using Hanover Pedestal and shims.
- e. **Hanover Ballast and Lightweight Ballast Pavers:** The standard, 24" x 24" x 1-13/16" thick, Ballast Paver comes in a natural color and a non-slip Diamond finish and weighs 22 lbs/sq. ft. The Lightweight, 23-1/2" x 23-1/2" x 1-1/4" thick, Ballast Paver comes in a natural color and a non-slip diamond finish and weighs 15 lbs/sq. ft. Both pavers can be used as ballast or walkways

2.08 Edging And Terminations

- A. Refer to [Spec Supplement P-01-20 "Related Products"](#).

PART III EXECUTION

Prior to commencing with the installation of any of the Thermoplastic Membrane Systems refer to Paragraph 1.06 “Warranty Tables” for applicable components and proper securement method suitable for the appropriate warranty coverage.

Requirements listed in this specification are considered minimum and are intended for the sole purpose of obtaining a Carlisle Warranty. Additional requirements dictated by Regulatory Agencies, Building Insurance or Specifiers must be complied with and are considered to be beyond the scope of this specification.

3.01 General

- A. Safety Data Sheets (SDS) must be on location at all times during transportation, storage, and application of materials. The applicator shall follow all safety regulations as recommended by OSHA and other agencies having jurisdiction.
- B. Subject to project conditions, it is recommended to begin application of this roofing system at the highest point of project area and work to lowest point to prevent water infiltration. This will include completion of all flashings, terminations, and daily seals.
- C. Consult the Asphalt Manufacturer concerning asphalt heating temperature and minimum ambient temperature during installation.
- D. Do not apply Cold Applied Adhesive when ambient temperatures are below 40°F (5°C).
- E. Opened containers of Cold Applied Adhesive should be used within 2-3 weeks. The adhesive will form a thick surface skin that will not re-dissolve. Adhesive can be used once the skinned layer is removed.
- F. Asphalt or Cold Applied Application Rate Tables

Table I

| Asphalt/SEBS Application Rates | |
|---------------------------------------|-------------------------|
| AFX or KEE HP Membrane | 18-22 pounds per square |
| Base Sheet | 23-25 pounds per square |
| Insulation | 28-32 pounds per square |

Table II

| Cold Applied Adhesive Application Rates | |
|--|---|
| Smooth Surfaces | 1.5 gal per square or 67 square feet per gallon |
| Uneven or Semi-absorbent | 2.0 gal per square or 50 square feet per gallon |

Note: Coverage rates are average and may vary due to conditions such as insulation type, surface, air, and asphalt temperatures. Coverage rates may also vary based on the spreader and or type of squeegee or paint roller used for applications. When using a spreader with the Cold Applied Adhesive, it may be necessary to squeegee or back roll adhesive to obtain proper coverage

3.02 Roof Deck Criteria

A. General

1. Proper decking shall be provided by the building owner. The building owner or its designated representative must ensure that the building structure is investigated by a registered engineer to assure its ability to withstand the total weight of the specified roofing system as well as construction and live loads in accordance with all applicable codes. The specifier must also designate the maximum allowable weight and location for material loading and storage on the roof.
2. When mechanically fasteners are used to fasten the insulation, withdrawal resistance tests are strongly suggested to determine the suitability of a roof deck. Refer to [Design Reference DR-06-19 "Withdrawal Resistance Criteria"](#) in the Carlisle Technical Manual proper procedures for conducting pullout tests.
3. Defects in the roof deck must be reported and documented to the specifier, general contractor and building owner for assessment. The Carlisle Authorized Roofing Applicator shall not proceed unless the defects are corrected.

3.03 Substrate Preparation

A. General

1. For all projects (new or retrofit), the substrate must be relatively even without noticeable high spots or depressions. Accumulated water, ice or snow must be removed to prevent the absorption of moisture in the new roofing components and roofing system.
2. Prior to the placement of membrane underlayment, clear the substrate of debris and foreign material that may be harmful to the roofing system. Gaps greater than 1/4" must be filled with an appropriate material.
3. For direct application over an acceptable roof deck/substrate the substrate must be smooth, steel trowel finished (structural concrete), free of debris, protrusions, sharp edges and loose and foreign material. Cracks or voids in the substrate, greater than 1/4", must be filled with an appropriate material.
4. On retrofit - recover projects, cut and remove wet insulation, as identified by the specifier, and fill all voids with new insulation of type specified so it is relatively flush (+/-1/4") with the existing surface.
 - a. Entrapment of water between the old and new membrane can damage and deteriorate new insulation/underlayment between the two membranes. If a vapor retarder or air barrier is not specified, Carlisle recommends the existing membrane be perforated to avoid potential moisture accumulation and to allow the detection of moisture to enable the building owner to take corrective action.
 - b. For existing PVC membranes, if the membrane is not removed, it must be cut into maximum 10' by 10' sections. A new membrane underlayment must be mechanically fastened and all PVC flashings at the perimeter, roof drains and roof penetrations must be removed.
 - c. When installing this roofing system over existing gravel surfaced built-up roof, loose gravel must be removed. Power brooming is recommended by Carlisle to remove the loose gravel, which may trap moisture. Any uneven areas of the substrate must be leveled to prevent insulation from bridging.
 - d. On retrofit projects, all existing phenolic insulation must be removed.

B. Acceptable Decks/Substrates and Minimum Underlayment

| Construction Type | Acceptable Roof Deck/Substrate | Asphalt Applied | Cold Applied |
|----------------------------|--|------------------------------|--------------------|
| Retrofit/No Tearoff | Existing Smooth Surface BUR or Mineral Surface Cap Sheet | Direct Application | Direct Application |
| | Gravel Surfaced BUR | Cover Board / Insulation* | Insulation* |
| | Coal Tar Pitch | Cover Board / Insulation* | Insulation* |
| | Modified Bitumen | Direct Application | Direct Application |
| | Existing Single-Ply | Cover Board / Insulation* | Insulation* |
| Retrofit/Tearoff* | Existing roof material removed (regardless of deck type) | Contact Carlisle | |

* Refer to the Warranty Tables, Paragraph 1.06, of this specification, for the minimum underlayment requirements for a specific Warranty Coverage.

1. **Do not** adhere FleeceBACK AFX or FleeceBACK KEE HP Membranes directly onto low melting point asphalt. When the softening point of the asphalt falls below 185° F(85° C), the minimum membrane underlayment must be a fastened 1/2 inch thick HP Recovery Board, Securock, or an acceptable insulation.
2. For slopes less than 2 inches to one horizontal foot, the specifier must investigate the existing roofing material to ensure the asphalt has a minimum softening point of 185° F (85° C).
3. When a direct applied system is specified, the specifier should investigate previous repairs and contaminants to existing roofing material to determine if the softening point of the asphalt is below that mentioned above or other contaminants may contact the FleeceBACK AFX or FleeceBACK KEE HP Membranes. Temporary repairs completed with any contaminants (i.e., plastic roof cement) must be removed.
4. The substrate must be relatively smooth, dry and clear of debris, fins, loose edges, foreign materials, oils, grease, frost and fresh roof cement.
5. Prepare the existing material for mopping of FleeceBACK AFX or FleeceBACK KEE HP Membranes with CCW-550 Cut Back Asphalt Primer. For Cold Applied application, preparation by power-wash the existing roofing material.
6. On retrofit-recover projects, cut and remove wet insulation as identified by the specifier and fill all voids with new insulation, so that it is relatively flush.

C. New Construction When No Insulation Required

| Construction Type | Acceptable Roof Deck/Substrate* | Asphalt Applied | Cold Applied |
|-------------------------|---|--------------------|--------------------|
| New Construction | Structural Concrete (minimum 3000 psi) | Direct Application | Direct Application |
| | Plywood (minimum 15/32" thick) or Oriented Strand Board (minimum 7/16") | Base Sheet | Direct Application |
| | Wood Planks (minimum 3/4" thick) | Base Sheet | Direct Application |
| | Gypsum | Base Sheet | Direct Application |
| | Lightweight Insulating Concrete | Base Sheet | Direct Application |

* On Tearoff projects, conditions may vary depending on deck type and the existing roofing system being removed. In some cases, the new membrane assembly may be directly installed to the deck or in conjunction with a Carlisle Supplied base sheet. (Structural concrete, gypsum deck, fibrous cement, or lightweight insulating concrete.) When a complete Tearoff is specified, Carlisle may be contacted for a specific applicable requirement based on warranty duration.

D. Structural concrete deck

1. The substrate must be relatively smooth, dry and free of protrusions, debris, frost, sharp edges and loose / foreign materials. All gaps in the substrate greater than 1/4 inch must be filled with suitable material.
2. The membrane can be mopped directly to structural concrete which has been primed with CCW-550 Cut Back Asphalt primer prior to membrane mopping.

E. Projects with new lightweight insulating concrete

1. When no additional insulation is required, projects with new or existing lightweight insulating concrete substrates will require the use of a Carlisle supplied base sheet. Refer to Warranty Table II in this Specification for the appropriate base sheet to be utilized. Follow the fastening patterns in Figure 6.
2. Except when the lightweight insulating concrete is to be poured over slotted steel decks, pressure relief vents must be specified at a minimum rate of 1 every 2,000 square feet to relieve vapor pressure which may result from possible moisture entrapment beneath the lightweight insulating concrete between the time of concrete placement and membrane installation.
3. The surface of the lightweight insulating concrete must be smooth finished, free of protrusions, sharp edges, frost, and loose / foreign materials.
4. The direct application of this roofing system is not permitted when a lightweight insulating concrete (regardless of type) is specified over an existing roofing material.

3.04 Wood Nailer Installation

A. General

1. Methods used to fasten the nailer vary with building conditions; however, it is essential that secure attachment of durable stock be accomplished. Factory Mutual Global Property Loss Prevention Data Sheet 1-49 (Perimeter Flashing) contains options for the spacing and sizing of fasteners.
2. The wood nailer must be installed so the top of the wood nailer is relatively flush (+/- 1/4") with the top surface of the insulation/underlayment and the width of the wood nailer exceeds the width of the metal flange (edgings, scuppers, insulated collars, etc.) as shown on the appropriate Carlisle detail.
3. Install wood nailers in those locations that have been designated by the specifier and as approved by Carlisle.
4. Follow the specifier's guidelines for securement of wood nailers.
5. Avoid fastening into existing deteriorated or dry rotted wood nailers
6. Refer to [Design Reference DR-08-11 "Wood Nailers and Securement Criteria"](#).

3.05 Base Sheet And Insulation Attachment

A. General

1. Do not install more insulation/underlayment that can be covered by membrane and made watertight in the same day.
2. All insulation boards must be butted together with no gaps greater than 1/4 inch. Gaps greater than 1/4 inch must be filled with same material.
3. Multiple layers of insulation are recommended, with all joints staggered between layers.
4. When the FleeceBACK AFX or FleeceBACK KEE HP Membranes is to be installed in conjunction with Carlisle Modified Base Sheet over roof insulation, 1/2 inch HP Recovery Board or 1/2 inch Securock is required as an underlayment. The underlayment may be mopped when used in conjunction with Polyisocyanurate Insulation or mechanically fastened when used with Polystyrene Insulation, see Section 2.03 of this Specification for further information.

B. Base Sheet Attachment

1. For Concrete Decks

- a) When base sheets are to be mopped to a structural concrete deck, the deck must be primed with CCW-550 Cut Back Asphalt Primer (ASTM D 41) prior to mopping base sheets. Depending on surface porosity, CCW-550 Cut Back Asphalt must be applied at a rate between of 1 to 2 gallons per 100 square feet.
- b) When specified, each layer of base sheet shall be hot mopped at the rate listed in Asphalt Application Rate Table I in Paragraph 3.01.

2. For Gypsum, Lightweight Insulated Concrete, and Fibrous Cement Decks

- a) Prior to installing either the FleeceBACK AFX or FleeceBACK KEE HP Membranes or insulation in asphalt, Carlisle Base Sheets shall be fastened into the gypsum, lightweight insulated concrete, or fibrous cement with Carlisle Dual Prong fasteners as shown.

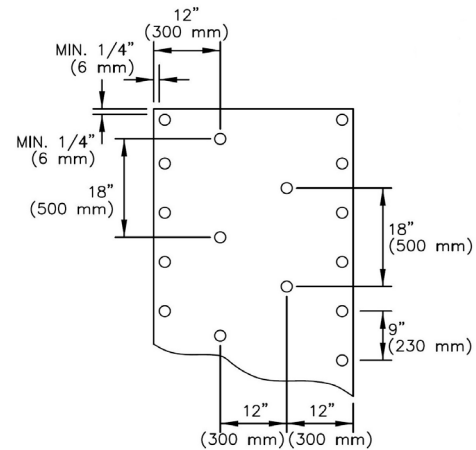

Figure 6

3. Wood Decks (Wood Plank or Min. 15/32" thick Plywood ONLY)

- a) When no insulation is specified and FleeceBACK AFX or FleeceBACK KEE HP Membranes is to be directly mopped to a Carlisle Modified Base Sheet. The base sheet must be fastened with Carlisle HP or HP-X Fasteners with 3" diameter insulation plates are used to attach the Carlisle Modified Base Sheet in rows 18" apart, 12" on center, refer to the fastening pattern in figure 7.

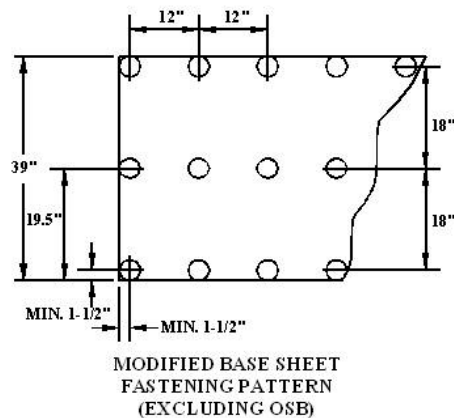

Figure 7

C. Insulation Attachment

The approved Carlisle Insulation may be adhered with asphalt, adhered with FAST Adhesive, or mechanically attached, as outlined in Warranty Table III of this Specification.

1. When roof insulation is to be adhered individual board sizes shall be limited to 4' by 4' to ensure full

embedment. Board size may be extended to 4' by 8' when mechanically securement is specified. Use appropriate Carlisle fasteners for deck type and ensure minimum deck penetration as outlined in [Design Reference DR-06-19 "Withdrawal Resistance Criteria"](#).

2. When insulation is to be mopped to a structural concrete deck, the deck must be primed with CCW-550 Cut Back Asphalt Primer (ASTM D 41) prior to mopping insulation to the deck. Depending on surface porosity, cut back asphalt must be applied at a rate between of 1 to 2 gallons per 100 square feet.
3. When specified, the insulation may be adhered with asphalt to a Carlisle Base Sheet or a primed concrete deck with Type III or IV Asphalt, or SEBS at the rate listed in Asphalt Application Rate Table I in Paragraph 3.01.

3.06 FleeceBACK AFX or FleeceBACK KEE HP Membranes Installation

A. General

1. Membrane shall be stored in a dry area to prevent absorption of moisture in the fleece backing. If moisture is present, it must be removed with a wet vac system and the membrane must be allowed to fully dry prior to membrane adhesion.
2. Position membrane over the acceptable substrate without stretching and overlap adjoining sheets.
3. When overlapping adjoining FleeceBACK AFX or FleeceBACK KEE HP Membranes, extend fleece backing approximately ½ inch above previously installed membrane. This will avoid direct contact between membrane in the seam area and hot asphalt or Cold Applied Adhesive.
4. Allow membrane to relax approximately 1/2 hour before Asphalt or Cold Adhesive Application.

Note: Due to stiffness of the Sure-Weld membrane, temporarily weigh down the ends of the membrane rolls to control re-curling of membrane until membrane lays flat.

B. FleeceBACK AFX or FleeceBACK KEE HP Membranes Adhered with Asphalt

1. General
 - a. The temperature of the asphalt during application shall be within 25° F (-4° C) from the EVT (Equiviscous Temperature). The manufacturer's heating instructions (i.e., maximum heating temperature, prolonged storage temperature guidelines) must be strictly followed.
 - b. When adhering the FleeceBACK AFX or FleeceBACK KEE HP Membranes with asphalt, refer to Asphalt Application Rate Table I in Paragraph 3.01, for coverage rates. It is important that "heavy spots" of asphalt, typically occurring at mopping overlaps or where the mop is first positioned, be avoided. At these areas, the asphalt must be spread evenly to avoid a heavy coverage rate that can cause asphalt saturation of the fleece backing. Asphalt saturation of the fleece must be avoided.
 - c. Adhering the FleeceBACK AFX or FleeceBACK KEE HP Membranes with asphalt directly to Polyisocyanurate insulation is not permitted. Carlisle HP Recovery Board or Securock must be used as an overlayment when insulation is specified.
2. Hand Mopping Method
 - a. When using a hand mop to apply asphalt, position the membrane over the substrate overlapping adjacent sheets to accommodate membrane splicing and fold in half lengthwise to expose the substrate and the back side of the membrane (full width of the membrane by approximately half the length).

- b. Beginning at the membrane fold, apply asphalt to the substrate the full width of the membrane extending a maximum of 3 to 6 feet while rolling the membrane into the asphalt immediately. The asphalt temperature at the time of membrane adhesion must be above 325° F (163° C). Continue to apply asphalt for the full width of the membrane extending 3 to 6 feet at a time while embedding the membrane into the asphalt until the entire half of the sheet is adhered. Fold back the unbonded half of the membrane and repeat the bonding procedures identified above.
3. Asphalt Spreader Method
 - a. When using spreaders to apply asphalt, the membrane is folded widthwise dependent on the size of the spreader (36" – 57" wide); i.e., if a 36" wide spreader is used, the membrane will be folded to expose approximately a 36" wide by 50' long area. After the asphalt is applied in a single pass, the membrane is rolled into the asphalt. After adhering the first half of the membrane, apply asphalt to the remaining substrate area in single passes and continue to bond membrane as identified above.
 - b. Care must be taken to ensure the proper coverage rate is maintained. Do not overlap asphalt layers at multiple pass lines since the heavy coverage rate occurring at these overlapping areas must be avoided.
 - c. Membrane must be embedded into asphalt immediately after each spreader pass to ensure asphalt temperature is at least 325° F (163° C) at the time of membrane embedment.
 - d. Monitor that the asphalt is not dropped directly on the back of the membrane. Use a mop to spread asphalt at pass lines and under sheet folds to prevent a heavy coverage rate.
 4. As the applicator installs the membrane by either method, the applicator should test embedment of membrane into the asphalt. After approximately 30 feet of membrane installed, the applicator should pull back the edge of the membrane and observe asphalt coating the white fleece in a uniform manner. If discovered that this is not occurring, the applicator should review temperature and heating process of the asphalt.
 5. After membrane applying the Cold Applied Adhesive, immediately after adhesion, brush down the sheet with a stiff bristled broom using light to medium pressure.
CAUTION: Do not use weighted rollers or heavy pressure when brooming the membrane to avoid asphalt saturation of the fleece.

Note: Foot traffic should be avoided until the asphalt has cooled sufficiently.

C. FleeceBACK AFX or FleeceBACK KEE HP Membranes Adhered with Cold Applied

1. Fold the membrane widthwise and apply the adhesive to the substrate.
2. Apply Carlisle Cold Applied adhesive to the substrate in a bead or serpentine pattern avoiding globs, puddles and uncoated areas. Use a flat blade squeegee, paint roller, or an acceptable spreader to spread adhesive at the coverage rates specified in the Cold Adhesive Application Rate Table II in Paragraph 3.01.
3. Broom the sheet using a stiff bristled broom applying light to medium pressure. The use of a 75lb weighted roller is optional. To avoid over-saturation of the AFX fleece do not roll more than once or twice and if temperatures exceed 75° F (74° C), rolling is not allowed. All adhesive residues in the splice area must be removed before splicing.
4. Fold back the unbounded half of the membrane sheet and repeat the bonding procedure.
5. Install adjoining membrane sheets in the same manner, overlapping edges to provide for the minimum splice width. Good roofing practice recommends all splices to be shingled to avoid bucking of water.

3.07 FleeceBACK AFX EPDM Membrane Splicing With Factory-Applied SecurTAPE

A. General

1. FleeceBACK AFX EPDM membrane has a selvage edge (fleece backing is discontinued) along the length of the sheet for membrane splicing.
2. If membrane becomes contaminated with field dirt, etc., remove dirt or excess dust from mating surfaces of overlapping sheets by wiping with Sure-Seal HP Splice Wipes or clean natural fiber rags. Accumulated dirt, footprints, etc. must be removed by scrubbing membrane with Weathered Membrane Cleaner or an EPDM primer.
3. **Projects with 10, 15 and 20 year Warranties - [Detail AFX-2A](#)**

Side Laps: Tape splices must be a minimum of 2-1/2" wide using **3" wide field-applied Pressure Sensitive SecurTAPE OR 3" Factory-Applied TAPE (FAT)**. ([Detail AFX-2A](#)).

End Laps: A minimum of 6" wide Pressure-Sensitive Cured Cover strip or Pressure-Sensitive Overlayment Strip shall be used at all end laps and shall be centered over the leading edge (butt edge) of the splice. ([Detail AFX-2A](#)).

Splice Intersections: All intersections between the Pressure-Sensitive Cover strip and side laps shall be overlaid by a 6"x6" minimum (black) or 7"x9" (white) Pressure-Sensitive 'T'-Joint cover with a bead of Lap Sealant. ([Detail AFX-2A](#)).

Note: In lieu of the 7"x9" Sure-White Pressure Sensitive 'T'-Joint cover, a 6"x6" section of white Pressure-Sensitive Elastoform flashing may be used. White Pressure-Sensitive Elastoform flashing is available in rolls of 6", 9" and 12".

4. Projects with 25 and 30 year Warranties - [Detail AFX-2A.1](#)

Side Laps: Must be a minimum of 5-1/2" wide using 6" wide Field-Applied or Factory-Applied Tape (FAT) OR if 3" wide Factory-Applied Tape (FAT) SecurTAPE is used, the 3" Tape must be overlaid with 6" Pressure-Sensitive Cured Cover Strip. ([Detail AFX-2A.1](#)).

End Laps: Use two layers of Pressure-Sensitive Flashing as an overlay for the end laps. The first layer shall be 6" wide Pressure-Sensitive Overlayment Strip or Pressure-Sensitive Cured Cover Strip and the top layer shall be 12" wide Pressure-Sensitive Elastoform Flashing. Both layers shall be centered over the butt edges of the sheet.

Splice Intersections: 'T'-Joints are to be flashed with a bead of lap sealant and 6"x6" (black) or 7"x9" (white) Pressure-Sensitive 'T'-Joint Cover. Apply a second layer of 12"x12" Pressure-Sensitive 'T'-Joint Cover centered over 6" x 6" 'T'-Joint Cover. ([Detail AFX-2A.1](#)).

Note: In lieu of the 7"x9" Sure-White Pressure-Sensitive 'T'-Joint cover, a 6"x6" section of white Pressure-Sensitive uncured Elastoform flashing may be used. White Pressure-Sensitive Elastoform flashing is available in rolls of 6", 9" and 12".

5. For splicing procedures refer to [Spec Supplement E-02-18 "EPDM Membrane Splicing and Splice Repairs"](#).

3.08 FleeceBACK AFX TPO or FleeceBACK KEE HP Heat Welding Procedure

A. General

1. Heat weld the FleeceBACK AFX TPO or FleeceBACK KEE HP membrane sheets using the Automatic Heat Welder or Hot Air Hand Welder and silicone roller.

2. When roof slope exceeds 5" per horizontal foot, use of the Automatic Heat Welding Machine may become more difficult; use of the Hand Held Hot Air Welder is recommended.
3. Check the surfaces of the membrane to be heat welded to ensure they are properly prepared.

The surfaces to be heat welded must be clean. Membrane overlaps that become contaminated with field dirt must be cleaned with Weathered Membrane Cleaner. Weathered Membrane Cleaner should be wiped dry with a clean HP Splice Wipe prior to welding. No residual dirt or contaminants should be evident.

B. Automatic and/or Hand Held Heat Welder Equipment

1. Refer to [Spec Supplement T-01-18 "Heat Welding Equipment"](#) for:
 - a. Temperature Settings.
 - b. Equipment Set-up.
 - c. Additional Information.

C. Membrane Welding

1. Prepare the Automatic Heat Welder and allow it to warm for approximately 5 to 10 minutes to reach operating temperature.
2. Position the Automatic Heat Welder properly prior to seaming with the guide handle pointing in the same direction the machine will move along the seam.
3. Lift the overlapping membrane sheet and insert the blower nozzle of the Automatic Heat Welder between the overlap. Immediately begin moving the machine along the seam to prevent burning the membrane.
4. Weight plates provided on Automatic Welders must be utilized.
5. Proceed along the seam ensuring that the small guide wheel in front of the machine aligns with the edge of the top membrane sheet. Guide the machine from the front only.

CAUTION: Ensure the power cord has plenty of slack to prevent dragging the machine off course (which could result from a tightly stretched cord).

6. At all splice intersections, roll the seam with a silicone roller to ensure a continuous heat welded seam (the membrane should be creased into any membrane step-off with the edge of the silicone roller). A false weld may result due to surface irregularities created by multiple thicknesses of FleeceBACK AFX TPO membrane sheets.

Note: When using 135-mil or 155-mil Sure-Weld Membrane, a TPO "T" Joint Cover must be applied over all "T" joint splice intersections. When FleeceBACK KEE HP 115- or 135-mil membranes, a surface splice of non-reinforced flashing or "T-Joint" Cover must be applied over all "T-Joint" splice intersections.

7. To remove the Automatic Heat Welder from the finished splice, stop the movement of the machine and immediately remove the nozzle from the seam area.
8. Mark the end of the heat welded seam with a water-soluble marker for easy identification. A Hand Held Welder will be necessary to complete the weld in the area between where the Automatic Heat Welder is stopped and restarted.

D. Preventing Membrane Creeping During Welding

The operator of automatic welding equipment must apply foot pressure to the membrane, keeping the membrane tight under the welder. Refer to [Spec Supplement T-01-18 "Heat Welding Equipment"](#) for

additional information.

E. Test Cuts

Perform a test weld at least at the start of work each morning and afternoon. Refer to [Spec Supplement T-01-18 “Heat Welding Equipment”](#) for additional information.

F. Seam Probing

A blunt or dull cotter pin puller is recommended to probe all heat-welded seams. Probing seams must be done once heat welds have thoroughly cooled. Refer to [Spec Supplement T-01-18 “Heat Welding Equipment”](#) for additional information.

G. Seam Sealing

Apply Cut-edge Sealant on all cut edges of the reinforced membrane (where the scrim reinforcement is exposed) after seam probing is completed. Cut-Edge Sealant is not required on vertical splices. When a 1/8" diameter bead of Cut-Edge Sealant is applied, approximately 225 – 275 linear feet of coverage per squeeze bottle can be achieved.

3.09 Welding Problems/Repairs

- A. A Hand Held Hot Air Welder and a 2" wide silicone roller must be used when repairing the FleeceBACK AFX TPO membrane. When the entire heat welded seam is to be overlaid, an Automatic Heat Welder may be used.
- B. Prior to proceeding with any repair procedure, the area to be repaired must be cleaned with Weathered Membrane Cleaner. The membrane can typically be repaired with standard cleaning methods. In cases where the standard cleaning method is not sufficient, the following procedures must be used.
 - 1. Scrub the area to be welded with a “Scotch Brite” Pad and Weathered Membrane Cleaner.
 - 2. Clean all residue from the area to be welded with a Splice Wipe or a clean natural fiber (cotton) rag.
 - 3. Weld the new membrane to the cleaned area using standard welding procedures.
- C. Voids in welded seams can be repaired using a Hand Held Hot Air Welder and a silicone roller. Depending on conditions, a splice overlay may be required.
- D. Position the Hand Held welder facing into void so hot air is forced between overlapping membranes. Roll the top membrane surface using positive pressure toward the outer edge until the heated membrane surfaces are fused.
- E. Exposed scrim-reinforcement (resulting from scorching surface of membrane) and test weld areas must be repaired by overlaying the damaged area with a separate piece of Sure-Weld reinforced membrane with rounded corners. The overlay must extend a minimum of 2 inches past the area to be repaired.
- F. Probe all edges of the overlay once cooled to ensure a proper weld has been achieved.

Note: The same overlay repair procedures may be used for punctures in the FleeceBACK AFX TPO membrane.

3.10 Additional Membrane Securement For FleeceBACK AFX or FleeceBACK KEE HP Membrane Adhered With Cold Applied Adhesive

Caution: Regardless of membrane type, FleeceBACK AFX (EPDM or TPO) or FleeceBACK KEE HP Membrane, when cold applied adhesive is used, securement must be provided at the perimeter of each roof

level, roof section, expansion joint, curb flashing, skylight, interior wall, penthouse, etc., at any inside angle change where slope exceeds 2" in one horizontal foot, and at other penetrations in accordance with Carlisle's published details.

- A. Approved Seam Fastening Plates may be installed horizontally into the structural deck or vertically into walls or curbs. Refer to Fastening Components Section 2.05 of this Specification for product information.
- B. Securement of the FleeceBACK AFX or FleeceBACK KEE HP Membrane with the approved Carlisle Fasteners and Seam Fastening Plates must be a maximum of 12" on center starting 6" minimum to 9" maximum from inside and outside corners.
- C. If horizontal wood nailers are provided, along parapet walls/curbs, secure the membrane with Seam Fastening Plates to the wood nailer with Carlisle HP Fasteners. Roofing nails are not acceptable for securement.
- D. After securing the Seam Fastening Plates, flash in accordance with the appropriate detail.

3.11 Flashing Considerations

In addition to listed below, [Spec Supplement G-05-20 "Flashing Considerations / Metal Work"](#) must be referenced for other requirements.

- A. General Flashing Considerations
 - 1. At roof drains and compression seal terminations such as terminations bars and coping stones, the fleece-backing must be removed from the back of the membrane so Water Cut-Off Mastic can be applied directly to the membrane surface.
 - 2. Cut edges of FleeceBACK AFX TPO membrane or Sure-Weld reinforced membrane (when used for flashing), where scrim reinforcement is exposed, must be sealed with Cut-Edge Sealant (not required on vertical surfaces). The use of PVC Cut-Edge Sealant on cut edges of FleeceBACK KEE HP membrane is not required.
 - 3. Care must be taken when setting the flashing to avoid bridging greater than 3/4" at angle changes (i.e., where a parapet or roof penetration meets the roof deck). This can be accomplished by applying heat to the membrane and creasing the membrane into the angle change.
 - 4. For the FleeceBACK AFX EPDM Membrane, all vertical field splices must be overlaid at the base of a wall or curb. Use a 6" x 6" section (with rounded corners) of Sure-Seal Pressure-Sensitive Overlayment Strip centered over the field splice.
 - 5. Sure-Seal Pressure-Sensitive Uncured Flashing must be limited to overlayment of vertical seams (as required at angle changes), or to flash inside/outside corners, vent pipes, scuppers and other unusually shaped penetrations where the use of pre-molded pipe seals, membrane, Pressure-Sensitive Overlayment Strip (semi-cured), or Cured Cover Strip is not practical.
 - 6. Adhering FleeceBACK AFX or FleeceBACK KEE HP membrane to a wall surface with asphalt, the continuous deck membrane may be used as flashing. Care must be taken and any large drips and pools of asphalt accumulated at the base of the wall must be removed. Flashing height is limited to a maximum of 18".
 - 7. FleeceBACK AFX or FleeceBACK KEE HP membrane adhered to the wall with appropriate bonding adhesive. When applying bonding adhesive to the fleece backed membrane, apply a coat to the fleece side of the membrane and allow to completely dry. Once dry, apply bonding adhesive to the wall substrate and the back of the membrane previously coated with bonding adhesive at a coverage rate of 60 square feet per gallon (finished surface).

8. For additional flashing considerations, refer to [Spec Supplement G-05-20 “Flashing Considerations / Metal Work”](#).
9. **Flashing of Difficult Penetrations**, refer to [Spec Supplement G-13-20 for “LIQUISEAL Liquid Flashing”](#) for additional information and specific requirements.

3.12 Related Products Installation

A. Metal Work

Factory-fabricated metal edge systems must be secured to the wood nailer as specified by the manufacturer. Shop-fabricated edging and Carlisle TPO Coated Metal must be installed in compliance with appropriate Carlisle Detail in order to achieve ES-1 Compliance. Refer to the appropriate Universal Details, [Spec Supplement G-05-20 “Flashing Considerations / Metal Work”](#), and [Design Reference DR-12-17 “Metal Edging”](#) for flashing considerations.

B. Roof Walkways

Walkways are to be specified at all traffic concentration points (i.e., roof hatches, access doors, rooftop ladders, etc.), and if regular maintenance (once a month or more) is necessary to service rooftop equipment. Refer to [Spec Supplement G-06-19 “Roof Walkway Installations”](#).

C. Daily Seal/Clean Up Procedures

On phased roofing, when the completion of flashings and terminations is not possible by the end of each workday, provisions must be taken to temporarily close the membrane to prevent water infiltration. For additional information refer to [Spec Supplement G-07-20 “Daily Seal / Clean Up”](#).

Attach copies of the applicable Carlisle Details that pertain to the individual project to complete a bid package submittal.

Copyright 2024 Carlisle Construction Materials Incorporated
Carlisle, Elastoform Flashing, FAST, FAST Adhesive, FAT and Factory Applied Tape, FleeceBACK, HPX Fasteners, InsulBase, InsulFast, Piranha Plate, Pre-Kleened, SAT/Self Adhering Technology, SecurEdge, Securfast, SecurShield, SecurTAPE, StormBase, Sure-Flex, Sure-Seal, Sure-Tough, Sure-Weld, Sure-White, VapAir Seal and X-Tenda Coat are Trademarks of Carlisle Construction Materials Incorporated

DensDeck, DensDeck Prime and DensDeck StormX Prime are Trademarks of Georgia-Pacific Corporation
Securock is a Trademark of USG

This specification represents the applicable information available at the time of its publication. Owners, specifiers and Carlisle Authorized Roofing Applicators should consult Carlisle or their Carlisle Manufacturer's Representative for any information, which has subsequently been made available.

Review the appropriate Carlisle warranty for specific warranty coverage, terms, conditions and limitations.



“Attachment I” Mechanically Fastened Option For Recover Application

January 2024

A. Description

The Mechanically Fastened membrane option is available when using either AFX EPDM or AFX TPO membrane. In lieu of adhering the AFX Membrane to an approved substrate with asphalt or cold applied adhesive, the AFX Membrane may be mechanically fastened along the side laps over an approved substrate to an acceptable deck using the appropriate Carlisle Fasteners and seam plates.

B. Approved Substrates

Existing Type III or IV smooth built-up roofing, mineral surfaced cap sheets, or modified bitumen. Substrate must be dry and free of debris or other contaminants. For other substrates, Carlisle may be contacted for recommendations and specific substrate preparations and requirements

C. Warranty Criteria for 55-mph 15-year Membrane System Warranty

Projects requiring extended wind speed coverage or a 20-year System Warranty must be submitted to Carlisle for review prior to installation

1. Membrane sheet width, fastener types, and fastening density

| Membrane Type | Field Sheet Width | Perimeter Sheet Width | Fastener / Seam Plate | Fastening Density in the Seams |
|---------------|-------------------|-----------------------|-------------------------------|--------------------------------|
| AFX EPDM | 10-ft | 4.5-ft | HP Fastener / Polymer Plate | 12" o.c. |
| AFX TPO | 12-ft | 6-ft | HP-X Fastener / Piranha Plate | 12" o.c. |

2. Number of Perimeter Sheets

| ASCE 7 Wind Zone | Acceptable Deck Type** | # Perimeter Sheets* |
|---|---|---------------------|
| 100 mph or less | 22-ga. Steel or min 1" Wood Plank Decks | 2 |
| | 15/32" Plywood Decks | 4 |
| 100-119 mph | 22-ga. Steel or 1" Wood Plank Decks | 4 |
| | 15/32" Plywood Decks | 6 |
| Projects located in Wind Zones greater than 119 mph or projects with a building height greater than 40 feet must be submitted to Carlisle for review prior to installation for applicable enhancements. | | |

* As an alternate to perimeter sheets, to match the number of rows, field sheets may be positioned around the building perimeter and a row fasteners and seam plates shall be positioned along the center of the width and secured a maximum of 12" on center. The appropriate cover strip shall be used to overlay the fasteners and plates.

** Projects incorporating other deck types should be submitted to Carlisle for review prior to installation.

D. Associated Installation Details

AFX EPDM Mechanically Fastened Membrane and End Lap SplicesAFX-MF1
 AFX TPO Mechanically Fastened Membrane and End Lap SplicesAFX-MF2

End of Attachment

MEMBRANE SPLICE

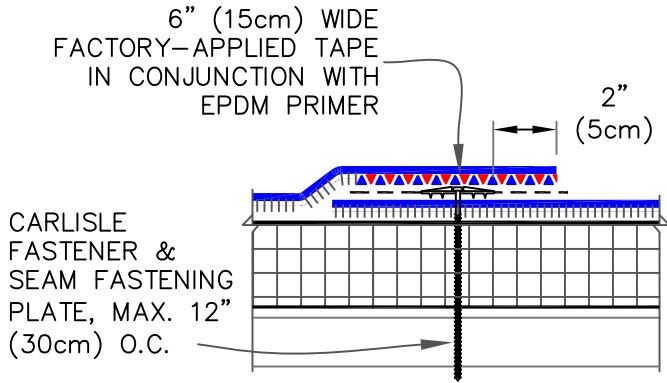

END LAP SPLICE

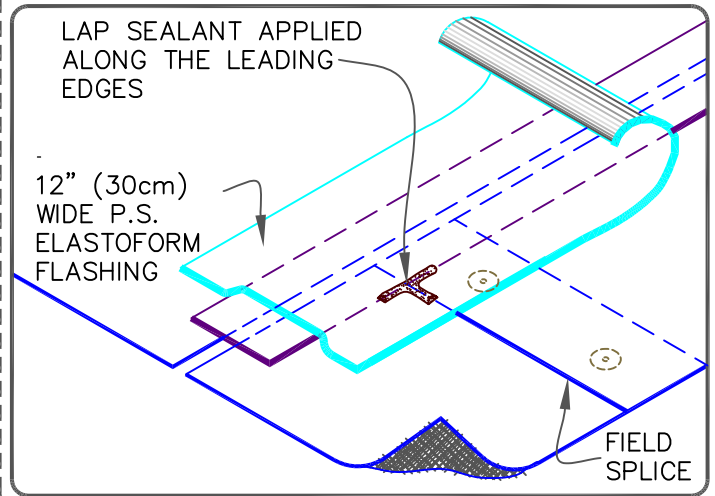
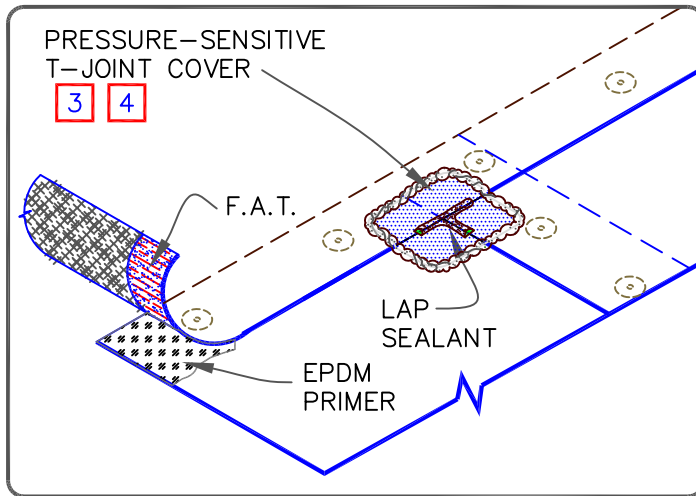
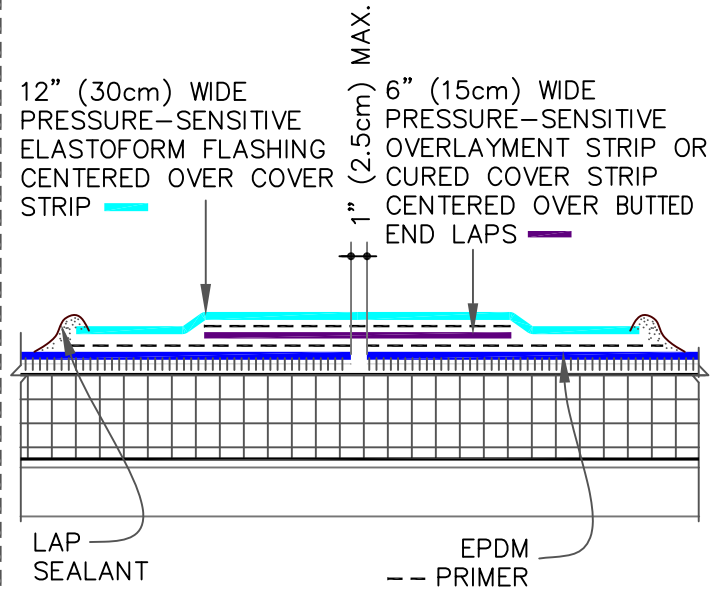

NOTES:

1. REFER TO CARLISLE SPECIFICATIONS FOR ACCEPTABLE CARLISLE FASTENER/PLATE AND FASTENING DENSITY.
2. APPLY EPDM PRIMER TO MEMBRANE SURFACES PRIOR TO INSTALLING PRESSURE-SENSITIVE FLASHING AND/OR FACTORY APPLIED SecurTAPE.
3. APPLY LAP SEALANT ALONG THE EDGE OF THE MEMBRANE SPLICE (UNDER THE 6"x6"(15cm X 15cm) T-JOINT COVER) COVERING THE EXPOSED SPLICE TAPE 1/2" (13 mm) IN EACH DIRECTION FROM THE SPLICE INTERSECTION.
4. 6" (15cm) WIDE PRESSURE-SENSITIVE ELASTOFOM FLASHING MAY ALSO BE CENTERED OVER THE FIELD SPLICE INTERSECTION.

| | | | | |
|----------|------------------------------|--|------------------------------|-------------------|
| | <p>—● AFX EPDM MEMBRANE</p> | <p>AFX EPDM MECHANICALLY FASTENED MEMBRANE & END LAP SPLICES</p> | | <p>DETAIL NO.</p> |
| | <p>—● APPROVED SUBSTRATE</p> | | | <p>AFX-MF1</p> |
| <p>0</p> | <p>—● SEE NOTE(S)</p> | <p>For additional information, refer to Specifications</p> | <p>MECHANICALLY FASTENED</p> | |

MEMBRANE SPLICE

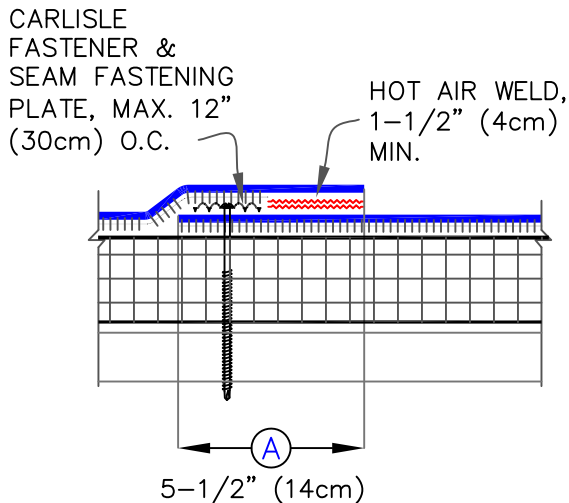

END LAP SPLICE

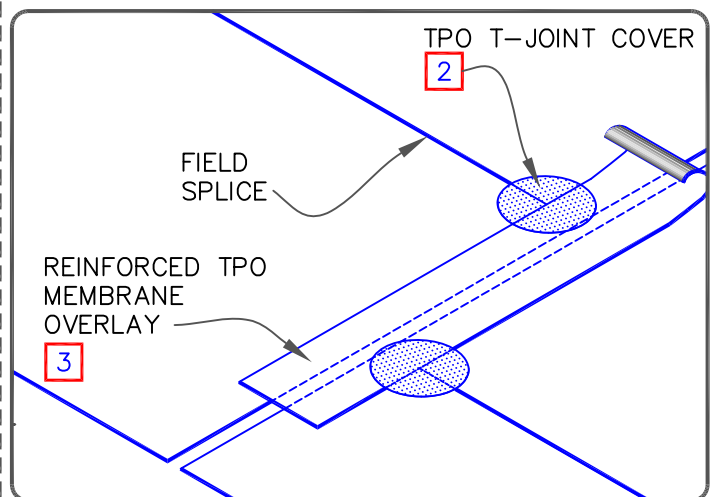
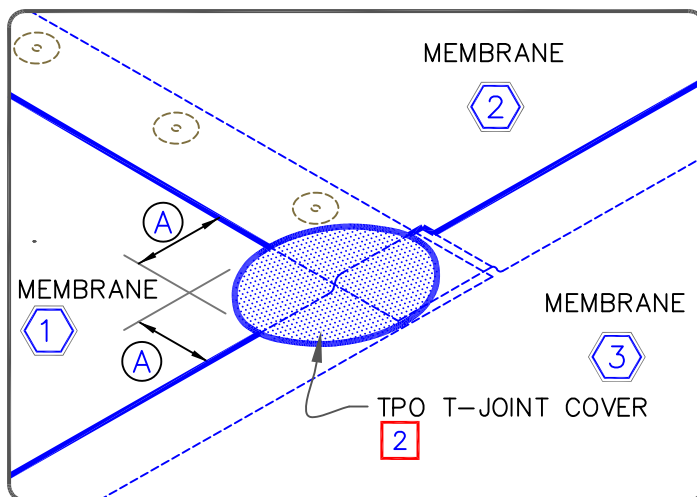
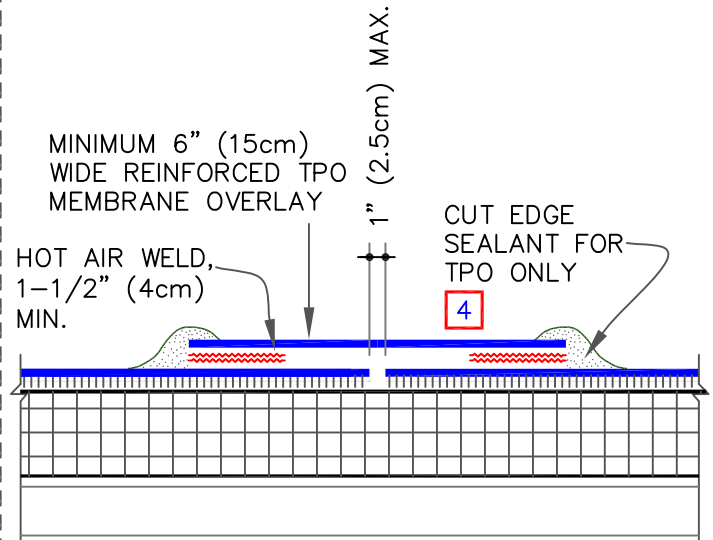

NOTES:

1. REFER TO CARLISLE SPECIFICATIONS FOR ACCEPTABLE CARLISLE FASTENER/PLATE AND FASTENING DENSITY.
2. WHEN USING 135 OR 155-MIL AFX TPO MEMBRANE, APPLY A 4-1/2" (11cm) DIAMETER TPO "T-JOINT" COVER AT ALL FIELD SPLICE INTERSECTIONS.
3. WHEN USING 60 OR 80 MIL TPO REINFORCED MEMBRANE OVERLAY, INTERSECTIONS BETWEEN SPLICES MUST BE OVERLAID WITH A 4-1/2" (11cm) DIAMETER TPO "T-JOINT" COVER, AS SHOWN.
4. APPROXIMATELY 1/8" (0.5cm) DIAMETER BEAD OF CUT-EDGE SEALANT IS REQUIRED ON CUT EDGES OF REINFORCED TPO MEMBRANE.

| | | |
|--|---|--|
| | <p>AFX TPO MECHANICALLY FASTENED MEMBRANE & END LAP SPLICES</p> <p>For additional information, refer to Specifications</p> | <p>DETAIL NO.</p> <p>AFX-MF2</p> <p>MECHANICALLY FASTENED</p> |
|--|---|--|

FleeceBACK® AFX

Roofing Systems

AFX EPDM / AFX Sure-Weld® Hot Mopped / Cold Applied Adhered Roofing System

Installation Details

Table of Contents

January 2024

| | Detail |
|--|---------------|
| Metal Edges and Gravel Stops | |
| SecurSeal Drip Edge Fascia | AFX-1A |
| SecurWeld Coated Drip Edge Fascia -TPO | AFX-1B |
| Metal Bar Edge Termination..... | AFX-1C |
| Carlisle SecurEdge 200..... | AFX-1D |
| Carlisle SecurEdge 300..... | AFX-1E |
| Carlisle SecurEdge 2000 & 3000 | AFX-1F |
| Membrane Splices | |
| EPDM Membrane Splices – Projects with 10,15 and 20-Year Warranties | AFX-2A |
| EPDM Membrane Splices – Projects with 25-Year Warranties | AFX-2A.1 |
| TPO Membrane Splices | AFX-2B |
| Expansion Joints | |
| Deck-to-Deck Expansion Joint | AFX-3A |
| Deck-to-Wall Expansion Detail | AFX-3B |
| Drains | |
| Roof Drain with Continuous Membrane..... | AFX-6A |
| Roof Drain with Separate Target Splice | AFX-6B |
| Pipe Flashing | |
| Pre-Molded Pipe Seals..... | AFX-8A |
| Field Fabricated Pipe Flashing | AFX-8B |
| Termination | |
| Membrane Terminations (Page 1 of 2)..... | AFX-9 |
| Membrane Terminations (Page 2 of 2)..... | AFX-9 |
| Parapet / Curb Flashing | |
| Parapet/Curb with Separate Membrane Flashing | AFX-12A |
| Parapet/Curb with Continuous Membrane Flashing | AFX-12B |
| Inside / Outside Corners | |
| EPDM Pressure-Sensitive Inside Corner | AFX-15A |
| EPDM Pressure-Sensitive Outside Corner..... | AFX-15B |
| TPO Pre-Molded Inside Corner | AFX-15C |
| TPO Pre-Molded Outside Corner | AFX-15D |
| Sealant Pocket | |
| EPDM Pressure-Sensitive Pourable Sealer Pocket | AFX-16A |
| TPO Molded Sealant Pocket | AFX-16B |
| Through-Wall Scupper | |
| Through-Wall Scupper with Pressure-Sensitive EPDM Flashing | AFX-18A |

| | |
|--|---------|
| Through-Wall Scupper with SecurWeld Metal..... | AFX-18B |
| AFX EPDM Mechanically Fastened Membrane & End Lap Splices | AFX-MF1 |
| AFX TPO Mechanically Fastened Membrane and End Lap Splices | AFX-MF2 |

CAUTION

DETAIL NOT FOR USE ON 25-YEAR WARRANTY PROJECTS. ACCEPTABLE EDGING SHALL CONFORM WITH THERMOSET DETAIL [U-1A.1](#) WHEN USING EPDM MEMBRANE OR [AFX-1B](#) WITH TPO MEMBRANE.

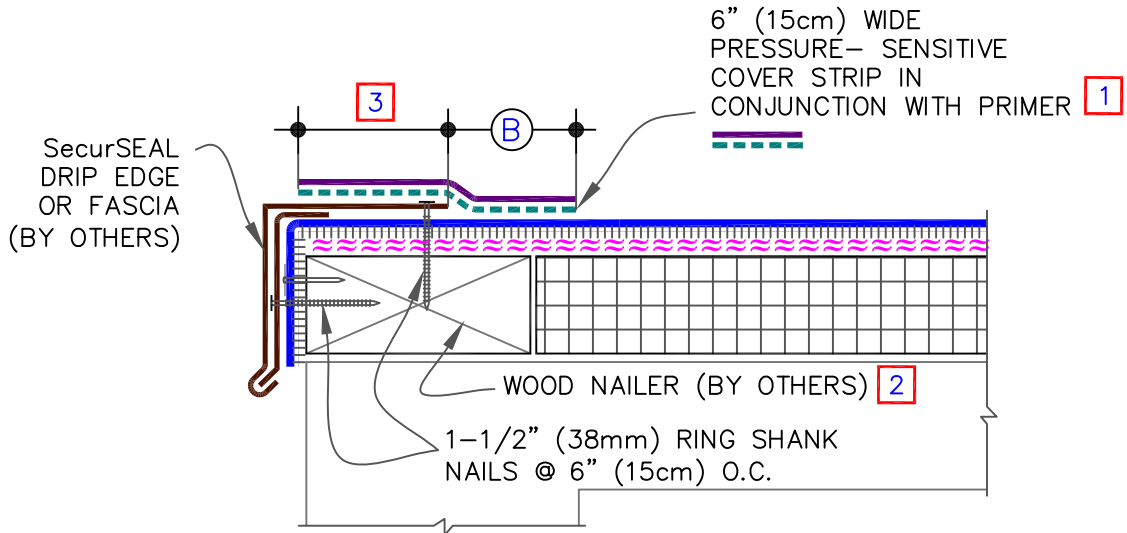

NOTES:

1. USE APPROPRIATE COVER STRIP & PRIMER BASED UPON MEMBRANE TYPE. FOR EPDM, REFER TO [THERMOSET U-1A](#). FOR TPO, REFER TO [THERMOPLASTIC U-1A](#).
2. WOOD NAILER MUST EXTEND PAST TOTAL WIDTH OF METAL FASCIA DECK FLANGE.
3. METAL FASCIA DECK FLANGE MUST BE TOTALLY COVERED BY PRESSURE-SENSITIVE COVER STRIP WITH MINIMUM 2" (5cm) COVERAGE PAST NAIL HEADS.
4. TO REMOVE FINISHING OILS, SCRUB METAL FLANGE WITH WEATHERED MEMBRANE CLEANER; ALLOW TO DRY PRIOR TO APPLYING PRIMER.
5. APPLY PRIMER TO METAL FLANGE AND MEMBRANE SURFACE PRIOR TO INSTALLING PRESSURE-SENSITIVE FLASHING.
6. WHEN METAL FASCIA BY OTHERS IS USED, FASTENER TYPE AND FASTENING FREQUENCY SHALL BE RECOMMENDED BY METAL EDGE MANUFACTURER.

| DIMENSIONS | | cm | |
|------------|------|-----|------|
| (A) | 1/2" | 1.5 | TO |
| | 1" | 2.5 | |
| (B) | 2" | 5 | MIN. |

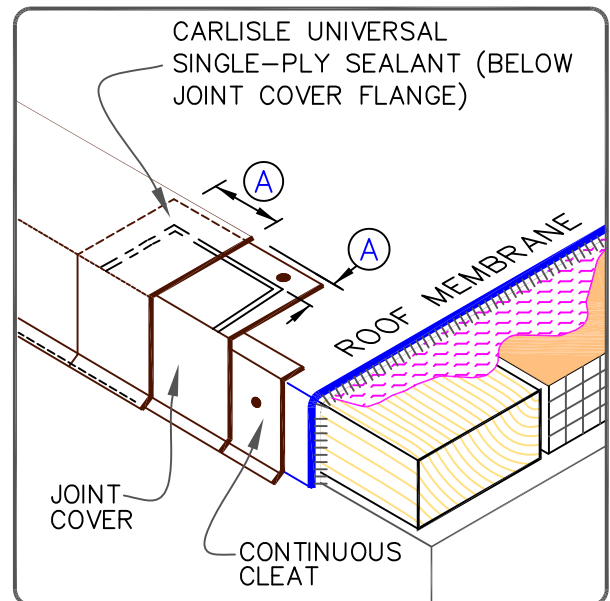

SecurSEAL DRIP EDGE FASCIA

MAXIMUM WARRANTY: 20 YEARS



DETAIL NO.

AFX-1A

AFX ADHERED

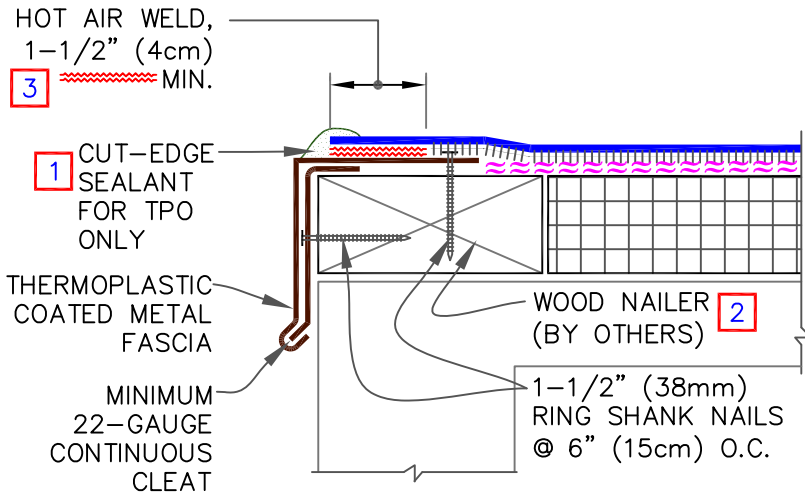

NOTES:

1. APPROXIMATELY 1/8" (0.5cm) DIAMETER BEAD OF CUT-EDGE SEALANT IS REQUIRED ON CUT EDGES OF REINFORCED TPO MEMBRANE.
2. WOOD NAILER MUST EXTEND PAST TOTAL WIDTH OF METAL FASCIA DECK FLANGE.
3. POSITION MEMBRANE WITH SELVAGE EDGE TO AVOID REMOVAL OF FLEECE BACKING.

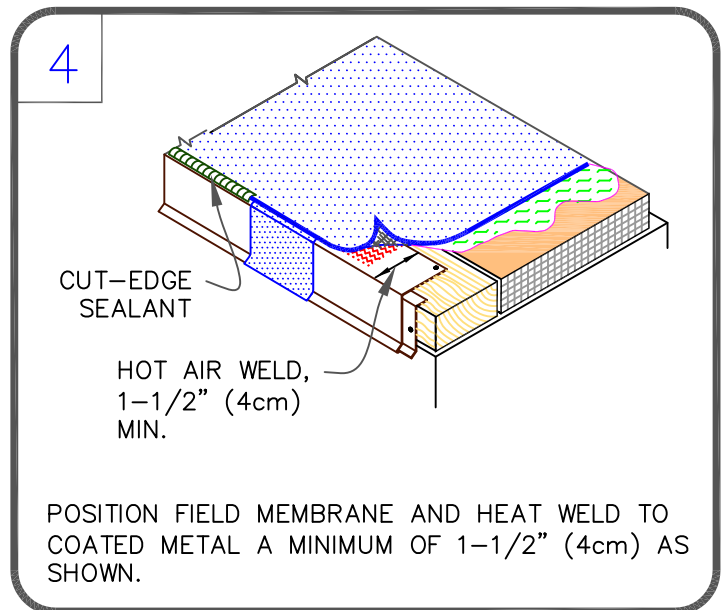
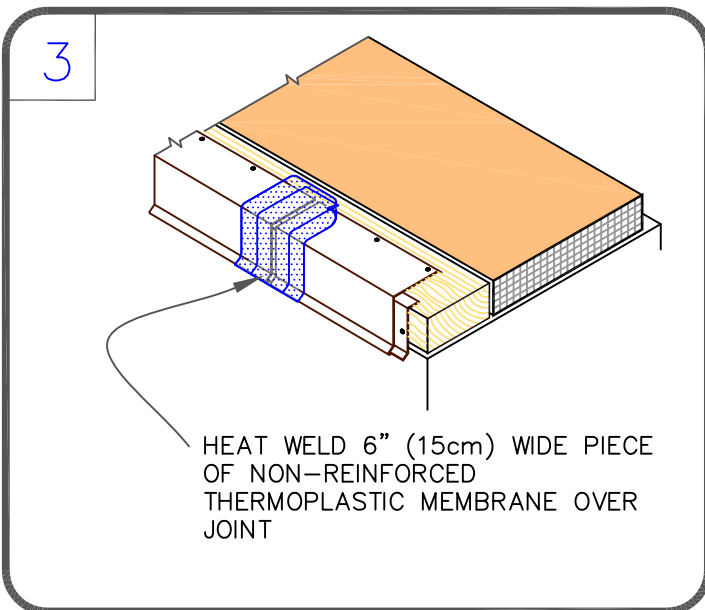
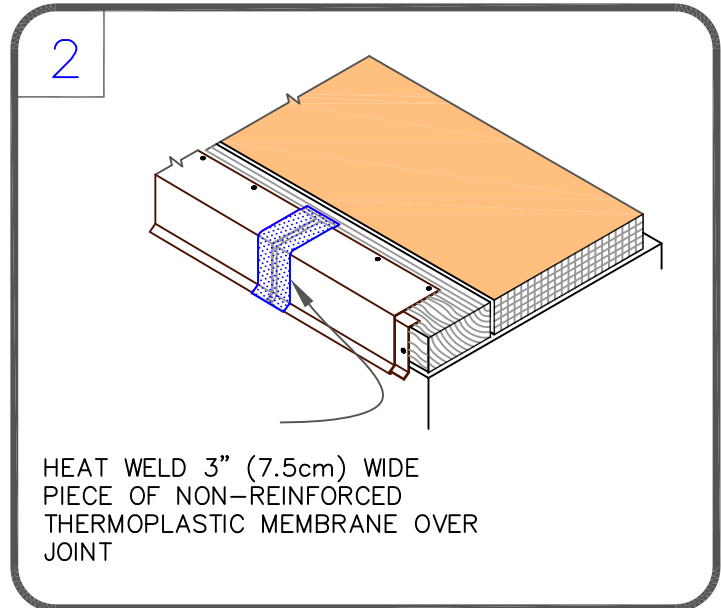
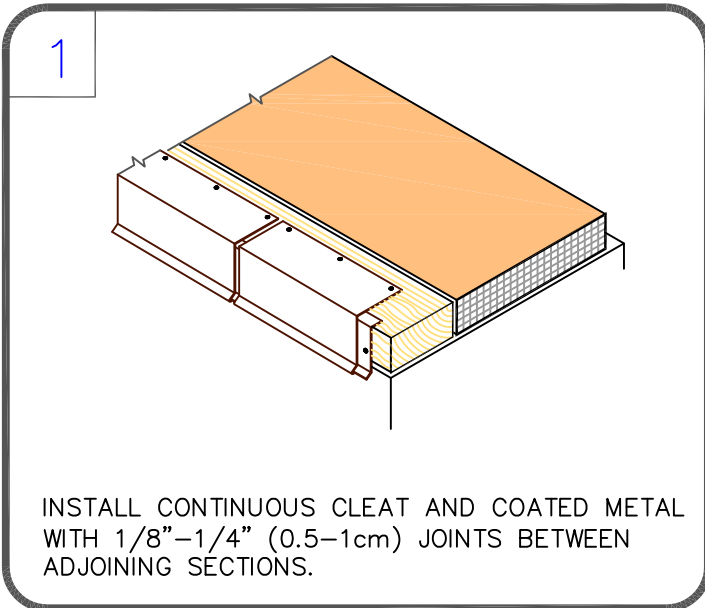

SecurWELD COATED DRIP EDGE FASCIA - TPO

MAXIMUM WARRANTY: 30 YEARS



DETAIL NO.

AFX-1B

AFX ADHERED

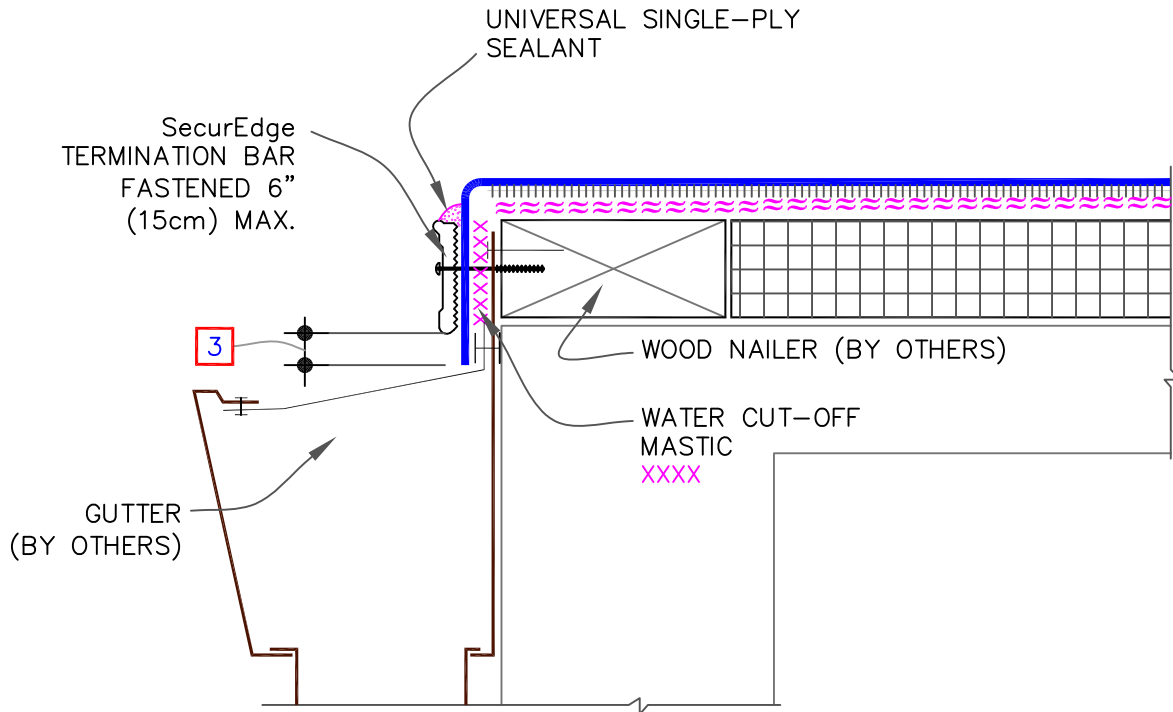

NOTES:

1. POSITION MEMBRANE WITH SELVAGE EDGE AT TERMINATION BAR LOCATION TO AVOID REMOVAL OF FLEECE BACKING.
2. FASTENING OF METAL TERMINATION BAR MUST PROVIDE CONSTANT COMPRESSION ON WATER CUT-OFF MASTIC.
3. ALLOW MEMBRANE SHEET TO EXTEND 1/2" (1.5cm) MINIMUM BELOW THE METAL TERMINATION BAR.

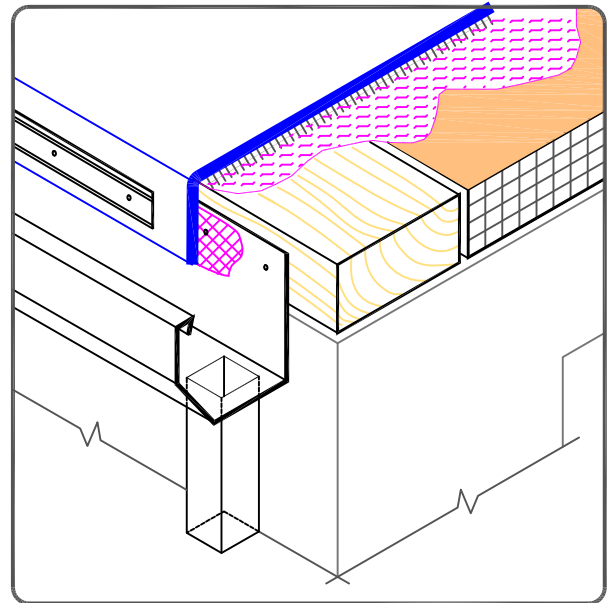

METAL BAR EDGE TERMINATION

MAXIMUM WARRANTY: 30 YEARS



DETAIL NO.

AFX-1C

AFX ADHERED

CAUTION

FOR PROJECTS WITH 25-YEAR WARRANTIES, ALL EPDM SPLICE INTERSECTIONS MUST BE OVERLAID WITH TWO LAYERS OF PRESSURE-SENSITIVE ELASTOFORM FLASHING. THE BOTTOM LAYER SHALL BE 6"X6" (15cm X 15cm) COVERED WITH A 12"X12" TOP LAYER (30cm X 30cm). BOTH LAYERS SHALL BE CENTERED OVER THE SPLICE INTERSECTION AND SEALED WITH CONTINUOUS LAP SEALANT.

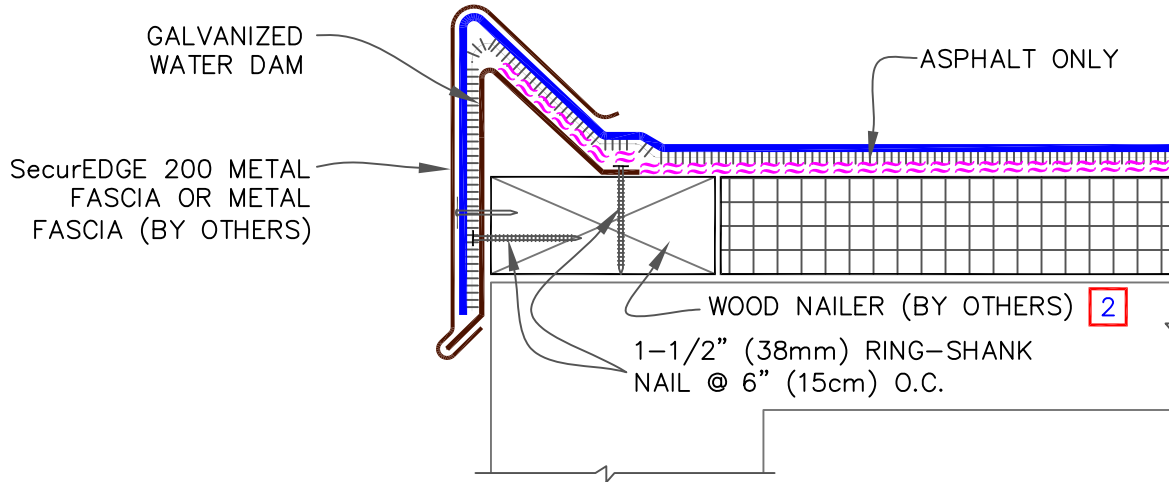

NOTES:

1. REFER TO [SecurEdge 200 INSTALLATION INSTRUCTION MANUAL](#) FOR STEP-BY-STEP INSTALLATION PROCEDURES.
2. WOOD NAILER MUST EXTEND PAST TOTAL WIDTH OF GRAVEL STOP DECK FLANGE.
3. WHEN METAL FASCIA BY OTHERS IS USED, FASTENER TYPE AND FASTENING FREQUENCY SHALL BE RECOMMENDED BY METAL EDGE MANUFACTURER.

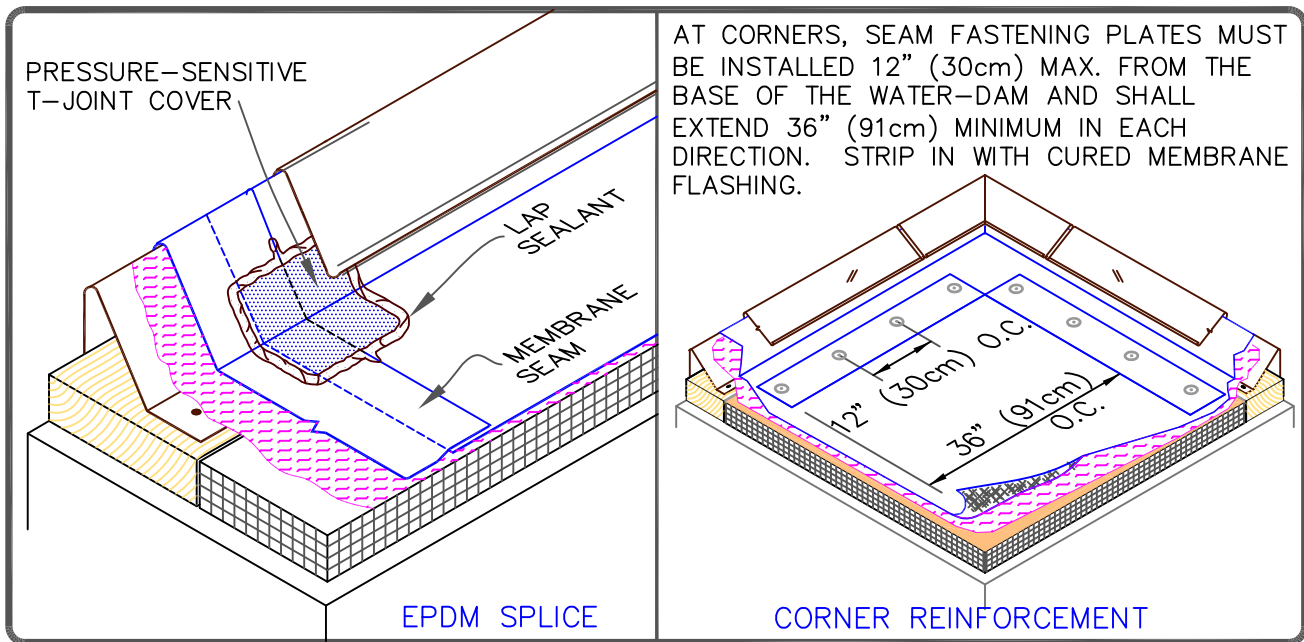

| | | | |
|--|----------------------------|-------------|------------|
| | CARLISLE SecurEdge 200 | | DETAIL NO. |
| | MAXIMUM WARRANTY: 30 YEARS | | AFX-1D |
| | | AFX ADHERED | |

CAUTION

EPDM MEMBRANE SPLICES SHALL INCORPORATE 6" (15cm) WIDE FIELD APPLIED SecurTAPE FOR PROJECTS WITH 20 AND 25-YEAR WARRANTIES.

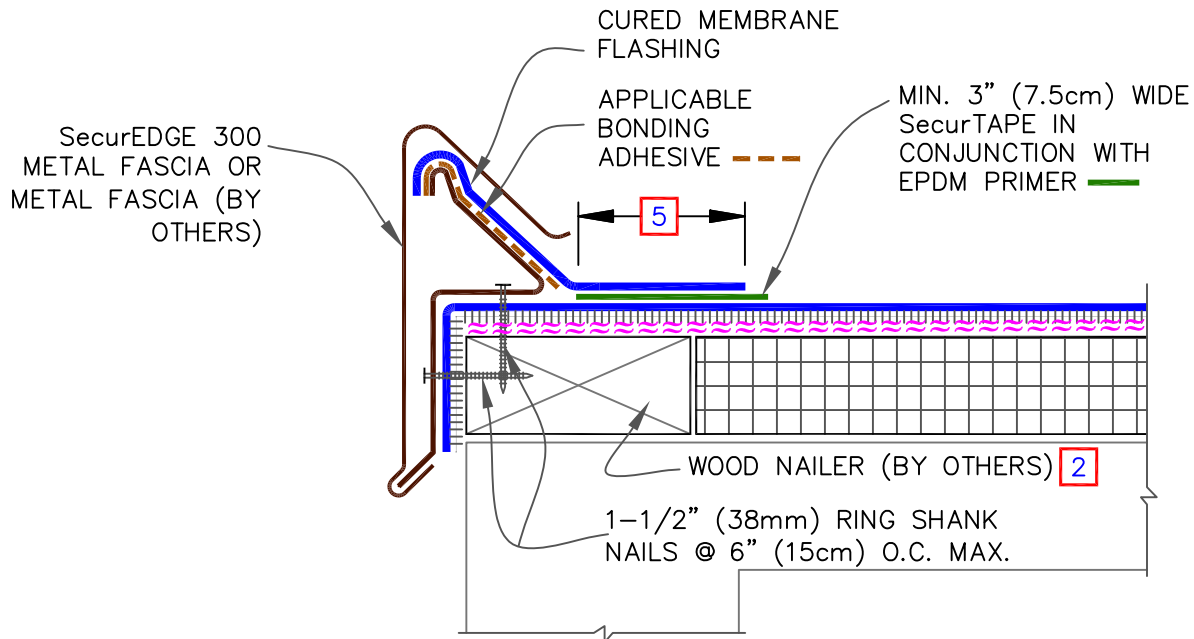

NOTES:

1. REFER TO [SecurEdge 300 INSTALLATION INSTRUCTION MANUAL](#) FOR STEP-BY-STEP INSTALLATION PROCEDURES.
2. WOOD NAILER MUST EXTEND PAST TOTAL WIDTH OF GRAVEL STOP DECK FLANGE.
3. PRESSURE-SENSITIVE T-JOINT COVER OR 6" (15cm) WIDE PRESSURE-SENSITIVE FLASHING, IN CONJUNCTION WITH EPDM PRIMER, MUST BE CENTERED OVER EPDM FIELD SPLICES AT THE ANGLE CHANGE. PROJECTS WITH 25-YEAR WARRANTIES REQUIRE EPDM FIELD SPLICES TO BE OVERLAID WITH TWO LAYERS OF PRESSURE-SENSITIVE ELASTOFORM FLASHING. THE BOTTOM LAYER SHALL BE 6" (15cm) WIDE COVERED WITH A 12" WIDE TOP LAYER (30cm). BOTH LAYERS SHALL BE CENTERED AND SEALED WITH CONTINUOUS LAP SEALANT.
4. WHEN METAL FASCIA BY OTHERS IS USED, FASTENER TYPE AND FASTENING FREQUENCY SHALL BE RECOMMENDED BY METAL EDGE MANUFACTURER.
5. MEMBRANE SPLICES SHALL BE COMPLETED USING MINIMUM 3" (7.5cm) WIDE SecurTAPE/EPDM PRIMER WITH EPDM MEMBRANE AND MINIMUM 1-1/2" (4cm) HOT AIR WELD WITH TPO/KEE HP.
6. APPROXIMATELY 1/8" (0.5cm) DIAMETER BEAD OF CUT EDGE SEALANT IS REQUIRED ON CUT EDGES OF REINFORCED TPO MEMBRANE.

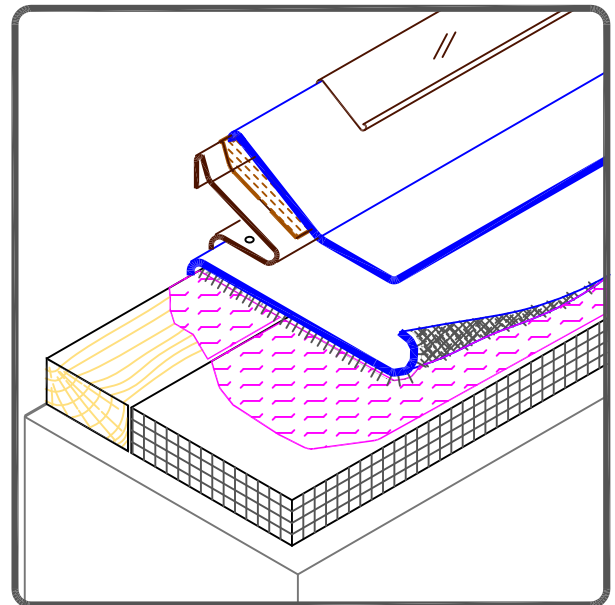

CARLISLE SecurEdge 300

MAXIMUM WARRANTY: 30 YEARS



DETAIL NO.

AFX-1E

AFX ADHERED

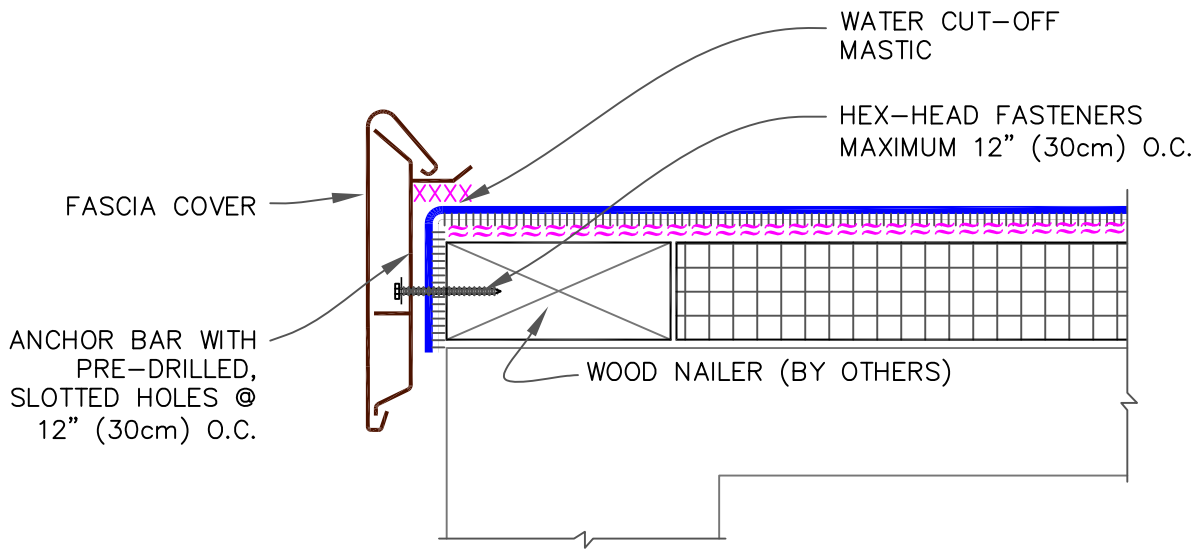

SecurEDGE 2000

NOTES:

1. REFER TO [SecurEdge 2000 OR 3000 INSTRUCTION MANUALS](#) FOR THE STEP BY STEP INSTALLATION PROCEDURES.
2. IF INCIDENTAL/TEMPORARY PONDED WATER IS EXPECTED, THE SecurEdge MUST BE ELEVATED AND SCUPPERS PROVIDED FOR DRAINAGE.
3. ENSURE ROOF SLOPES AWAY FROM SecurEDGE.

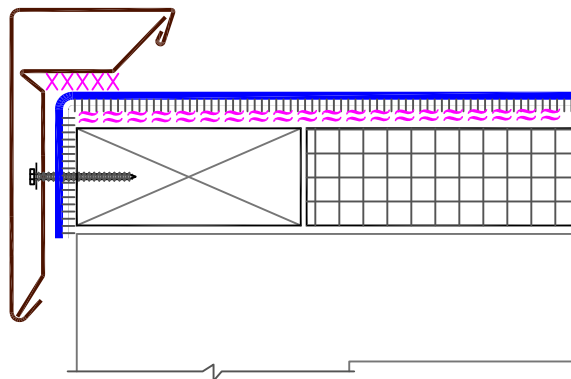

SecurEDGE 3000



CARLISLE SecurEdge 2000 & 3000

MAXIMUM WARRANTY: 30 YEARS



DETAIL NO.

AFX-1F

AFX ADHERED

MEMBRANE SPLICE

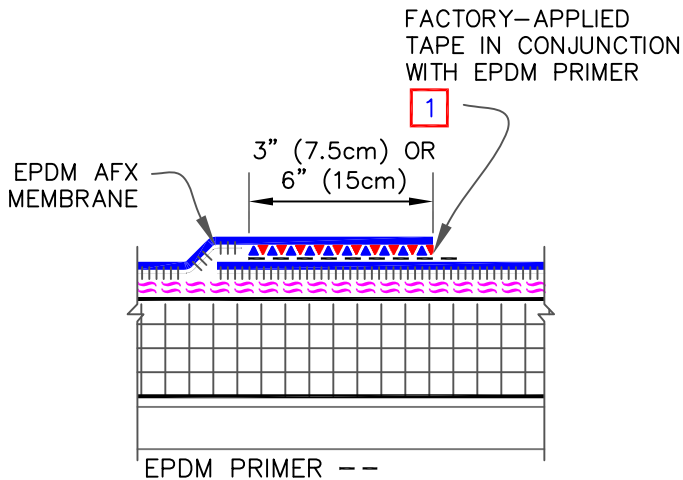

END LAP SPLICE

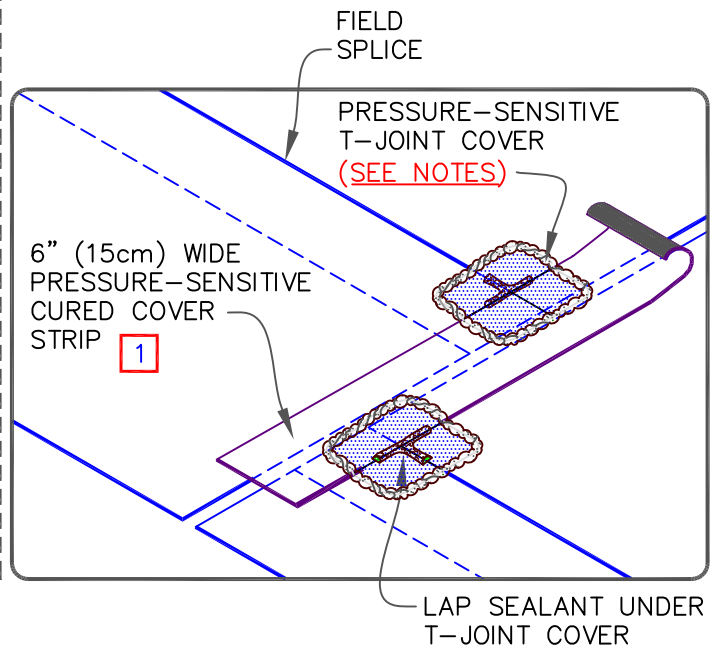
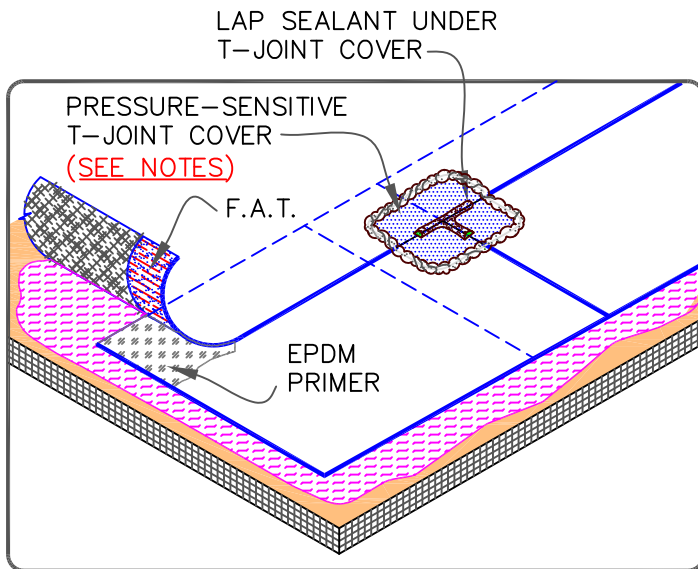
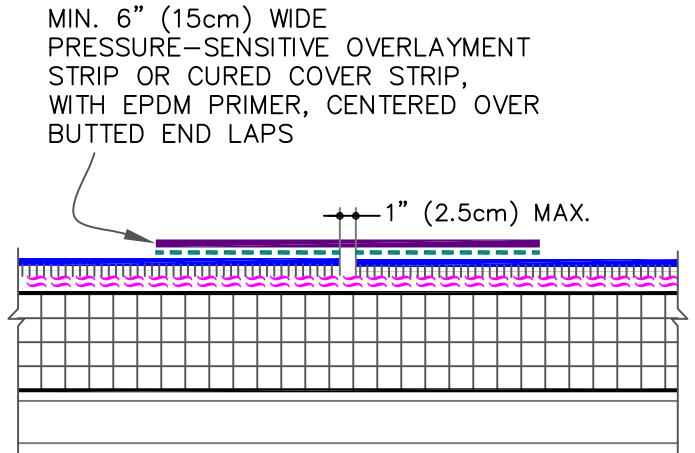

NOTES:

1. APPLY EPDM PRIMER TO MEMBRANE SURFACES PRIOR TO INSTALLING PRESSURE-SENSITIVE FLASHING AND/OR FACTORY APPLIED SecurTAPE.
2. APPLY LAP SEALANT ALONG THE EDGE OF THE MEMBRANE SPLICE (UNDER THE 6"x6" (15cm x 15cm) T-JOINT COVER) COVERING THE EXPOSED SPLICE TAPE 1/2" (1.5cm) IN EACH DIRECTION FROM THE SPLICE INTERSECTION.
3. 6" (15cm) WIDE PRESSURE-SENSITIVE ELASTOFORM FLASHING MAY ALSO BE CENTERED OVER THE FIELD SPLICE INTERSECTION.



AFX EPDM MEMBRANE SPLICE

MAXIMUM WARRANTY: 20 YEARS



DETAIL NO.

AFX-2A

AFX ADHERED

MEMBRANE SPLICE

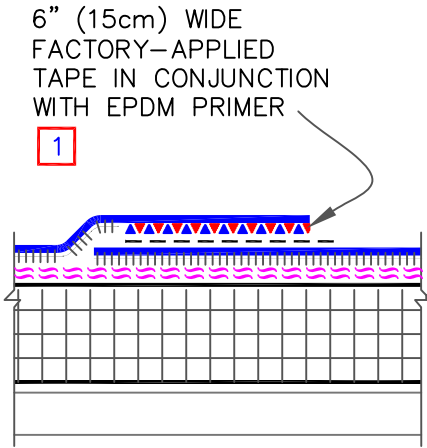

END LAP SPLICE

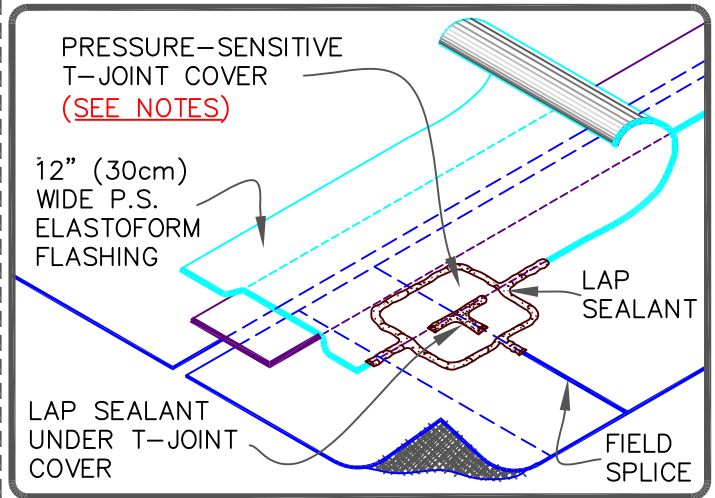
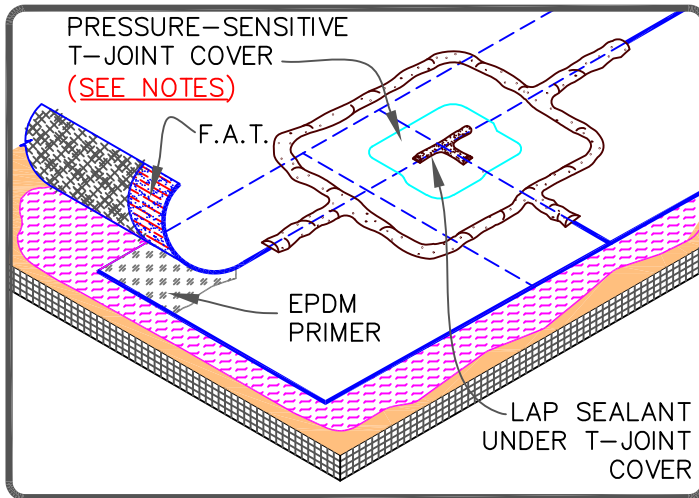
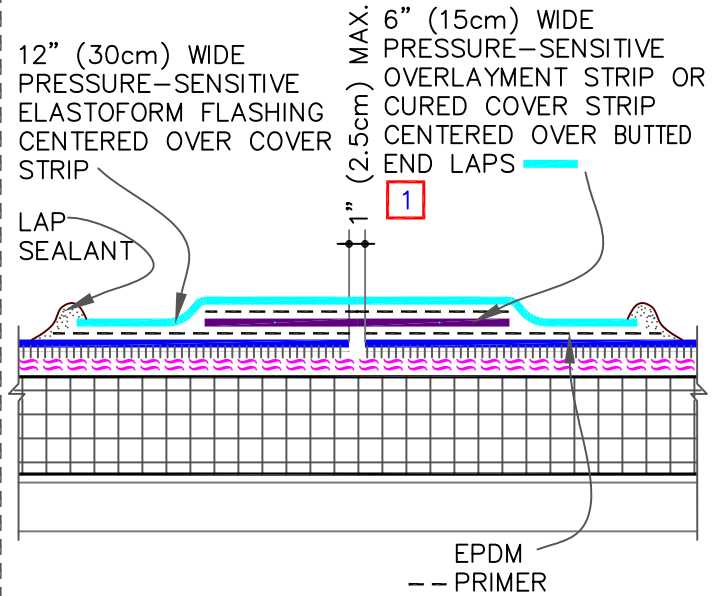

NOTES:

1. APPLY EPDM PRIMER TO MEMBRANE SURFACES PRIOR TO INSTALLING PRESSURE-SENSITIVE FLASHING AND/OR FACTORY APPLIED SecurTAPE.
2. APPLY LAP SEALANT ALONG THE EDGE OF THE MEMBRANE SPLICE (UNDER THE 6"x6"(15cm X 15cm) T-JOINT COVER) COVERING THE EXPOSED SPLICE TAPE 1/2" (1.5cm) IN EACH DIRECTION FROM THE SPLICE INTERSECTION.
3. ALL EPDM SPLICE INTERSECTIONS MUST BE OVERLAID WITH TWO LAYERS OF PRESSURE-SENSITIVE ELASTOFOM FLASHING. THE BOTTOM LAYER SHALL BE 6"x6" (15cm X 15cm) COVERED WITH A 12"x12" (30cm X 30cm) TOP LAYER (30cm X 30cm). BOTH LAYERS SHALL BE CENTERED OVER THE SPLICE INTERSECTION AND SEALED WITH CONTINUOUS LAP SEALANT, AS SHOWN.



AFX EPDM MEMBRANE SPLICE
(25-YEAR WARRANTIES)

MAXIMUM WARRANTY: 30 YEARS



DETAIL NO.

AFX-2A.1

AFX ADHERED

MEMBRANE SPLICE

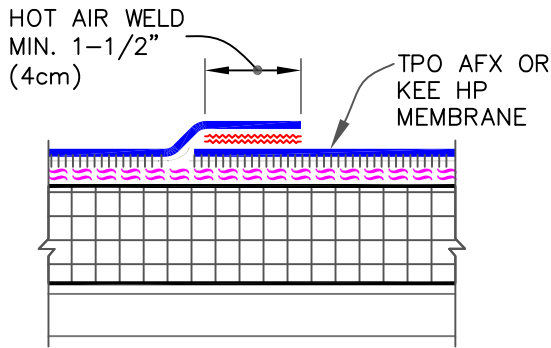

| DIMENSION | cm | |
|-----------|--------|---|
| (A) | 2-1/4" | 6 |

END LAP SPLICE

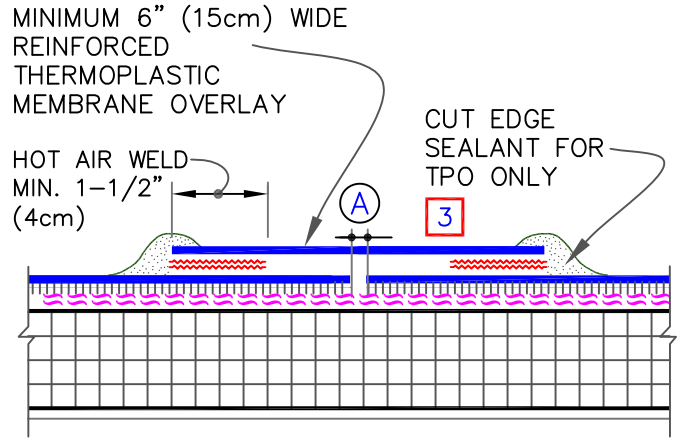

| DIMENSION | cm | |
|-----------|----|----------|
| (A) | 1" | 2.5 MAX. |

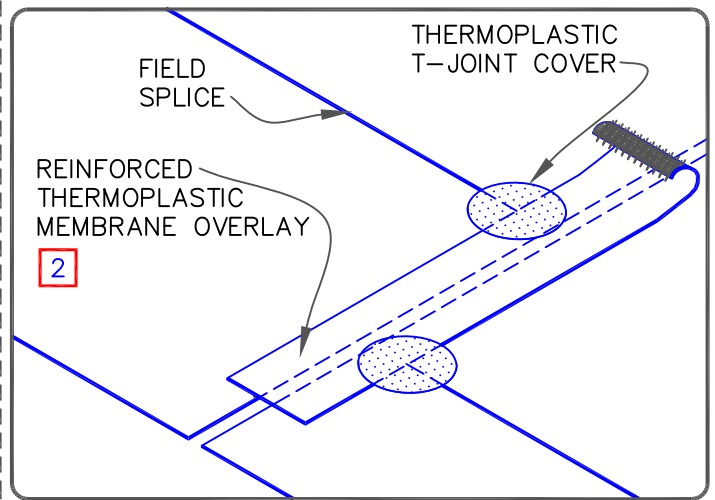
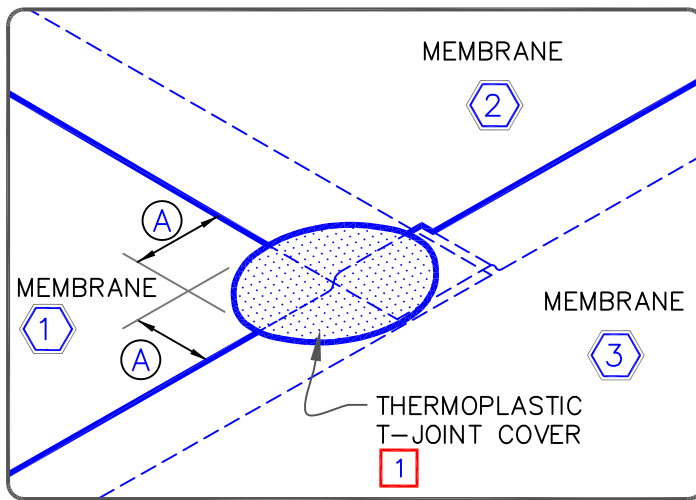

NOTES:

1. WHEN USING 115, 135 OR 155-MIL TPO AFX OR FleeceBACK KEE HP, APPLY A 4-1/2" (11cm) DIAMETER TPO "T-JOINT" COVER AT ALL FIELD SPLICE INTERSECTIONS.
2. WHEN USING 60 OR 80 MIL TPO REINFORCED MEMBRANE OVERLAY, INTERSECTIONS BETWEEN SPLICES MUST BE OVERLAID WITH A 4-1/2" (11cm) DIAMETER TPO "T-JOINT" COVER.
3. APPROXIMATELY 1/8" (0.5cm) DIAMETER BEAD OF CUT-EDGE SEALANT IS REQUIRED ON CUT EDGES OF TPO REINFORCED MEMBRANE.



TPO MEMBRANE SPLICES

MAXIMUM WARRANTY: 30 YEARS



DETAIL NO.

AFX-2B

AFX ADHERED

CAUTION

EPDM MEMBRANE SPLICES SHALL INCORPORATE 6" (15cm) WIDE FIELD APPLIED SecurTAPE FOR PROJECTS WITH 20 AND 25-YEAR WARRANTIES.

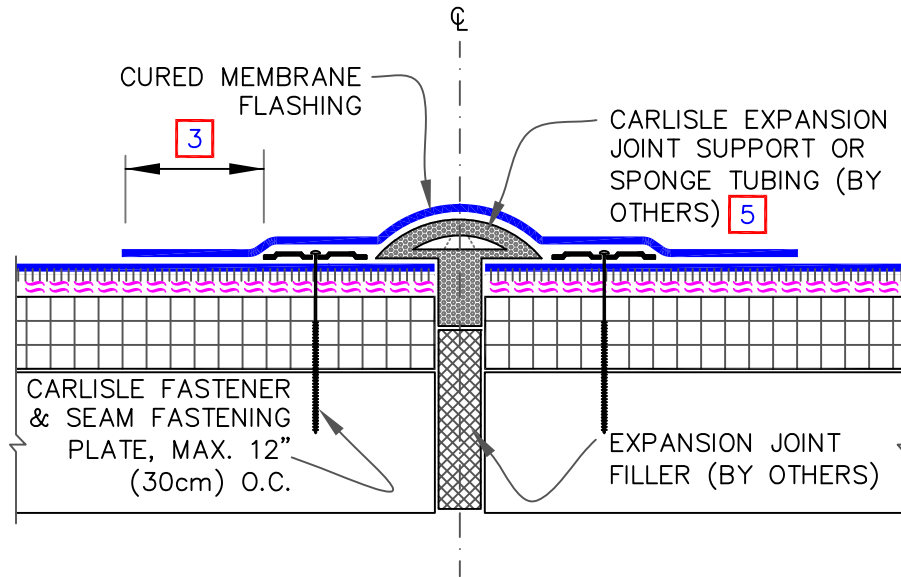



NOTES:

1. WHEN CARLISLE EXPANSION JOINT SUPPORT IS USED, WIDTH OF JOINT SHALL BE A MINIMUM OF 3/4" (2cm) AND SHALL NOT EXCEED 3" (7.5cm).
2. APPROXIMATELY 1/8" (0.5cm) DIAMETER BEAD OF CUT-EDGE SEALANT IS REQUIRED ON CUT EDGES OF REINFORCED TPO MEMBRANE.
3. MEMBRANE SPLICES SHALL BE COMPLETED USING MINIMUM 3" (7.5cm) WIDE SecurTAPE/ PRIMER WITH EPDM MEMBRANE AND MINIMUM 1-1/2" (4cm) HOT AIR WELD WITH TPO.
4. WHEN USING 60 OR 80-MIL REINFORCED TPO MEMBRANE FLASHING, APPLY A 4-1/2" (11cm) DIAMETER TPO "T-JOINT" COVER AT ALL FIELD SPLICE INTERSECTIONS.

ALL EPDM SPLICE INTERSECTIONS MUST BE OVERLAID WITH A PRESSURE-SENSITIVE T-JOINT COVER. PRIOR TO DOING SO, APPLY LAP SEALANT ALONG THE EDGE OF THE MEMBRANE SPLICE (UNDER THE 6"x6" T-JOINT COVER) COVERING THE EXPOSED SPLICE TAPE 2" (5cm) IN EACH DIRECTION FROM THE SPLICE INTERSECTION. PROJECTS WITH 25-YEAR WARRANTIES MUST BE OVERLAID WITH TWO LAYERS OF PRESSURE-SENSITIVE ELASTOFORM FLASHING. THE BOTTOM LAYER SHALL BE 6"x6" (15cm X 15cm) COVERED WITH A 12"x12" TOP LAYER (30cm X 30cm). BOTH LAYERS SHALL BE CENTERED OVER THE SPLICE INTERSECTION AND SEALED WITH CONTINUOUS LAP SEALANT, [REFER TO AFX-2 DETAILS](#).

5. ROOF MEMBRANE SHALL NOT BE ADHERED OVER THE EXPANSION JOINT SUPPORT OR SPONGE TUBING.
6. FOR EPDM APPLICATIONS, USE TWO LAYERS OF PRESSURE-SENSITIVE ELASTOFORM FLASHING WITH EACH LAYER 3" (7.5cm) LARGER THAN THE PREVIOUS LAYER IN ALL DIRECTIONS FOR EXPANSION JOINT INTERSECTIONS BETWEEN EXPANSION JOINTS TO WALL OR EDGING.

| | | | |
|--|------------------------------|---|------------|
|  | DECK-TO-DECK EXPANSION JOINT |  | DETAIL NO. |
| | MAXIMUM WARRANTY: 30 YEARS | | AFX-3A |
| | | AFX ADHERED | |

CAUTION

EPDM MEMBRANE SPLICES SHALL INCORPORATE 6" (15cm) WIDE FIELD APPLIED SecurTAPE FOR PROJECTS WITH 20 AND 25-YEAR WARRANTIES.

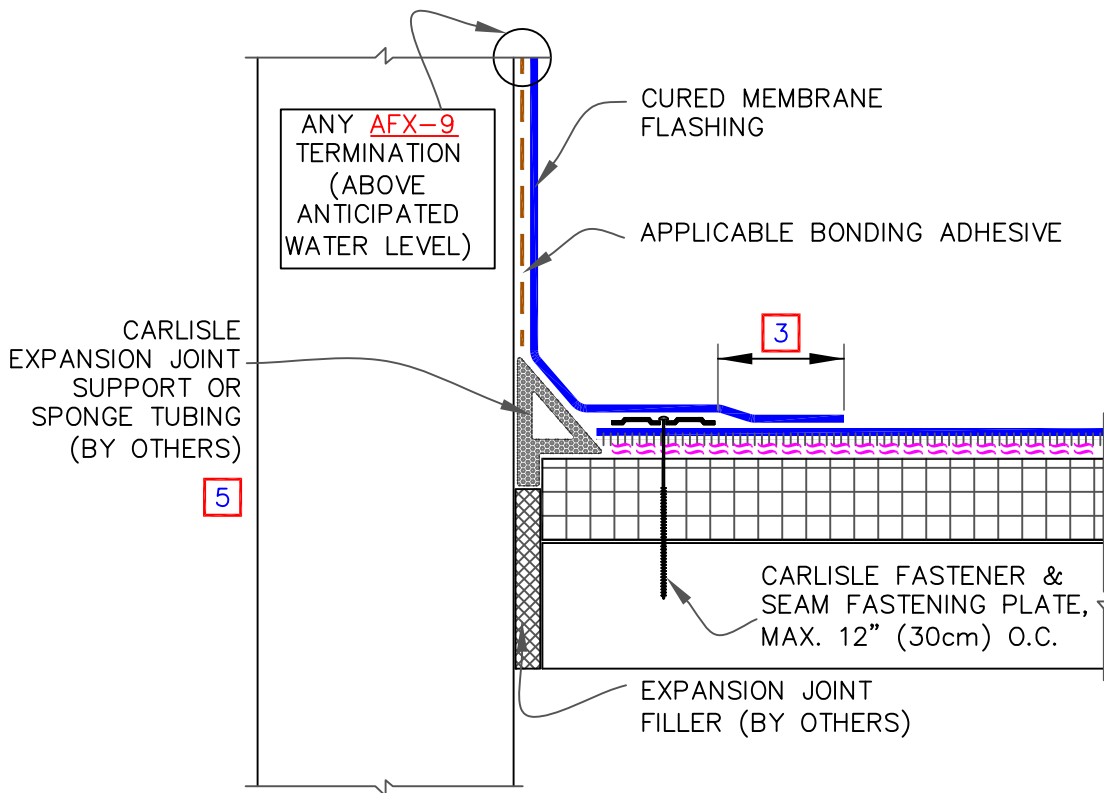

NOTES:

1. WHEN CARLISLE EXPANSION JOINT SUPPORT IS USED, WIDTH OF JOINT SHALL BE A MINIMUM OF 3/4" (2cm) AND SHALL NOT EXCEED 2" (5cm).
2. APPROXIMATELY 1/8" (0.5cm) DIAMETER BEAD OF CUT-EDGE SEALANT IS REQUIRED ON CUT EDGES OF REINFORCED TPO MEMBRANE.
3. SPLICES SHALL BE COMPLETED USING MINIMUM 3" (7.5cm) WIDE SecurTAPE/ PRIMER WITH EPDM MEMBRANE AND MINIMUM 1-1/2" (4cm) HOT AIR WELD WITH TPO.
4. WHEN USING 60 OR 80-MIL TPO AND 80-MIL KEE HP REINFORCED THERMOPLASTIC MEMBRANE FLASHING, APPLY A 4-1/2" (11cm) DIAMETER THERMOPLASTIC "T-JOINT" COVER AT ALL FIELD SPLICE INTERSECTIONS.

ALL EPDM SPLICE INTERSECTIONS MUST BE OVERLAID WITH A PRESSURE-SENSITIVE T-JOINT COVER. PRIOR TO DOING SO, APPLY LAP SEALANT ALONG THE EDGE OF THE MEMBRANE SPLICE (UNDER THE 6"x6" (15cm x15cm) T-JOINT COVER) COVERING THE EXPOSED SPLICE TAPE 2" (5cm) IN EACH DIRECTION FROM THE SPLICE INTERSECTION. PROJECTS WITH 25-YEAR WARRANTIES MUST BE OVERLAID WITH TWO LAYERS OF PRESSURE-SENSITIVE ELASTOFORM FLASHING. THE BOTTOM LAYER SHALL BE 6"x6" (15cm X 15cm) COVERED WITH A 12"x12" TOP LAYER (30cm X 30cm). BOTH LAYERS SHALL BE CENTERED OVER THE SPLICE INTERSECTION AND SEALED WITH CONTINUOUS LAP SEALANT, REFER TO AFX-2 DETAILS.

5. ROOF MEMBRANE SHALL NOT BE ADHERED OVER THE EXPANSION JOINT SUPPORT OR SPONGE TUBING.

| | | | |
|--|------------------------------|-------------|------------|
| | DECK-TO-WALL EXPANSION JOINT | | DETAIL NO. |
| | MAXIMUM WARRANTY: 30 YEARS | | AFX-3B |
| | | AFX ADHERED | |

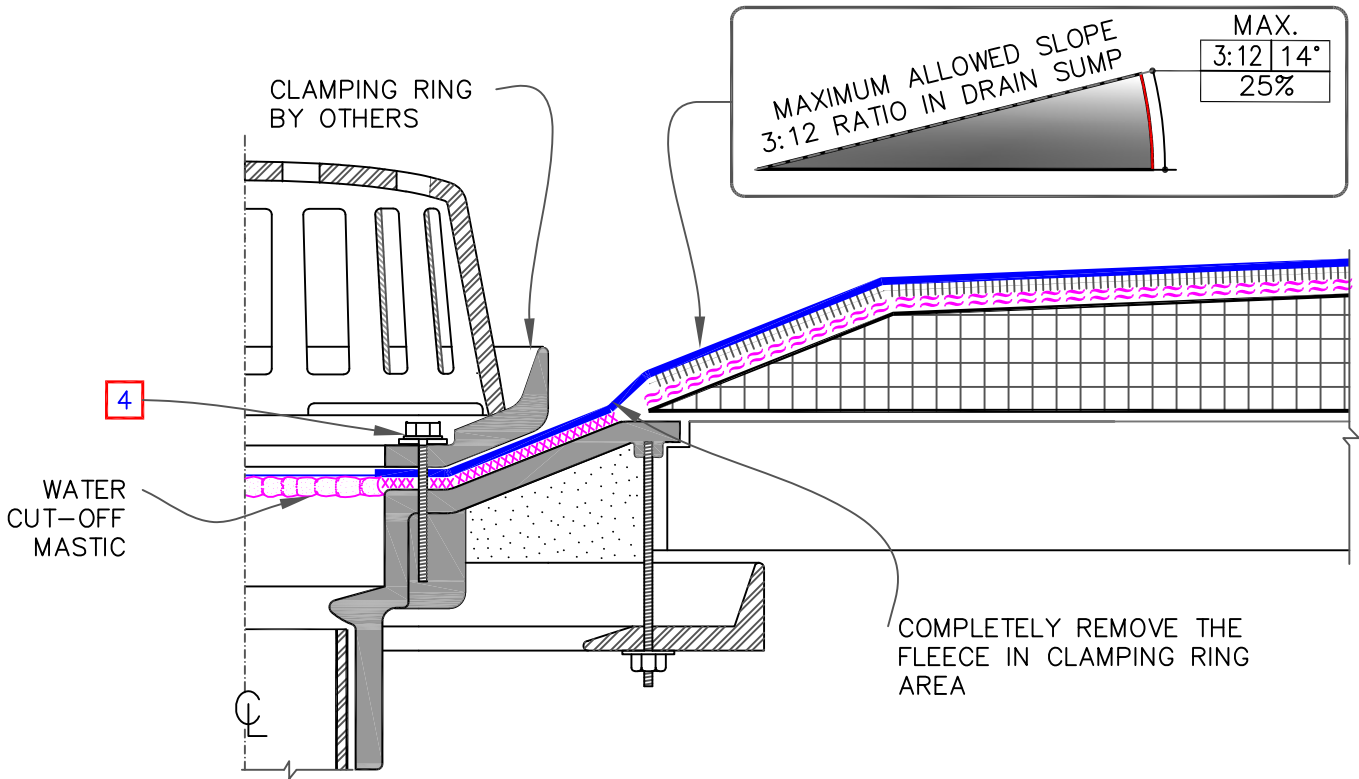

NOTES:

1. REMOVE EXISTING LEAD, FLASHING MATERIAL & ENSURE THE DRAIN RING IS COMPLETELY CLEAN DOWN TO BARE METAL.
2. FLEECE-BACKING MUST BE REMOVED FROM THE MEMBRANE SO THAT WATER CUT-OFF MASTIC IS IN DIRECT CONTACT.
3. THE HOLE IN THE MEMBRANE SHALL EXCEED THE DIAMETER OF THE DRAIN PIPE, BUT SHALL BE NO LESS THAN 1/2" (1.5cm) FROM THE ATTACHMENT POINTS OF THE DRAIN CLAMPING RING.
4. ALL BOLTS OR CLAMPS MUST BE IN PLACE TO PROVIDE CONSTANT COMPRESSION ON WATER CUT-OFF MASTIC.
5. ROOF DRAIN SIZE AND NUMBER OF DRAINS SHALL BE IN ACCORDANCE WITH THE LOCAL CODES.

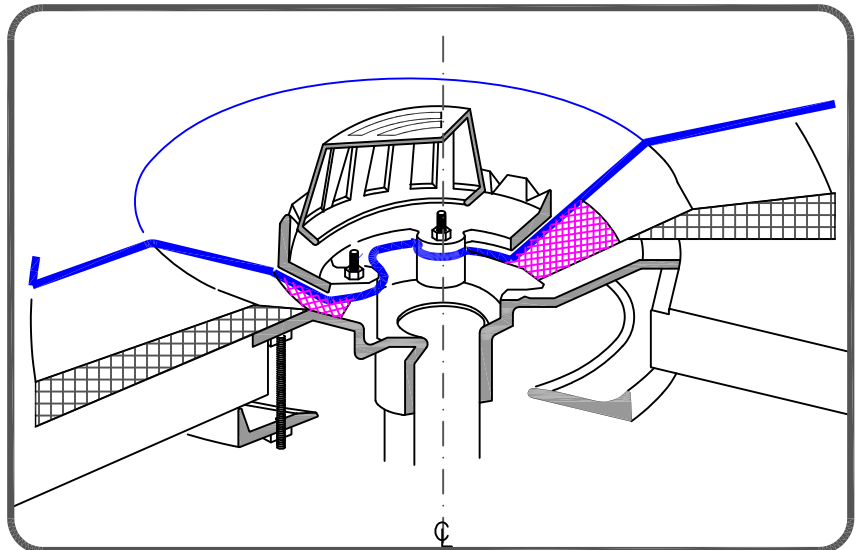
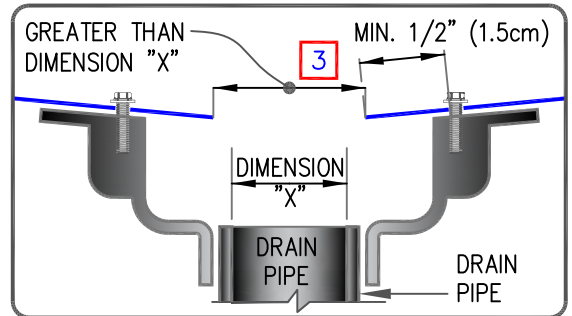

| | | |
|--|-------------------------------------|-----------------------------|
| | ROOF DRAIN WITH CONTINUOUS MEMBRANE | DETAIL NO. AFX-6A |
| | MAXIMUM WARRANTY: 30 YEARS | |

CAUTION

EPDM MEMBRANE SPLICES SHALL INCORPORATE 6" (15cm) WIDE FIELD APPLIED SecurTAPE FOR PROJECTS WITH 20 AND 25-YEAR WARRANTIES.

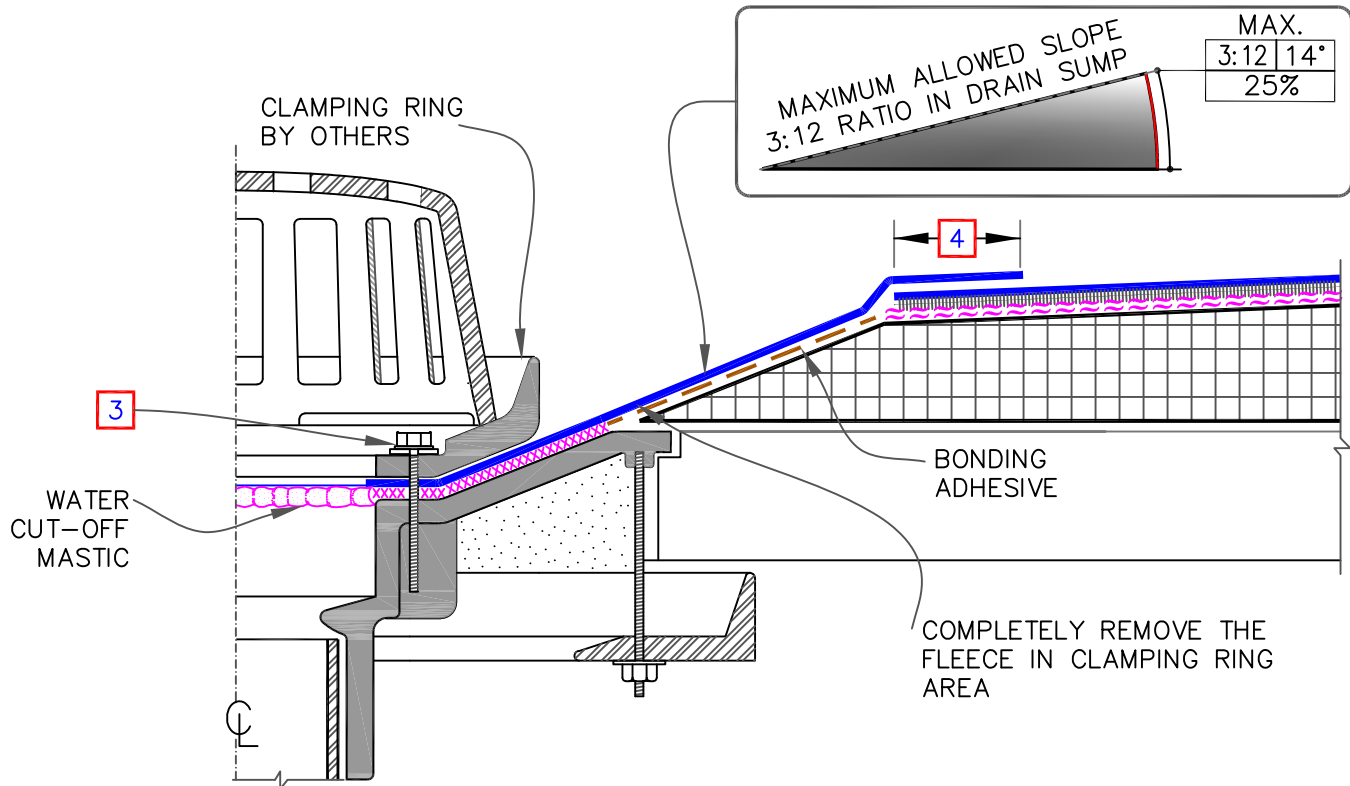

NOTES:

1. REMOVE EXISTING LEAD, FLASHING MATERIAL & ENSURE THE DRAIN RING IS COMPLETELY CLEAN DOWN TO BARE METAL.
2. THE HOLE IN THE MEMBRANE SHALL EXCEED THE DIAMETER OF THE DRAIN PIPE, BUT SHALL BE NO LESS THAN 1/2" (1.5cm) FROM THE ATTACHMENT POINTS OF THE DRAIN CLAMPING RING.
3. ALL BOLTS OR CLAMPS MUST BE IN PLACE TO PROVIDE CONSTANT COMPRESSION ON WATER CUT-OFF MASTIC.
4. SPLICES SHALL BE COMPLETED USING MIN. 3" (7.5cm) WIDE SecurTAPE/ PRIMER WITH EPDM MEMBRANE AND MINIMUM 1-1/2" (4cm) HOT AIR WELD WITH TPO/KEE HP.
5. FIELD SPLICES MUST BE LOCATED AT LEAST 6 INCHES (15cm) OUTSIDE THE DRAIN SUMP.
6. APPROXIMATELY 1/8" (0.5cm) DIAMETER BEAD OF CUT-EDGE SEALANT IS REQUIRED ON CUT EDGES OF REINFORCED TPO MEMBRANE.
7. ROOF DRAIN SIZE AND NUMBER OF DRAINS SHALL BE IN ACCORDANCE WITH THE LOCAL CODES.

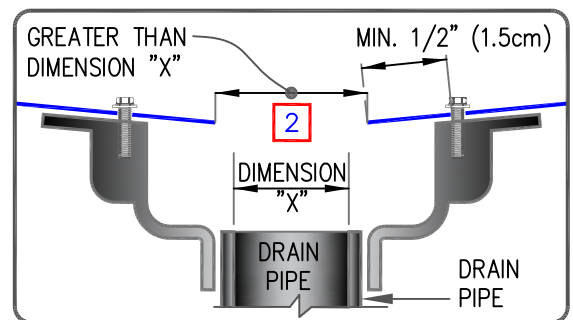

ROOF DRAIN WITH SEPARATE TARGET SPLICE

MAXIMUM WARRANTY: 30 YEARS



DETAIL NO.

AFX-6B

AFX ADHERED

EPDM

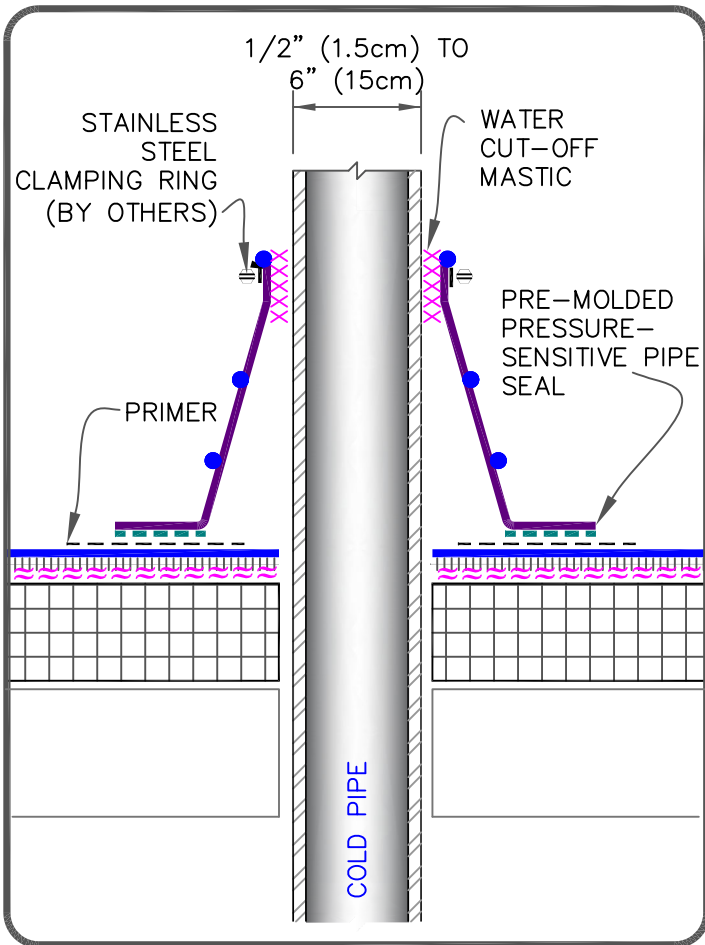

NOTES:

1. REMOVE ALL LEAD AND OTHER FLASHING BEFORE INSTALLING FIELD FABRICATED PIPE SEAL.
2. TEMPERATURE OF PIPE MUST NOT EXCEED 180°F (82°C).
3. APPLY EPDM PRIMER TO SPLICE AREA.
4. PRE-MOLDED PIPE FLASHING MUST HAVE INTACT RIB AT THE TOP EDGE REGARDLESS OF PIPE DIAMETER.
5. DECK FLANGES OF THE PRE-MOLDED PIPE SEAL SHALL NOT BE OVERLAPPED, CUT OR APPLIED OVER ANY ANGLE CHANGE.
6. WHEN A FIELD SPLICE INTERSECTS A PIPE SEAL, APPLY LAP SEALANT ALONG THE EDGE OF THE MEMBRANE SPLICE COVERING THE EXPOSED SPLICE TAPE 1/2" (1.5cm) IN EACH DIRECTION FROM THE SPLICE INTERSECTION & OVERLAY WITH A 6"X6" (15 X 15cm) T-JOINT COVER.

TPO

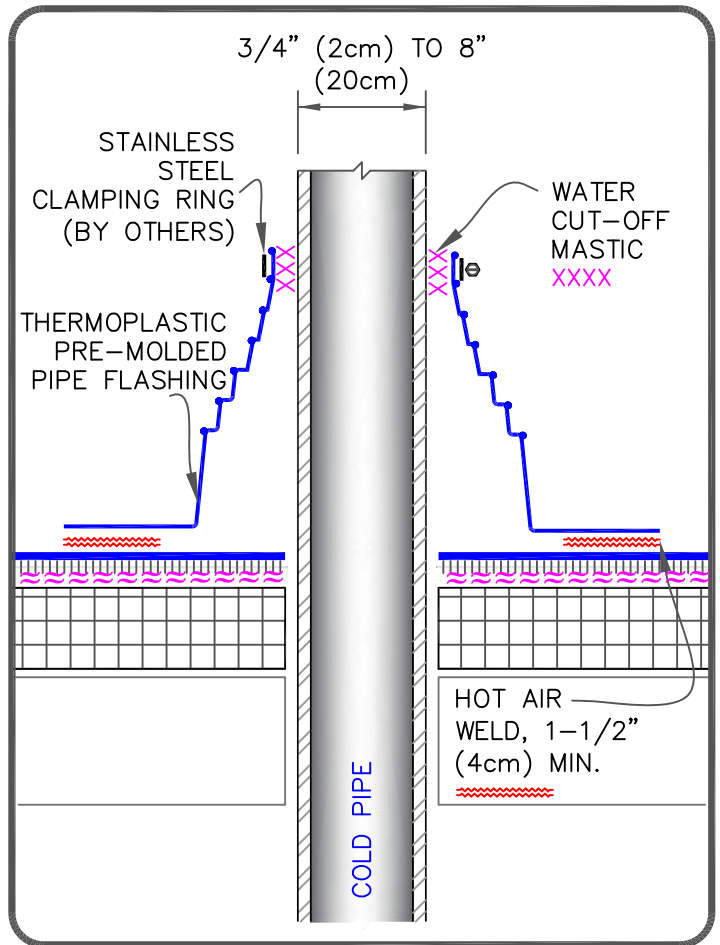

NOTES:

1. REMOVE ALL LEAD AND OTHER FLASHING BEFORE INSTALLING FIELD FABRICATED PIPE SEAL.
2. TEMPERATURE OF PIPE MUST NOT EXCEED 160°F (71°C).
3. PRE-MOLDED PIPE FLASHING MUST HAVE INTACT RIB AT THE TOP EDGE REGARDLESS OF PIPE DIAMETER.
4. DECK FLANGES OF THE PRE-MOLDED PIPE SEAL SHALL NOT BE OVERLAPPED, CUT OR APPLIED OVER ANY ANGLE CHANGE.



PRE-MOLDED PIPE SEALS

MAXIMUM WARRANTY: 30 YEARS



DETAIL NO.

AFX-8A

AFX ADHERED

CAUTION DETAIL NOT FOR USE ON 25-YEAR WARRANTY PROJECTS. ACCEPTABLE PIPE FLASHINGS SHALL CONFORM WITH **AFX-8A** DETAIL OR REFER TO THERMOSET/THERMOPLASTIC UNIVERSAL DETAILS.

EPDM

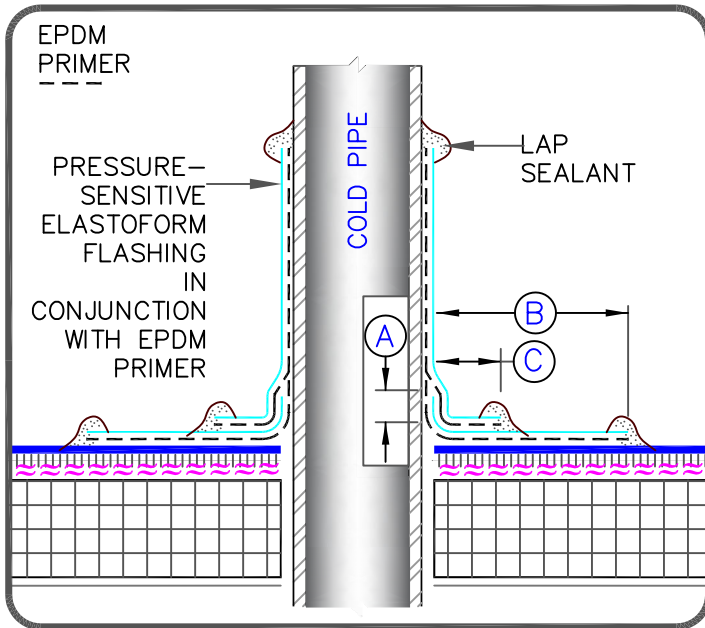

| DIMENSIONS | cm | |
|------------|-----|------|
| (A) 1/2" | 1.5 | MIN. |
| (B) 3" | 7.5 | MIN. |
| (C) 1" | 2.5 | MIN. |

NOTES:

1. REMOVE ALL LEAD AND OTHER FLASHING BEFORE INSTALLING FIELD-FABRICATED PIPE SEAL.
2. TEMPERATURE OF PIPE MUST NOT EXCEED 180°F (82°C).
3. PRIOR TO APPLYING PRESSURE-SENSITIVE ELASTOFORM FLASHING, APPLY EPDM PRIMER TO SPLICE AREAS.
4. MECHANICAL SECUREMENT IS REQUIRED AROUND ALL PIPES GREATER THAN 18" (46cm) IN DIAMETER.
5. IN COLDER TEMPERATURES A HEAT GUN MUST BE USED WHEN FORMING PRESSURE-SENSITIVE ELASTOFORM FLASHING.
6. REFER TO EPDM UNIVERSAL DETAILS FOR HOT STACK, STEEL TUBING & FLEXIBLE PIPE PENETRATIONS.

TPO/KEE HP

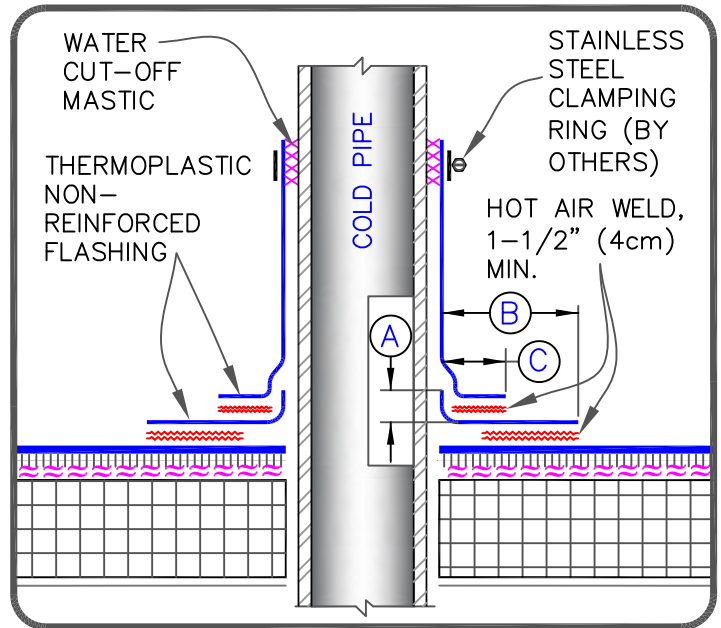

| DIMENSIONS | cm | |
|------------|-----|------|
| (A) 1/2" | 13 | MIN. |
| (B) 1-1/2" | 4 | TO |
| 2" | 5 | |
| (C) 1" | 2.5 | MIN. |

NOTES:

1. REMOVE ALL LEAD AND OTHER FLASHING BEFORE INSTALLING FIELD FABRICATED PIPE SEAL.
2. TEMPERATURE OF PIPE MUST NOT EXCEED 140°F (60°C) WHEN USING KEE HP AND 160°F (71°C) WHEN USING TPO FLASHING.
3. APPLY HEAT TO FLASHING AND FORM BY HAND PRIOR TO HOT AIR WELDING
4. MECHANICAL SECUREMENT IS REQUIRED AROUND ALL PIPES GREATER THAN 18" (46cm) IN DIAMETER.
5. REFER TO THERMOPLASTIC UNIVERSAL DETAILS FOR HOT STACK, STEEL TUBING & FLEXIBLE PIPE PENETRATIONS.

| | | | |
|--|--------------------------------|--|------------|
| | FIELD FABRICATED PIPE FLASHING | | DETAIL NO. |
| | MAXIMUM WARRANTY: 20 YEARS | | AFX-8B |

9A MECHANICAL TERMINATION WITH COUNTER FLASHING

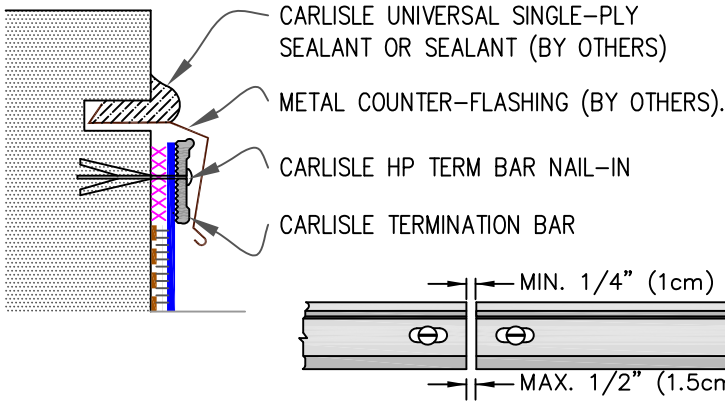

- NOTES:
1. APPLY ON HARD SMOOTH SURFACE ONLY; NOT FOR USE ON EXPOSED WOOD.
 2. DO NOT WRAP TERMINATION BAR AROUND CORNERS.
 3. FLEECE-BACKING MUST BE REMOVED FROM THE MEMBRANE SO THAT WATER CUT-OFF MASTIC IS IN DIRECT CONTACT.
 4. DETAIL REQUIRED FOR USE ON WARRANTY PROJECTS EXCEEDING 20-YEARS. MAY BE USED FOR ANY PROJECT REGARDLESS OF WARRANTY.
 5. DETAIL 9E MUST BE USED AT VERTICAL JOINTS IN PANEL WALLS.

9B SHEET METAL COPING

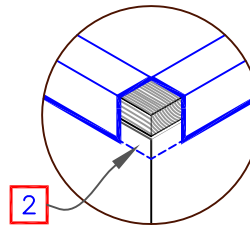
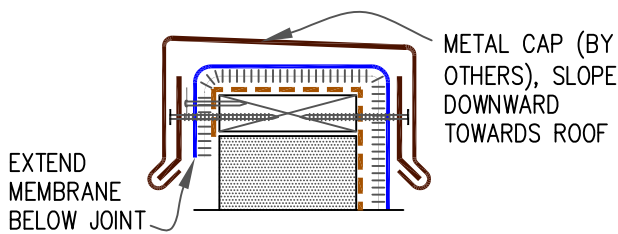

- NOTES:
1. FOR CARLISLE SecurEdge COPING, REFER TO INSTALLATION INSTRUCTIONS PUBLISHED SEPARATELY.
 2. MEMBRANE MUST BE EXTENDED TO CORNERS TO PROVIDE COMPLETE COVERAGE OF THE TOP WALL SURFACE.

9C COUNTER FLASHING TERMINATION

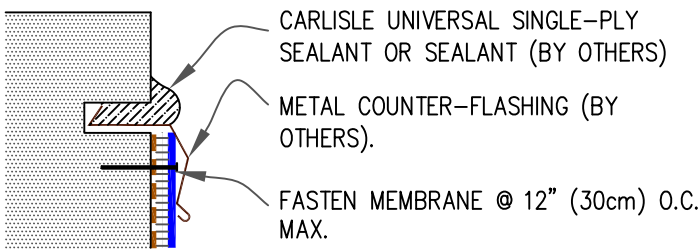

- NOTES:
1. WHEN MECHANICAL FASTENERS ARE USED TO PENETRATE THE METAL COUNTER-FLASHING, USE EPDM WASHERS, APPLY WATER CUT-OFF MASTIC UNDER THE COUNTER-FLASHING OR CAULK THE FASTENER HEADS.
 2. DETAIL NOT FOR USE ON WARRANTY PROJECTS EXCEEDING 10-YEARS.

9D MECHANICAL TERMINATION

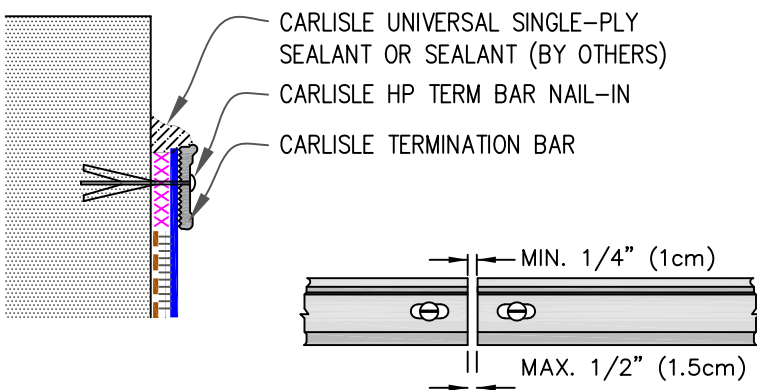

- NOTES:
1. APPLY ON HARD SMOOTH SURFACE ONLY; NOT FOR USE ON EXPOSED WOOD.
 2. DO NOT WRAP TERMINATION BAR AROUND CORNERS.
 3. FLEECE-BACKING MUST BE REMOVED FROM THE MEMBRANE SO THAT WATER CUT-OFF MASTIC IS IN DIRECT CONTACT.
 4. DETAIL NOT FOR USE ON WARRANTY PROJECTS EXCEEDING 20-YEARS.
 5. DETAIL 9E MUST BE USED AT VERTICAL JOINTS IN PANEL WALLS.

--- BONDING ADHESIVE, TYPE III OR IV ASPHALT OR COLD APPLIED ADHESIVE

xxxxxxx

CARLISLE WATER CUT-OFF MASTIC MUST BE UNDER COMPRESSION



MEMBRANE TERMINATIONS
PAGE 1 OF 2

MAXIMUM WARRANTY: 30 YEARS



DETAIL NO.

AFX-9

AFX ADHERED

9E MECHANICAL TERMINATION AT VERTICAL JOINTS

NOTES:

1. THIS DETAIL MUST BE USED FOR ANY PROJECT REGARDLESS OF WARRANTY.
2. CONTINUOUS COUNTER FLASHING REQUIRED FOR WARRANTY PROJECTS EXCEEDING 20-YEARS.
3. VERTICAL JOINTS IN THE PRE-CAST PANEL AS WELL AS ALL GAPS AT THE JUNCTION OF THE TILT-UP PANEL AND ROOF DECK MUST BE FULLY SEALED TO PREVENT AIR INFILTRATION.
4. APPLY ON HARD SMOOTH SURFACE ONLY.
5. THIS DETAIL MUST BE USED FOR ANY PROJECT REGARDLESS OF WARRANTY.

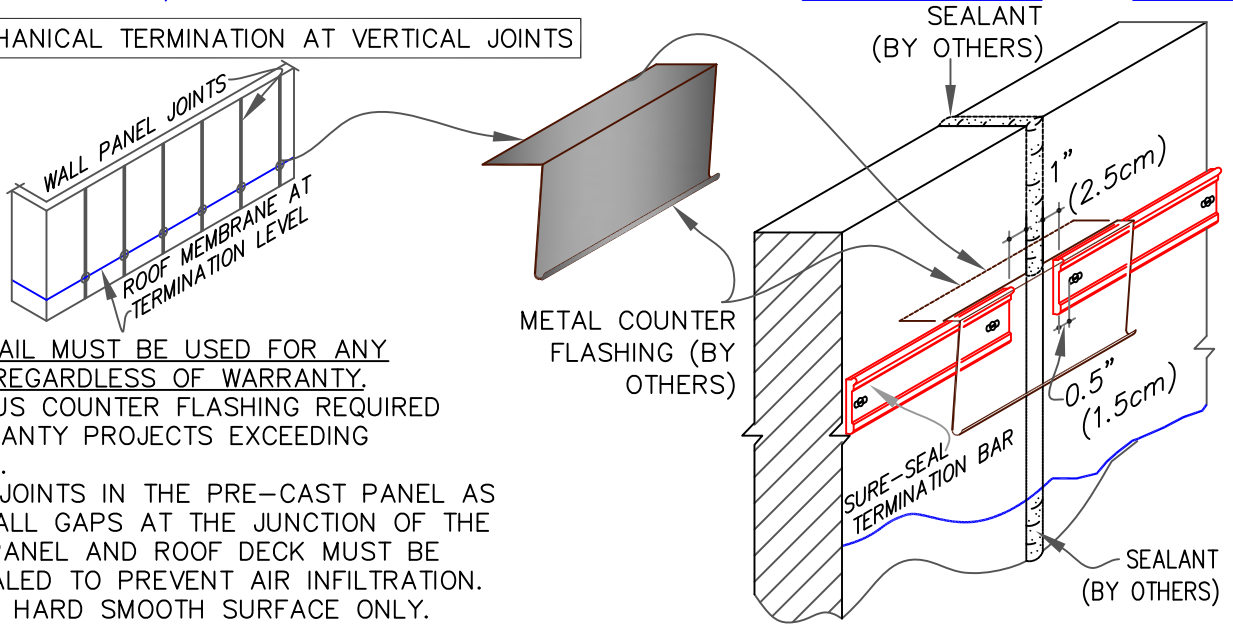

9F SecurEDGE COPING

- COPING
- 20 GA. GALVANIZED ANCHOR CLIPS @ 6 FEET (183cm) O.C.
- CONCEALED SPLICE PLATE AT EACH JOINT OF COPING
- HEX-HEAD FASTENERS

SecurEdge 200 & 300

NOTES:

1. MEMBRANE MUST BE EXTENDED AT CORNERS TO PROVIDE COMPLETE COVERAGE OF THE TOP WALL SURFACE. REFER TO [DETAIL U-9B](#).
2. REFER TO [SecurEdge COPING INSTALLATION INSTRUCTION MANUAL](#) FOR STEP-BY-STEP INSTRUCTION PROCEDURES.

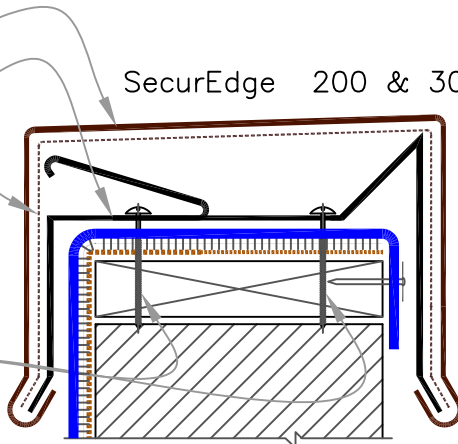

9G COPING STONE TERMINATION

SEE INSET ON RIGHT

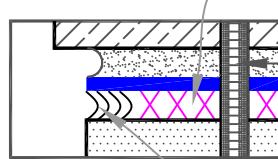
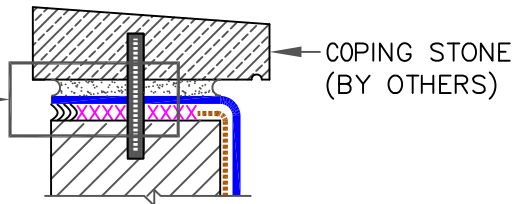

----- BONDING ADHESIVE, TYPE III OR IV ASPHALT OR COLD APPLIED ADHESIVE

xxxxxxx

CARLISLE WATER CUT-OFF MASTIC MUST BE UNDER COMPRESSION



MEMBRANE TERMINATIONS
PAGE 2 OF 2

MAXIMUM WARRANTY: 30 YEARS



DETAIL NO.

AFX-9

AFX ADHERED

CAUTION

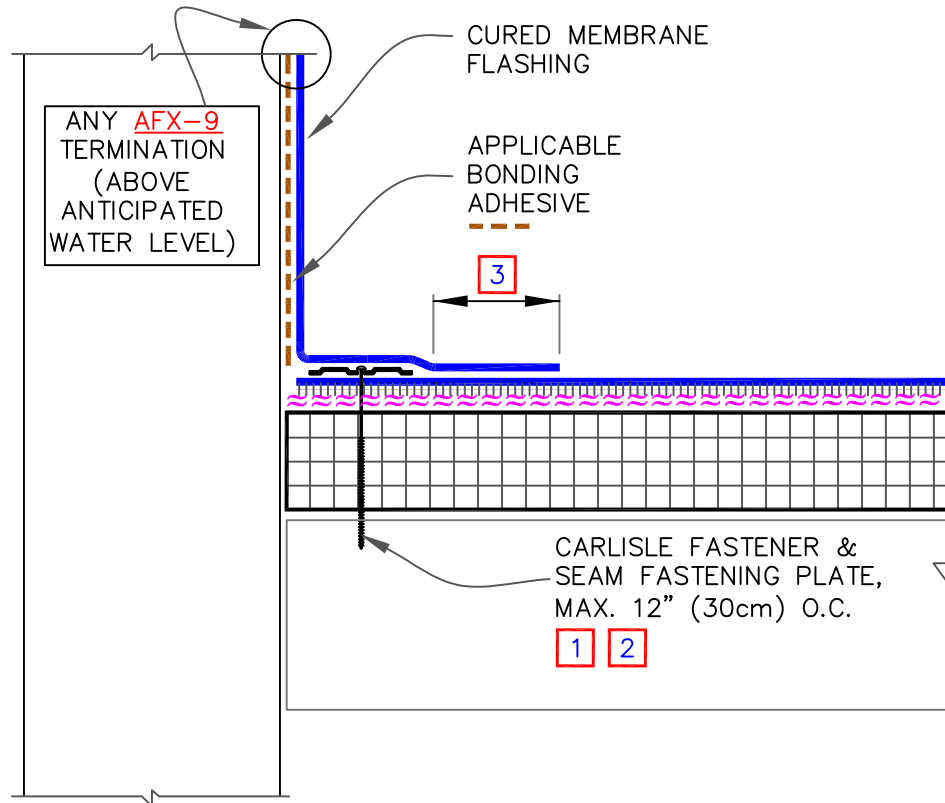

EPDM MEMBRANE SPLICES SHALL INCORPORATE 6" (15cm) WIDE FIELD APPLIED SecurTAPE FOR PROJECTS WITH 20 AND 25-YEAR WARRANTIES.



NOTES:

- MECHANICAL SECUREMENT IS NOT NECESSARY WHEN AFX MEMBRANE IS ADHERED WITH HOT ASPHALT.
- IN A CASE WHERE FASTENERS MUST BE FASTENED INTO THE VERTICAL SUBSTRATE, CARE MUST BE TAKEN TO CREASE THE MEMBRANE TIGHTLY INTO THE ANGLE CHANGE. PLACING THE PLATES TIGHT INTO THE ANGLE CHANGE WILL HELP HOLD THE MEMBRANE IN THE PROPER POSITION.
- SPLICES SHALL BE COMPLETED USING MINIMUM 3" (7.5cm) WIDE SecurTAPE/ PRIMER WITH EPDM MEMBRANE AND MINIMUM 1-1/2" (4cm) HOT AIR WELD WITH TPO.
- WHEN USING 60 OR 80-MIL REINFORCED TPO MEMBRANE FLASHING, APPLY A 4-1/2" (11cm) DIAMETER TPO "T-JOINT" COVER AT ALL FIELD SPlice INTERSECTIONS.

ALL EPDM SPlice INTERSECTIONS MUST BE OVERLAID WITH A PRESSURE-SENSITIVE T-JOINT COVER. PRIOR TO DOING SO, APPLY LAP SEALANT ALONG THE EDGE OF THE MEMBRANE SPlice (UNDER THE 6"x6" (15cm X 15cm) T-JOINT COVER) COVERING THE EXPOSED SPlice TAPE 2" (5cm) IN EACH DIRECTION FROM THE SPlice INTERSECTION. PROJECTS WITH 25-YEAR WARRANTIES MUST BE OVERLAID WITH TWO LAYERS OF PRESSURE-SENSITIVE ELASTOFORM FLASHING. THE BOTTOM LAYER SHALL BE 6"x6" (15cm X 15cm) COVERED WITH A 12"x12" TOP LAYER (30cm X 30cm). BOTH LAYERS SHALL BE CENTERED OVER THE SPlice INTERSECTION AND SEALED WITH CONTINUOUS LAP SEALANT, REFER TO AFX-2 DETAILS.

| | | |
|--|--|--|
|  | PARAPET/CURB WITH SEPARATE MEMBRANE FLASHING |  DETAIL NO. AFX-12A |
| | MAXIMUM WARRANTY: 30 YEARS | |

CAUTION

EPDM MEMBRANE SPLICES SHALL INCORPORATE 6" (15cm) WIDE FIELD APPLIED SecurTAPE FOR PROJECTS WITH 20 AND 25-YEAR WARRANTIES.

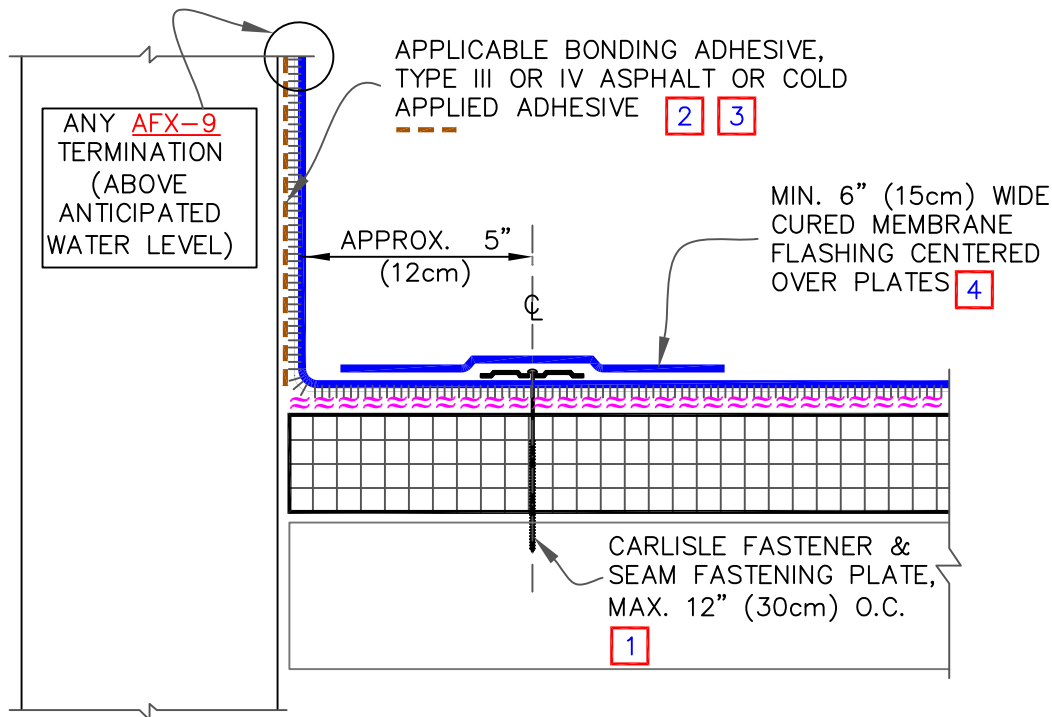

NOTES:

1. MECHANICAL SECUREMENT IS NOT NECESSARY WHEN AFX MEMBRANE IS ADHERED WITH HOT ASPHALT.
2. WHEN APPLYING BONDING ADHESIVE TO AFX MEMBRANE, APPLY A COAT TO THE FLEECE SIDE OF THE MEMBRANE AND ALLOW TO DRY. ONCE DRY, APPLY A SECOND COAT OF BONDING ADHESIVE TO THE FLEECE SIDE OF THE MEMBRANE AND TO THE SUBSTRATE, ALLOW TO FLASH OFF AND MATE THE TWO SURFACES TOGETHER.
3. WHEN APPLYING ASPHALT OR COLD APPLIED ADHESIVE TO A VERTICAL SUBSTRATE, CARE MUST BE TAKEN TO AVOID DRIPPING OR PUDDLING AT THE BASE OF A WALL. MAXIMUM FLASHING HEIGHT SHALL NOT EXCEED 18" (46cm).
4. WHEN USING EPDM AFX MEMBRANE, MINIMUM 6" (15cm) WIDE PRESSURE-SENSITIVE CURED COVER STRIP MUST BE CENTERED OVER THE MECHANICAL FASTENERS AND PLATES. WHEN USING TPO AFX MEMBRANE, MINIMUM 6" (15cm) WIDE REINFORCED TPO MEMBRANE FLASHING SHALL BE CENTERED OVER THE MECHANICAL FASTENERS AND PLATES AND HEAT WELDED ON ALL SIDES.



PARAPET/CURB WITH CONTINUOUS MEMBRANE FLASHING

MAXIMUM WARRANTY: 30 YEARS



DETAIL NO.

AFX-12B

AFX ADHERED

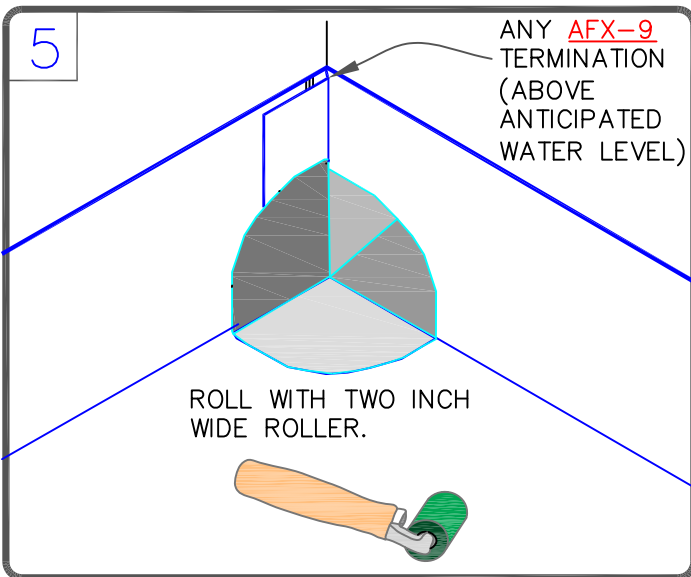
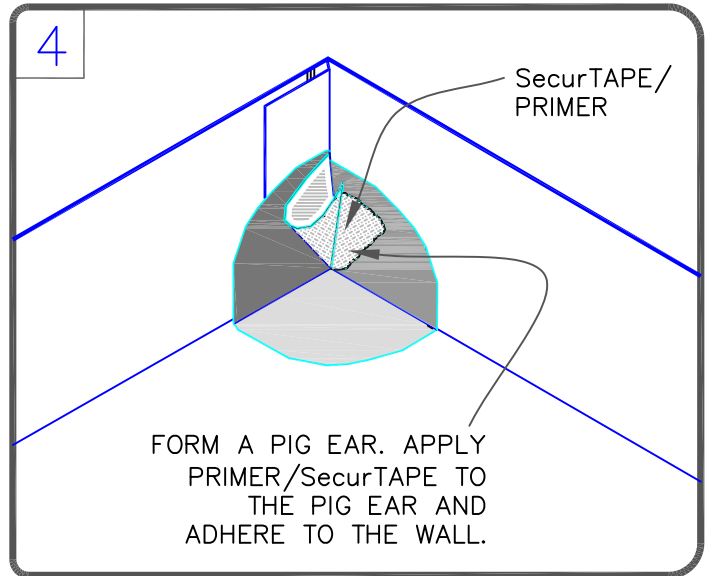
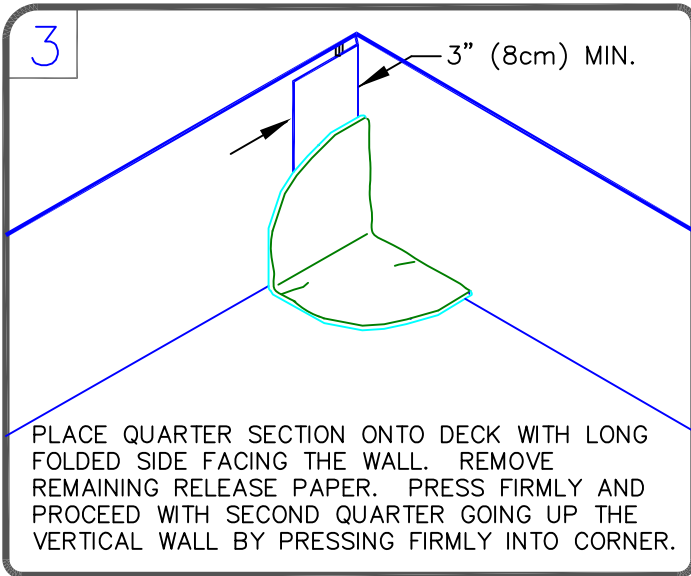
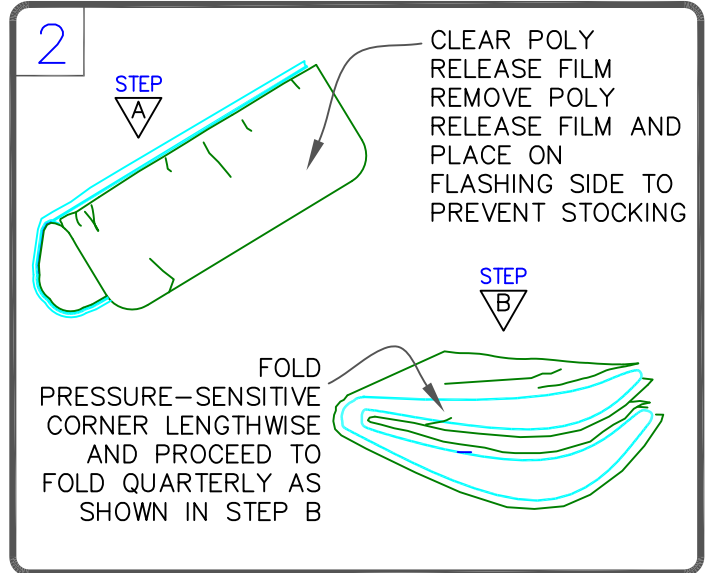
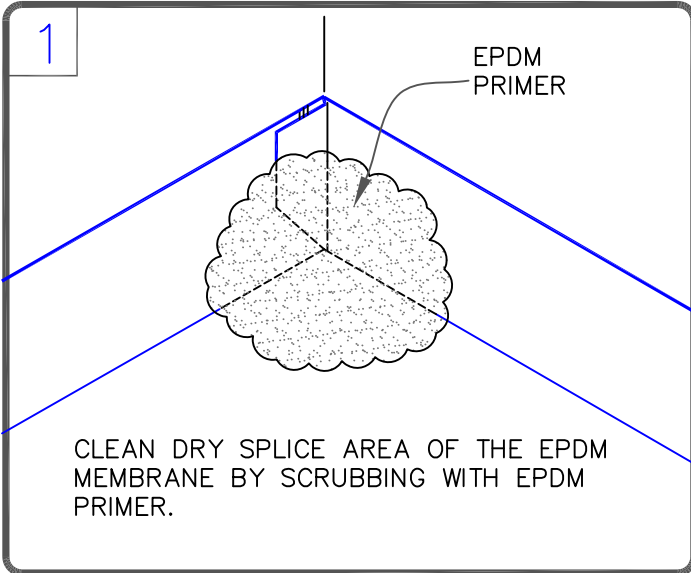

NOTES:

- FOR PROJECTS WITH 25 AND 30-YEAR WARRANTIES, ALL INSIDE CORNERS MUST BE OVERLAID WITH TWO LAYERS OF PRESSURE-SENSITIVE FLASHING. THE BOTTOM LAYER SHALL BE A 7"X9" (18cm X 23cm) PRESSURE-SENSITIVE PRE-CUT INSIDE/OUTSIDE CORNER OR A 6'X6" (15cm X 15cm) PRESSURE-SENSITIVE ELASTOFORM FLASHING PIECE COVERED WITH A 12"X12" TOP LAYER (30cm X 30cm) OF PRESSURE-SENSITIVE ELASTOFORM FLASHING. BOTH LAYERS SHALL BE CENTERED AND SEALED WITH CONTINUOUS LAP SEALANT.
- EPDM PRIMER MUST BE APPLIED TO ALL SPLICE AREAS AND FOR EACH LAYER OF PRESSURE-SENSITIVE FLASHING.



EPDM PRESSURE-SENSITIVE INSIDE CORNER

MAXIMUM WARRANTY: 30 YEARS



DETAIL NO.

AFX-15A

AFX ADHERED

1

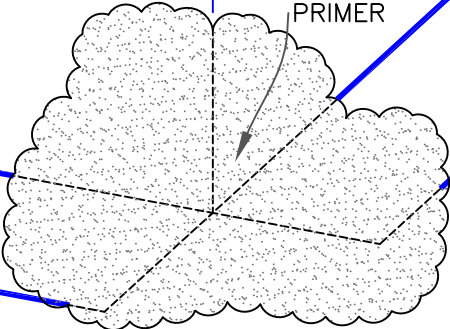

EPDM PRIMER

CLEAN THE DRY SPLICE AREA OF THE EPDM MEMBRANE BY SCRUBBING WITH EPDM PRIMER.

2

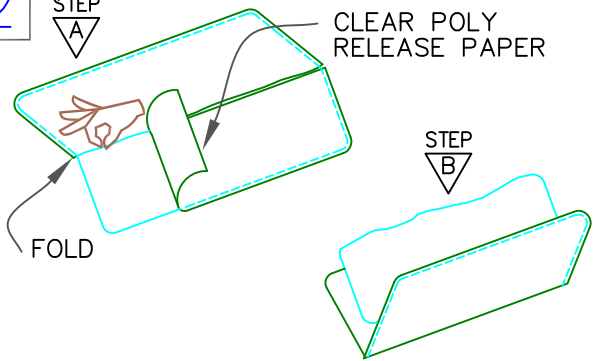

STEP A

CLEAR POLY RELEASE PAPER

FOLD

STEP B

PRIOR TO PLACEMENT OF SURE-SEAL CORNER, PEEL OFF THE BLUE POLY RELEASE FILM AND HEAT THE FLASHING SIDE WITH A HEAT GUN. RE-APPLY THE POLY LOOSELY. FOLD THE FLASHING IN HALF.

3

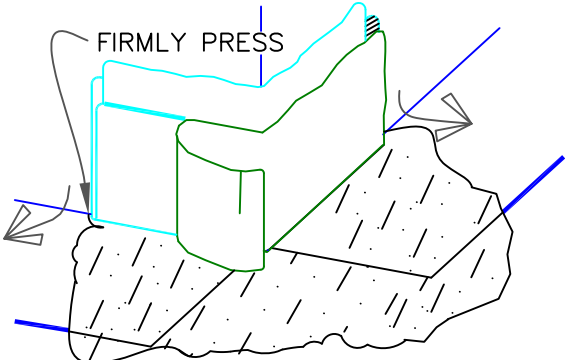

FIRMLY PRESS

PLACE SURE-SEAL INSIDE/OUTSIDE CORNER AS SHOWN AND REMOVE RELEASE PAPER. PRESS FOLDED FLASHING TIGHTLY INTO ANGLE CHANGE AND FIRMLY PRESS FLASHING AGAINST THE VERTICAL SURFACE.

4

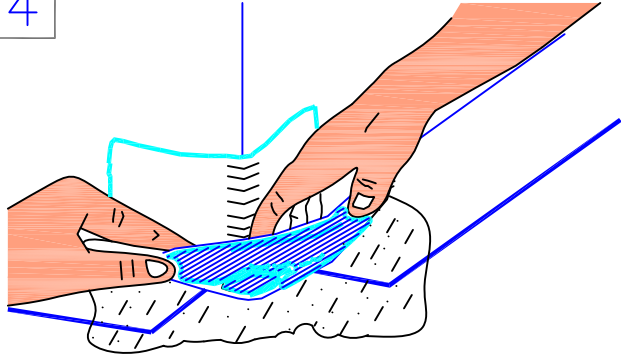

PLACE FOLDED FLASHING TIGHTLY INTO ANGLE CHANGE AND FIRMLY PRESS FLASHING ONTO THE DECK FLANGE BY PRESSING THE FLASHING AGAINST THE HORIZONTAL SURFACE.

5

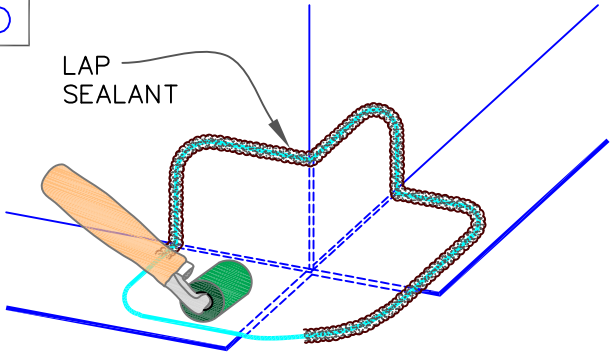



LAP SEALANT

ROLL WITH A TWO INCH WIDE ROLLER. PAY PARTICULAR ATTENTION TO THE STEP OFFS AND ANGLE CHANGE.

NOTE:

FOR PROJECTS WITH 25 AND 30-YEAR WARRANTIES OR WHEN USING 145-MIL MEMBRANE, REFER TO [THERMOSET DETAIL U-15H](#) FOR REQUIRED FLASHING ENHANCEMENTS.

| | | |
|--|--|--|
|  | EPDM PRESSURE-SENSITIVE OUTSIDE CORNER |  DETAIL NO. AFX-15B |
| | MAXIMUM WARRANTY: 30 YEARS | |

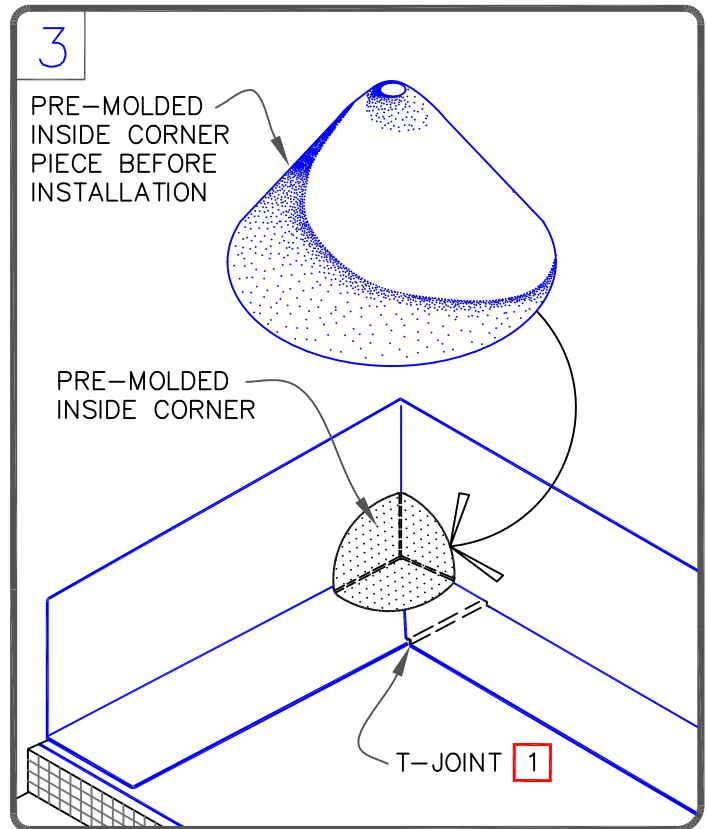
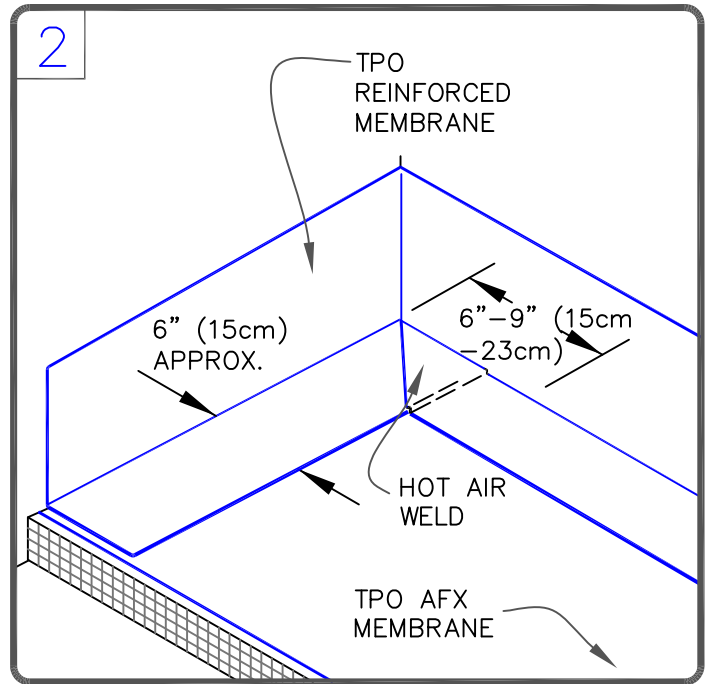
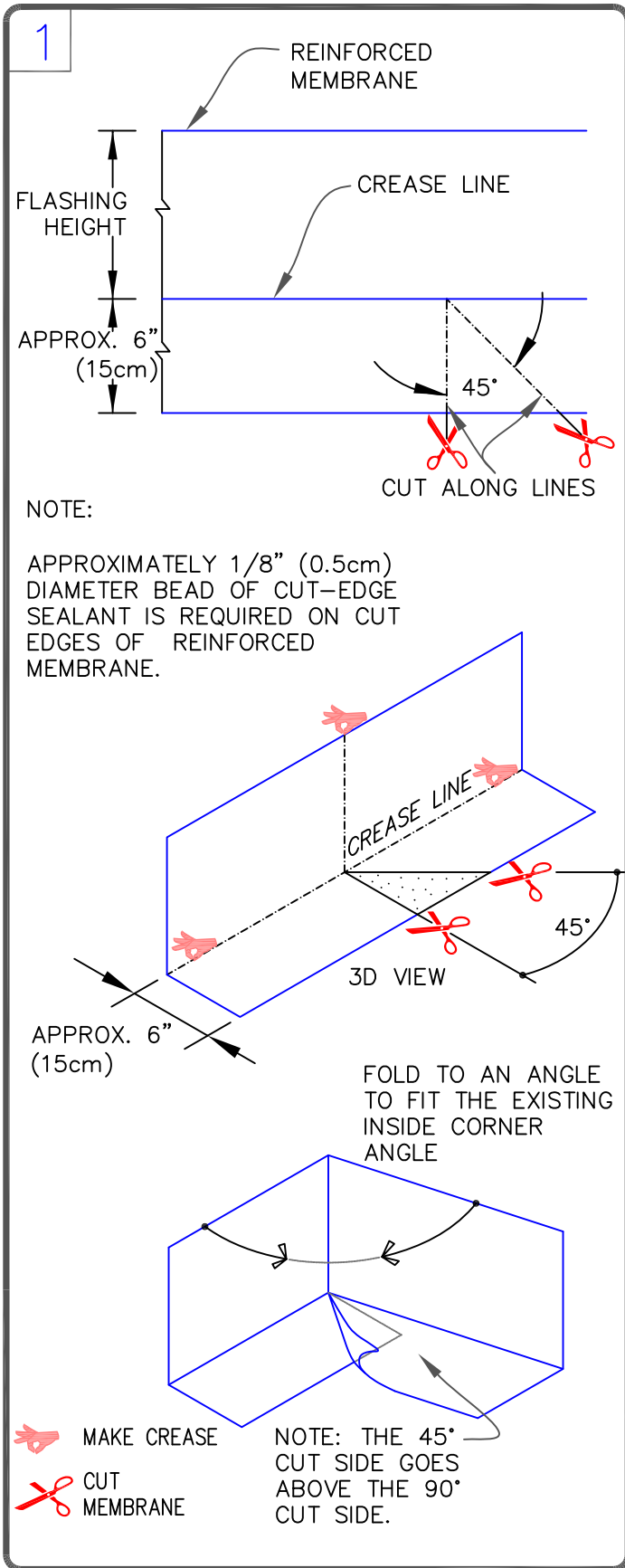

NOTES:

1. WHEN USING 60 OR 80-MIL MEMBRANE, APPLY A 4-1/2" (11cm) DIAMETER "T-JOINT" COVER AT ALL FIELD SPLICE INTERSECTIONS.



TPO PRE-MOLDED INSIDE CORNER

MAXIMUM WARRANTY: 30 YEARS



DETAIL NO.

AFX-15C

AFX ADHERED

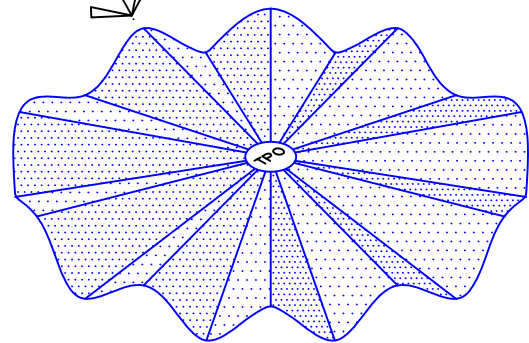
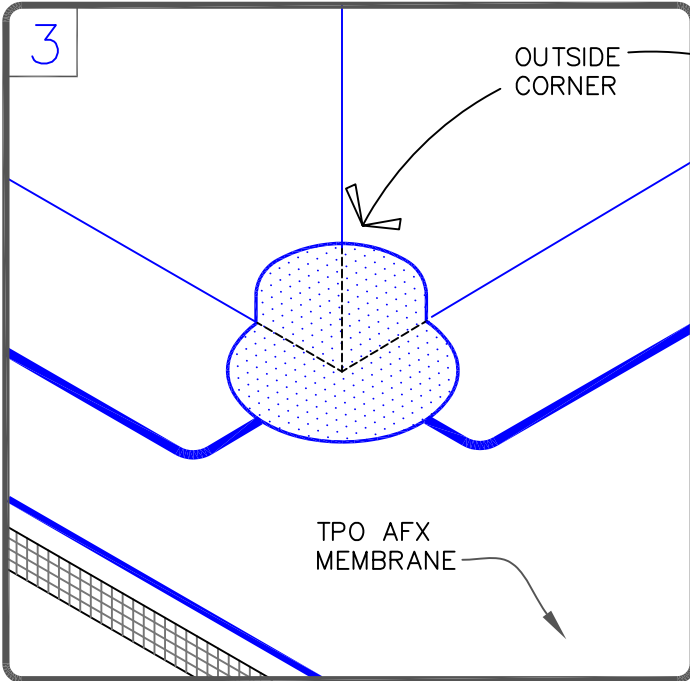
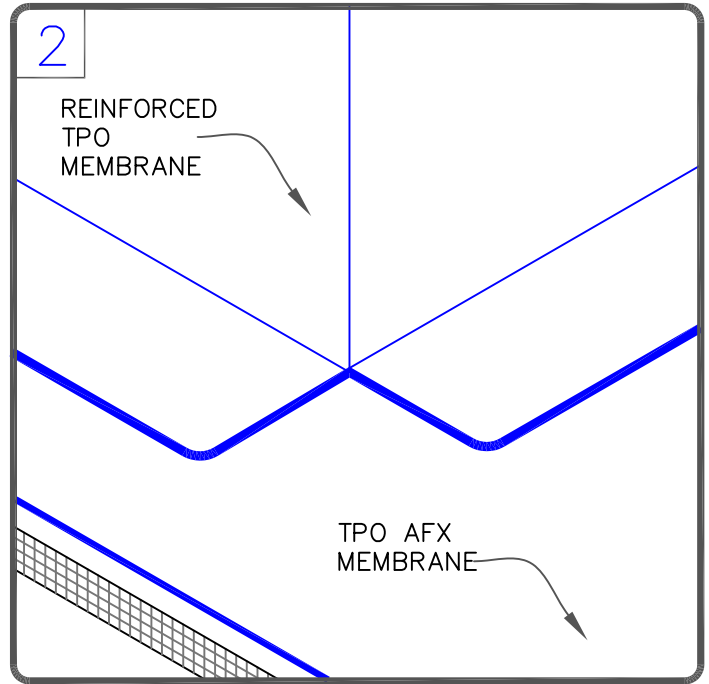
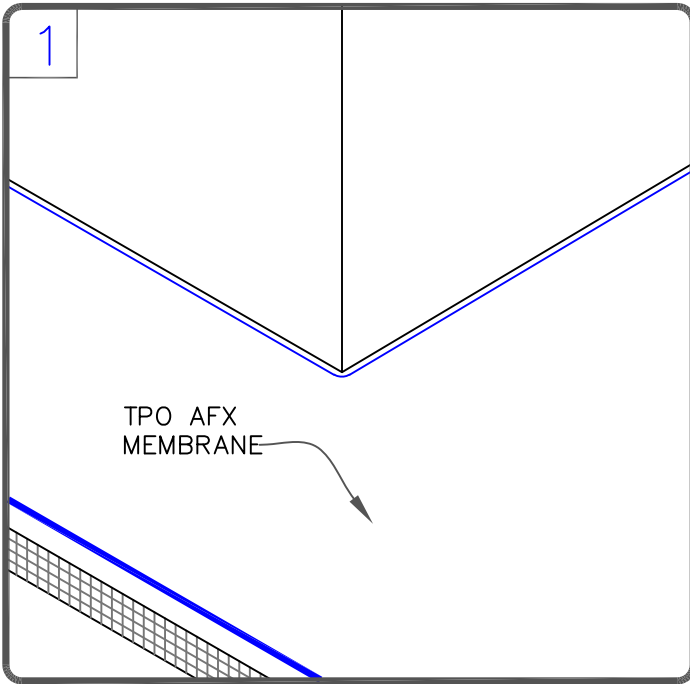

NOTE:

APPROXIMATELY 1/8" (0.5cm) DIAMETER BEAD OF CUT-EDGE SEALANT IS REQUIRED ON CUT EDGES OF REINFORCED TPO MEMBRANE.

| | | | |
|--|-------------------------------|-------------|------------|
| | TPO PRE-MOLDED OUTSIDE CORNER | | DETAIL NO. |
| | MAXIMUM WARRANTY: 30 YEARS | | AFX-15D |
| | | AFX ADHERED | |

CAUTION

POURABLE SEALER POCKETS MUST BE USED IN CONJUNCTION WITH RAIN HOODS AND AN EXTRA LAYER OF PRESSURE SENSITIVE ELASTOFORM FLASHING [EXTENDING 3" (7.5cm) BEYOND THE BASE LAYER OF FLASHING] FOR PROJECTS WITH 25-YEAR WARRANTIES.

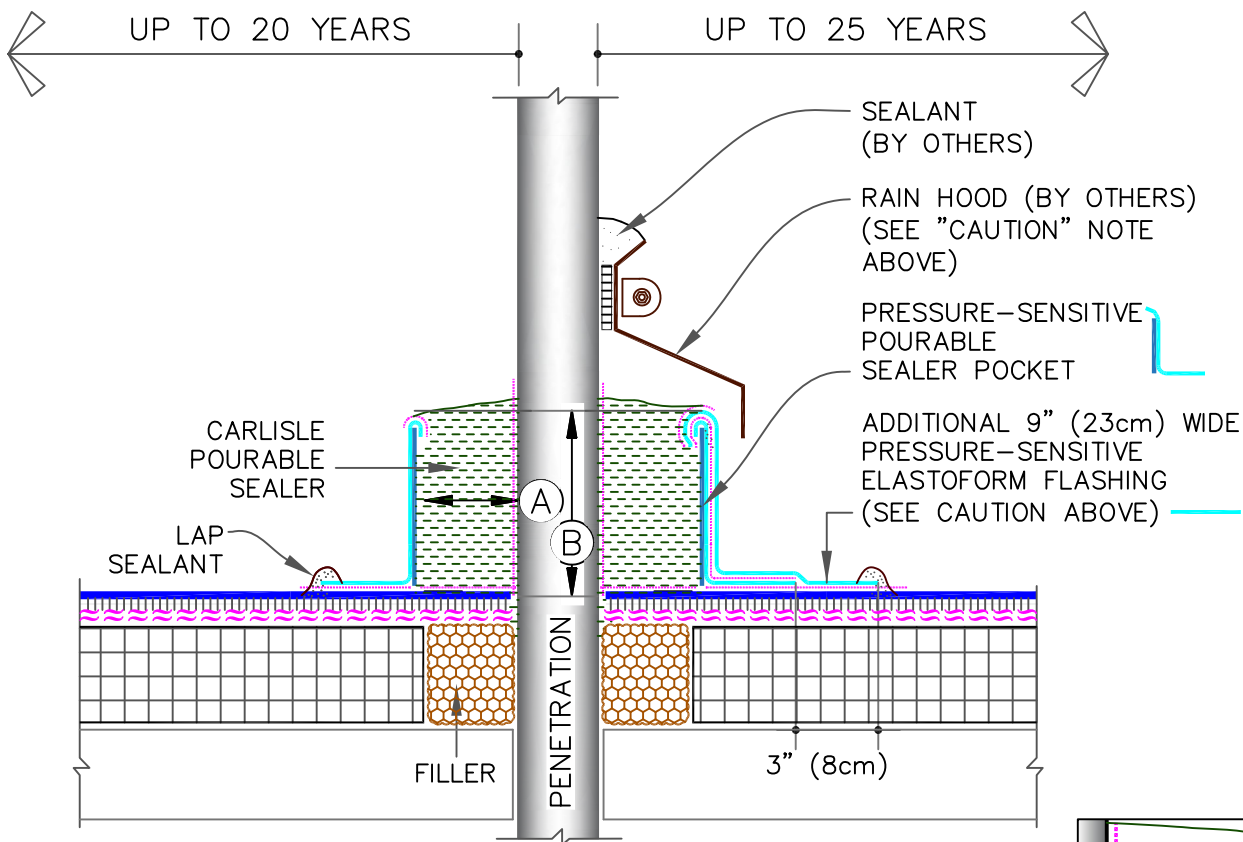

NOTES:

1. THE MAXIMUM ALLOWABLE SURFACE TEMPERATURE OF THE PENETRATION SHALL NOT EXCEED 180° F (82° C).
2. ALL DEBRIS (PAINT, RUST, LEAD, OTHER FLASHINGS, ETC.) MUST BE REMOVED FROM THE PENETRATION.
3. PENETRATIONS, MEMBRANE, FLASHING AND METAL (INSIDE POCKET) MUST BE PRIMED WITH EPDM PRIMER PRIOR TO APPLYING POURABLE SEALER. DO NOT PRIME THE BLUE PLASTIC SUPPORT STRIP.
4. POURABLE SEALER MUST COMPLETELY FILL POURABLE SEALER POCKET TO PREVENT PONDING OF WATER.
5. POURABLE SEALER MUST CONTACT PRIMED PRESSURE-SENSITIVE ELASTOFORM FLASHING AND DECK MEMBRANE.
6. SECUREMENT IS REQUIRED FOR POURABLE SEALER POCKETS WHICH ARE GREATER THAN 18" (46cm) IN DIAMETER. REFER TO SPECIFICATIONS.
7. PIPE CLUSTERS MUST HAVE MINIMUM 1" (2.5cm) CLEARANCE BETWEEN PENETRATIONS.
8. WHEN COLD APPLIED ADHESIVE IS USED TO ADHERE THE AFX MEMBRANE TO AN APPROVED SUBSTRATE, SECUREMENT IS REQUIRED FOR POURABLE SEALER POCKETS WHICH ARE GREATER THAN 18" (46cm) IN DIAMETER.

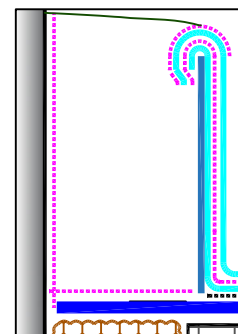

MANDATORY EPDM PRIMER AT ALL INTERFACES OF POURABLE SEALER EXCEPT BLUE PLASTIC SUPPORT STRIP

| DIMENSIONS | cm | | |
|------------|----|-----|------|
| (A) | 1" | 2.5 | MIN. |
| (B) | 2" | 5 | MIN. |



EPDM PRESSURE-SENSITIVE POURABLE SEALER POCKET

MAXIMUM WARRANTY: 30 YEARS



DETAIL NO.

AFX-16A

AFX ADHERED

CAUTION MOLDED SEALANT POCKETS MUST BE USED IN CONJUNCTION WITH RAIN HOODS FOR PROJECTS WITH 25 YEAR WARRANTIES.

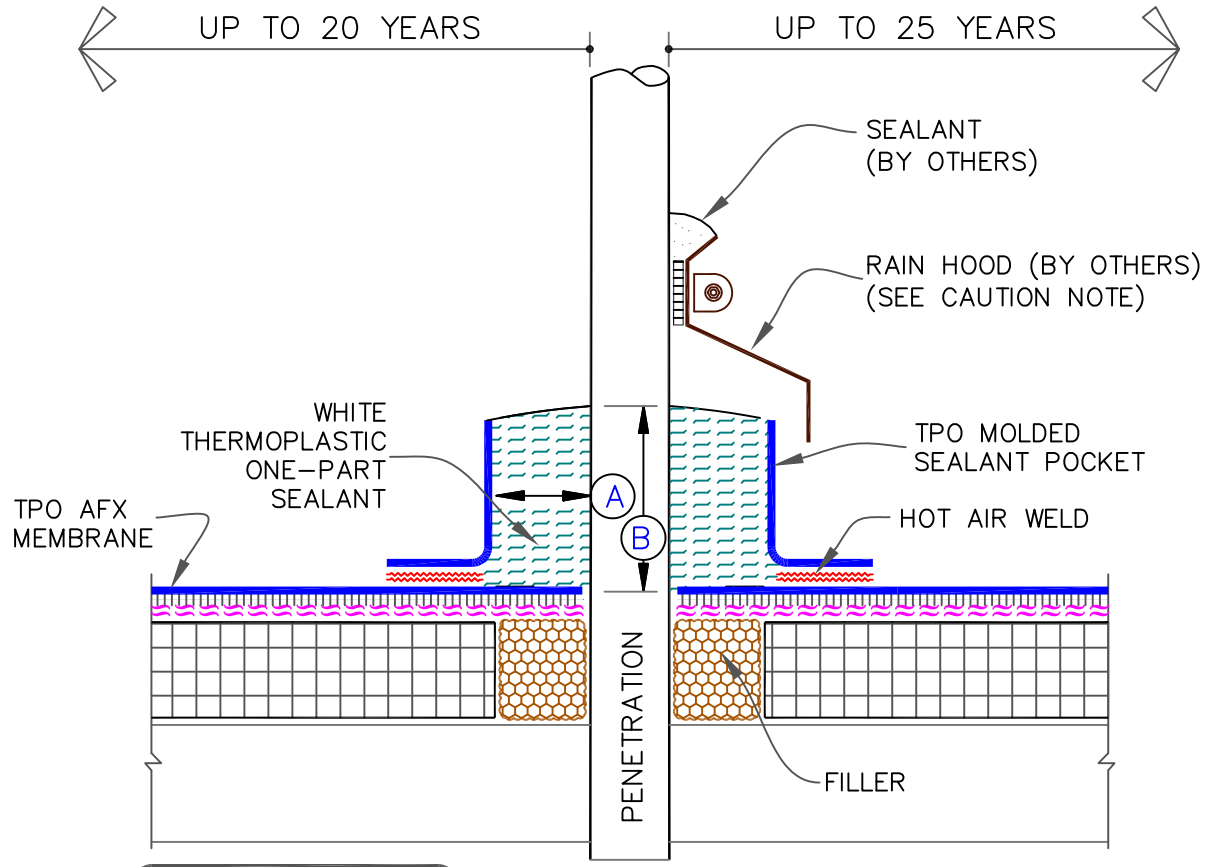

| DIMENSIONS | cm | | |
|------------|----|-----|------|
| (A) | 1" | 2.5 | MIN. |
| (B) | 2" | 5 | MIN. |

NOTES:

1. TEMPERATURE OF PIPE MUST NOT EXCEED 160°F (71°C).
2. APPLY A THIN COAT OF TPO PRIMER TO THE INSIDE AND AROUND THE TOP RIM OF THE POCKET, TO THE DECK MEMBRANE ENCLOSED BY THE POCKET AND TO THE PENETRATION USING A SMALL PAINT BRUSH.
3. ONE-PART SEALANT MUST COMPLETELY FILL MOLDED SEALANT POCKET TO PREVENT PONDING OF WATER.
4. PIPE CLUSTERS MUST HAVE MINIMUM 1" (2.5mm) CLEARANCE BETWEEN PENETRATIONS.

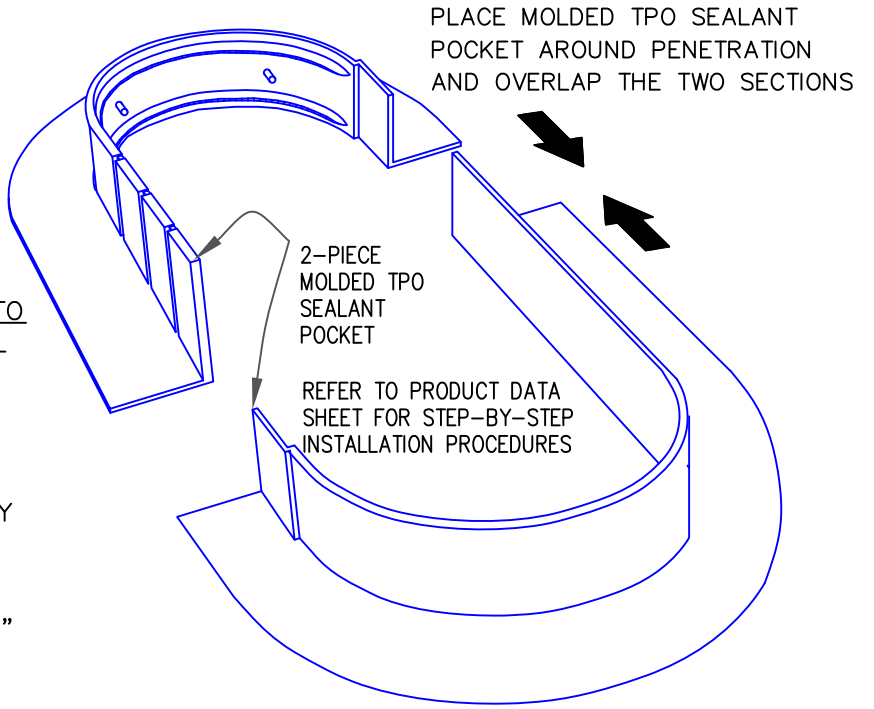

| | | | |
|--|----------------------------|-------------|------------|
| | TPO MOLDED SEALANT POCKET | | DETAIL NO. |
| | MAXIMUM WARRANTY: 30 YEARS | | AFX-16B |
| | | AFX ADHERED | |

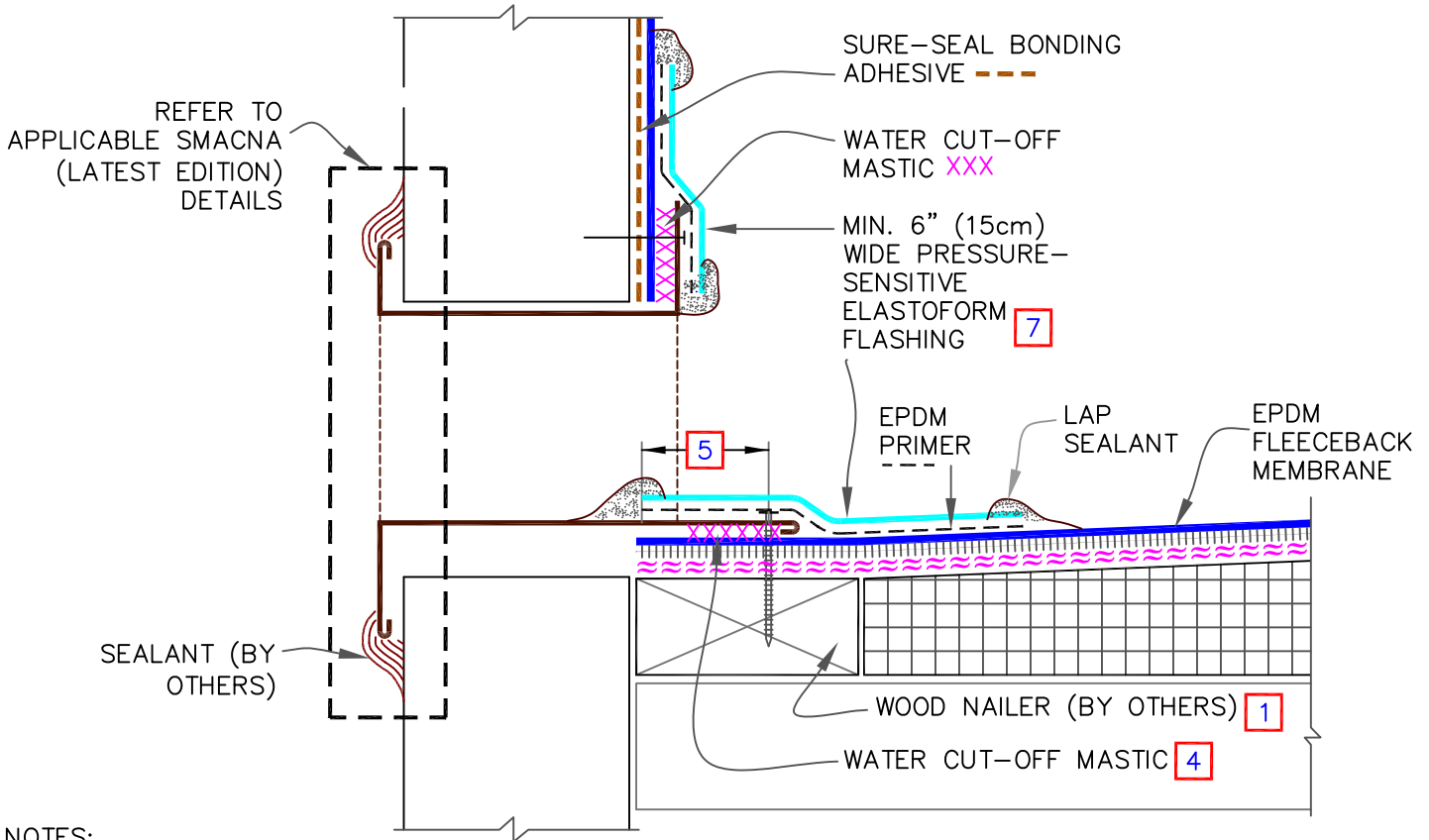

NOTES:

1. WOOD NAILERS ARE INSTALLED ONLY AT SCUPPERS TO SECURE METAL SLEEVE AND MUST EXTEND PAST THE WIDTH OF METAL SLEEVE FLANGE.
2. INSTALL WALL FLASHING PRIOR TO SCUPPER INSTALLATION.
3. METAL SCUPPER BOX MUST HAVE CONTINUOUS FLANGES WITH ROUNDED CORNERS. SOLDER ALL SCUPPER SEAMS WATER-TIGHT.
4. WATER CUT-OFF MASTIC UNDER SCUPPER FLANGE MUST BE UNDER CONSTANT COMPRESSION.
5. SCUPPER FLANGES MUST BE TOTALLY COVERED BY PRESSURE-SENSITIVE ELASTOFORM FLASHING WITH MINIMUM 2" (5cm) COVERAGE PAST NAIL HEADS.
6. TO REMOVE FINISHING OILS, SCRUB METAL FLANGE WITH WEATHERED MEMBRANE CLEANER; ALLOW TO DRY PRIOR TO APPLYING EPDM PRIMER.
7. APPLY EPDM PRIMER TO METAL FLANGE AND MEMBRANE SURFACE PRIOR TO INSTALLING PRESSURE-SENSITIVE ELASTOFORM FLASHING.

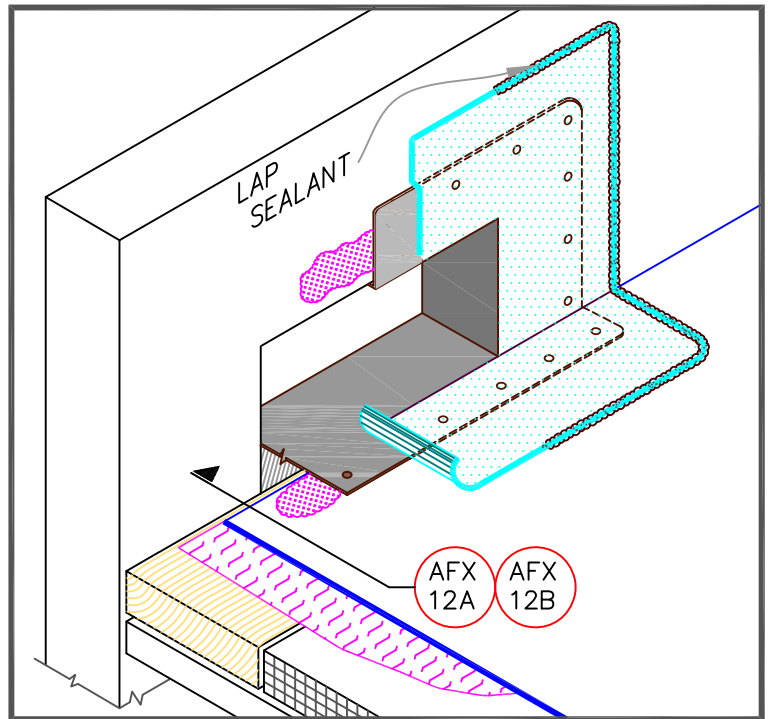

THROUGH-WALL SCUPPER WITH PRESSURE-SENSITIVE EPDM FLASHING

MAXIMUM WARRANTY: 30 YEARS



DETAIL NO.

AFX-18A

AFX ADHERED

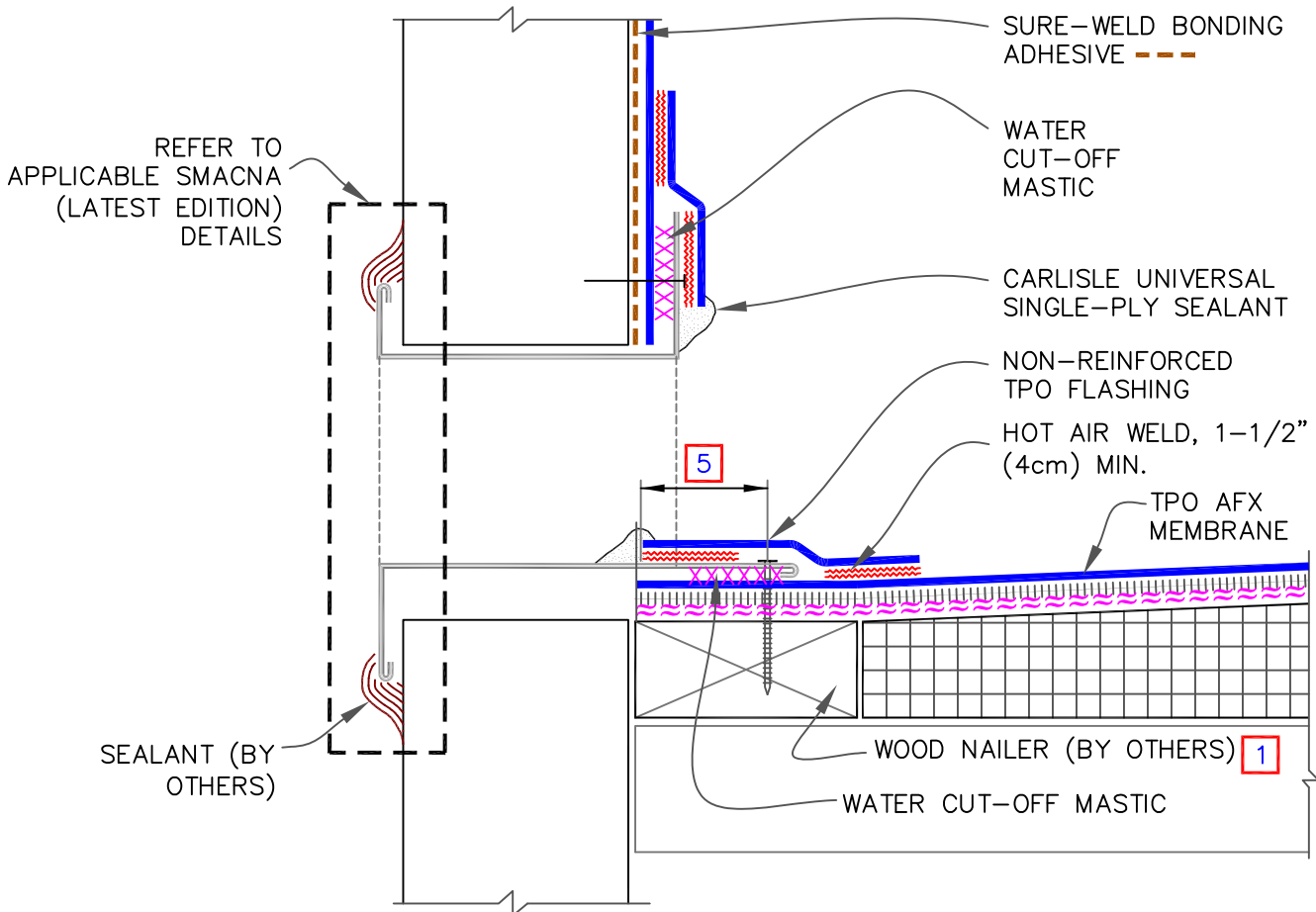

NOTES:

1. WOOD NAILERS ARE INSTALLED ONLY AT SCUPPERS TO SECURE METAL SLEEVE AND MUST EXTEND PAST THE WIDTH OF METAL SLEEVE FLANGE.
2. INSTALL WALL FLASHING PRIOR TO SCUPPER INSTALLATION.
3. METAL SCUPPER BOX MUST HAVE CONTINUOUS FLANGES WITH ROUNDED CORNERS. SOLDER ALL SCUPPER SEAMS WATER-TIGHT.
4. WATER CUT-OFF MASTIC UNDER SCUPPER FLANGE MUST BE UNDER CONSTANT COMPRESSION.
5. SCUPPER FLANGES MUST BE TOTALLY COVERED BY NON-REINFORCED TPO FLASHING WITH MINIMUM 2" (5cm) COVERAGE PAST NAIL HEAD.
6. UNIVERSAL SINGLE-PLY SEALANT IS REQUIRED AT FLASHING EDGES ON SCUPPER EDGE. TPO PRIMER MUST BE USED TO PREPARE SURFACES PRIOR TO THE APPLICATION OF SEALANT.

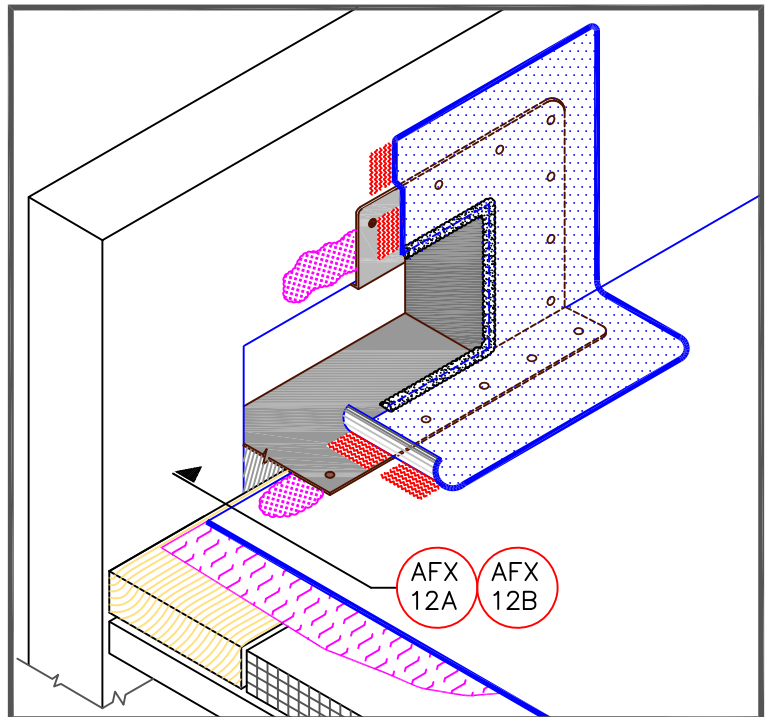

THROUGH-WALL SCUPPER WITH SecurWELD METAL

MAXIMUM WARRANTY: 30 YEARS



DETAIL NO.

AFX-18B

AFX ADHERED

MEMBRANE SPLICE

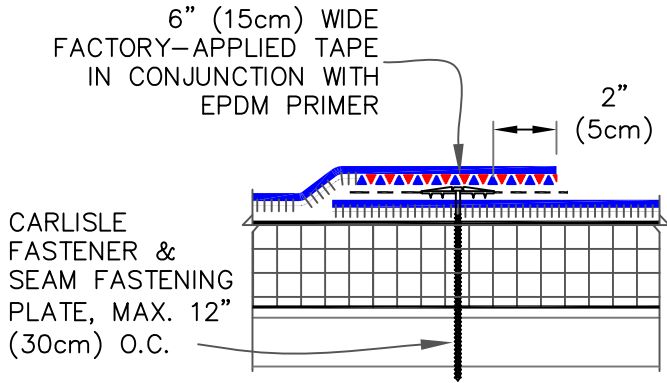

END LAP SPLICE

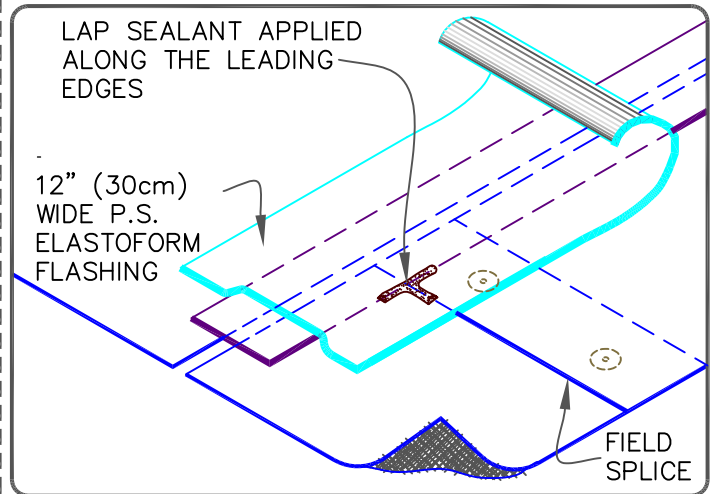
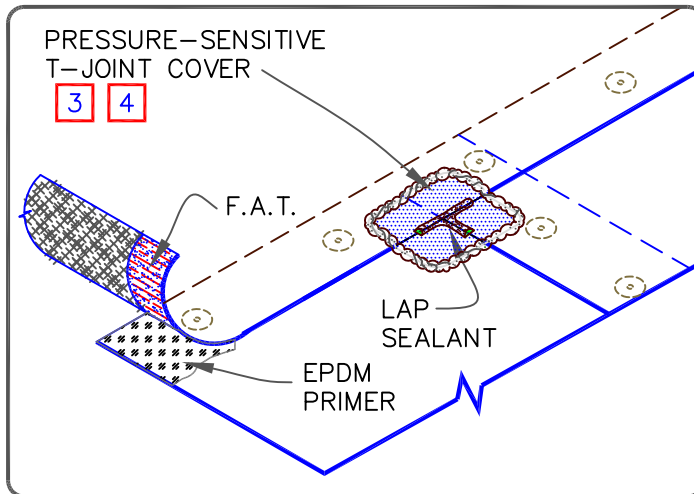
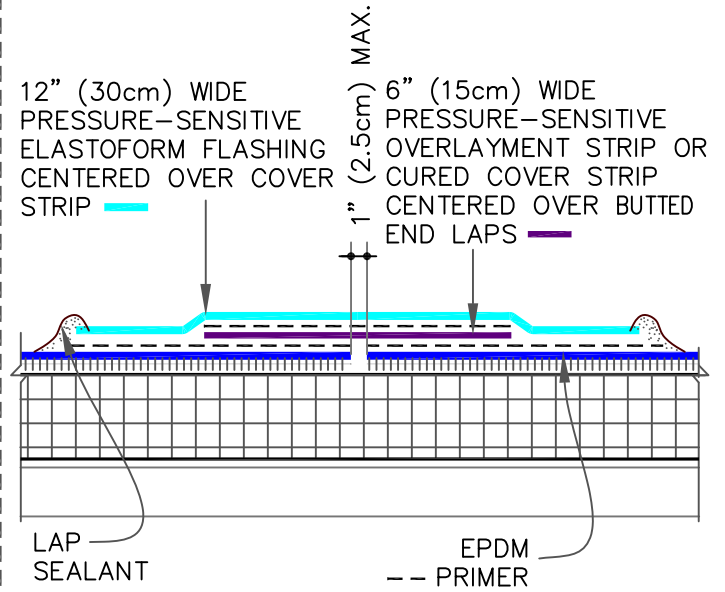

NOTES:

1. REFER TO CARLISLE SPECIFICATIONS FOR ACCEPTABLE CARLISLE FASTENER/PLATE AND FASTENING DENSITY.
2. APPLY EPDM PRIMER TO MEMBRANE SURFACES PRIOR TO INSTALLING PRESSURE-SENSITIVE FLASHING AND/OR FACTORY APPLIED SecurTAPE.
3. APPLY LAP SEALANT ALONG THE EDGE OF THE MEMBRANE SPLICE (UNDER THE 6"x6"(15cm X 15cm) T-JOINT COVER) COVERING THE EXPOSED SPLICE TAPE 1/2" (13 mm) IN EACH DIRECTION FROM THE SPLICE INTERSECTION.
4. 6" (15cm) WIDE PRESSURE-SENSITIVE ELASTOFORM FLASHING MAY ALSO BE CENTERED OVER THE FIELD SPLICE INTERSECTION.

| | | | | |
|----------|------------------------------|--|------------------------------|-------------------|
| | <p>—● AFX EPDM MEMBRANE</p> | <p>AFX EPDM MECHANICALLY FASTENED MEMBRANE & END LAP SPLICES</p> | | <p>DETAIL NO.</p> |
| | <p>—● APPROVED SUBSTRATE</p> | | | <p>AFX-MF1</p> |
| <p>0</p> | <p>—● SEE NOTE(S)</p> | <p>For additional information, refer to Specifications</p> | <p>MECHANICALLY FASTENED</p> | |

MEMBRANE SPLICE

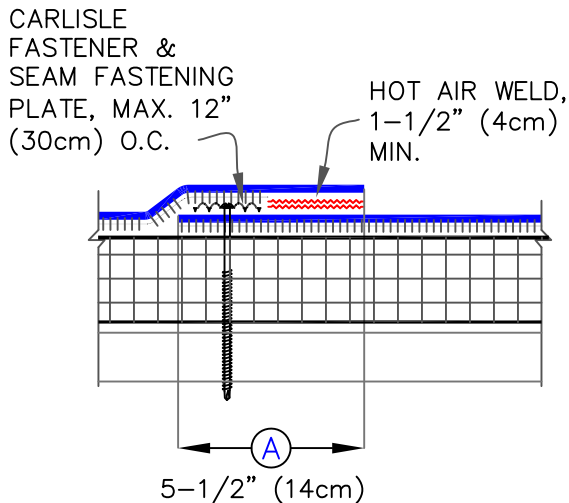

END LAP SPLICE

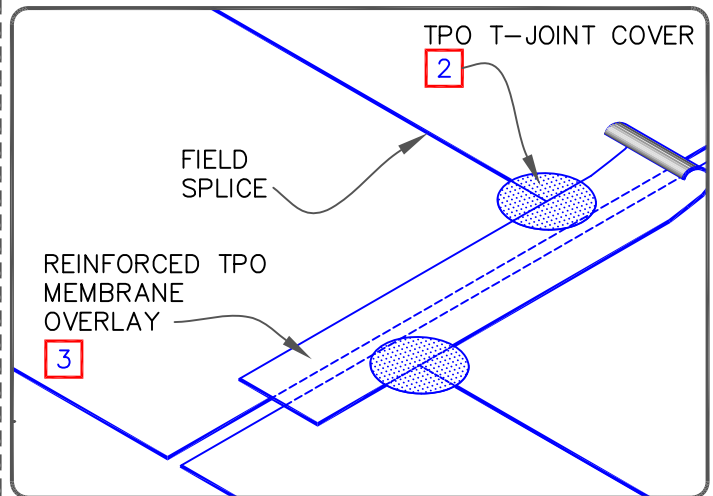
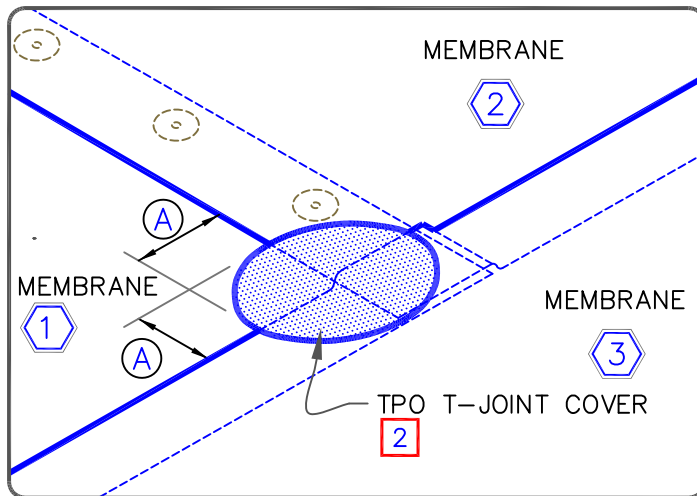
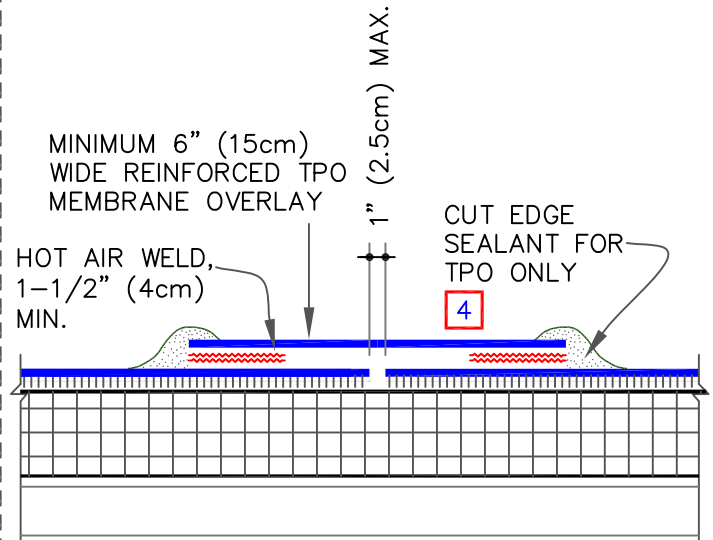

NOTES:

1. REFER TO CARLISLE SPECIFICATIONS FOR ACCEPTABLE CARLISLE FASTENER/PLATE AND FASTENING DENSITY.
2. WHEN USING 135 OR 155-MIL AFX TPO MEMBRANE, APPLY A 4-1/2" (11cm) DIAMETER TPO "T-JOINT" COVER AT ALL FIELD SPLICE INTERSECTIONS.
3. WHEN USING 60 OR 80 MIL TPO REINFORCED MEMBRANE OVERLAY, INTERSECTIONS BETWEEN SPLICES MUST BE OVERLAID WITH A 4-1/2" (11cm) DIAMETER TPO "T-JOINT" COVER, AS SHOWN.
4. APPROXIMATELY 1/8" (0.5cm) DIAMETER BEAD OF CUT-EDGE SEALANT IS REQUIRED ON CUT EDGES OF REINFORCED TPO MEMBRANE.

| | | |
|--|---|--|
| | <p>AFX TPO MECHANICALLY FASTENED MEMBRANE & END LAP SPLICES</p> <p>For additional information, refer to Specifications</p> | <p>DETAIL NO.</p> <p>AFX-MF2</p> <p>MECHANICALLY FASTENED</p> |
|--|---|--|

