



# VERSICO ROOFING SYSTEMS





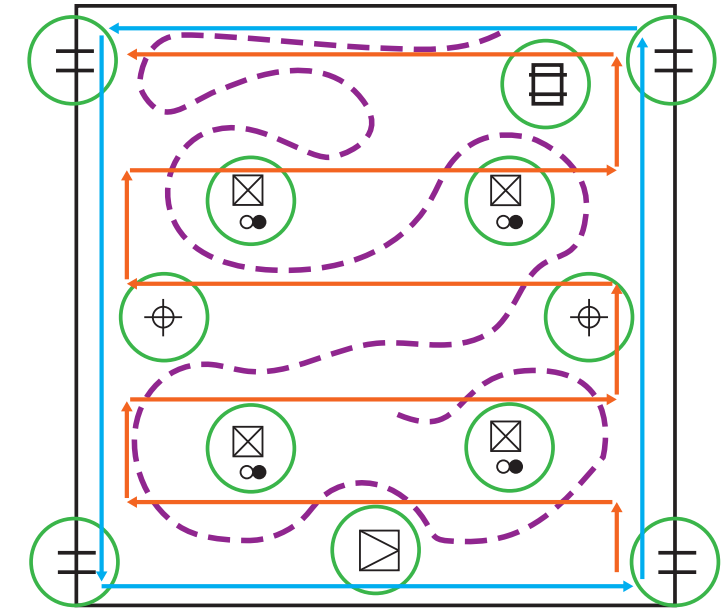

## Quick Reference

### Guide for Inspecting Your System

This guide will illustrate the minimum requirements of a roof inspection and provide a basic understanding of some common details.

Below is a simple roof drawing with penetrations included. It shows the path followed by Versico Field Service Representatives (FSRs) when they inspect a roof for warranty.



-  - Roof Hatch
-  - Curb
-  - Pipe
-  - Pourable Sealer Pocket
-  - Scupper
-  - Drain
-  - Sleeper

- Step 1: Inspect the perimeter.**  
Update the roof plan to show the location of all curbs, penetrations, drains, etc. Focus on securement and termination. Mark deficiencies on the roof plan as they are found.
- Step 2: Inspect all seams on the roof level.**  
Focus on plate placement and proper seaming.
- Step 3: Inspect all curbs, penetrations, drains, etc.**  
Focus on one detail at a time, confirming proper securement, termination, and flashing minimums.
- Step 4: Finally, walk across the roof, update areas in need of repair, and perform a general check of the system.**



Scan the QR Code to view the Inspection Quick Reference Video



### IMPORTANT INFORMATION:

If you need assistance, it's only one call away.

Local FSR phone number:

---

Additional FSR phone number(s):

---

Sales Representative phone number:

---

Technical Sales Representative phone number:

---

Distributor phone number(s):

---

As a reminder, this guide is meant to help with details commonly seen in the field. Not all details are included in this guide. Versico contractors are encouraged to call with any questions.

For assistance, please call 1-800-992-7663 and choose option 2 or ask for the Technical Department.



A SINGLE SOURCE FOR SINGLE-PLY ROOFING  
800.992.7663 • www.versico.com

**Note: This drawing is for your records. Contractors should complete repairs by the end of each work day.**

When the roof has multiple levels, inspect one level at a time. For larger roof levels, break into smaller sections to eliminate confusion.

**NOTE: VERSICO EPDM PRIMER MUST BE USED WITH ALL QUICK-APPLIED PRODUCTS.**

**Additionally, Lap Sealant is required around all edges of Quick-Applied Uncured EPDM Flashing.**

### LAP SEALANT APPLICATION

- 1. Lap Sealant is required at the following locations:**
  - a. Splice tape overlaps.
  - b. Beneath and around the outer edge of 6" x 6" QA T-Joint Covers.
  - c. Where metal edging joints intersect with Quick-Applied Cured Cover Strip.
  - d. Around all edges of Quick-Applied Uncured EPDM Flashing, Corners, and Pockets.
  - e. Cut edges of reinforced membrane.
- 2. Procedures:**
  - a. Dusted EPDM must be cleaned 1" (25 mm) on either side of the splice edge using Weathered Membrane Cleaner/EPDM Primer and HP Splice Wipes/a clean cloth.
  - b. Weathered Membrane Cleaner is not required when using Pre-Cleaned EPDM.
  - c. Apply a 5/16" bead of Lap Sealant centered over the splice edge. Coverage rate is 22 lineal feet per tube.
  - d. Feather the Lap Sealant with the specially designed Lap Sealant Tool so the high point or crown is centered over the splice edge.
  - e. Application of Lap Sealant should be completed each day.



## EPDM (Thermoset) Rooftop Guide/Inspection Checklist

# Common EPDM Thermoset Details

## VGC-1.4 VersiTrim™ Drip Edge Fascia

1. Wood nailer wider than metal flange?
2. Wood nailer flush with insulation?
3. A continuous cleat and the metal must be fastened 6" OC using ring shank nails.
  - a. Installed according to SMACNA ES-1 requirements.
4. Deck flange must be totally covered by QA Cured Cover Strip with minimum 2" coverage past nail heads.
5. Lap Sealant must be applied at flashing overlaps and intersections with joints in metal edging.
  - a. Wood nailers must be securely anchored.
  - b. When using metal by others, the metal flange must be fastened so it does not bow prior to overlaying.
  - c. Joints in gravel stops require a T-Joint Cover.

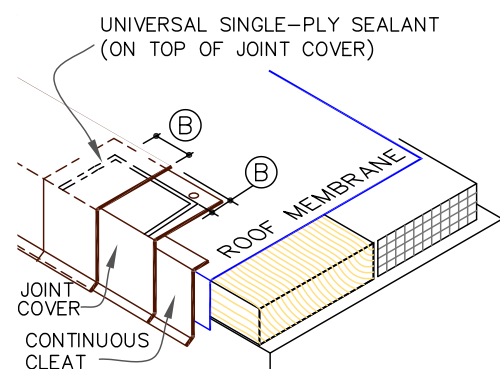

VGC-1.4 VersiTrim Drip Edge Fascia

## VGC-2.1A/VGMA-2.1 Membrane Splice

1. Was 6" Quick-Applied Seam Tape used on a mechanically fastened seam?
2. Check usage of EPDM Primer and overage/trailing edge.
3. Tape exposure minimum 1/8" to 1/2".
4. Lap Sealant used at cut edges of reinforced membranes.
5. Cured-to-cured splices (T intersection): is an uncured QA T-Joint Cover present with Lap Sealant under and around the T-Joint?
  - a. Walk all splices to verify no fishmouths or other defects.

## VGC-5.1 Curb Flashing

1. Minimum splice present on roofing system? 3" or 6" Quick-Applied Seam Tape.
2. Membrane terminated properly at the top of the curb?
  - a. Counter-flashing used? If so, was it fastened with neoprene washers?
  - b. Fasteners underneath the metal counter-flashing?
  - c. Is Water Cut-Off Mastic present?
3. Membrane securements at the inside angle change?
4. Outside corners complete without bridging? (Lap seal corner flashings.)
5. If termination bar used: Follow VGC-9.4 details.

## VGC-6.1 Roof Drain Details

1. Are all drain bolts/clamps in place to provide constant compression?
2. Hole in membrane must be larger than drain hole itself, minimum 1/2" from inside the drain ring.
3. Is Water Cut-Off Mastic present between the cleaned drain bowl and the membrane?
4. No seams in drain. Field splices must be located at least 6' outside the drain sump.

5. Drain ring must not be broken/cracked; must be replaced if damaged.
  - a. If a target splice is needed at a drain with a warranty of 20 or more years, the target splice must be overlaid with 6" QA Flashing.

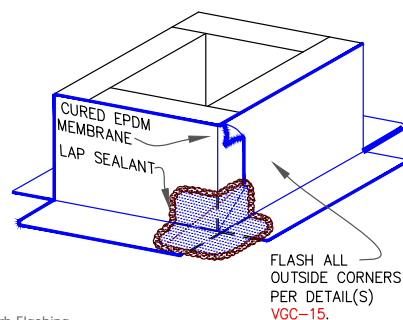

VGC-5.1 Curb Flashing

## VGC-8 Pipes/Single Penetrations

**Note: Temperature of pipes must not exceed 180°F. Field Fabricated Hot Stack must be installed per VGC-8.5 (pg. 48 in Rooftop Detail Guide.)**

### QA Molded Pipe Seal

1. On flat surface? Flanges cannot be overlapped.
2. Cut in Pipe Seal above rib?
3. Water Cut-Off Mastic and clamp present at top of pipe seal?

### QA Field-Fabricated Pipe Seal

1. Two wraps present.
  - a. Base wrap goes up pipe 1/2" minimum?
  - b. Top wrap overlaps base wrap 1" with a 3" splice on the vertical overlap?
  - c. Lap Sealant present around all edges of Quick-Applied Uncured EPDM Flashing?
  - d. Securement is needed at any pipes greater than 18" in diameter.

## VGC-9.0 Membrane Terminations

1. If warranty is 15 or more years, termination bar must be present.
  - a. For warranties greater than 20 years, counter-flashing and termination bar must be used.
2. Water Cut-Off Mastic present?
3. Universal Single-Ply Sealant/sealant by others present at top of termination bar?
  - a. If counter-flashing is used, sealant is required at top edge of metal flashing, not on top of termination bar.
4. Termination bar not bent?
5. Fastening of bar shall never exceed 12" OC, and must always be fastened enough to keep constant compression on Water Cut-Off Mastic.
6. Do not wrap termination bar around corners. Apply on hard, smooth surfaces only; not for use on exposed wood.
  - a. See detail VGC-9.5 for additional requirements if termination bar is used at tilt-up panel joints.
  - b. Water Cut-Off Mastic must be installed at approximately 10' per tube.

## VGC-12 Parapet/Curb Angle Change

1. Is securement present? Primer is required to mate membrane to RTS; bonding adhesive is not acceptable.
  - a. Appropriate fastening? No more than 12" OC.
  - b. 6" OC if wind speed greater than 90 mph.
2. Verify all flashings are properly adhered.

3. If seam is present at angle change, a QA T-Joint Cover is required.
  - a. Lap Sealant is required around the QA T-Joint Cover.
4. How is membrane terminated?
  - a. See Detail VGC-9.0.

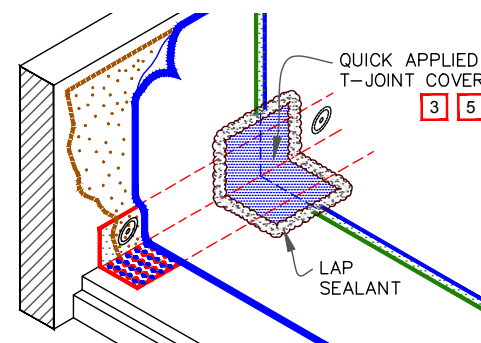

VGC-12 Parapet/Curb Angle Change

## VGC-13 Tie-Ins to Existing Roofing System

1. Membrane securement present?
2. If the deck slopes toward the new roofing system refer to the tie-in details: concrete deck termination or weep holes steel deck.
3. For built-up roof tie-ins:
  - a. Cold tie-in: Quick-Applied Uncured EPDM Flashing used with Two-Part Pourable Sealer?
  - b. Hot tie-in: multiple layers of felt and asphalt must be used, per pg. 55 of the Rooftop Detail Guide. Detail VGC-13.2.
4. Tie-ins for existing membrane/EPDM or VGC-13.3, 4.
  - a. QA Cured Cover Strip or field membrane in conjunction with Quick-Applied Seam Tape.
5. Shingle roof tie-ins VGC-13.5: extend above anticipated slush line.
6. When a tie-in is needed to PVC, a complete isolation of the system must be built.

## VGC-15 Inside/Outside Corner With or Without QA RTS

1. Membrane securement at the angle change present?
2. Plates and fasteners 6"-9" away from inside/outside corner?
3. Plates and fasteners a minimum 12" OC? (6" must be used when warranty wind speed is greater than 90 mph: see VGC-12 Details on pg. 51 in Rooftop Detail Guide.)
4. Pig ear fold in inside corner:
  - a. Quick-Applied Seam Tape present behind fold?
  - b. Quick-Applied Uncured EPDM Flashing used to cover overlap membrane/pig ear?
  - c. Is Lap Sealant present around Quick-Applied Uncured EPDM Flashing?
5. When flashing inside or outside corners, use:
  - a. 7" x 9" factory-made uncured Inside/Outside Corners.
  - b. When field-fabricating, 9" x 9" Quick-Applied Uncured EPDM Flashing must be used.

## VGC-16 Pourable Sealer Pockets

1. Used on multiple hard-to-flash penetrations. Pipe clusters must have minimum 1" clearance between penetrations.
2. All areas inside Pourable Sealer Pocket and all penetrations must be primed.

3. Pourable sealer minimum 2" deep?
4. 3" minimum overlap of product and 3" on deck?
5. Lap Sealant present around all edges of Quick-Applied Uncured EPDM Flashing?
6. Securement is required on mechanically fastened systems; not required on adhered systems.
  - a. Securement is required for pourable sealer pockets larger than 18" in diameter on adhered systems.

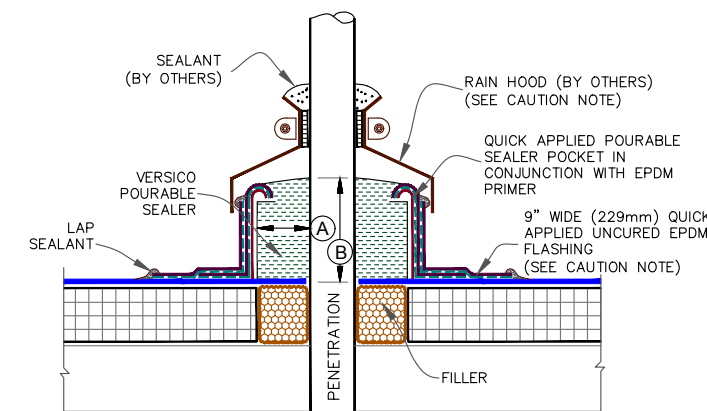

VGC-16 Pourable Sealer Pockets

## VGC-18.1 Metal Scupper

1. Metal scupper box must have a continuous flange with rounded corners.
2. Wood nailer present underneath metal?
3. Water Cut-Off Mastic present underneath metal and on top of membrane?
4. Lap Sealant present around Quick-Applied Uncured EPDM Flashing?
5. Where the scupper meets the outside wall, sealant by others is needed.

## VGC-24.0 Sleepers/Wood Blocking

1. Slip sheets present underneath to prevent damage to new membrane?
2. Check usage of Walkway Pads.
  - a. Present at all fixed access points/HVAC units that are regularly serviced/concentrated walk areas?

## A-27/MA-27 Insulation Fastening

1. Verify fastening of insulation is in accordance with current specifications and details.
2. Verify proper fastener penetration.
3. Reduced fastening patterns are only allowed on: 22-gauge or heavier steel, concrete, minimum 1.5" wood, or 3/4" plywood decks.