

Table of Contents

January 2026

The information contained in this generic specification represents a part of Versico’s requirements for obtaining a roofing system warranty. Construction materials and practices, building siting and operation, climatic conditions, and other site-specific factors will have an impact on the performance of the roofing systems. Versico recommends that the building owner retain a design professional to determine appropriate design measures to be taken in order to address these factors.

Construction Generated Moisture.....	DR-01
FM 1-28 Summary Update.....	DR-02
FM 1-29 Summary Update – Adhered Roofing Systems	DR-03
FM 1-29 Summary Update – Mechanically Fastened Roofing Systems.....	DR-04
Insulation Fastening Patterns.....	DR-05
Withdrawal Resistance Criteria.....	DR-06
CRRC/LEED Information.....	DR-07
Wood Nailers and Securement Criteria.....	DR-08
Considerations for Hail Design.....	DR-09
Metal Edging.....	DR-12

Construction Generated Moisture

January 2026

The information contained in this supplement serves as criteria for Specifiers and Authorized Contractors regarding the design and installation of Versico Roofing Systems and related products. Additional information essential for the design and installation of the Roof Systems mentioned herein are also included in the respective Specification for each Roof System and in the Design Reference Section of the Versico Technical Manual. Specifiers and Authorized Contractors are advised to reference all applicable sections.

While buildings should ultimately be designed to fit their intended purpose and accommodate their occupants, they must also tolerate various construction conditions (i.e., time of construction, material and process used).

In cold climatic regions, buildings in their construction phase will most likely experience an aggressive upward moisture drive as a result of hydration of freshly poured concrete floors and the practice of using oil or propane fired heaters.

According to National Roofing Contractors Association (NRCA):

1. Construction processes can release large quantities of water vapor. For example, wall or ceiling plaster or 4" thick concrete slabs release roughly one quart of water (2 pounds) for each square foot of surface area during the drying process. A building that is 120,000 square feet in size could experience up to 30,000 gallons of construction-generated moisture.
2. The combustion process of an oil-or propane-fired heater, used for temporary heat during construction, produces more water as a by-product of burning than the weight of the fuel consumed. Approximately one gallon of water will be produced for each gallon of heating oil burned. This generated moisture, if not addressed through ventilation or contained using vapor retarders, will subject the roof assembly to potential harmful effects that vary from mold accumulation to reduced insulation efficiency.

Moisture Migration

Moisture vapor penetrates a roof assembly either by air leakage or by diffusion.

1. Air leakage occurs through joints in the metal deck or tilt-up panels, insulation and joints and gaps around penetrations. Air leakage will also occur as a result of imperfections, such as punctures and tears. Air leakage can allow the transport of significantly greater amounts of moisture than can be transported by way of diffusion.
2. Diffusion of moisture is caused by the differences in vapor pressure that occur with varying temperature conditions and relative humidity. The greater the temperature differential, the more active the moisture drive.

Air Infiltration

Humid internal air migrating upward through these joints and gaps could cause condensation. If the condensation occurs beneath the roofing membrane it could freeze, in colder temperatures (frozen moisture makes a crackling noise when walked on in winter). If the condensation occurs in the layers of insulation it could eventually weaken the bottom insulation facer which would compromise the wind performance. When a continuous vapor barrier is not to be used, infiltration of humid air, can be prevented by sealing joints and gaps. To achieve an air-tight seal, all gaps may be sealed as illustrated. In addition, vertical joints in pre-cast tilt-up panels and construction gaps resulting at inside and outside corners must be completely sealed to eliminate interior air from reaching the roofing assembly.

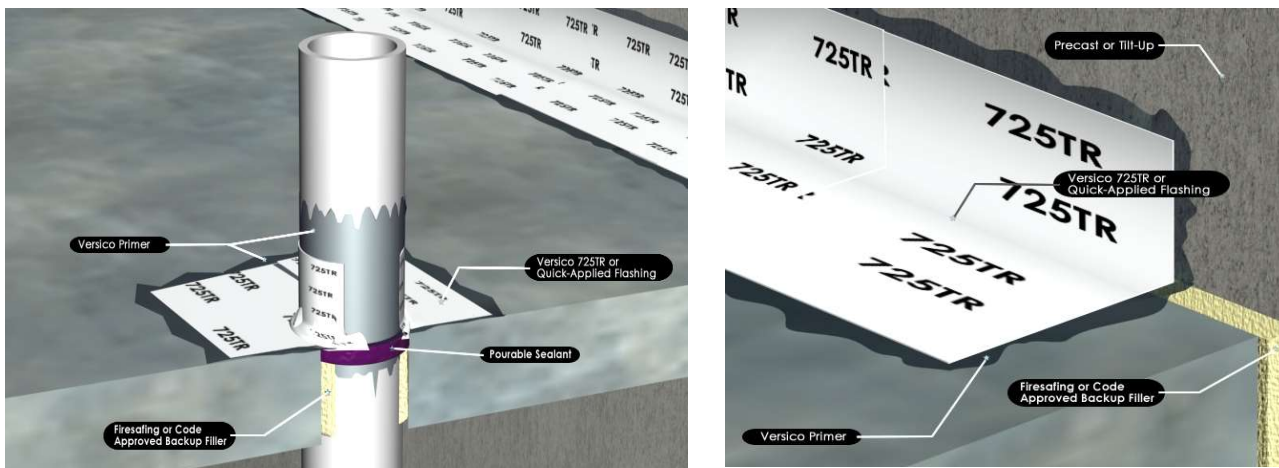

Gaps must be filled with firesafing or building code approved backup filler.

Versico's VapAir Seal 725 TR or Quick-Applied Flashing can be used as shown in illustrations after priming the substrate. For the VapAir Seal 725 TR, use as a substrate primer Versico's CAV-GRIP 3V, CCW 702, CCW 702-LV or CCW 702WB, and for the VersiGard® Quick-Applied Flashing, use Versico's EPDM Primer.

Projects with Steel decks, deck-to-wall junctions may be sealed using the Versico's VapAir Seal MD directly to the steel deck, without the use of a primer.

Preventing Moisture Damage

While occupancy generated moisture is usually addressed using a vapor retarder, construction generated moisture can be addressed by:

1. Reducing accumulated construction moisture
2. Sealing gaps between the structural deck and walls as well as gaps around penetrations (utilizing VapAir Seal Flashing Foam or VapAir Seal MD) and at the steel deck end laps (utilizing VapAir Seal MD).
3. Using of multiple layers of insulation can also provide an additional barrier, in the event of air infiltration and reduces the level of moisture concentration within the roofing assembly.

Note: Studies have also revealed an 8 - 10 % reduction in energy costs between assemblies with equal R-Value when designed with multiple layers versus those designed with a single layer of insulation.

4. Construction generated moisture can also be reduced by project dehumidification prior to building occupancy.

Copyright 2026 Versico

Versico, VersiGard, VapAir Seal and VersiFleece are Trademarks of Versico

This Spec Supplement represents the applicable information available at the time of its publication. Owners, Specifiers and Versico authorized roofing contractors should consult Versico or their Versico Independent Sales Representative for any information that has subsequently been made available.

Review the appropriate Versico Warranty for specific warranty coverage, terms, conditions and limitations.

FM 1-28 Summary Update

January 2026

This Design Reference document offers a summary of updates to the FM 1-28 Property Loss Prevention Data Sheet announced by FM Global in February 2020.

Specifiers, Applicators or Building owners must access the FM website for other related information and contact the local FM office when working on a FM insured property. Enhancements mandated by FM Global for an FM insured property are not necessarily part of Versico's requirements for the issuance of the Versico warranty. When an inspection is performed by Versico, it is not to verify compliance with the FM requirements but to ensure Versico's minimum warranty requirements have been met.

FM 1-28 Recent Update

One key update relates to roof zone dimensions to align with the ASCE 7-16 Design Standards. In some cases (depending on the roof dimensions, building height, and roof slopes), four zones may exist: interior, inner perimeter (also referred to as field), outer perimeter, and corner zones. The Roof Zone table below may be referenced for more detailed information.

Roof Height / Slope	Reference	Corner Zone (Zone 3)	Outer Perimeter Zone (Zone 2)	Inner Perimeter / Field Zone (Zone 1)	Interior Zone (Zone 1')
Building slopes less than 1- 1/2" (7° or less) OR Buildings less than 90' with height to width ratio of 1.0 or less	Figure I	0.6h x 0.6 x 0.2h "L" shaped	0.6h from roof edge	1.2h from roof edge	Covers the remaining roof area
Building slopes 1-1/2" or greater (greater than 7°)	Figure II	The width (a) of the various perimeter and corner zones equals the lesser of 10% of the building width or 0.4h, but not less than 4% of the width or 3ft.		Covers the remaining roof area	N/A
Buildings 90'-high or taller, or buildings higher than 60' with height to width ratio greater than or equal to 1.0	Figure III	The depth of the corner and perimeter zones shall equal 10% of the building width dimension, but not less than 3ft (0.9m). The corner zone shall extend along both perimeters a distance equal to twice the depth forming an "L" pattern.		Covers the remaining roof area	N/A

Note: h = building height

Other important items to note include:

- 1- Revised design wind guidance reflects changes in pressure coefficients (GCP).
- 2- The basic design wind speed maps for the continental United States and Alaska remain unchanged and are still based on ASCE 7-05.
- 3- Wind pressure tables have been removed. Roof pressures can be determined by using either the RoofNav Ratings Calculator or the pressure calculations in section 3.0 of 1-28. Also, pressure coefficients have been provided as outlined in the tables included with Figure I, Figure II, and Figure III.
- 4- A separate 100-year MRI wind map has been provided for each of the islands of Hawaii, instead of using one wind speed for all the islands.

Figure I

Building slopes less than $1\text{-}1/2^\circ$ (7° or less)

OR

Buildings less than 90' with height to width ratio of 1.0 or less

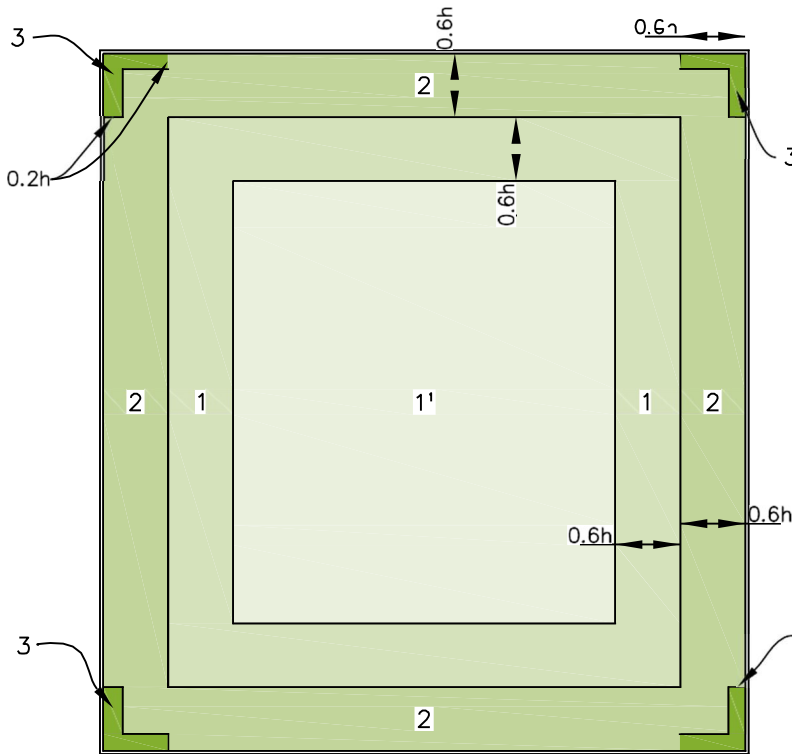

Zone	GCP
Corner Zone (3)	-3.2
Outer Perimeter Zone (2)	-2.3
Inner Perimeter / Field Zone (1)	-1.7
Interior Zone (1')	-0.9

Figure II

Building slopes 1-1/2" or greater (greater than 7°)

Note: a = the width of the various perimeter and corner zones equals the lesser of 10% of the building width or 0.4h, but not less than 4% of the width or 3' (0.9 m).

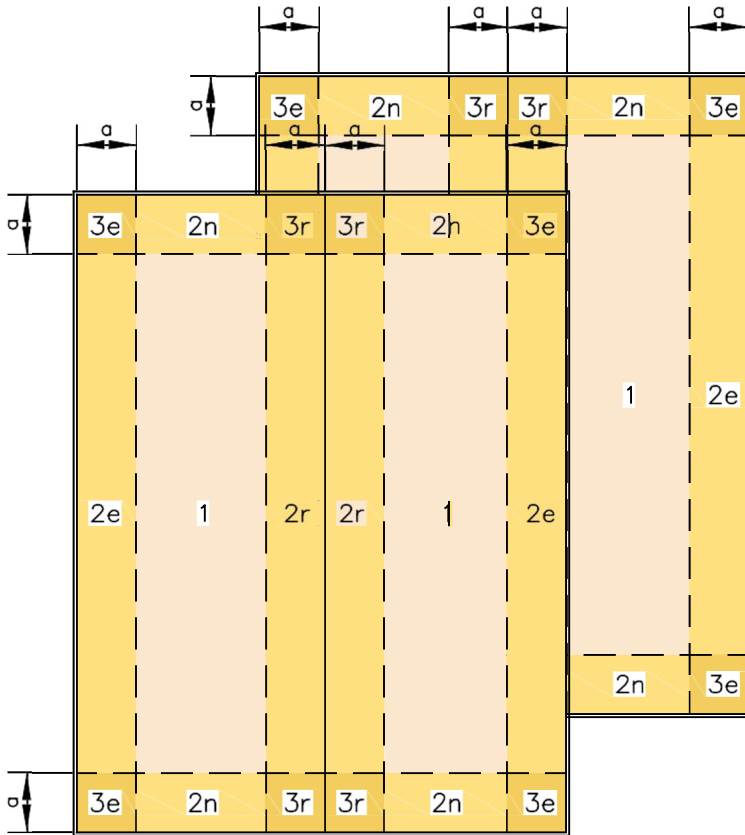

Zone	GC _P
Corner Zone (3r)	-3.6
Outer Perimeter Zone (2n, 2r, 3e)	-3
Inner Perimeter / Field Zone (1, 2e)	-2

This table contains conservative GC_P values for slopes 1-1/2" or greater. For lesser values for steeper slopes, refer to FM 1-28 table 3.2.2d or table 3.2.2c.

Figure III

Buildings 90' high or taller, or buildings higher than 60' with height to width ratio greater than or equal to 1.0

Note: $a = 10\%$ of the lesser horizontal dimension, but not less than 3' (0.9m).

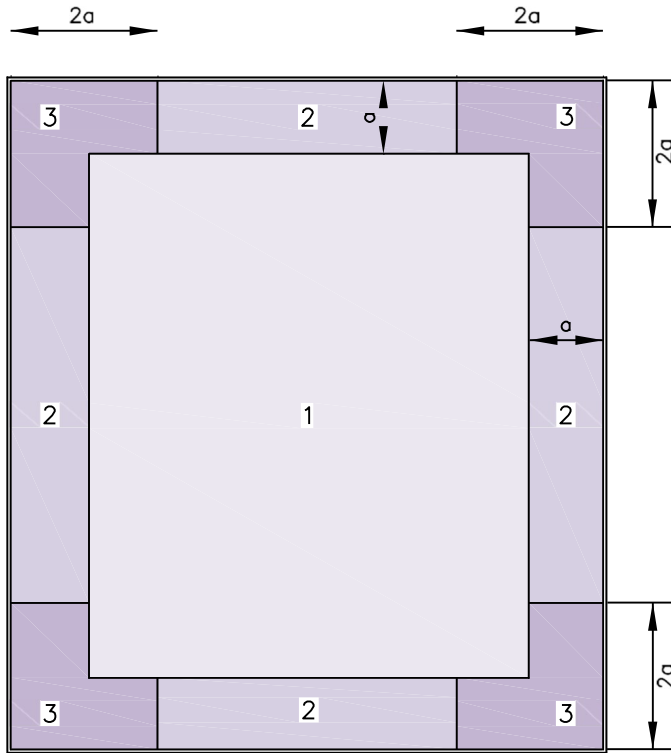

Zone	GCP
Corner Zone (3)	-3.2
Outer Perimeter Zone (2)	-2.3
Inner Perimeter/Field Zone (1)	-1.7

This document is intended for informational reference only and shall not be considered a replacement to the actual FM 1-28 publication. All FM-insured projects must be reviewed by the local FM Engineering office before beginning any roofing work.

Additional information may be obtained by logging on to <https://www.roofnav.com> to access the RoofNav number search, RoofNav Ratings Calculator, and all applicable Property Loss Prevention Data Sheets.

Copyright 2026 Versico

Versico is a Trademark of Versico

This specification represents the applicable information available at the time of its publication. Owners, specifiers and Versico authorized roofing contractors should consult Versico or their Versico Independent Sales Representative for any information, which has subsequently been made available.

Review the appropriate Versico warranty for specific warranty coverage, terms, conditions and limitations.



DR-03

FM 1-29 Summary Update Adhered Roofing Systems

January 2026

This Design Reference document offers a summary of updates to the FM 1-29 Property Loss Prevention Data Sheet for adhered roofing systems announced by FM Global in February 2020.

Specifiers, Applicators or Building owners must access the FM website for other related information and contact the local FM office when working on a FM insured property. Enhancements mandated by FM Global for an FM insured property are not necessarily part of Versico's requirements for the issuance of the Versico warranty. When an inspection is performed by Versico, it is not to verify compliance with the FM requirements but to ensure Versico's minimum warranty requirements have been met.

A summary of the changes made to the FM 1-29 document that affect adhered roofing systems include the following:

New designations for field, perimeter and corner areas. Now referred to as Zones 1, 2 and 3, respectively.
Addition of a new secondary interior field area, designated as Zone 1' ("Zone 1 Prime").
Modified perimeter and corner prescriptive insulation attachment enhancements for adhered roofing systems utilizing ribbon adhesive. (Mechanically attached insulation enhancements have not changed).

This Design Reference will focus on the February 2020 FM 1-29 prescriptive enhancement requirements for insulation attachment using mechanical fasteners and ribbons of adhesive on adhered roofing systems.

Prescriptive Enhancements – Adhered Systems

Prescriptive enhancements for Zones 2 and 3 of a building are acceptable when either of the following conditions are met.

- The FM Zone 1 rating in any location does not exceed 1-90, **OR**
- The building is located in a non-tropical cyclone-prone region and the Zone 1 rating does not exceed 1-105.

Buildings that do not meet these criteria must use a roofing system with a FM approved wind uplift rating that meets or exceeds the design rating for each Zone (Zones 1', 1, 2, and 3).



Adhered Systems Using Mechanical Fasteners

The method for prescriptively enhancing adhered systems that utilize mechanically fastened insulation has not changed. The attachment requirements are as follows:

- Zone 2 - 50% increase over Zone 1 but no less than 1 fastener/plate per 2 ft² (16 per 4'x8' board).
- Zone 3 - 1 fastener/plate per 1 ft² (32 per 4'x8' board).

Mechanically Fastened Insulation Example

A roofing assembly specified for use in a non-tropical cyclone-prone region achieves a 1-105 wind uplift rating using 1 fastener/plate per 2 sq. ft. (16 per 4'x8' board). The enhanced Zone fastening would be as detailed in the following table.

1-105 Rated Adhered Assembly – Fastened Insulation			
Zone 1' Fastening	Zone 1 Fastening (Tested)	Zone 2 Fastening (50% increase of Zone 1)	Zone 3 Fastening
Use Zone 1 or alternate system meeting Zone 1' rating requirements	16 fasteners per 4'x8' board	24 fasteners per 4'x8' board	32 fasteners per 4'x8' board

The plan view fastening for this example would appear as shown below. Zone 1' is not shown.

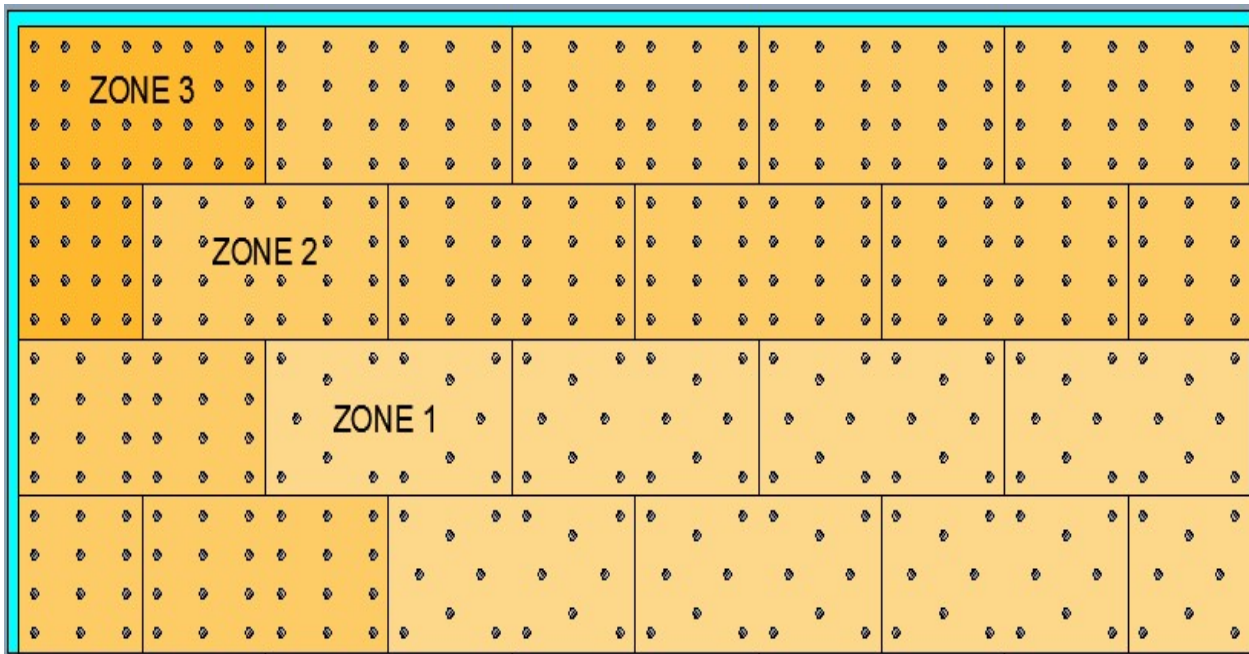

Adhered Systems Using Ribbon Applied Adhesives

The method for prescriptively enhancing insulation attachment with ribbon applied adhesive on adhered systems has changed. The Zone 2 reduction in spacing between ribbons has changed from 60% (previously allowed) to 67% of the tested Zone 1 spacing. Likewise, the Zone 3 reduction of spacing between ribbons has changed from 40% to 50% of the Zone 1 spacing.

Ribbon Attached Insulation Example

A roofing assembly specified for use in a non-tropical cyclone-prone region achieves a 1-105 wind uplift rating using ribbons of adhesive spaced 12" o.c. The enhanced Zone ribbon spacing would be as detailed in the following table.

1-105 Rated Adhered Assembly – Adhesive Ribbons			
Zone 1' Spacing	Zone 1 Spacing (Tested)	Zone 2 Spacing (67% of Zone 1)	Zone 3 Spacing (50% of Zone 1)
Use Zone 1 or alternate system meeting Zone 1' rating requirements	12" o.c. Max.	8" o.c. Max.	6" o.c. Max.

The plan view ribbon spacing for this example would appear as shown below. Zone 1' is not shown.

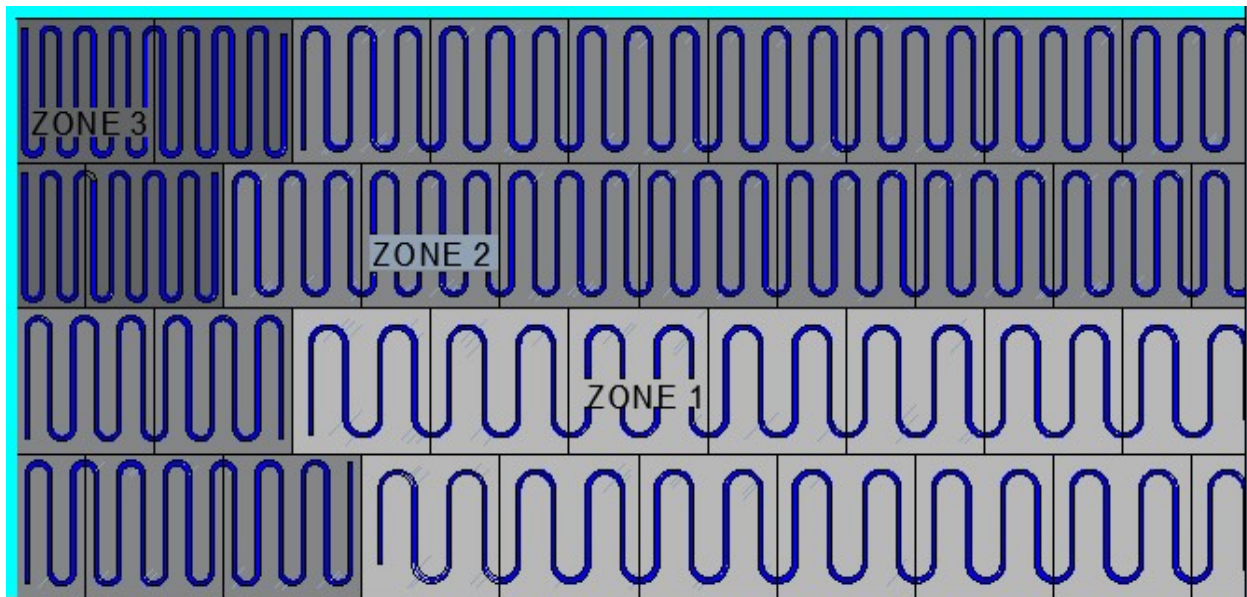

Non-Prescriptive Enhancements

The option is always available to provide a roofing system that has been tested to achieve the uplift pressure requirement / FM rating for each roof Zone. As such, a system that meets the Zone 3 requirements may be installed over the entire roof, or multiple systems may be installed to meet the individual Zone 1', 1, 2 and 3 design pressures.

This document is intended for informational reference only and shall not be considered a replacement to the actual FM 1-29 publication. All FM-insured projects must be reviewed by the local FM Engineering office before beginning any roofing work.

Additional information can be obtained by logging on to <https://www.roofnav.com> to access the RoofNav number search, RoofNav Ratings Calculator, and all applicable Property Loss Prevention Data Sheets.

Copyright 2026 Versico

Versico is a Trademark of Versico

This specification represents the applicable information available at the time of its publication. Owners, specifiers and Versico authorized roofing contractors should consult Versico or their Versico Independent Sales Representative for any information, which has subsequently been made available.

Review the appropriate Versico warranty for specific warranty coverage, terms, conditions and limitations.



DR-04

FM 1-29 Summary Update Mechanically Attached Roofing Systems

January 2026

This Design Reference document offers a summary of updates to the FM 1-29 Property Loss Prevention Data Sheet for adhered roofing systems announced by FM Global in February 2020.

Specifiers, Applicators or Building owners must access the FM website for other related information and contact the local FM office when working on a FM insured property. Enhancements mandated by FM Global for an FM insured property are not necessarily part of Versico's requirements for the issuance of the Versico warranty. When an inspection is performed by Versico, it is not to verify compliance with the FM requirements but to ensure Versico's minimum warranty requirements have been met.

An updated version of the FM 1-29 Property Loss Prevention Data Sheet was published in February 2020. Changes made to that document that affect mechanically fastened roofing systems include the following:

New designations for field, perimeter and corner areas. Now referred to as Zones 1, 2 and 3, respectively.
Addition of a new secondary interior field area designated as Zone 1' ("Zone 1 Prime").
Addition of a calculated, performance-based attachment enhancement method for Zones 2 and 3.
Modified prescriptive enhancement attachment requirements for Zones 2 and 3.

This Design Reference will focus on the 2020 FM 1-29 performance-based and prescriptive enhancement requirements for membrane attachment on mechanically fastened roofing systems. This includes linear induction-welded systems.

Performance-Based Enhancement

FM has added an option into 1-29 for the performance-based enhancement of Zones 2 and 3 for mechanically fastened membrane systems. The determination is based on the membrane width and the fastener spacing of the tested assembly chosen for Zone 1. The following example is offered for clarification.



Performance-Based Enhancement Option Example

The FM RoofNav Ratings Calculator was used to determine that an example building requires the following wind uplift ratings:

Zone 1'	Zone 1	Zone 2	Zone 3
90 psf (1-90)	120 psf (1-120)	150 psf (1-150)	210 psf (1-210)

Choose a roofing system that has been tested to meet or exceed the **Zone 1 rating** which for this example is a 12' wide membrane fastened 6" oc. The Zone 1' pressure is less than Zone 1 so the as-tested assembly can be used in Zone 1'. However, since the Zone 2 and Zone 3 pressures exceed the tested Zone 1 pressure (120 psf), the membrane width must be reduced (to increase the membrane fastening density) in these areas while maintaining the 6" oc fastener spacing. The calculations for Zones 2 and 3 are as follows.

Step 1: Determine the area of membrane secured by a single fastener for Zone 1:

- Fastener row spacing *times* the fastener spacing along the row;
 - 11.5 ft (12' sheet minus seam overlap) x 0.5 ft (6" oc fastener spacing) = 5.75 ft² (per fastener securement area)

Zone 2 Enhancement

Step 2: Determine the needed reduction in the area of membrane secured by a single fastener for Zone 2:

- Zone 1 tested pressure *times* fastener securement area *divided by* Zone 2 pressure;
 - 120 psf x 5.75 ft² / 150 psf = 4.6 ft² per fastener

Step 3: Determine the reduction in fastener row spacing for Zone 2:

- Zone 2 area of membrane secured by a single fastener *divided by* fastener spacing;
 - 4.6 ft² / 0.5 ft = 9.2 ft maximum row spacing with fasteners spaced 6" oc

Zone 3 Enhancement

Step 4: Determine the needed reduction in the area of membrane secured by a single fastener for Zone 3:

- Zone 1 tested pressure *times* fastener securement area *divided by* Zone 3 pressure;
 - 120 psf x 5.75 ft² / 210 psf = 3.3 ft² per fastener

Step 5: Determine the reduction in fastener row spacing for Zone 3:

- Zone 3 area of membrane secured by a single fastener *divided by* fastener spacing;
 - 3.3 ft² / 0.5 ft = 6.6 ft maximum row spacing with fasteners spaced 6" oc

The following table summarizes the performance-based example results calculated above.

Performance-Based Example Summary

Zone 1'	Zone 1 – Tested	Zone 2	Zone 3
Use Zone 1 or system passing 1-90	12' Sheets 11.5' Row Spacing 6" oc Fastener Spacing	9.2' Row Spacing 6" oc Fastener Spacing	6.6' Row Spacing 6" oc Fastener Spacing

Prescriptive Enhancement Option

The FM prescriptive enhancement option has always been available for mechanically fastened systems and is a simple way to determine the reduction in membrane sheet width / fastener row-to-row spacing for Zones 2 and 3. This method, like the performance-based method, is based on the testing results for Zone 1. The following table contains a summary of the prescriptive enhancement requirements.

Zone 1'	Zone 1 – Tested	Zone 2	Zone 3
Use Zone 1 or separately tested system	Tested Spacing	67% of Zone 1 Fastener Row-To-Row Spacing (60% previously)	50% of Zone 1 Fastener Row-To-Row Spacing (40% previously)

Prescriptive Enhancement Option Example

A FM Approved roofing system requires the use of a 12' wide membrane (11.5' oc fastener row spacing) with fasteners spaced 6" oc along the row. The following table identifies the prescriptive enhancement requirements.

Zone 1'	Zone 1 – Tested	Zone 2 (67%)	Zone 3 (50%)
Use Zone 1 or separately tested system	12' Sheets 11.5' Row Spacing 6" oc Fastener Spacing	7.7' Row Spacing 6" oc Fastener Spacing	5.75' Row Spacing 6" oc Fastener Spacing

In summary, either the performance-based enhancement or the prescriptive enhancement option can be used to comply with the FM 1-29 2020 update. Please refer to the FM Global publications for all the applicable requirements.

This document is intended for informational reference only and shall not be considered a replacement to the actual FM 1-29 publication. All FM-insured projects must be reviewed by the local FM Engineering office before beginning any roofing work.

Additional information can be obtained by logging on to <https://www.roofnav.com> to access the RoofNav number search, RoofNav Ratings Calculator, and all applicable Property Loss Prevention Data Sheets.

Copyright 2026 Versico

Versico is a Trademark of Versico

This specification represents the applicable information available at the time of its publication. Owners, specifiers and Versico authorized roofing contractors should consult Versico or their Versico Independent Sales Representative for any information, which has subsequently been made available.

Review the appropriate Versico warranty for specific warranty coverage, terms, conditions and limitations.

Insulation Fastening Patterns

January 2026

The information contained represents guidelines to address possible requirements as part of the building specification as listed under the Quality Insurance or Performance Article. Versico recommends that the building owner retain a design professional to verify that these guidelines are appropriate.

When enhanced insulation fastening is required as prescribed in Factory Mutual Loss Prevention Data Sheet 1-29, ANSI/SPRI WD-1, or Miami-Dade County, the specifier may consider the enclosed insulation pattern securements.

NOTE: All insulation and underlayments shown are the minimum thickness required for the established rating.

Insulation Patterns for boards 4' x 4' in size

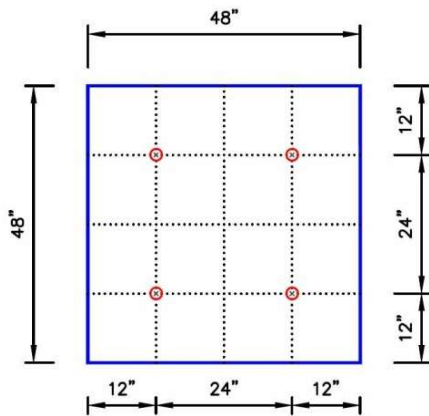

4 Insulation Fasteners & Plates

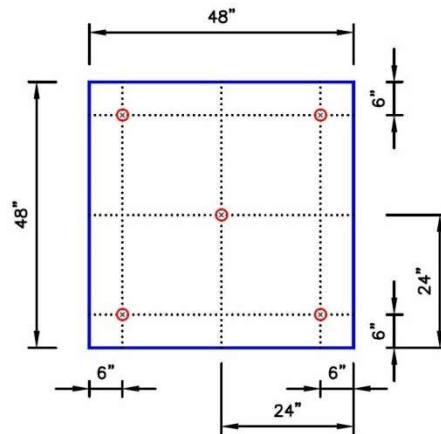

5 Insulation Fasteners & Plates

Only FM 1-90 for:

2" Polyiso MP-H/Versicore or SecurShield

1/2" SecurShield HD Plus

5/8" DensDeck Prime, DensDeck StormX Prime or Securock

5/8" DEXcell

5/8" DEXcell FA

5/8" DEXcell Cement Roof Board

5/8" DEXcell FA VSH

Only FM 1-90 for:

1/2" Securock

1/2" DEXcell

1/2" DEXcell FA

1-1/2" Polyiso MP-H/Versicore (base layer fastened only)

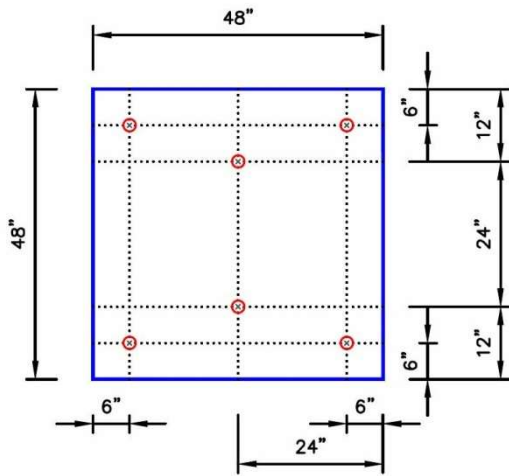

6 Insulation Fasteners & Plates

FM 1-90 for:

1/4" DensDeck Prime

FM 1-75 for:

1/4" Securock

1/4" DEXcell

1/4" DEXcell FA

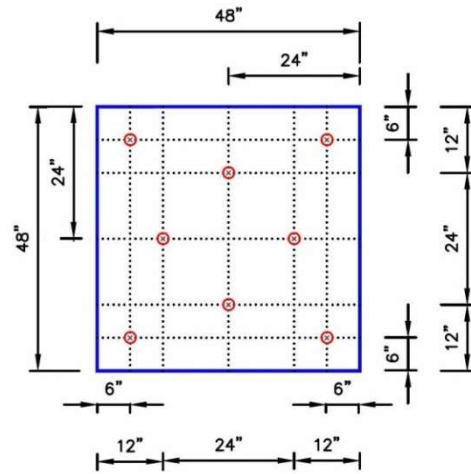

8 Insulation Fasteners & Plates

FM 1-90 for all except:

1" Polyiso MP-H/Versicore
(recover only)

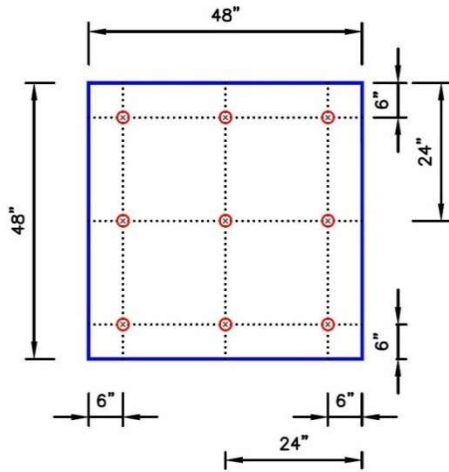

9 Insulation Fasteners & Plates

Fastening pattern should only be used when required by FM for perimeter or corner enhancement or required by Versico for issuance of extended wind speed warranty.

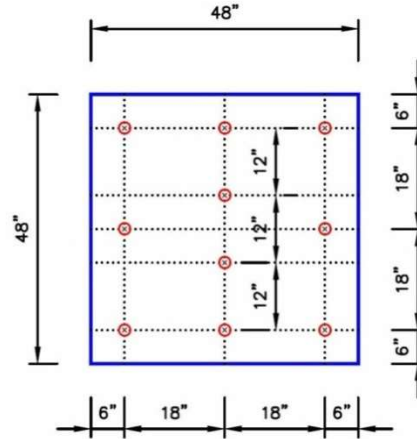

10 Insulation Fasteners & Plates

FM 1-150 for:

2" Polyiso MP-H/Versicore (EPDM, TPO and VersiFleece)

1/2" Securock (EPDM, TPO and VersiFleece)

FM 1-135 for:

2" Polyiso MP-H/Versicore (PVC)

FM 1-105 for:

1/2" DensDeck Prime

FM 1-90 for:

1-1/2" Polyiso MP-H/Versicore (Recover)

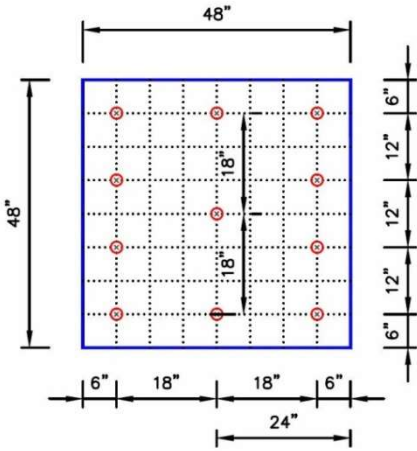

11 Insulation Fasteners & Plates

Fastening pattern should only be used when required by FM for perimeter or corner enhancement or required by Versico for issuance of extended wind speed warranty.

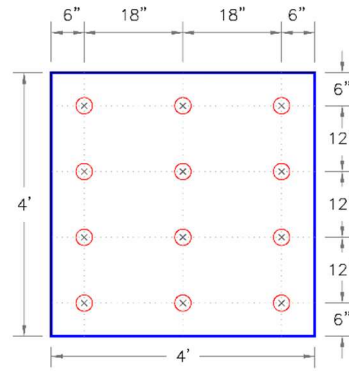

12 Insulation Fasteners & Plates

Fastening pattern should only be used when required by FM for perimeter or corner enhancement or required by Versico for issuance of extended wind speed warranty.

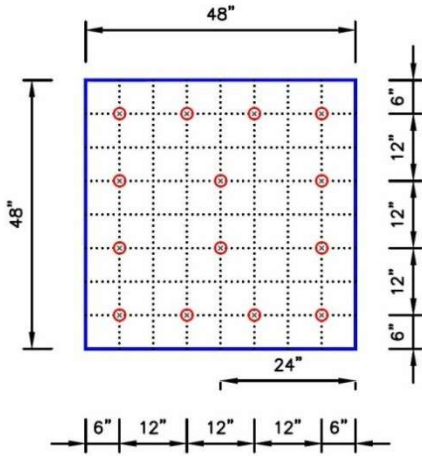

14 Insulation Fasteners & Plates

Fastening pattern should only be used when required by FM for perimeter or corner enhancement or required by Versico for issuance of extended wind speed warranty.

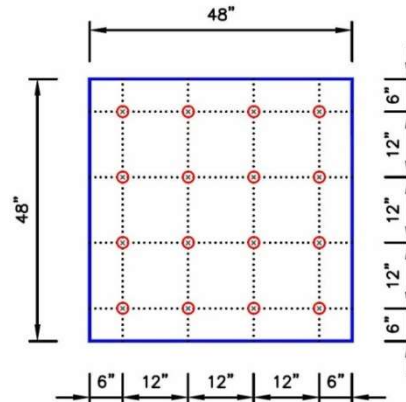

16 Insulation Fasteners & Plates

FM I-285 for:

1/2" DensDeck Prime (VersiFleece)

FM 1-225 for:

2" SecurShield

2" Polyiso MP-H/Versicore (VersiFleece)

1/2" Securock

1/2" DEXcell, 1/2" DEXcell FA

FM 1-195 for:

2" Polyiso MP-H/Versicore (EPDM and TPO)

Insulation Patterns for boards 4' x 8' in size

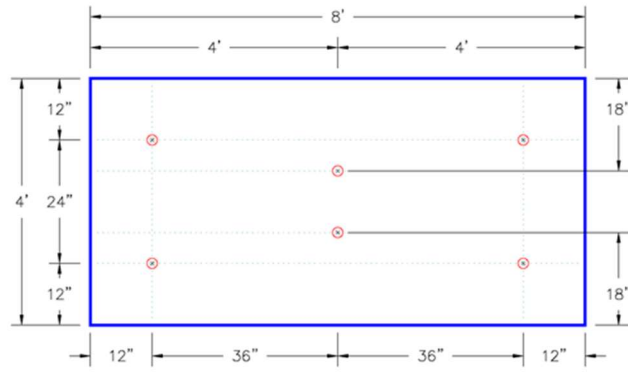

6 Insulation Fasteners & Plates

FM 1-75 for:

1/2" Securock (with InsulTite fasteners and SecurFAST Plates)

1/2" DEXcell or 1/2" DEXcell FA

FM 1-90 for:

5/8" Securock (with InsulTite fasteners and SecurFAST Plates)

5/8" DEXcell, 5/8" DEXcell FA, 5/8" DEXcell Cement Roof Board, or 5/8" DEXcell FA VSH

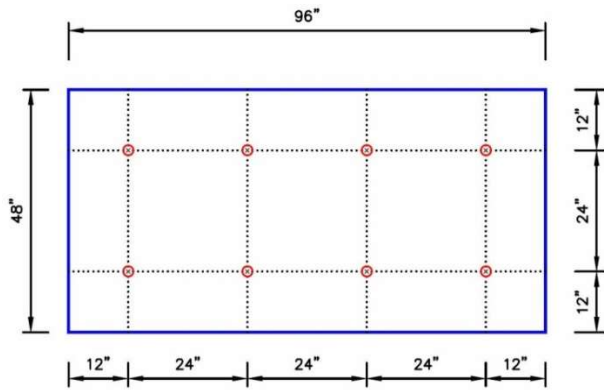

8 Insulation Fasteners & Plates

FM 1-90 for:

2" Polyiso MP-H/Versicore/Versicore NH/Versicore RL or SecurShield

1/2" SecurShield HD Plus

3/8" or 1/2" Securock (with InsulFAST fasteners and SecurFAST Plates)

1/2" DEXcell

1/2" DEXcell FA

5/8" DensDeck Prime, DensDeck StormX Prime or Securock

5/8" DEXcell, 5/8" DEXcell FA, 5/8" DEXcell Cement Roof Board, or 5/8" DEXcell FA VSH

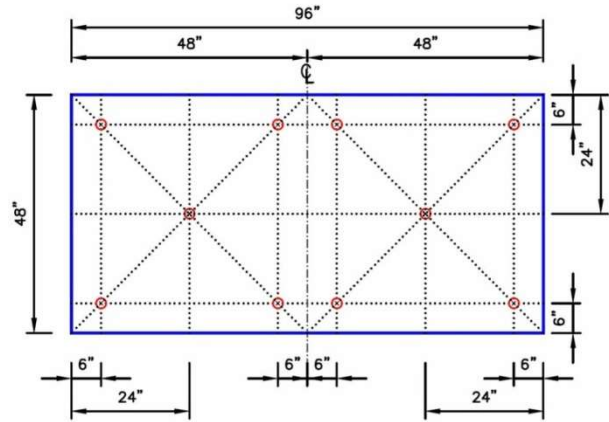

10 Insulation Fasteners & Plates

FM 1-90 for:

1/2" Securock

1-1/2" Polyiso MP-H/Versicore/Versicore NH/Versicore RL (base layer fastened only)

1/2" DEXcell

1/2" DEXcell FA

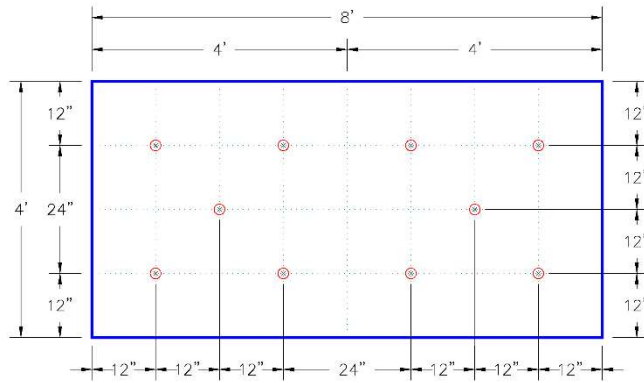

10 Insulation Fasteners & Plates

FM 1-90 for:

1/4" Securock (with InsulTite fasteners and SecurFAST Plates)

1/4" DEXcell, 1/4" DEXcell FA

1/2" DensDeck Prime

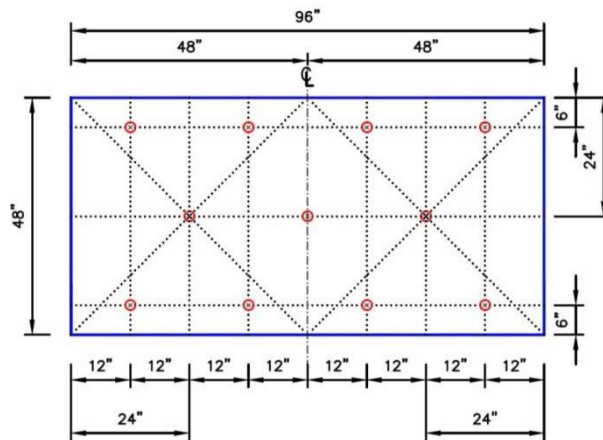

11 Insulation Fasteners & Plates

FM 1-90 for:

1-1/2" Polyiso MP-H/Versicore/Versicore NH/Versicore RL

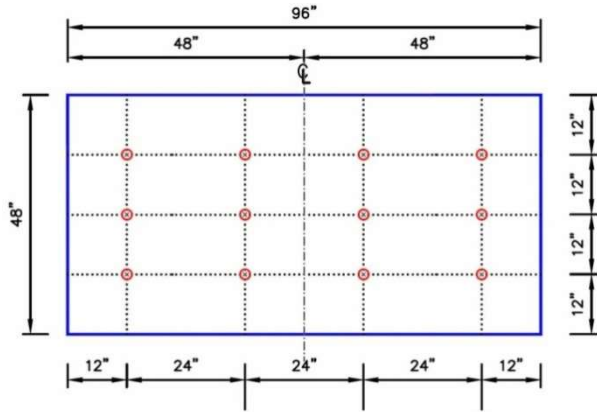

12 Insulation Fasteners & Plates

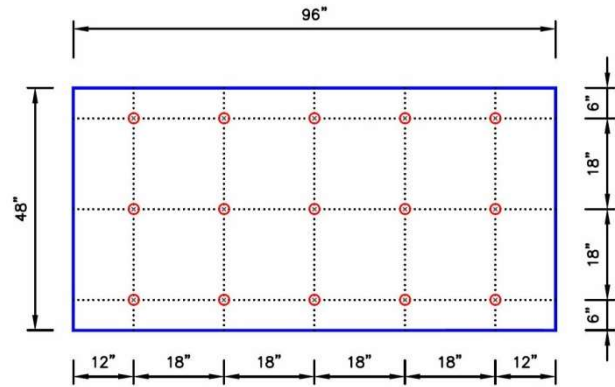

15 Insulation Fasteners & Plates

FM 1-90 for:

1/4" DensDeck Prime

FM 1-75 for:

1/4" Securock

1/4" DEXcell, 1/4" DEXcell FA

Fastening pattern should only be used when required by FM for perimeter or corner enhancement or required by Versico for issuance of extended wind speed warranty.

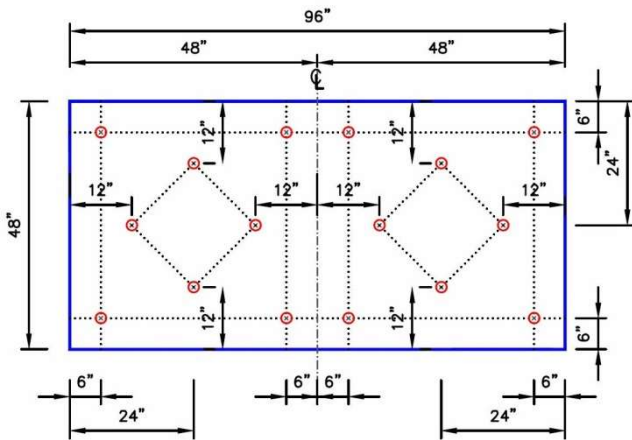

16 Insulation Fasteners & Plates

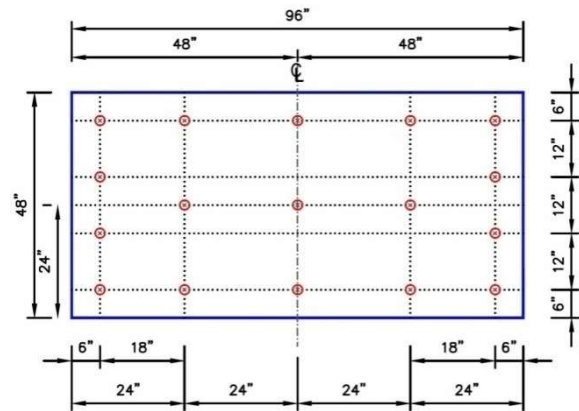

17 Insulation Fasteners & Plates

FM 1-90 for all except:

1" Polyiso MP-H/Versicore/Versicore NH/Versicore RL (Recover Only)

FM 1-105 for:

7/16" OSB (EPDM)

FM 1-150 for:

7/16" OSB (TPO and VersiFleece)

FM-120 for:

7/16" OSB (PVC)

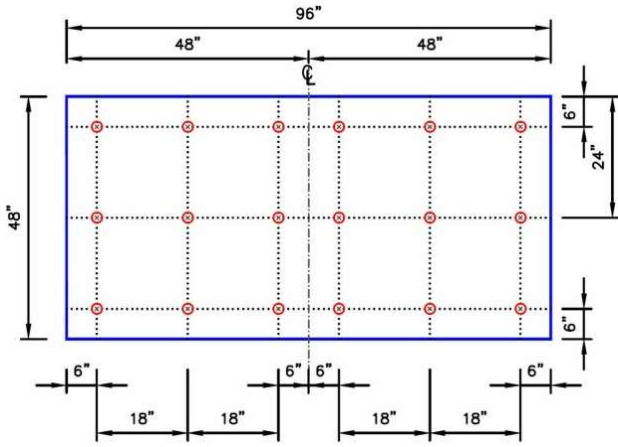

18 Insulation Fasteners & Plates

Fastening pattern should only be used when required by FM for perimeter or corner enhancement or required by Versico for issuance of extended wind speed warranty.

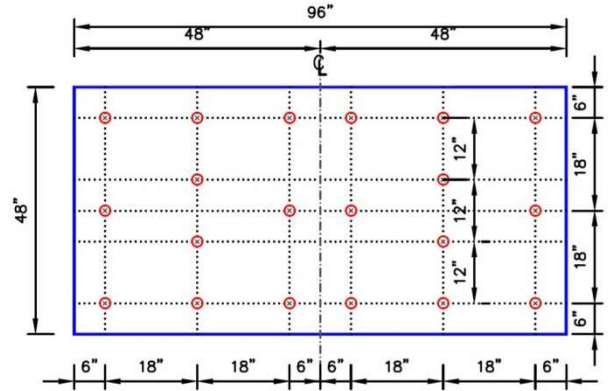

20 Insulation Fasteners & Plates

FM 1-150 for:

1-1/2" VersiCore HD Composite

2" Polyiso MP-H/Versicore/Versicore NH/Versicore RL (EPDM, TPO and VersiFleece) VersiCore HD Composite RL

1/2" Securock (EPDM, TPO and VersiFleece)

FM 1-135 for:

2" Polyiso MP-H/Versicore/Versicore NH/Versicore RL (PVC)

FM 1-105 for:

1/2" DensDeck Prime

FM 1-90 for:

1" Polyiso MP-H/Versicore/Versicore NH/Versicore RL (Recover)

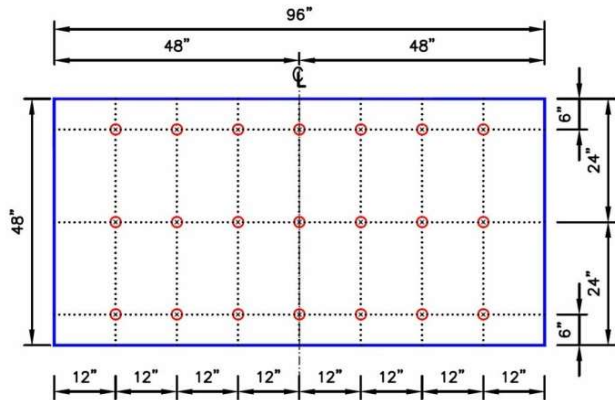

21 Insulation Fasteners & Plates

Fastening pattern should only be used when required by FM for perimeter or corner enhancement or required by Versico for issuance of extended wind speed warranty.

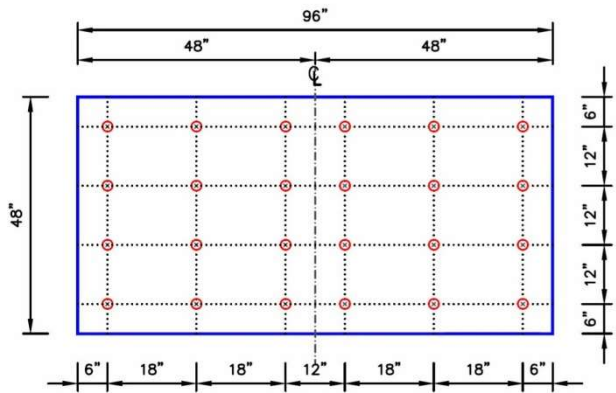

24 Insulation Fasteners & Plates

Fastening pattern should only be used when required by FM for perimeter or corner enhancement or required by Versico for issuance of extended wind speed warranty.

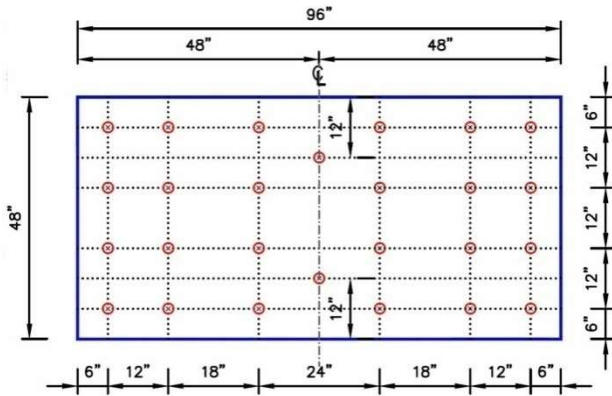

26 Insulation Fasteners & Plates

Fastening pattern should only be used when required by FM for perimeter or corner enhancement or required by Versico for issuance of extended wind speed warranty.

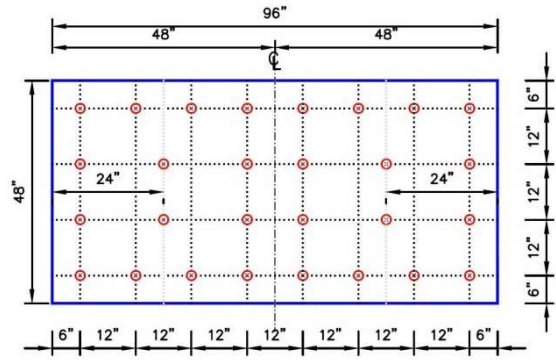

28 Insulation Fasteners & Plates

Fastening pattern should only be used when required by FM for perimeter or corner enhancement or required by Versico for issuance of extended wind speed warranty.

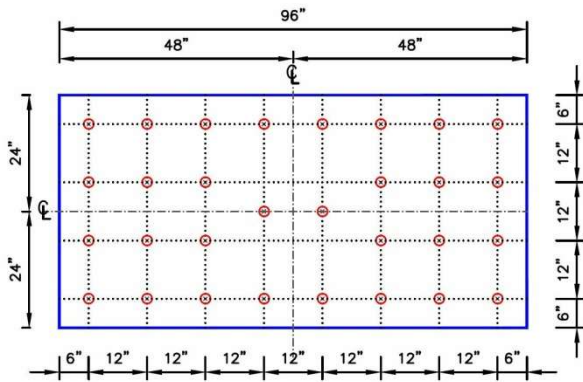

30 Insulation Fasteners & Plates

Fastening pattern should only be used when required by FM for perimeter or corner enhancement or required by Versico for issuance of extended wind speed warranty.

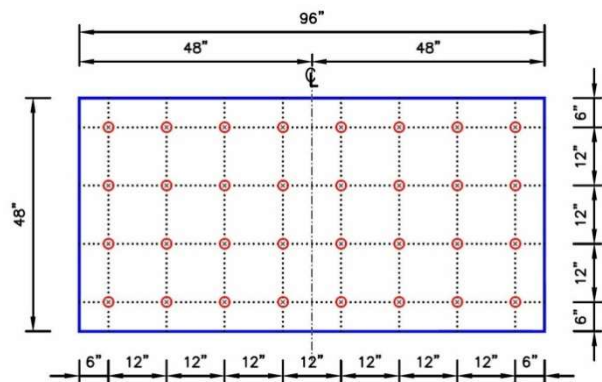

32 Insulation Fasteners & Plates

FM 1-225 for:

2" SecurShield

1/2" Securock

2" Polyiso MP-H/Versicore/Versicore NH/Versicore RL (VersiFleece)

FM 1-195 for:

2" Polyiso MP-H/Versicore/Versicore NH/Versicore RL (EPDM and TPO)

FM 1-285 for:

1/2" DensDeck Prime (VersiFleece)

Insulation Patterns for boards 4' x 12' in size.

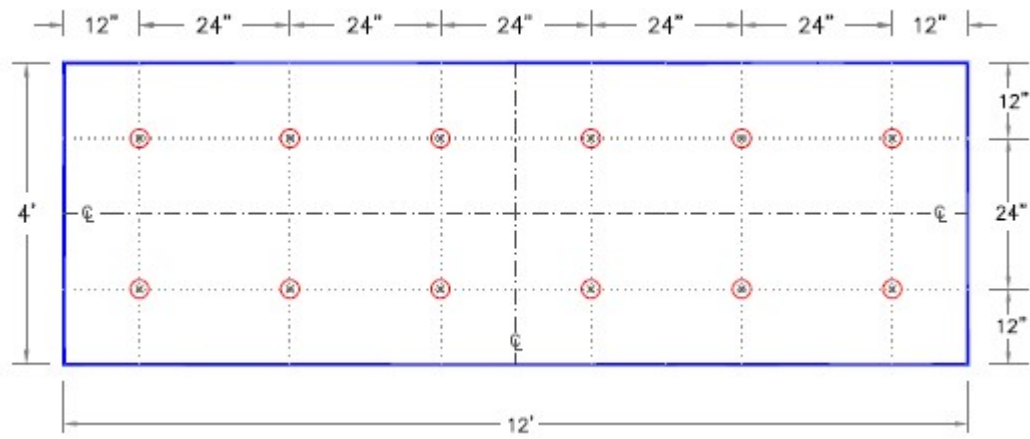

12 Insulation Fasteners & Plates

FM 1-90 for:

2" Polyiso MP-H/Versicore/Versicore NH/Versicore RL

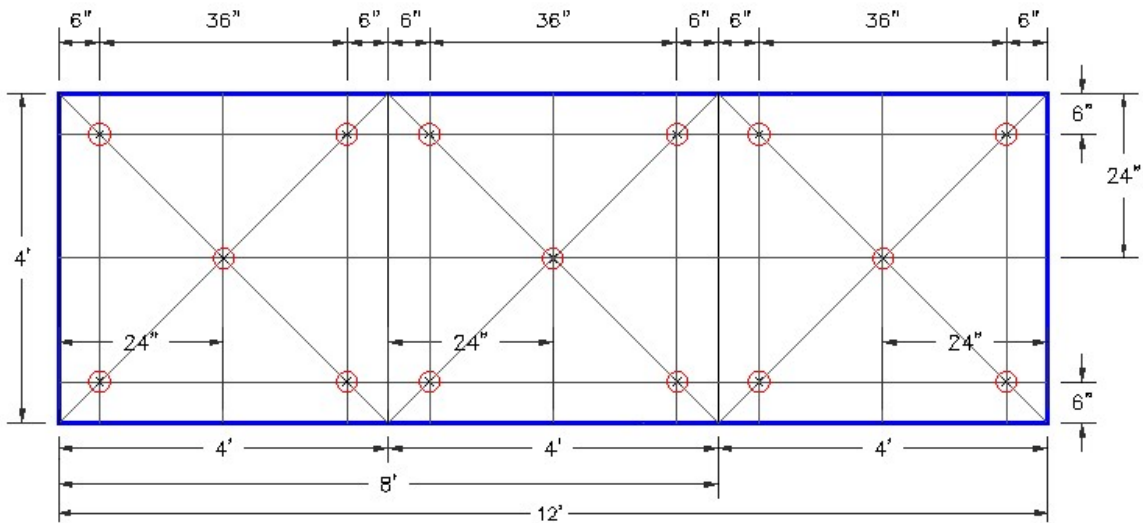

15 Insulation Fasteners & Plates

FM 1-90 for:

1-1/2" Polyiso HP-H/InsulBase/InsulBase NH/InsulBase RL (Base layer fastened only)

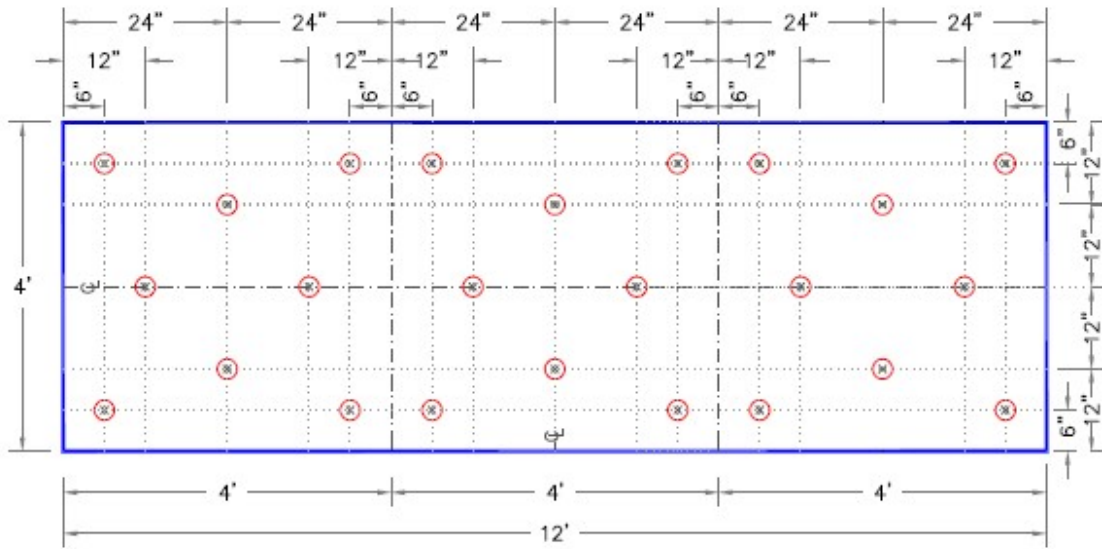

24 Insulation Fasteners & Plates

FM 1-90 for all except:

1" Polyiso MP-H/Versicore/Versicore NH/Versicore RL (Recover Only)

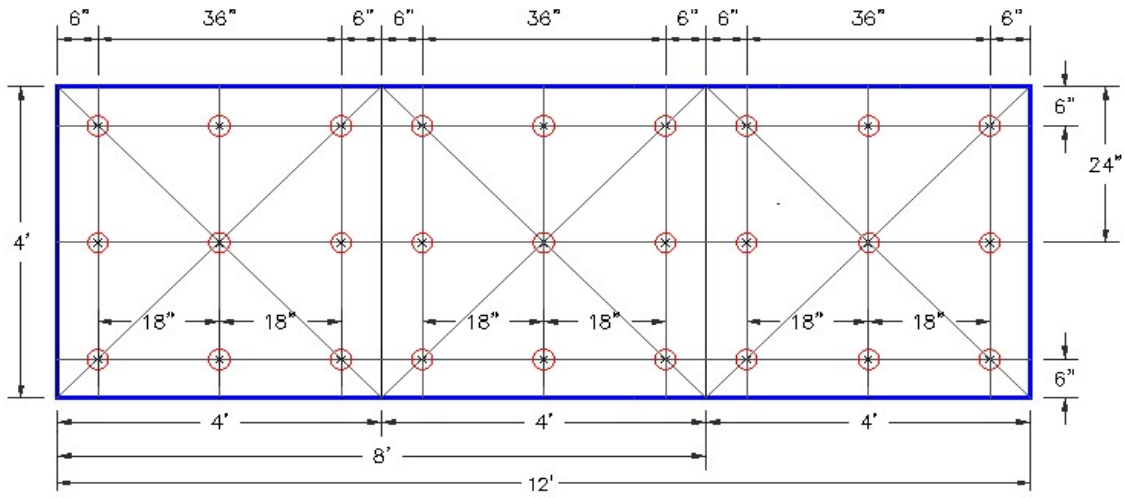

27 Insulation Fasteners & Plates

Fastening pattern should only be used when required by FM for perimeter or corner enhancement or required by Carlisle for issuance of extended wind speed warranty.

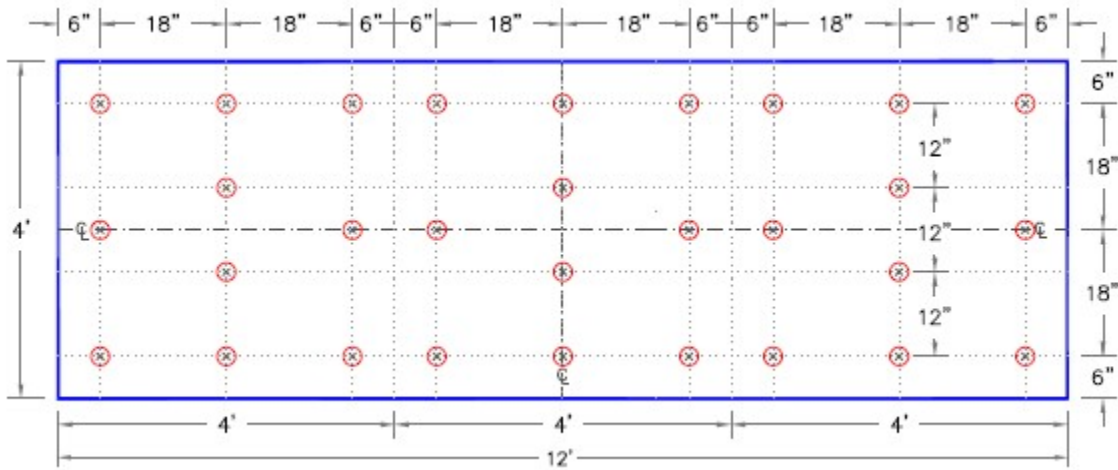

30 Insulation Fasteners & Plates

FM 1-150 for:

2" Polyiso MP-H/Versicore/Versicore NH/Versicore RL (EPDM, TPO and VersiFleece) VersiCore HD Composite RL

FM 1-135 for:

2" Polyiso MP-H/Versicore/Versicore NH/Versicore RL (PVC)

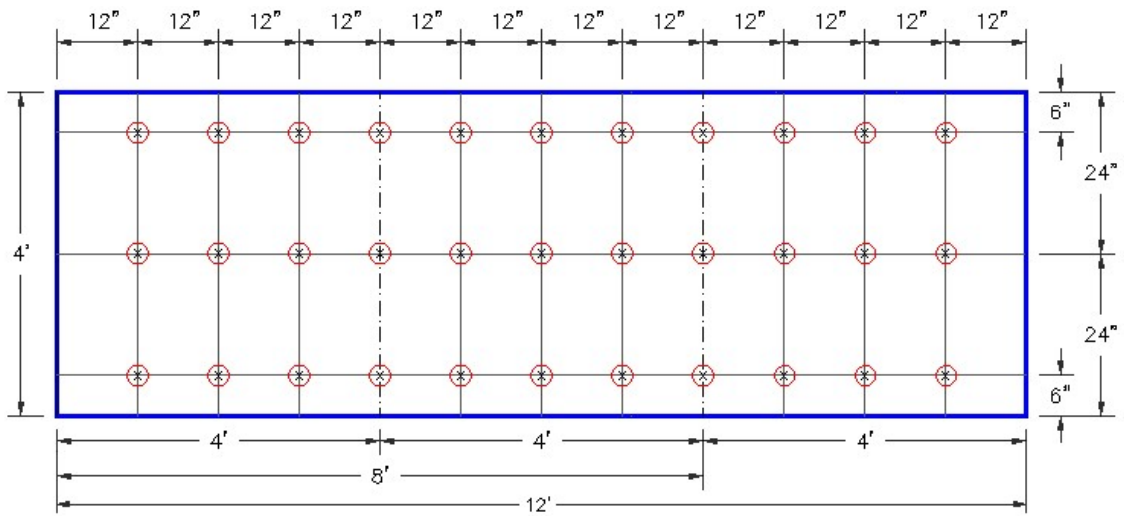

32 Insulation Fasteners & Plates

Fastening pattern should only be used when required by FM for perimeter or corner enhancement or required by Carlisle for issuance of extended wind speed warranty.

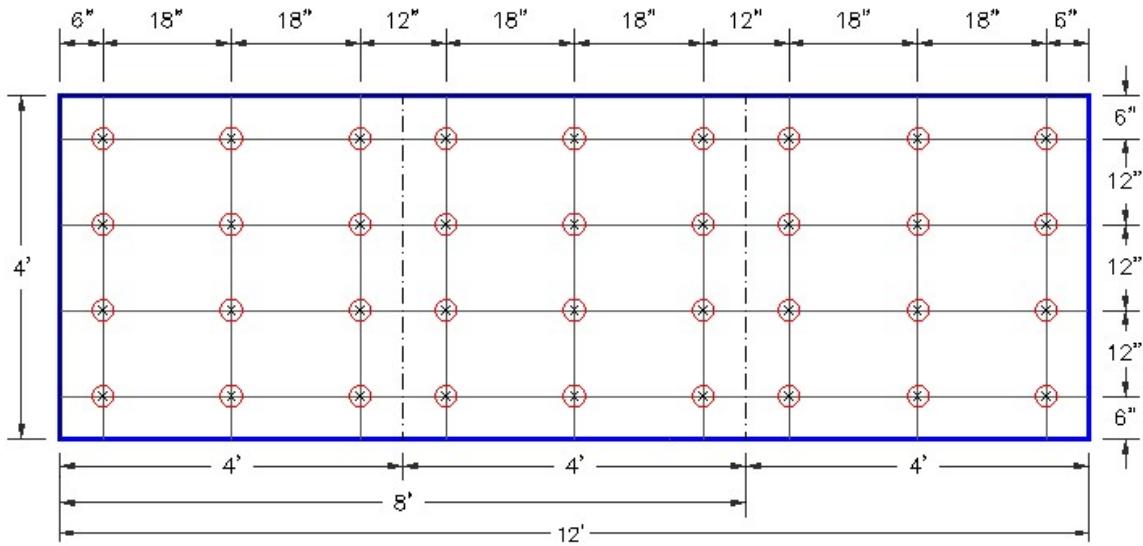

36 Insulation Fasteners & Plates

Fastening pattern should only be used when required by FM for perimeter or corner enhancement or required by Carlisle for issuance of extended wind speed warranty.

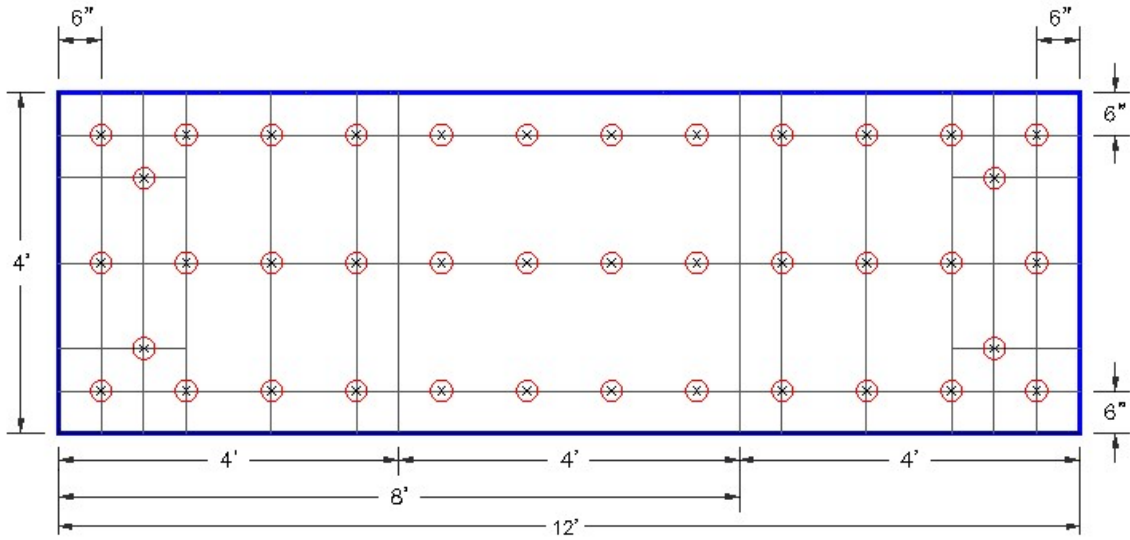

39 Insulation Fasteners & Plates

Fastening pattern should only be used when required by FM for perimeter or corner enhancement or required by Carlisle for issuance of extended wind speed warranty

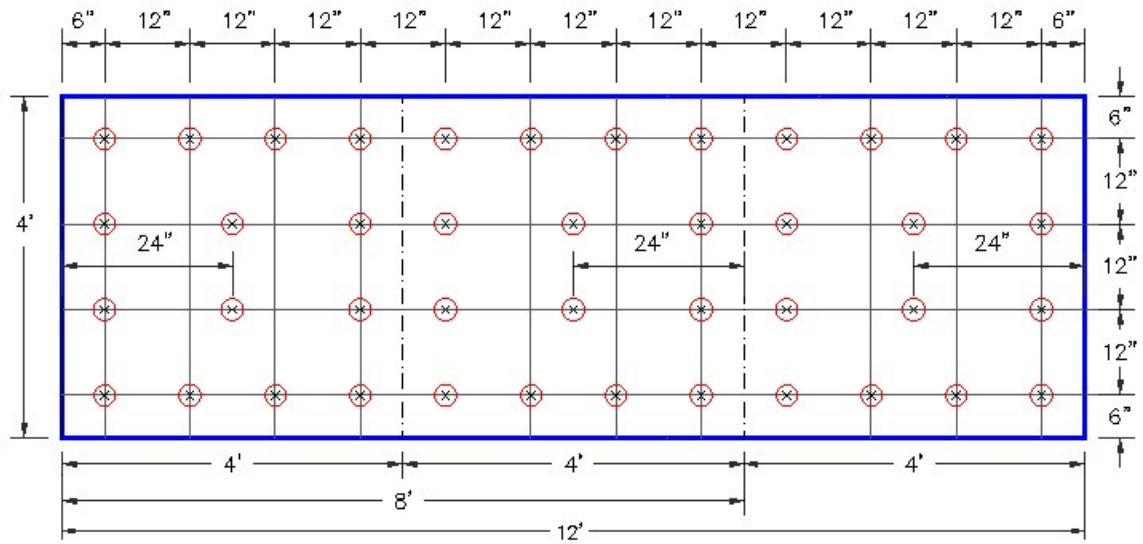

42 Insulation Fasteners & Plates

Fastening pattern should only be used when required by FM for perimeter or corner enhancement or required by Carlisle for issuance of extended wind speed warranty.

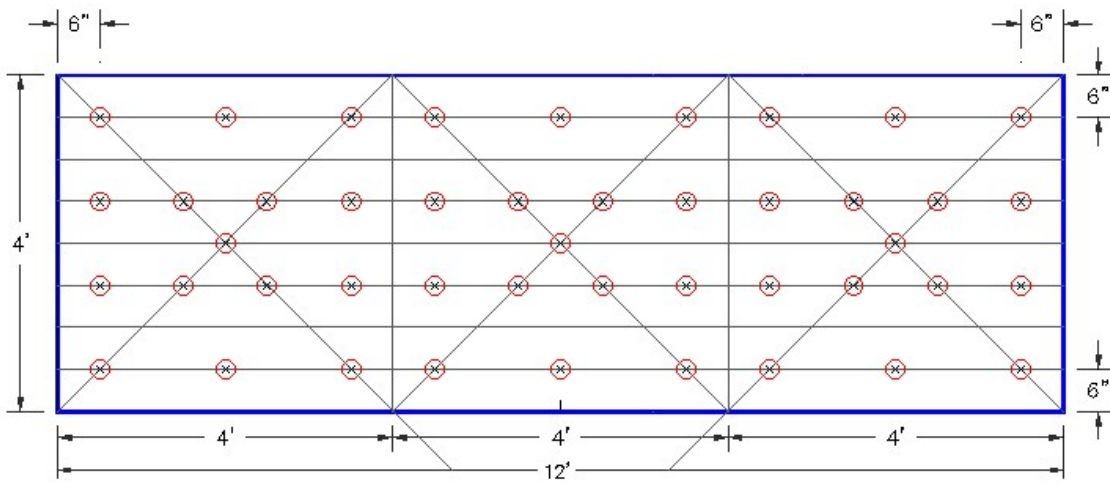

45 Insulation Fasteners & Plates

Fastening pattern should only be used when required by FM for perimeter or corner enhancement or required by Carlisle for issuance of extended wind speed warranty.

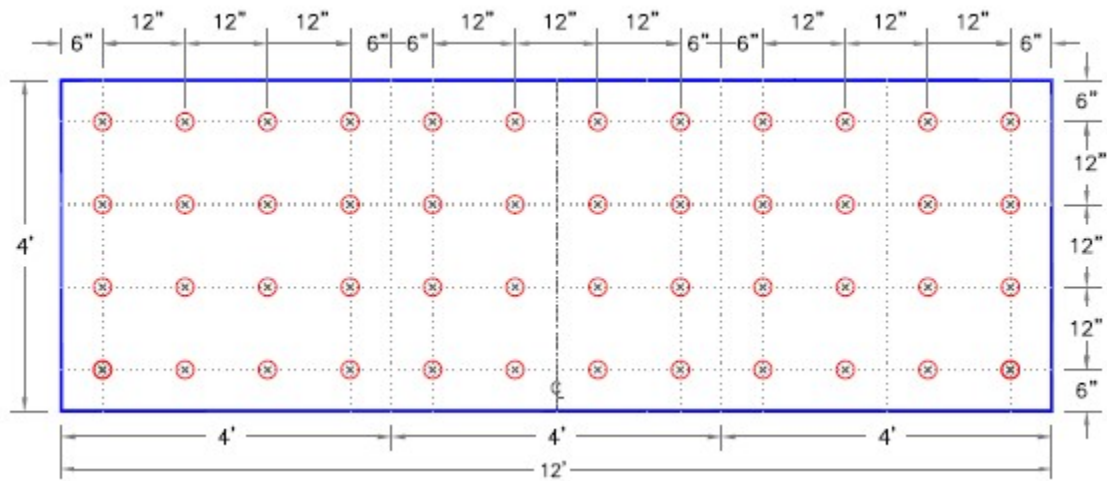

48 Insulation Fasteners & Plates

FM 1-225 for:

2" Polyiso MP-H/Versicore/Versicore NH/Versicore RL (VersiFleece)

FM 1-195 for:

2" Polyiso MP-H/Versicore/Versicore NH/Versicore RL (EPDM and TPO)

Copyright 2026 Versico

Versico, VersiCore and VersiFleece are Trademarks of Versico

Securock is a Trademark of USG Corporation

DensDeck, DensDeck Prime and DensDeck StormX Prime are Trademarks of Georgia-Pacific Gypsum LLC

DEXcell is a trademark of Gold Bond Building Products, LLC

This specification represents the applicable information available at the time of its publication. Owners, specifiers and Versico authorized roofing contractors should consult Versico or their Versico Independent Sales Representative for any information, which has subsequently been made available.

Review the appropriate Versico warranty for specific warranty coverage, terms, conditions and limitations.

DR-06

Withdrawal Resistance Criteria

July 2025

The information contained represents guidelines to address possible requirements as part of the building specification as listed under the Quality Assurance or Performance Article. Versico recommends that the building owner retain a design professional to verify that these guidelines are appropriate.

A. The following chart indicates the appropriate Versico Fastener for use with the referenced roof deck and includes the **minimum pullout** and fastener penetration requirements for membrane/insulation securement on Mechanically Attached Roofing Systems and for insulation attachment on Design “A” Adhered assemblies.

Deck Type	Minimum Pullout, in pounds	Approved Versico Fastener	Minimum Penetration
Steel, 22 gauge or heavier	425 (Mechanically Fastened) (1)	HPV, HPVX Fasteners	¾"
	360 (Adhered)	HPV, HPVX ASAP or InsulTite Fasteners	
Steel, less than 22 gauge	300 (Adhered Only) (2)	HPV, HPVX ASAP or InsulTite Fasteners	
Lightweight Insulating Concrete Over Steel (3)	360	HPV, HPVX ASAP or InsulTite Fasteners (Adhered)	
		HPV, HPVX Fasteners (Mechanically Fastened)	
Structural Concrete, rated 3,000 psi or greater	800	CD-10 or MP 14-10	1"
Wood Planks	360	HPV, HPVX ASAP or InsulTite Fasteners (Adhered)	
		HPV, HPVX Fasteners (Mechanically Fastened)	
OSB Composite and Minimum 15/32" thick Plywood (4)	210 (Mechanically Fastened)	HPV, HPVX Fasteners (Mechanically Fastened)	1"
	210 (Adhered)	HPV or HPX Fastener (Adhered)	
Gypsum	300	GypTec or Lite-Deck	1-1/2" (HP-NTB)
			2" (Lite-Deck)
Cementitious Wood Fiber	300 (Mechanically Fastened) 225 (Adhered Only)	GypTec or Lite-Deck (Adhered)	1-1/2"
<small>(1) Mechanically Fastened Roofing Systems are not permitted over corrugated steel decks, regardless of gauge (2) Mechanically Fastened Roofing Systems are not permitted over corrugated steel decks less than 22 gauge unless in conjunction with lightweight insulating concrete and acceptable pullouts are obtained using HPV fasteners. (3) Fasteners installed through the lightweight insulating concrete into the steel deck below. (4) 7/16" OSB or 5/8" OSB and 15/32" 3-ply plywood or 15/32" 5-ply plywood.</small>			

B. Withdrawal resistance testing may be conducted by an independent laboratory, fastener manufacturer or a representative of Versico on the following roof decks. The results of the pullout tests must be documented and submitted to Versico when the pullout results are less than listed on the previous chart.

1. **Fully Adhered Roofing Systems:**

- a. Cementitious wood fiber or gypsum decks – GypTec or Lite-Deck (gypsum decks only) Fasteners.
- b. Steel decks lighter than 22-gauge - Versico HPV, HPVX, ASAP, InsulTite Fasteners.

- c. Oriented strand board (OSB) decks (less than 5/8" thick) - Versico HPV, HPV-XL.

2. Mechanically Attached Roofing Systems:

- a. Cementitious wood fiber or gypsum decks – GypTec Fastener
 - b. Lightweight insulating concrete over steel decks lighter than 22 gauge - Versico HPV or HPVX Fasteners. Fasteners must penetrate the steel deck below the lightweight concrete.
 - c. Minimum 7/16" thick oriented strand board (OSB) decks - Versico HPV or HPVX Fasteners.
 - d. Minimum 5/8" thick oriented strand board (OSB) decks - Versico HPV or HPVX Fasteners.
 - e. Plywood decks less than 5/8" thick - Versico HPV or HPVX Fasteners.
3. On all other acceptable roof decks, a withdrawal resistance test is strongly recommended.

C. Withdrawal Resistance Procedures

1. On retrofit projects, a core cutter shall be used to remove existing roofing material prior to conducting the withdrawal resistance test (even if the existing roofing membrane is specified to remain). Existing roofing materials will contribute to a higher, misleading pullout value.
2. The following minimum trial fastener samples must be installed and tested over the roof deck at each level:
 - a. For each roof level of 5,000 sq. ft. or less, conduct a minimum of 3 pullouts.
 - b. For each roof level greater than 5,000 sq. ft. and less than 20,000 sq. ft., conduct a minimum of 10 pullouts.
 - c. For each roof level greater than 20,000 sq. ft. and less than 50,000 sq. ft., conduct a minimum of 15 pullouts.
 - d. For each roof level greater than 50,000 sq. ft. and less than 100,000 sq. ft., conduct a minimum of 20 pullouts.
 - e. For each roof level greater than 100,000 sq. ft., conduct a minimum of 1 pullout per each 5,000 sq. ft.

Note: On projects with multiple roof levels, when pullouts are conducted on the main roof level, smaller canopies, overhangs, penthouses, etc., of 1,000 square feet or less will not require pullout tests providing these areas consist of the same decking material as the main roof level.

3. The trial fastener installations should be tested in various locations of the roof deck including roof corners and perimeters (areas parallel to the edge of the roof with a width which is 0.4 times the building height). Designate the test locations on a roof plan and include with the submittals to Versico, when requested.

For building height ≤ 60 ft: .4 x the building height or .1 x the width (whichever is less), but not less than 4% the width.
For buildings > 60 ft: .1 x the width

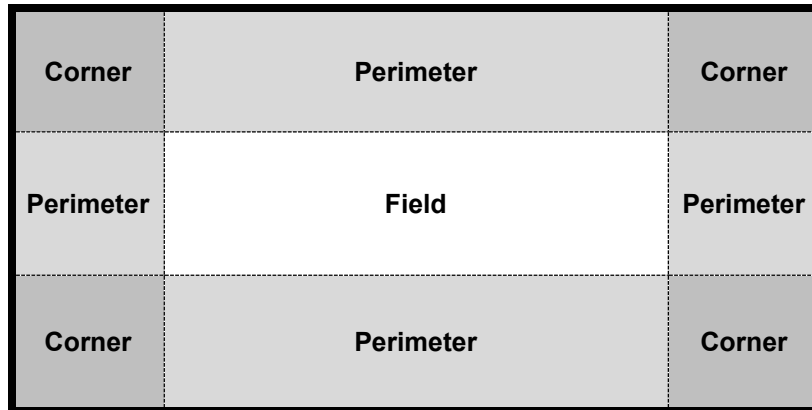

Copyright 2025 Versico

Versico and the Versico logo are Trademarks of Versico

This specification represents the applicable information available at the time of its publication. Owners, specifiers and Versico authorized roofing contractors should consult Versico or their Versico Independent Sales Representative for any information, which has subsequently been made available.

Review the appropriate Versico warranty for specific warranty coverage, terms, conditions and limitations.

CRRC / LEED Information

January 2026

The table below illustrates membrane properties as they pertain to reflectivity, emittance, recyclability and test methods. The data can be referenced when compliance with CRRC standards and LEED pre-requisites are required. Other LEED compliant information could be obtained by contacting Versico or by consulting www.versico.com. Additional LEED information is contained in various Technical Data Bulletin.

VersiGard (white) EPDM Membranes - VersiWeld TPO Membranes (White/Tan/Gray)

Physical Property	Test Method	VersiGard White	VersiWeld	VersiWeld	VersiWeld
Membrane Color		White	White	Tan	Gray
CRRC – Initial solar reflectance	ASTM C1549	0.76	0.79	0.71	0.46
CRRC – Solar reflectance after 3 years (uncleaned)	ASTM C1549	0.64	0.70	0.64	0.43
CRRC – Initial thermal emittance	ASTM C1371	0.90	0.90	0.86	0.89
CRRC – Thermal emittance after 3 years (uncleaned)	ASTM C1371	0.87	0.86	0.87	0.88
LEED – Thermal emittance	ASTM E408	0.90	0.90	0.86	0.89
Solar Reflective Index (SRI) - Initial	ASTM E1980	94	99	86	53
Solar Reflective Index (SRI) – 3 YR	ASTM E1980	77	85	77	48
LEED – Pre-consumer recycled content	-	0%	10%	10%	10%
LEED – Post-consumer recycled content	-	0%	0%	0%	0%
LEED – Manufacturing location	-	Carlisle, PA or Greenville, IL	Senatobia, MS or Tooele, UT	Senatobia, MS or Tooele, UT	Senatobia, MS or Tooele, UT

Note: VersiGard (Black) Membrane: SRI 7; Pre-consumer recycled content 0%; Post-consumer recycled content 3%; Manufacturing Location Carlisle, PA and Greenville, IL.

VersiFlex PVC/KEE HP Membranes (White/Tan/Gray)

Physical Property	Test Method	VersiFlex	VersiFlex	VersiFlex	VersiFlex KEE HP	VersiFlex KEE HP	VersiFlex KEE HP
Membrane Color		White	Tan	Gray	White	Tan	Gray
CRRC – Initial solar reflectance	ASTM C1549	0.86	0.72	0.59	0.87	0.74	0.58
CRRC – Solar reflectance after 3 years (uncleaned)	ASTM C1549	0.63	0.60*	0.49*	0.71*	0.63*	0.50*
CRRC – Initial thermal emittance	ASTM C1371	0.89	0.87	0.89	0.89	0.88	0.88
CRRC – Thermal emittance after 3 years (uncleaned)	ASTM C1371	0.87	0.86*	0.86*	0.87*	0.84*	0.84*
LEED – Thermal emittance	ASTM E408	0.89	0.87	0.89	0.89	0.88	0.88
Solar Reflective Index (SRI) - Initial	ASTM E1980	108	88	70	110	90	69
Solar Reflective Index (SRI) – 3 YR	ASTM E1980	75	71*	56*	87*	71*	56*
LEED – Pre-consumer recycled content	-	10%	10%	10%	10%	10%	10%
LEED – Post-consumer recycled content	-	0%	0%	0%	0%	0%	0%
LEED – Manufacturing location	-	Greenville, IL	Greenville, IL	Greenville, IL	Greenville, IL	Greenville, IL	Greenville, IL

* CRRC Rapid Ratings: These are interim laboratory-aged values that simulate weathered values. These values will be replaced with the measured three-year aged values upon completion of the weathering process. SRI values calculated using Rapid Ratings may change once the aged rating replaces the interim rating.

Copyright 2026 Versico

Versico, VersiGard, VersiWeld and VersiFlex are trademarks of Versico

This Design Reference represents the applicable information available at the time of its publication. Owners, specifiers and Versico authorized roofing contractors should consult Versico or their Versico Independent Sales Representative for any information that has subsequently been made available.

Review the appropriate Versico Warranty for specific warranty coverage, terms, conditions and limitations.

Wood Nailers and Securement Criteria
(Factory Mutual Loss Prevention Data Sheet 1-49)

January 2026

The information contained represents guidelines to address possible requirements as part of the building specification as listed under the Quality Assurance or Performance Article. Versico recommends that the building owner retain a design professional to verify that these guidelines are appropriate.

One of the most often overlooked details on a roofing system is the attachment method for wood nailers at the perimeter of the roof. Factory Mutual Global (FMG) publishes design recommendations for the attachment of wood nailers to various substrates and for the attachment of perimeter flashing details to wood nailers. This information is contained in Factory Mutual's Property Loss Prevention Data Sheet 1-49. In accordance with that Data Sheet, the information listed below should be referenced when selecting an appropriate perimeter attachment method.

General Criteria

A **horizontal wood nailer** is used to provide an effective substrate for some installation details and for other roof accessories. In addition, it is used to provide solid protection for the edge of the membrane underlayment. Minimum thickness of the nailer must be such that the top of the nailer is flush with the top of the membrane underlayment.

1. The width of the nailers must exceed the width of the metal flange of edgings, scuppers, etc.
2. When treated lumber is specified, it is recommended that only lumber that has been pressure treated with salt preservatives be specified. Lumber treated with any of the wood preservatives such as, Creosote, Pentachlorophenol, Copper Naphthenate and Copper 8-quinolinolate will adversely affect the membrane when in direct contact and are, therefore, **unacceptable**.

If non-treated lumber is to be specified, it must be stored to protect from moisture sources. A seal should be provided between the non-treated lumber and a concrete or gypsum substrate (similar to a sill sealer).

3. Methods used to fasten the nailer vary with building conditions; however, it is essential that secure attachment of durable stock be accomplished. Factory Mutual Loss Prevention Data Bulletin 1-49 (Perimeter Flashing) contains options for the spacing and sizing of fasteners based on the project wind zone.
 4. Wood nailers are not covered by the Versico warranty.
- Wood nailers that are anchored to steel, wood or masonry decking should not be less than 2" X 6" nominal (minimum 1-1/2" X 5-1/2").
 - Wood nailers should be Douglas Fir, Southern Yellow Pine or of wood having similar decay resistant properties.

Attachment to Masonry Walls

When fastening to a masonry wall, a 1/2 inch diameter anchor bolt is placed 48 inches on center at an 8 inch minimum depth (12 inches minimum when masonry walls are composed of lightweight aggregate or cinder) as shown in **Figure 1**. Each anchor bolt is positioned (staggered if the wood nailer is wider than 6 inches) in a block core or air space and tightly filled with concrete to the depth of the bolt.

Note: Plastic parts must not be used with masonry anchors.

FMG has specific requirements concerning filling of cores or voids in the top course of cinder blocks.

For example:

Projects requiring 75-psf or 90-psf ratings - fill the entire top course.

Projects requiring 60-psf ratings - fill only required where anchor bolts are positioned (48 inches on center in the field, 24 inches on center at roof corners).

At outside corners, the fastening density must be increased within the first 8 feet in each direction by positioning anchor bolts 24 inches on center.

An alternate method may be used by installing 3/8 inch diameter anchor bolts spaced 32 inches apart. For outside corners, bolts are fastened 16 inches apart, 8 feet from each side of the corner. If additional wood nailers are needed, refer to **Figure 5** for attachment of additional wood nailers.

Attachment to Steel and Wood Decking

- Penetration of the fasteners should be to the top flutes only. The fasteners must be staggered as shown in **Figure 2**.
- The staggered fastening pattern should be increased within 8 feet from outside corners as shown in **Figure 3A**.
- If the perimeter nailer is to be secured to a steel angle, anchor bolts must be positioned at 48 inch centers as show in **Figure 4**.
- On wood decks, the staggered fastening pattern with galvanized steel screws should be utilized as shown in **Figure 2**.

Caution: Attention should be paid to the FMG requirement which calls for galvanized steel washers (minimum 5/8 inch outside diameter) to be used in conjunction with galvanized screws. This requirement is not recognized in most cases and most often forgotten.

Attachment of Additional Wood Nailers

- When additional wood nailers are required, they must be attached with galvanized nails or lag screws that penetrate into the bottom nailer at 1-1/4 inches using a staggered fastening pattern in two rows at 24 inches apart as shown in **Figure 5**.
- The increased fastening density within 8 feet from outside corners is still required and must comply with **Figure 3**.
- The Data Sheet also contains important information pertaining to attachment of metal fascia/edging especially for those edgings which are shop fabricated.
- Even though not emphasized in the Data Sheet, contractors should examine or question existing conditions to determine if existing wood nailers are attached in compliance with the above criteria. If not, existing wood

nailers should be refastened using one of these options and additional wood nailers must be secured following **Figure 5**.

Projects where Factory Mutual is the insurance underwriter should be reviewed by the local Factory Mutual office for specific criteria.

Since wood nailers are not considered part of the Versico Membrane System Warranty, they are not addressed in depth in the Versico specifications nor inspected by the Versico Field Service Representative. Wood nailers, however, play a major role in the performance of the roofing system and contribute to the wind uplift resistance of the roof edge which is the first line of defense during wind storms.

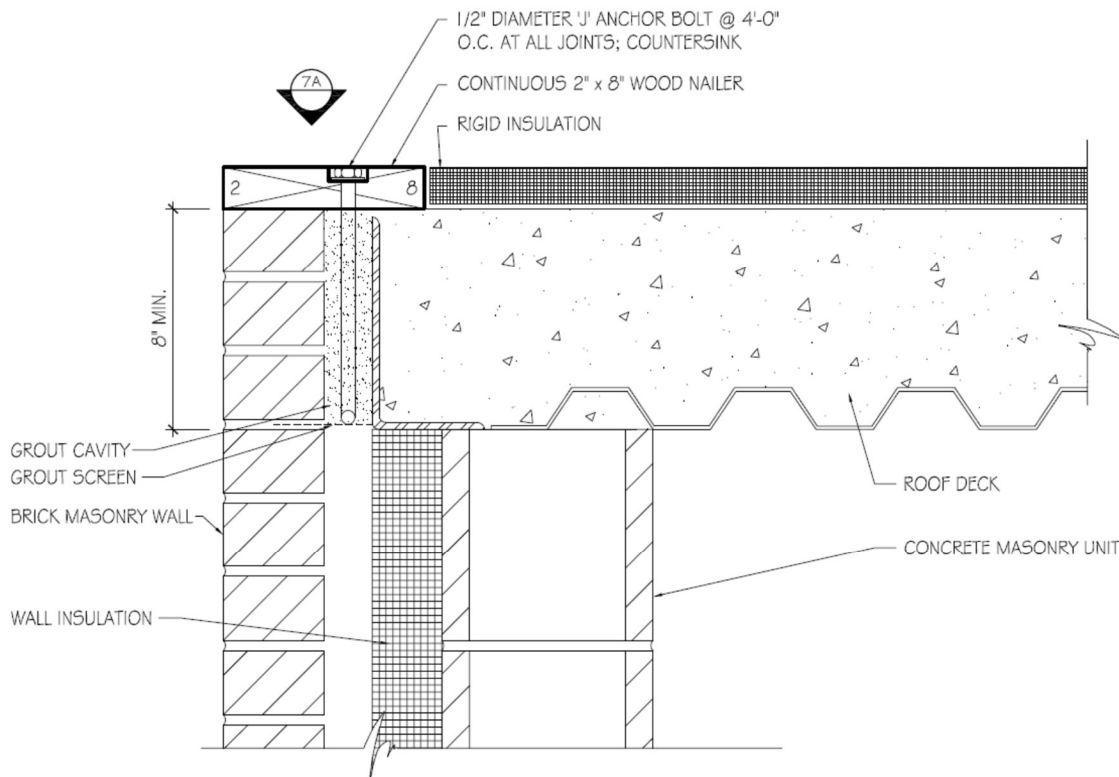

FIGURE 1 - ROOF EDGE WOOD BLOCKING - ANCHOR BOLT SECUREMENT

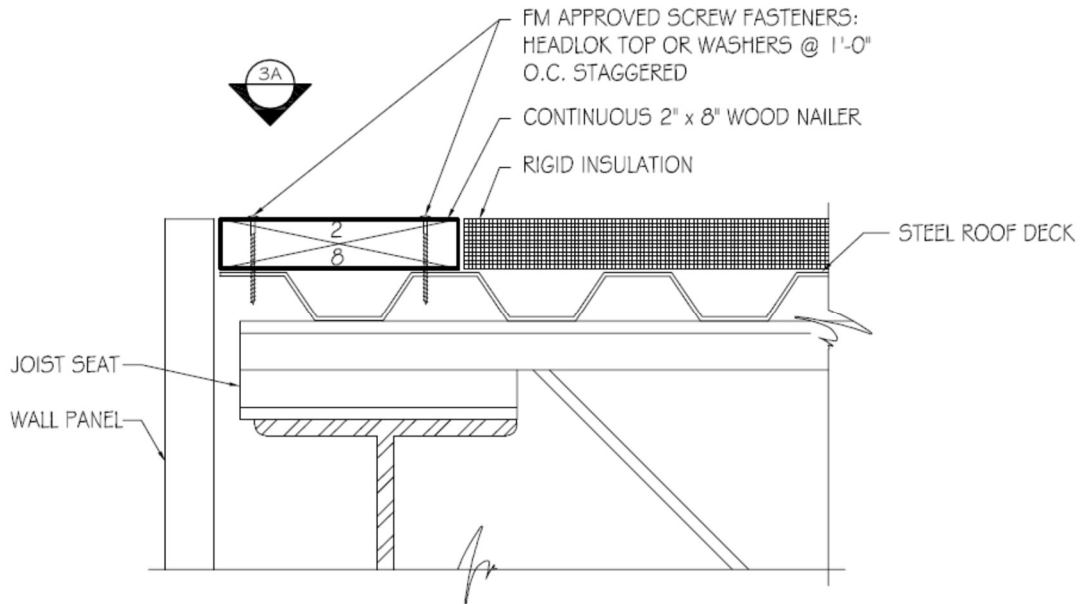

FIGURE 2 - ROOF EDGE WOOD BLOCKING - SCREW FASTENER ANCHORAGE

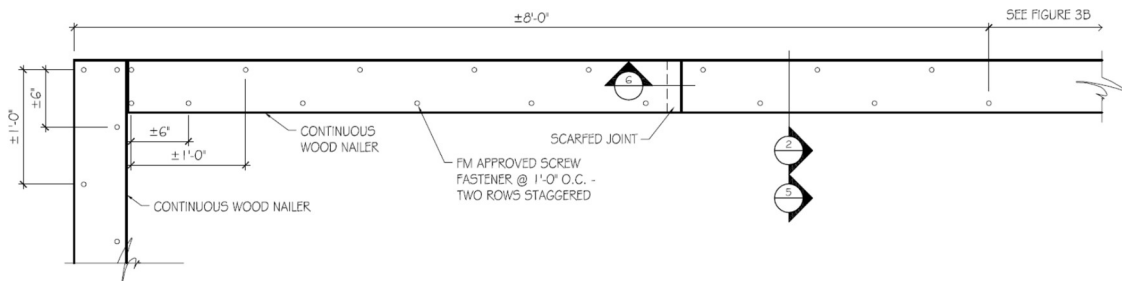

FIGURE 3A - WOOD BLOCKING CORNER ANCHORAGE 8'-0" FROM CORNER

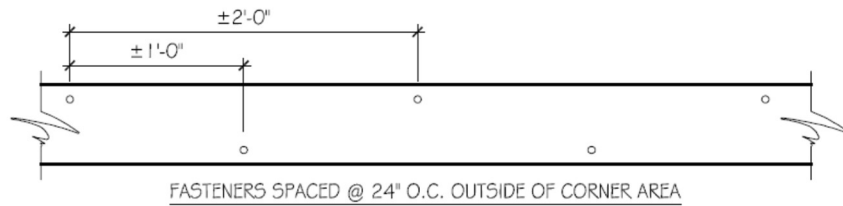

FIGURE 3B - TYPICAL ROOF EDGE WOOD BLOCKING - SCREW FASTENER ANCHORAGE

1/12" = 1'-0"

222/11

NOTES:

1. 3/4" Ø ANCHOR BOLTS @ 48" O.C.
2. AT 8'-0" CORNERS: FASTENING DOUBLED (24" O.C. MAX)

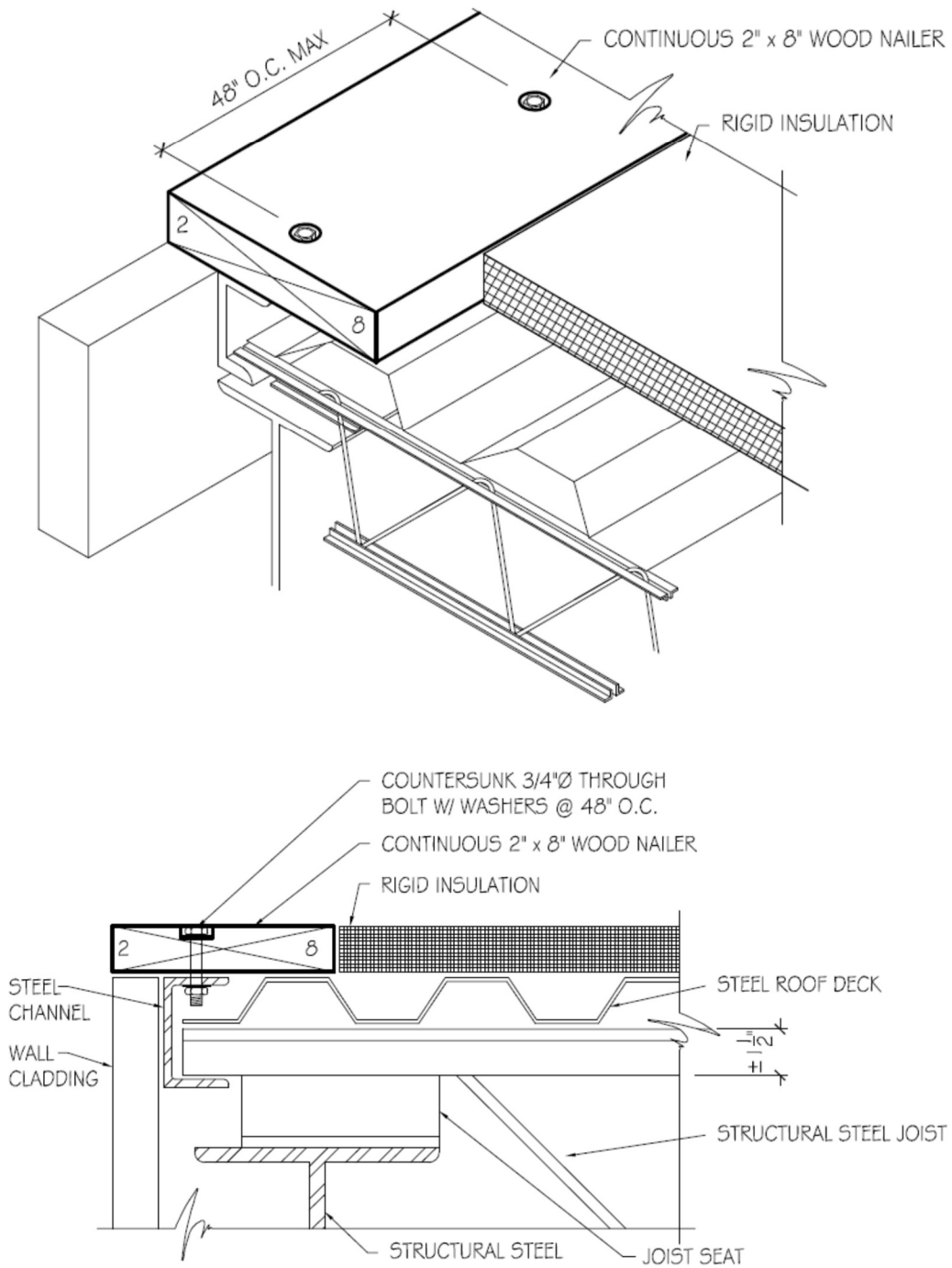

FIGURE 4 - ROOF EDGE WOOD BLOCKING - THROUGH BOLT ANCHORS

NOTES:

1. AT 8'-0" CORNERS, FASTENERS DOUBLED (12" O.C. IN EACH ROW).

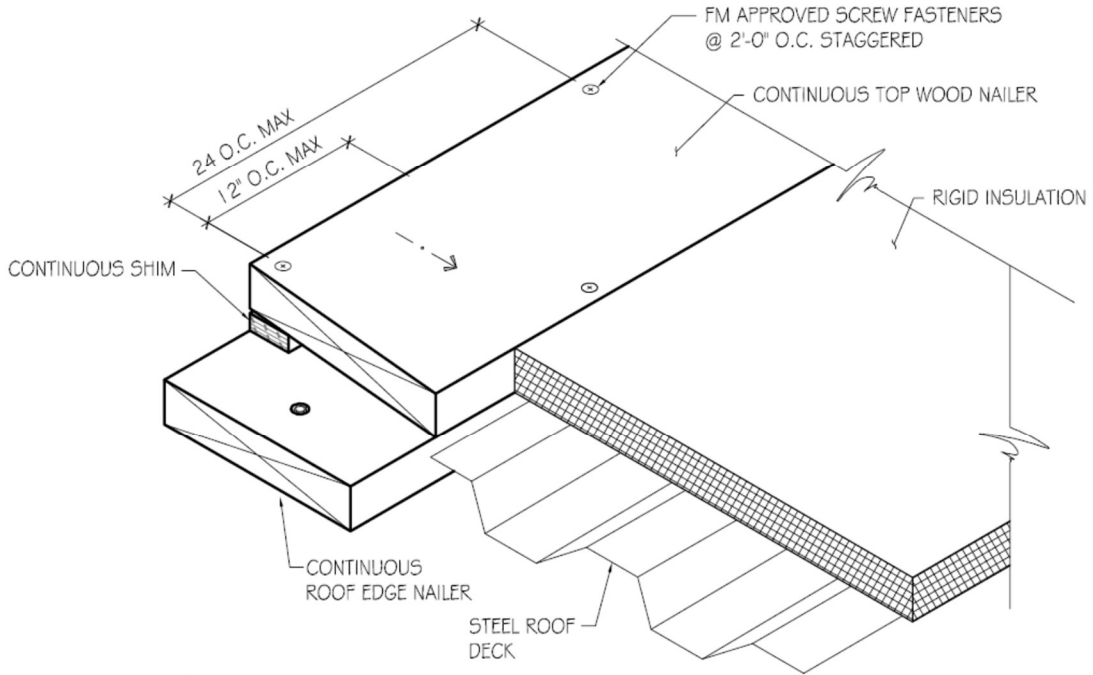

FIGURE 5

STEEL WOOD DECK SCREW FASTENERS AS FOLLOWS:

- 2 x 4 - 2 SCREW FASTENERS
- 2 x 6 - 3 SCREW FASTENERS
- 2 x 8 - 4 SCREW FASTENERS

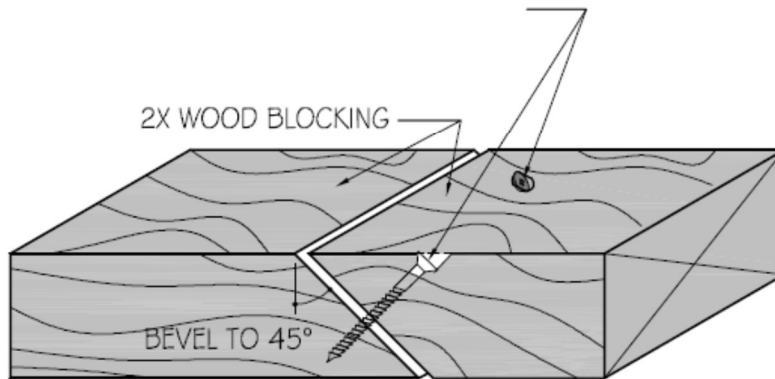

FIGURE 6 - MITERED WOOD JOINT DETAIL

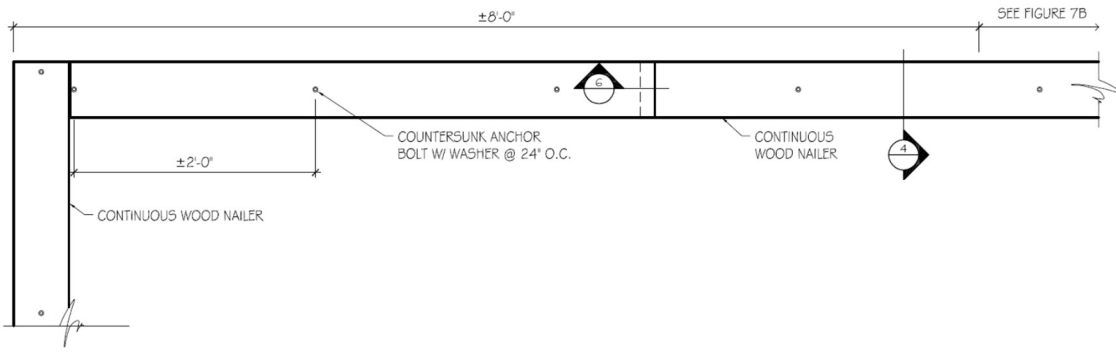

FIGURE 7A - ROOF EDGE WOOD BLOCKING @ CORNER - THROUGH BOLT ANCHORAGE 8'-0" FROM CORNER

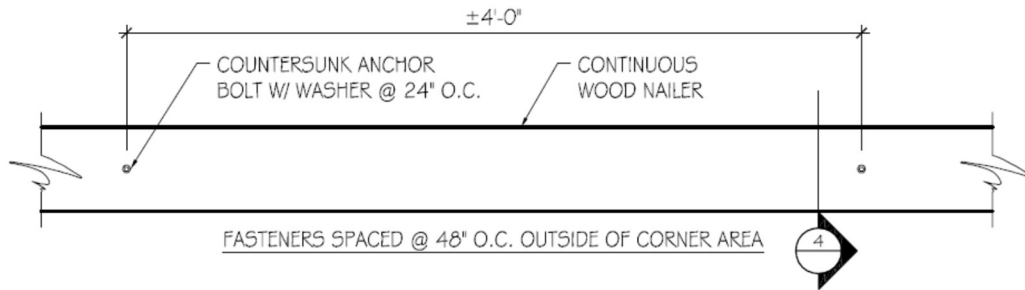

FIGURE 7B - TYPICAL ROOF EDGE WOOD BLOCKING - THROUGH BOLT ANCHORAGE

Copyright 2026 Versico

Versico is a Trademark of Versico

This specification represents the applicable information available at the time of its publication. Owners, specifiers and Versico authorized roofing contractors should consult Versico or their Versico Independent Sales Representative for any information, which has subsequently been made available.

Review the appropriate Versico warranty for specific warranty coverage, terms, conditions and limitations.

DR-09

Considerations for Hail Design

January 2026

The information contained represents guidelines to address possible requirements as part of the building specification as listed under the Quality Assurance or Performance Article. Versico recommends that the building owner retain a design professional to verify that these guidelines are appropriate.

The map below (Figure 1) depicts areas of the United States that are more prone to hail storms. In areas of potential hail, the use of a thicker roofing membrane is recommended to provide greater puncture resistance.

1. VersiFleece 115 or thicker VersiFleece membranes are recommended for areas prone to large hail.
2. Large hail areas may also warrant the use of thicker conventional EPDM, TPO, PVC or KEE HP membrane in conjunction with a rigid membrane underlayment/cover board.
3. To eliminate possible damage of membranes, the substrate below the membrane should be adhered. Insulation fasteners and plates are not recommended for use directly beneath the membrane (except where used for membrane securement).
4. The use PVC membrane is not recommended in Hail Zones greater than 1 inch in diameter, unless specifically approved.

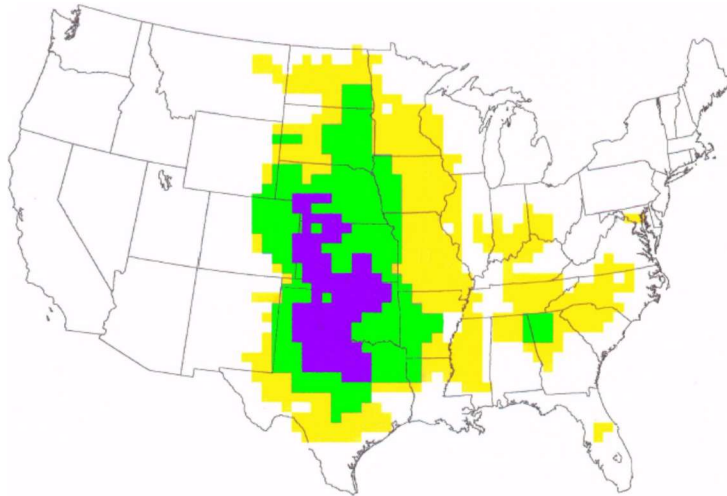





Fig. 1 – U.S. Hail Zone Map

 0.5" – 1.0" Hail

 1.0" – 2.0" Hail

 2.0" – 4.0" Hail

Warranty

- A. A warranty covering leaks caused by hail, maximum 1" diameter with VersiFleece 100 (TPO) or 105-mil (PVC) membrane and maximum 2" diameter with VersiFleece 115-mil (TPO) or 135-mil (PVC) and maximum 3" diameter 135-mil (TPO) membrane, can be issued. Contact Versico for specific information. An additional 1" of hail coverage is available when Flexible DASH adhesive in full coverage or extrusions at 4" on center is utilized with TPO or PVC KEE HP VersiFleece
- B. On projects utilizing VersiFleece 115 membrane, a 5, 10, 15, or 20-year warranty with limited coverage for accidental punctures (up to 16 man-hours per year) is available.
- C. On projects utilizing VersiFleece 135 membrane, a 5, 10, 15, 20, 25 or 30-year warranty with limited coverage for accidental punctures (up to 32 man-hours per year) is available for an additional charge.

Copyright 2026 Versico

Versico and VersiFleece are Trademarks of Versico

This specification represents the applicable information available at the time of its publication. Owners, specifiers and Versico authorized roofing contractors should consult Versico or their Versico Independent Sales Representative for any information, which has subsequently been made available.

Review the appropriate Versico warranty for specific warranty coverage, terms, conditions and limitations.

DR-12

Metal Edging

January 2026

The information contained represents guidelines to address possible requirements as part of the building specification as listed under the Quality Assurance or Performance Article. Versico recommends that the building owner retain a design professional to verify that these guidelines are appropriate.

Pre-Manufactured vs. Shop Fabricated Metal

Introductions

The devastation caused by major hurricanes in Florida as well as the destruction of New Orleans and a portion of the Gulf Coast from Hurricanes Katrina and Rita serve as important reminders of the importance of a strong, impermeable roofing system.

Understandably, the roof edge is one of the more important components of a roofing system. Metal roof edging has a far greater function than merely providing an aesthetic trim at the top of the building – it is a critical component that holds the roofing membrane in place.

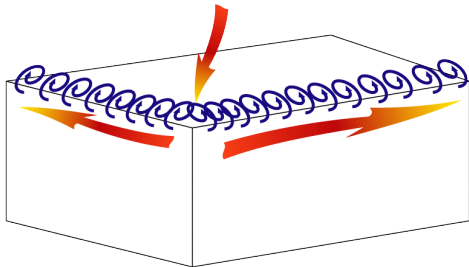

Typical Vortex Patterns on Rooftop Approaching at Corner

- Red Arrows – positive wind pressures acting on the building
- Blue Swirls – negative pressures created by the wind pressure forcing the materials on the edge in an upward and outward direction

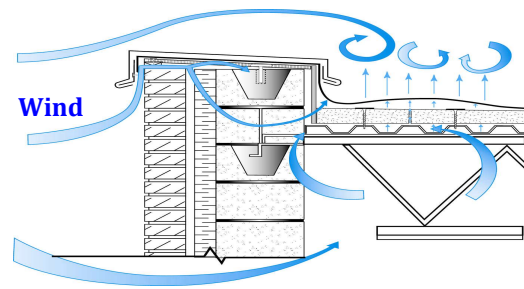

Roof Uplift

The diagram illustrates the wind uplift patterns on a coping and how it moves over and under the coping.

Drawings courtesy of W. P. Hickman Company

Wind Damage Investigation

The **Roofing Industry Committee on Weather Issues (RICOWI)** found roof edges to be number 2 out of a list of 20 roofing issues that needed improvement. In 2006 they released a study that analyzed the 2004 Florida hurricanes (Hurricanes Charley and Ivan). The report found that most of the damage to roofs was caused by failure at the roof perimeter, further confirming the importance of **properly specified and installed roof edge systems**.

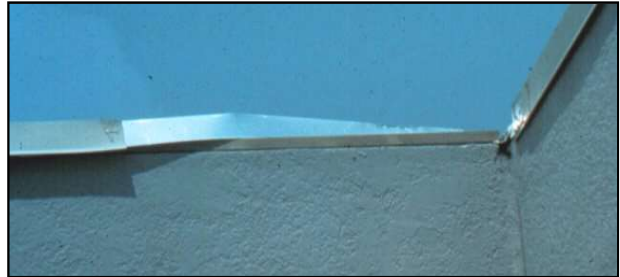

Another key finding from the study included discovery of cleat gauges that were less than those recommended by FM Global 1-49 and ANSI/SPRI ES-1. The committee also found that 95 percent of roof failures were caused by poor workmanship and substituted materials.

Factory Mutual Global (**FMG**) and others have found that over 80% of all roof failures can be attributed directly to failure of the roof edge. It is clear that specifying and installing a roof edge that holds the roof membrane in place as well as looks good is critical to the performance of a building's roof system.

Pre-Manufactured Edging

The performance of pre-manufactured roof edge systems is generally well recognized. Most of these systems are engineered with covers, which tightly snap onto cleats or chairs with pre-punched, slotted fastening holes that assure proper attachment to the roof edge while still allowing for thermal movement. Most of the pre-manufactured systems are tested per ANSI/SPRI ES-1 criteria (now part of the International Building Code) to assure that they resist the calculated wind loads for the project on which they will be used. Additionally, many pre-manufactured roof edge systems are also tested and approved by Factory Mutual Global to further assure their performance.

ES-1

Wind Design Standard for Edge Systems Used with Low Slope Roofing Systems

In 1998 SPRI (Single Ply Roofing Industry, a roofing industry trade association) developed a series of three tests for judging the quality and durability of fascia and coping systems under the **ES-1**, an edge standard for low-slope roofs. The **ES-1** was developed to aid architects, specifiers, and other roofing professionals in ensuring that a quality roof edge is specified and installed.

ES-1 was accepted by the American National Standard Institute (ANSI) as a standard and in 2002 the IBC (International Building Code) included the **ES-1** guidelines into their code. With its inclusion with in the 2003 IBC, **ES-1** has now become building code and a majority of the United States has adopted some version of the IBC. Delaware, Missouri and Nebraska have adopted versions of IBC but may on a Local Government level, refer to the Authority Having Jurisdiction (AHJ) in those states.

So designing a roof edge system that meets **ANSI/SPRI ES-1** Wind Design Standard is not just a good idea; it is the law in many states.

The main reason for the development of **ES-1** was to improve the longevity and safety of low-slope commercial roofs, to protect the building owner's investment by reducing the risk of edge failure, and consequentially roof failure. Basically, **ES-1** provides formulas for calculating the wind load on edges of low-slope roofs and prescribes methodology for testing and evaluating the ability of edge systems to withstand those loads; as a result this ensures wind resistance and long-term performance.

The **ANSI/SPRI ES-1** standard is comprised of three pull-off tests (two tests for fascia and one test for coping) and they are based on the American Society of Civil Engineers' document ASCE-7/02 – *Minimum Design Loads for Buildings and Other Structures*.

- **Test Method RE-1** measures how well the edge secures the perimeter on ballasted and mechanically attached membranes.
- **Test Method ES-2** is a pull-off test for the metal edge flashing. It tests for wind load on the face dimension of the flashing system.
- **Test Method ES-3** tests the strength of the metal coping cap to assure it meets or exceeds calculated design wind pressure. It tests wind load on both the top and back leg dimensions.

How the test is performed – The tests use a pull/release and pull/release method rather than one continuous pull. This allows for a realistic simulation of wind, which acts on a building in periodic gusts rather than one long, continuous gust.

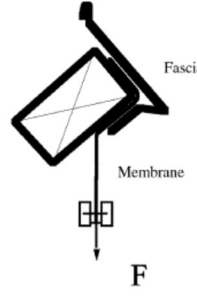
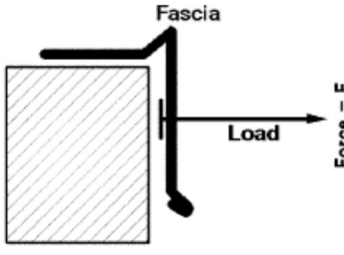
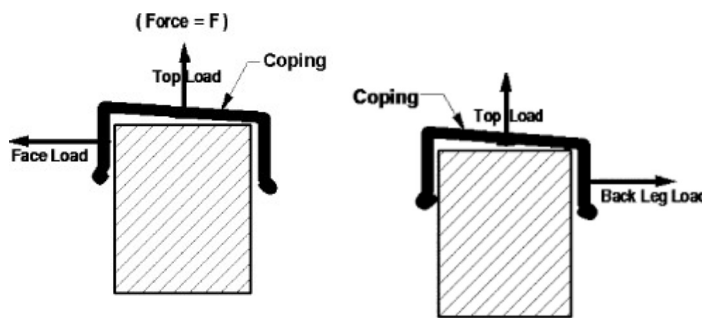
<p>Roof Edge Test RE-1</p> <ul style="list-style-type: none"> • A static test with a 100 lb. load every foot • The membrane is pulled at a 45° angle to the roof deck to simulate a billowing membrane • The termination must withstand a minimum force of 100 lbs./foot • Failure is defined as any event that allows the membrane to come free of the edge termination or the termination to come free. 	 <p>The diagram shows a cross-section of a roof edge. A membrane is attached to the roof deck and is being pulled downwards and outwards at a 45-degree angle. A force 'F' is applied to the membrane. The fascia is shown above the membrane.</p>
<p>Roof Edge Test RE-2</p> <ul style="list-style-type: none"> • Determines the maximum load at failure • Failure is the loss of securement of any component of the roof edge system. 	<p>Fascia Blow-Off Test Set Schematic (Force at Failure x Face Area = Blow-off Resistance)</p>  <p>The diagram shows a cross-section of a roof edge. A fascia is attached to the roof deck. A load is applied to the fascia, pulling it away from the roof deck. The force is labeled 'Force = F'.</p>
<p>Roof Edge Test RE-3</p> <ul style="list-style-type: none"> • Simultaneously tests the vertical and horizontal wind gust load coefficient • Failure is the loss of securement of any component of the roof edge system. 	 <p>The diagram shows two cross-sections of a roof edge. The left diagram shows a coping on top of the roof edge with a vertical 'Top Load' and a horizontal 'Face Load' applied to the coping. The right diagram shows a coping on top of the roof edge with a vertical 'Top Load' and a horizontal 'Back Leg Load' applied to the coping. The force is labeled '(Force = F)'.</p>

ES-1 / FM Compliance

Versico supplies a wide range of metal fascia systems which meet the referenced design guidelines and carry FM Class 1-90 approval. Versico's metal edging is also covered by the Versico Membrane System Warranty.

Versico Metal Edging				
Product – OLD	NEW	Type	FM Approval	ES-1 Compliant
VersiTrim 300 Coping	VersiTrim CF Coping	Coping	Yes	Yes
VersiTrim 3000 Fascia	VersiTrim CF Snap-On Fascia	Fascia	Yes	Yes
VersiTrim 200 Coping	VersiTrim Coping	Coping	Yes	Yes
VersiTrim 200 Fascia	VersiTrim Snap-On Canted Fascia	Fascia	Yes	Yes
VersiTrim System 200 Fascia	VersiTrim Crimp-On Canted Fascia	Fascia	Yes	Yes
VersiTrim 2000 Fascia	VersiTrim EX Snap-On Fascia	Fascia	Yes	Yes
VersiTrim 2000 Canted Fascia	VersiTrim EX Canted Fascia	Canted Fascia	Yes	Yes
Versico One Fascia	VersiTrim One Fascia	Fascia	Yes	Yes
VersiTrim 200 Gravel Stop	VersiTrim Gravel Stop	Edging	Yes	Yes
VersiTrim 200 Gold Coping	VersiTrim Gold Coping	Coping	Yes	Yes
VersiTrim One Coping	VersiTrim One Coping	Coping	Yes	Yes
VersiTrim 200 Continuous Cleat Coping	VersiTrim Continuous Cleat Coping	Coping	Yes	Yes
VersiTrim 2000 Drip Edge	VersiTrim EX Drip Edge	Edging	Yes	Yes
VersiTrim 200 TPO Coated Drip Edge	VersiTrim TPO Coated Drip Edge	Edging	Yes	Yes
VersiTrim 200 PVC Coated Drip Edge	VersiTrim PVC Coated Drip Edge	Edging	Yes	Yes
VersiTrim 200 TPO Skirted Drip Edge	VersiTrim TPO Skirted Drip Edge	Edging	Yes	Yes
VersiTrim 200 PVC Skirted Drip Edge	VersiTrim PVC Skirted Drip Edge	Edging	Yes	Yes

Shop Fabricated Metal

One of the leading causes of wind related disturbances is improperly designed, manufactured or installed metal fascia systems. All too frequently, shop fabricated metal accessories do not meet industry recognized standards.

Countless studies, many initiated by hurricanes, have pointed to metal edge components as a major contributor to roof failures. These components are vulnerable since the building edge is first hit, with winds and uplift pressures are always greatest at perimeters and especially roof corners.

When metal edging or coping is to be installed (particularly when shop fabricated), it is strongly advised that the design conforms with the Factory Mutual recommendations identified in Loss Prevention Data Bulletin 1-49 and with SMACNA (Sheet Metal and Air Conditioning National Association) specifications. To ensure such compliance, specify FM 1-90 approved metal edge systems and request certification from the manufacturer.

Guide for Sheet Metal Fascia Edges

(Reprinted from the NRCA Roofing Manual: Architectural Metal Flashing, Condensation and Air Leakage Control, and Reroofing - 2014)

Recommended Minimum Gauges for Fascia and Cleat ¹				
Exposed Face Without Brakes "A" Dimension	Aluminum Alloy (3003-H14)	Galvanized or Coated (G60 & G90) Steel	Stainless Steel (302 & 304)	Cleat ²
Up to 3" Face	.032"	24 ga.	26 ga.	Same gauge as fascia metal
3" to 6" Face	.040"	24 ga.	24 ga.	One gauge heavier than fascia metal
6" to 8" Face	.040"	24 ga.	24 ga.	One gauge heavier than fascia metal
8" to 10" Face	.050"	22 ga.	22 ga.	One gauge heavier than fascia metal
More than 10" Face	Add brakes to stiffen or use two-piece face	Add brakes to stiffen or use two-piece face	Add brakes to stiffen or use two-piece face	One gauge heavier than fascia metal

Recommended Profiles and Fastening for Fascia and Cleat¹

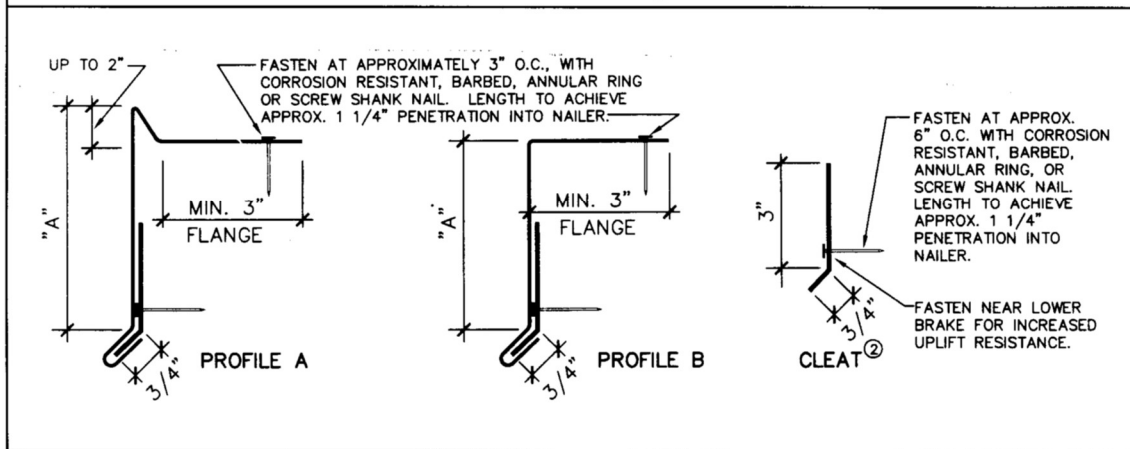

Notes:

1. Consideration must be given to wind zone and local conditions in regard to the selection of metal gauge, profile, and fastening schedule. Severe conditions or code and regulatory bodies may require more conservative designs. When using the above table, additional items should be considered, such as fastening pattern.
2. All cleats shall be continuous with lengths not to exceed 12 feet. Allow a 1/4" gap between pieces. Joints in cleat should not coincide with joints in fascia metal.
3. The securement of perimeter wood nailers, play an equally important role in the overall performance of metal fascias systems. Design Criteria for the attachment of wood nailers and associated metal edge components are also identified in the FM 1-49 Bulletin.

Why Specify Pre-Manufactured Roof Edges? Top 10 Reasons

Listed below are the top 10 reasons to specify Pre-Manufactured Metal Edge Systems versus Shop Fabricated Metal:

Pre-Manufactured

Known high quality that is consistent each time and available nationwide

Snap-on details with no exposed fasteners for a clean look without leaks

Pre-punched slotted fastener holes to assure proper fastener location and to allow for thermal movement

Concealed internal splice plates for smooth, maintenance free joints

Factory fabricated and finished miters, end caps, and accessories provide clean, professional appearance

Radius sections are welded to fit the project's actual conditions providing a smooth, finished look

ANSI/SPRI ES-1 tested for wind resistance per International Construction Code as is now required in many States

Independently tested and granted a FM approval rating by the Factory Mutual Insurance Company

Included as part of the Roofing System Warranty with coverage up to 30 years and peak gust wind speed coverage up to 120 mph

Factory finishes that incorporate Kynar 500 or Hylar 5000 baked-on architectural paint to provide a finish that is warranted for up to 20 years

Shop Fabricated

Unknown, possibly poor quality, that will vary by contractor and location

Exposed fasteners that can rust, leak, and prohibit required thermal movement

Fasteners driven through the roof edge in the field may be spaced improperly and do not allow for thermal movement as required

Frequently use exterior "band aid" splices that are unsightly and require maintenance

Miters, end caps, and accessories are field fabricated; often yielding a cobbled together appearance

Segmented straight lengths, or riveted or seamed radius, give a rough, unprofessional appearance

No testing and may not meet local building codes

No testing or FM approval

Little or no warranty protection provided by companies with varying, unknown levels of experience

Field painted edge metal is often not properly prepared to assure good paint adhesion; also, many paints will not hold up to extreme UV exposure which can result in fading and chalking over time

Copyright 2026 Versico

Versico and VersiTrim are Trademarks of Versico

Kynar is a Trademark of Arkema Inc.

This specification represents the applicable information available at the time of its publication. Owners, specifiers and Versico authorized roofing contractors should consult Versico or their Versico Independent Sales Representative for any information, which has subsequently been made available.

Review the appropriate Versico warranty for specific warranty coverage, terms, conditions and limitations.

