



SPECIFICATION

SUPPLEMENT

G-16

Plaza Paver Systems Adhered, Mechanically Fastened or Induction Welding Attachment Method

January 2026

The information contained in this supplement serves as criteria for Specifiers and Authorized Contractors regarding the design and installation of Versico Roofing Systems and related products. Additional information essential for the design and installation of the Roof Systems mentioned herein are also included in the respective Specification for each Roof System and in the Design Reference Section of the Versico Technical Manual. Specifiers and Authorized Contractors are advised to reference all applicable sections.

A. Description

The roofing assembly incorporates Versico supplied Concrete, Porcelain, Rubber or Wood Pavers in conjunction with a Versico Roofing membrane (EPDM, TPO, PVC, KEE HP) system installed in accordance with the appropriate Versico Roof Membrane Specification.

1. Membrane Roof Systems

The concrete, porcelain or wood pavers are installed over a slip sheet of HP Protective Mat or 300 HV Protection Fabric in conjunction with an approved Paver Pedestal System over the roof membrane (EPDM, TPO, PVC or KEE HP). The Rubber Pavers are installed directly over the roof membrane (EPDM) or over a slip sheet of 300HV Protection Fabric (TPO, PVC or KEE HP).

- a. **Adhered Assemblies** – Using EPDM, TPO, PVC or KEE HP, insulation may be installed either mechanically (fastened directly to the deck) or set in Flexible DASH bead adhesive to the structural deck. Subsequent layers of insulation or coverboard may be mechanically fastened through all layers or set in Flexible DASH bead adhesive. The membrane shall be fully adhered using the appropriate bonding adhesive following Versico's Thermoset (EPDM), Thermoplastic (TPO, PVC, and KEE HP), VersiFleece (EPDM, TPO, PVC or KEE HP) or VersiFleece AFX (EPDM or TPO) membrane Specifications.
- b. **Induction Welded Assemblies** – Using TPO or PVC, insulation is mechanically fastened using appropriate Versico Fasteners and TPO or PVC Induction Welding Plates which are used to secure both layers to the structural deck. The fastening density of the plates and fasteners shall be in compliance with the Induction Welding Attachment (Attachment I) of the Thermoplastic Specification.
- c. **Mechanically Fastened Assemblies** – Using EPDM, TPO, PVC or KEE HP, membranes are mechanically fastened over insulation/underlayment to the deck with the appropriate Versico Fasteners and Fastening Plates. The fastening density of the plates and fasteners shall be installed per Versico's Thermoset (EPDM), Thermoplastic (TPO, PVC, and KEE HP) membrane Specification.

2. Inverted Roof Membrane Assembly (IRMA) Systems

A layer of drainage board/mat is loose-laid over the membrane. Layers of insulation are also loose-laid directly on the drainage board/mat. The concrete, porcelain and wood pavers are installed over a slip sheet of HP Protective Mat or 300HV Protection Fabric in conjunction with an approved Paver Pedestal System over the insulation. The rubber pavers are installed over a slip sheet of HP Protective Mat over the insulation. NOTE: Porcelain and Rubber Pavers are lightweight, weighing 9 lb/sf and 6 lb/sf respectively. Check current building code requirements for building height, parapet height and project location to ensure that these overburden options are suitable in IRMA Assemblies.

- a. **Adhered Assemblies** – Using EPDM, TPO, PVC or KEE HP, the membrane is applied to the structural deck with an appropriate bonding adhesive.
- b. **Induction Welded Assemblies** – Using TPO or PVC, insulation is mechanically fastened using appropriate Versico Fasteners and TPO or PVC Induction Welding Plates are used to secure both layers to the structural deck. The

fastening density of the plates and fasteners shall be in compliance with the Induction Welding Attachment (Attachment I) of the Thermoplastic Specification.

- c. **Mechanically Fastened Assemblies** – Using EPDM, TPO, PVC or KEE HP, the membrane is installed mechanically fastened directly to the structural deck.

Any of the assemblies described herein, using a minimum 60-mil membrane, are eligible for a 5, 10, 15, or 20 Year Membrane System Warranty with a Warranty wind speed up to 72 mph. For higher wind speed coverage, project may be submitted to Versico for Approval. An Overburden Removal and Replacement Warranty is available with all Versico supplied Plaza Paver Systems (Concrete, Porcelain and Rubber) with 10, 15, or 20 Year Durations for an additional fee.

B. Quality Assurance

1. The specified roofing system must be installed by a Versico Authorized Roofing Contractor in compliance with drawings and specifications as approved by Versico.
2. Roof system must be inspected and approved by a Technical Representative of Versico prior to Plaza Paver System installation.
3. Do not install this assembly before the concrete deck has reached its' initial structural strength. Project Engineer must be consulted prior to job start-up.

C. Submittals

1. Shop drawings must be submitted to Versico by the Versico Authorized Roofing Contractor along with a completely executed Copy-A Job Approval Request for approval. Approved shop drawings are required for inspection of the roof and on projects where on-site technical assistance is requested.
2. Upon completion of the installed work, submit copies of the manufacturer's final inspection to the specifier prior to the issuance of the manufacturer's warranty.

D. Products

In addition to the products listed below, products listed in "Part II" of the Versico Thermoset/Thermoplastic Roofing System Specification can be used as part of the Plaza Paver System.

1. Hanover® Pavers

- a. **Prest Pavers:** Hanover Roof and Plaza Pavers provide durability, protection and performance for the roof system from harsh weather conditions. A textured Tudor® finish provides slip resistant properties making Hanover Pavers safer than gravel ballast for pedestrians. By elevating the pavers, water is channeled away from the surface. Roof Pavers allow easy access to the roof and waterproofing system for repairs or standard maintenance procedures. Available in Tudor Finish, 8 standard colors (custom available), in a standard size of 23.5" x 23.5" x 2" (other sizes available upon request) and weighs 25 lb/sf. The use of Hanover Pavers requires the use of one of the pedestals below to maintain material warranty.

1. **High Tab Pedestals** – are 5/8" high and are stackable to increase the height.
2. **EPDM Pedestal and Leveling Shims** – are 3/8" fixed height but are not stackable.
3. **Elevator Pedestal** – consisting of a base and top plate which can be combined with various size couplers to increase height.

- b. **Pedestal Pavers:** For use as an alternative to standard concrete pavers and polyethylene or EPDM pedestal systems, Hanover Pedestal Pavers are produced with integrated concrete feet providing a 1/2" elevation clearance for water drainage. Available in Tudor Finish (for aesthetics) or Diamond (for walkways), 8 standard colors (custom available), in a standard size of 23.5" x 23.5" x 2.25" and weighs 22 lb/sf. As the paver is produced with integral, pedestal feet, additional pedestal systems are not recommended or required. The use of 300HV Protection Fabric is required with this paver.

- c. **Guardian Pavers:** The Hanover Guardian® Paver System is specially designed to create a monolithic paver surface which provides high wind uplift resistance. Guardian is made up of a unique 3-piece Guardian Pedestal and a specially shaped Guardian Paver that, together, "lock down" and unitize the entire roof paver surface, preventing horizontal and vertical movement. The Guardian Pedestal has a square top that allows its bolt to pass through to a base beneath, fitting into a recessed grooved portion of the Guardian Paver. Available in multiple finishes, 10 standard colors (custom available), in standard sizes of 17.625" x 35.375" x 2" or 3", 23.5" x 23.5" x 2" or 3", 23.5" x

35.375" x 2" or 3", OR 29.75" x 29.75" x 2" and weighs 25 lb/sf for 2" thicknesses and 38 lb/sf for 3" thicknesses. Guardian pavers must be used with specialized pedestals consisting of a standard elevator pedestal base combined with a patented locking top cap (available in 8 colors). The system achieved -81.1 psf uplift resistance according to Florida's TAS (Testing Application Standard) 108 test.

- d. **Porcelain Pavers:** Hanover® Porcelain Pavers are a premium alternative to concrete pavers. They are hard-wearing, anti-slip, weather resistant and capable of withstanding heavy loads without comprising aesthetics. Porcelain Pavers are resistant to acid, chemicals, mold and salt. They will not stain and do not require sealing. Porcelain Pavers are installed over standard Hanover elevator pedestal bases combined with Hanover's low-tab pedestal tops specially designed for the porcelain pavers, providing an 1/8" joint for water drainage. Porcelain Pavers only weigh approximately 9 pounds per square foot and do not satisfy typical ballast uplift requirements. To increase wind uplift performance, combine with Hanover's ballasted GridLoc structural support system. Available in multiple finishes, 17 colors/designs, in standard sizes of 12" x 48" x 2" or 3/4", 16" x 32" x 3/4", 16" x 48" x 3/4", 24" x 24" x 3/4" OR 24" x 48" x 3/4" and weighs approximately 9 lb/sf.
- e. **GridLoc System:** Hanover's GridLoc® System creates a lightweight, elevated structural support for various overburden systems including concrete pavers, porcelain pavers, bricks, and roof garden trays. When paired with Hanover's adjustable pedestals with special GridLoc pedestal tops, the GridLoc System creates a level, elevated, and fully supported continuous base for systems previously unsuitable for pedestal support. GridLoc must be used for porcelain paver installations above 6" in height above the membrane. For lightweight overburden products, such as porcelain pavers, installed over GridLoc, GridLoc Weights can be added to the grids and the overburden adhered to the grids to enhance wind resistance.
- f. **GridLoc Grid:** Hanover GridLoc Grids are specially designed, lightweight, structural support panels that create a continuous, fully supported, base for elevated overburden installations. GridLoc Grids are installed over adjustable pedestals to allow for height and slope adjustment. The GridLoc Grids are nominally sized at 16" x 24" x 1.5", cover approximately 2.66 square feet, and weigh 6 pounds each. Grids feature three hexagonal-shaped holes to accept GridLoc Weights or Plugs.
- g. **GridLoc Weight:** GridLoc Weights are specially designed to fit snugly into the hexagonal shaped holes in the GridLoc Grids to provide additional wind resistance. Each GridLoc Weight is wrapped in thermoplastic material for long-term durability. Weighing 5.31 pounds each, the GridLoc weights can add 5.31 pounds, 10.62 pounds, or 15.93 pounds of additional weight when adding one, two, or three Weights, respectfully.
- h. **GridLoc Plug:** GridLoc Plugs are designed to fill the hexagonal-shaped holes in the Grids when GridLoc Weights are not used.
- i. **GridLoc Pedestal Top:** GridLoc Pedestal Tops are used in conjunction with standard Hanover Elevator pedestal bases to provide elevation for the GridLoc system. GridLoc Pedestal Tops feature specially designed pegs that snap into holes located on the bottom of the GridLoc Grids, for proper spacing and securement.

2. Sunny Brook Pavers

- a. **Pressed Concrete Pavers:** Sunny Brook pressed concrete pavers are available in a wide variety of sizes, colors, patterns and textures to accent any building, decor and landscaping. The standard Quarry Stone texture combines aesthetic appeal of decorative aggregates with the strength of concrete to create pavers that are strong, durable and beautiful. Available in Quarry Stone Texture (standard, with 5 additional finishes available), 21 standard colors, in a standard size of 23.5" x 23.5" x 2" (additional sizes available upon request) and weighs 24 lb/sf. Sunny Brook Pavers use MRP Support pedestals as supplied by Versico.

3. Westile Pavers

- a. **Western Plaza Pavers:** Westile Western Plaza Pavers are made of a high-density concrete and are well-suited for use in plaza decks, providing a durable, elegant surface while protecting the roof membrane and increasing amenity space. Westile Western Plaza Pavers are to be used in conjunction with high-density polypropylene pedestals that facilitate proper spacing and drainage and provide the ability to create a dead level surface. Available exclusively for projects in the western United States and Canada including the following states and provinces: Alaska, Arizona, California, Colorado, Hawaii, Idaho, Montana, Nevada, New Mexico, Oregon, Utah, Washington, Wyoming, British Columbia, Alberta, Saskatchewan. Available in Shot Blast Texture (standard, with matte finish available as a special order), 7 standard colors, in a standard size of 24" x 24" x 1.8125" (additional sizes available upon request) and weighs 23 lb/sf. Westile Western Plaza Pavers use Bison or MRP Support pedestals as supplied by Versico.

4. Versico Rubber Pavers

- a. **Plus Series Rubber Pavers:** Made of recycled rubber, the Plus Series pavers are an economical solution intended for use in low traffic areas as well as walkways to rooftop mechanical units. Available in 6 standard colors, in a

standard size of 24" x 24" x 2" and weighs 6 lb/sf. Special adhesive must be applied to all paver-to-paver joints using a special adhesive application tip, once all pavers are in place. Adhesive helps keep pavers from separating during expansion and contraction due to temperature fluctuations. Pavers are installed directly over EPDM roofing membranes or over 300HV Protection Fabric for TPO, PVC and KEE HP roofing membranes.

- b. **Premium Rubber Pavers:** Premium Series Rubber Pavers feature a top wearing surface of SBR recycled rubber as well as varying percentages of EPDM virgin rubber for superior durability, as well as, wear and fade resistance. This makes the Premium Series pavers ideal for high traffic and plaza areas, and a great alternative to concrete paver systems. The Premium Series also features a broader range of color options that can aide in artistic rooftop design. Available in 10 standard colors, in a standard size of 24" x 24" x 2" and weighs 6 lb/sf. Special adhesive must be applied to all paver-to-paver joints using a special adhesive application tip, once all pavers are in place. Adhesive helps keep pavers from separating during expansion and contraction due to temperature fluctuations. Pavers are installed directly over EPDM roofing membranes or over 300HV Protection Fabric for TPO, PVC and KEE HP roofing membranes.
5. **Bison Wood Pavers:** Commercial grade, hardwood, weather-resistant unitized pavers. Modular 2' x 2', 4' x 2'. Slope compensators are available. Custom sizes are available.
- a. **Bison Ipe Wood Tiles:** ASTM E108 Class A Flame Spread; ANSI A137.1 Slip Resistance; ASCE 7 certified. Available in 2' x 2' (23.875" x 23.875" x 1.69"), 4' x 2' (47.9375" x 23.875" x 1.69"), 6 psf and 7.5 psf. Available with Smooth or Ribbed surface.
 - b. **Bison Cumaru Wood Tiles:** ASTM E108 Class A Flame Spread; ANSI A137.1 Slip Resistance; ASCE 7 certified. Available in 2' x 2' (23.875" x 23.875" x 1.69"), 4' x 2' (47.9375" x 23.875" x 1.69"), 6 psf. Available with Smooth surface only.
6. **Versico Supplied System Accessories:**
- a. **HP Protection Mat:** a nominal 6 oz. per square yard, UV-resistant, polypropylene, needle-punched fabric. HP Protective Mat is installed as a slip sheet for some paver applications. Available in 15' x 300' rolls.
 - b. **300HV Protection Fabric:** a (16 oz/ sq yd) extremely tough non-woven polypropylene fabric designed for use as a protection course over Versico's roofing membranes providing cushion for heavy overburden materials. 300HV Protection Fabric is non-biodegradable and stabilized to resist soil, chemicals and mildew, as well as acids and alkalis. Available in 40" x 200' rolls.

E. Execution

Follow current specifications for installing roof membranes and seaming per specific membrane. (VersiGard (EPDM), VersiWeld (TPO) or VersiFlex (PVC/KEE HP)).

General

Exercise care in placing pavers and pedestals over roofing or waterproofing so protection materials are not displaced and roofing or waterproofing is not punctured or otherwise damaged. Carefully replace protection materials that become displaced and arrange for repair of damaged roofing or waterproofing before covering with paver system.

F. Installation

1. Proceed with installing roofing system as described in this section and in accordance with Versico published Specifications for the specific membrane type.
2. After installation of the roofing membrane, install slip sheet of HP Mat or 300HV Protective Fabric, as required by paver system, as outlined above.
3. Install appropriate paver pedestal as outlined by the plaza paver system selected.
4. Install Plaza Paver according to manufacturer's written instructions.

G. Associated Installation Details

Concrete Pavers on Pedestals.....	PD-A
Concrete Pavers on Low-Rise or Fixed Height Pedestals.....	PD-B
Concrete Pedestal Pavers	PD-C
IRMA Concrete Paver Assembly – Option 1	PD-D
IRMA Concrete Paver Assembly – Option 2	PD-E
Wood Pavers on Pedestals.....	PD-F
GridLoc Paver Detail.....	PD-G
Drain Detail – Low-Rise or Fixed Height Paver Assemblies.....	PD-6.1
Drain Detail –Adjustable Height Paver Pedestal Assembly.....	PD-6.2
Vertical Termination	PD-12.1
Vertical Termination – High-Wind Option	PD-12.2
Horizontal Termination – Aesthetic Option.....	PD-12.3
Horizontal Termination – High-Wind Option.....	PD-12.4
Rubber Interlocking Pavers.....	PD-RA
Rubber Paver Joint Adhesive Application	PD-R4.1
Drain Detail - Rubber Paver.....	PD-R6.1
Horizontal Termination – Aesthetic Option.....	PD-R12.3
Horizontal Termination – High-Wind Option.....	PD-R12.4

End of Section

Copyright 2026 Versico
 Versico, ChannelDry, VersiGard, VersiWeld and VersiFlex are Trademarks of Versico

Hanover, Tudor Hanover Pedestal and Guardian are Trademarks of Hanover Architectural Products

This specification represents the applicable information available at the time of its publication. Owners, specifiers and Versico Authorized Roofing contractors should consult Versico or their Versico Independent Sales Representative for any information, which has subsequently been made available.



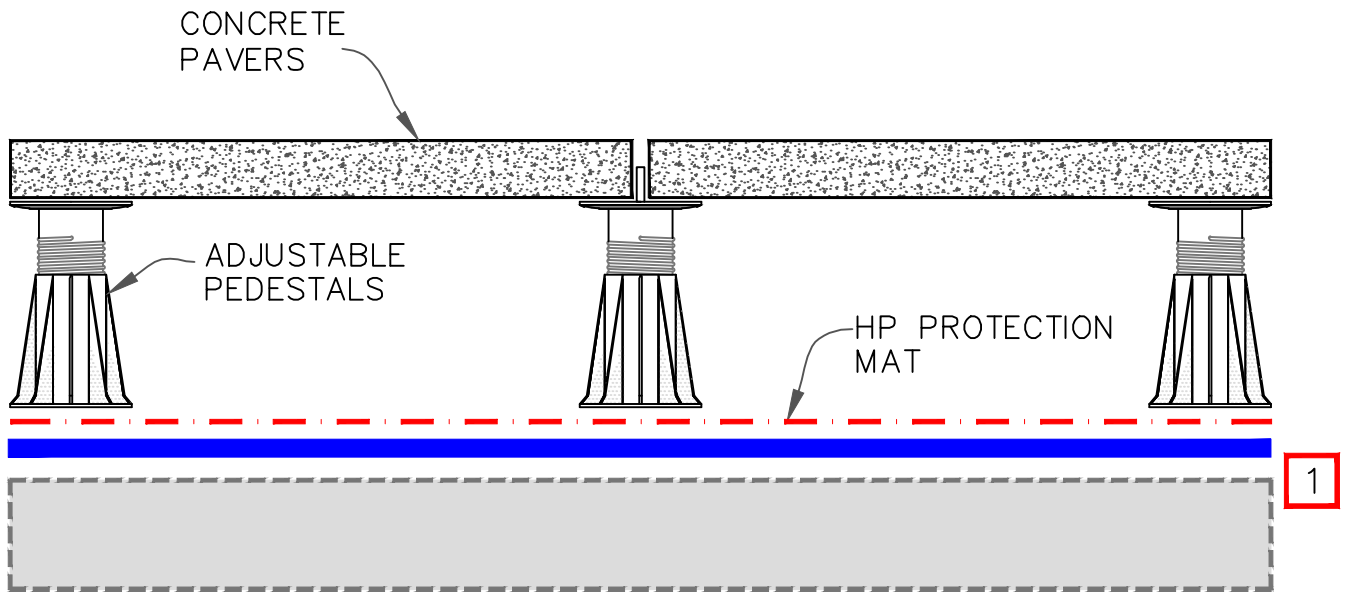

Review the appropriate Versico warranty for specific warranty coverage, terms, conditions and limitations.



NOTES:

1. APPROVED ROOF ASSEMBLY. REFER TO SPECIFICATIONS







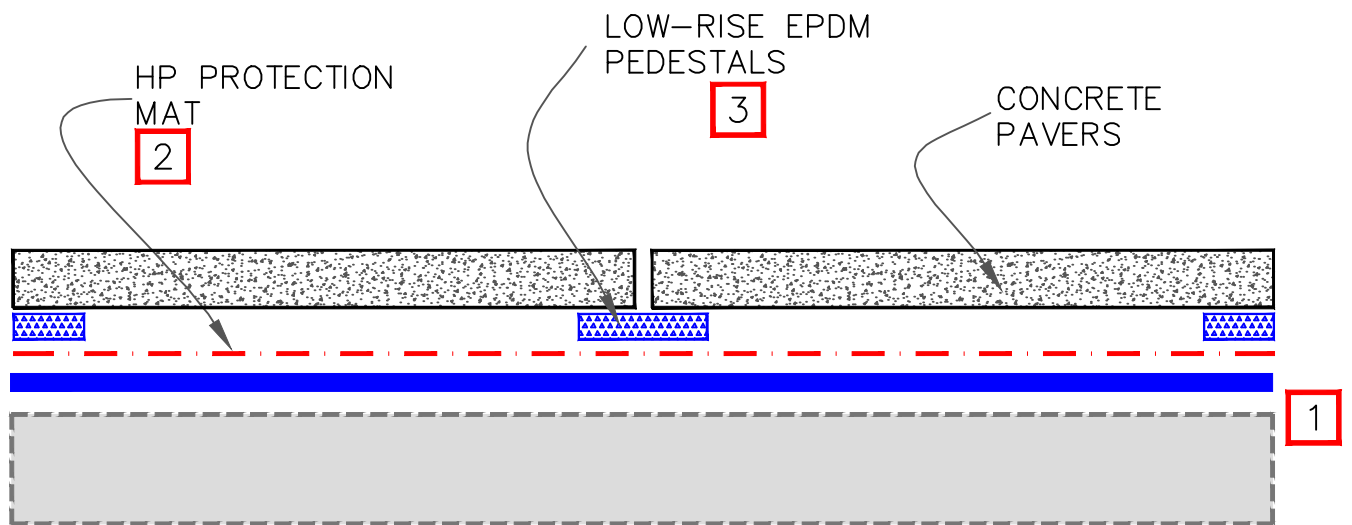

-  • EPDM/TPO/PVC
-  • CONCRETE
-  0 • SEE NOTE(S)
-  • HP PROTECTIVE MAT
-  • 300HV PROTECTION FABRIC

CONCRETE PAVERS ON PEDESTALS	
PAVER DETAILS	DETAIL NO.
	PDI A



NOTES:

1. APPROVED ROOF ASSEMBLY. REFER TO SPECIFICATIONS
2. HP MAT IS NOT REQUIRED WHEN USING EPDM PEDESTALS OVER EPDM OR TPO MEMBRANES
3. AS AN ALTERNATIVE TO LOW-RISE EPDM PEDESTALS, FIXED-HEIGHT PLASTIC PEDESTALS, LEVELING SHIMS AND SLOPE COMPENSATORS CAN ALSO BE USED

 <p>VERSICO ROOFING SYSTEMS © 2026 VERSICO</p>	<ul style="list-style-type: none">  ● EPDM/TPO/PVC  ● CONCRETE  ● SEE NOTE(S)  ● HP PROTECTIVE MAT  ● 300HV PROTECTION FABRIC 	CONCRETE PAVERS ON LOW-RISE OR FIXED HEIGHT PEDESTALS	
	PAVER DETAILS	DETAIL NO. PDI B	

CONCRETE PEDESTAL
PAVERS (WITH INTEGRATED
CONCRETE FEET)



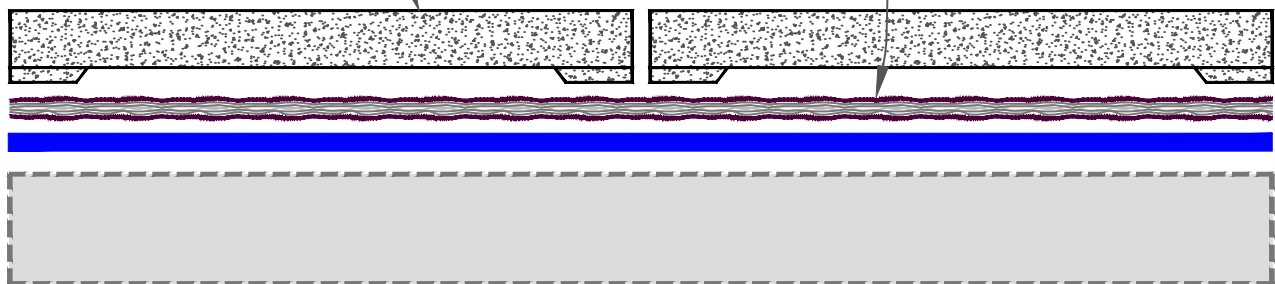

300HV PROTECTION
FABRIC



NOTE:

1. APPROVED ROOF ASSEMBLY. REFER TO SPECIFICATIONS



-  EPDM/TPO/PVC
-  CONCRETE
-  SEE NOTE(S)
-  HP PROTECTIVE MAT
-  300HV PROTECTION FABRIC

CONCRETE PEDESTAL PAVERS	
PAVER DETAILS	DETAIL NO.
	PDI C



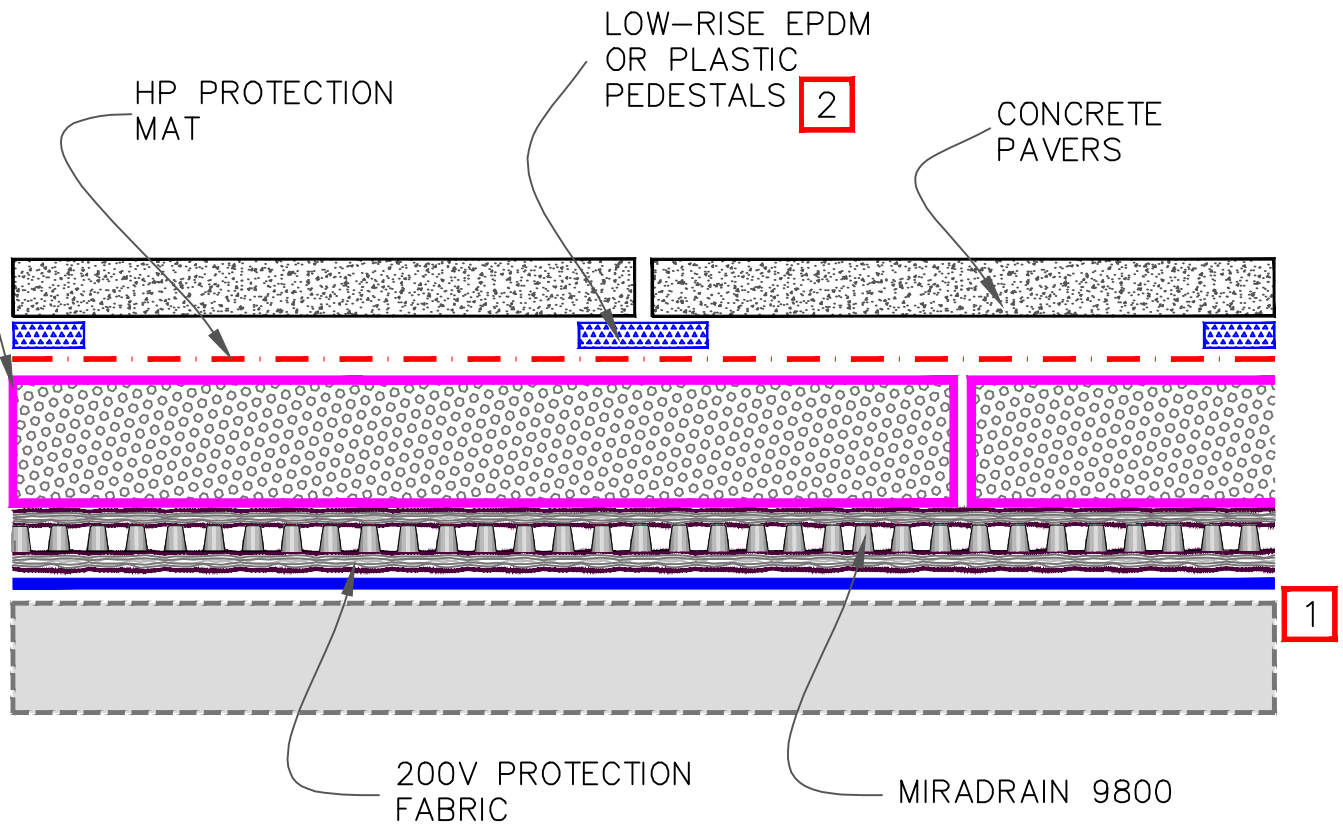

POLYSTYRENE INSULATION	
COMPRESSIVE STRENGTH	DENSITY
25 POUNDS/INCH ²	2 POUNDS/FOOT ³
17,577 KILOGRAM/METER ²	32.1 KILOGRAM/METER ³



NOTES:

1. APPROVED ROOF ASSEMBLY. REFER TO SPECIFICATIONS.
2. ADJUSTABLE SCREW-JACK PEDESTALS OR PEDESTAL PAVERS MAY ALSO BE USED.



-  • EPDM/TPO/PVC
-  • CONCRETE
-  • SEE NOTE(S)
-  • HP PROTECTIVE MAT
-  • 300HV PROTECTION FABRIC

IRMA CONCRETE PAVER ASSEMBLY – OPTION 1	
PAVER DETAILS	DETAIL NO.
	PDI D

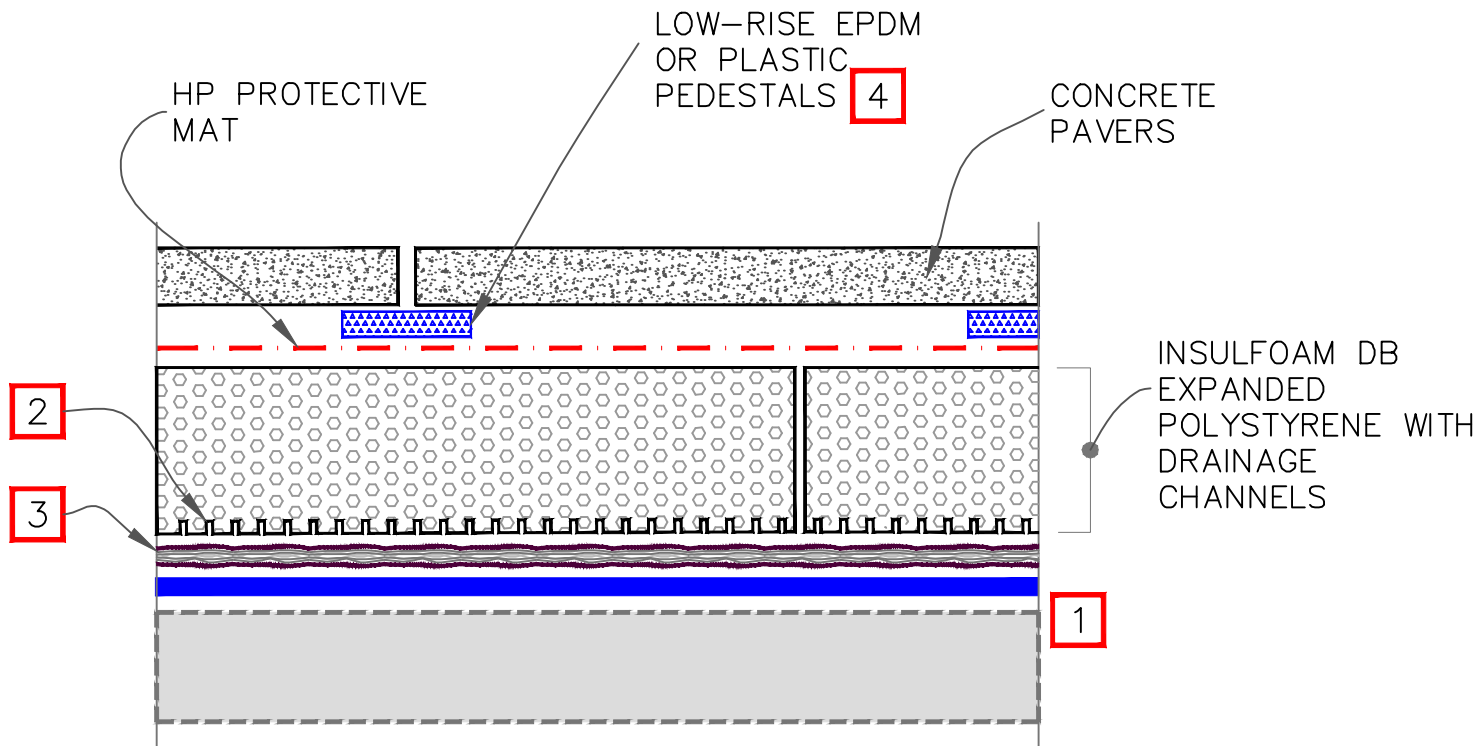

NOTES:

1. APPROVED ROOF ASSEMBLY. REFER TO SPECIFICATIONS.
2. DRAINAGE CHANNELS TO BE ORIENTED IN THE DIRECTION OF ROOF DRAINS
3. IF POLYSTYRENE INSULATION IS USED IN CONJUNCTION WITH PVC MEMBRANE, 300HV PROTECTION FABRIC IS NEEDED BETWEEN EPS AND PVC.
4. ADJUSTABLE SCREW-JACK PEDESTALS OR PEDESTAL PAVERS MAY ALSO BE USED.



- EPDM/TPO/PVC
- CONCRETE
- SEE NOTE(S)
- HP PROTECTIVE MAT
- 300HV PROTECTION FABRIC



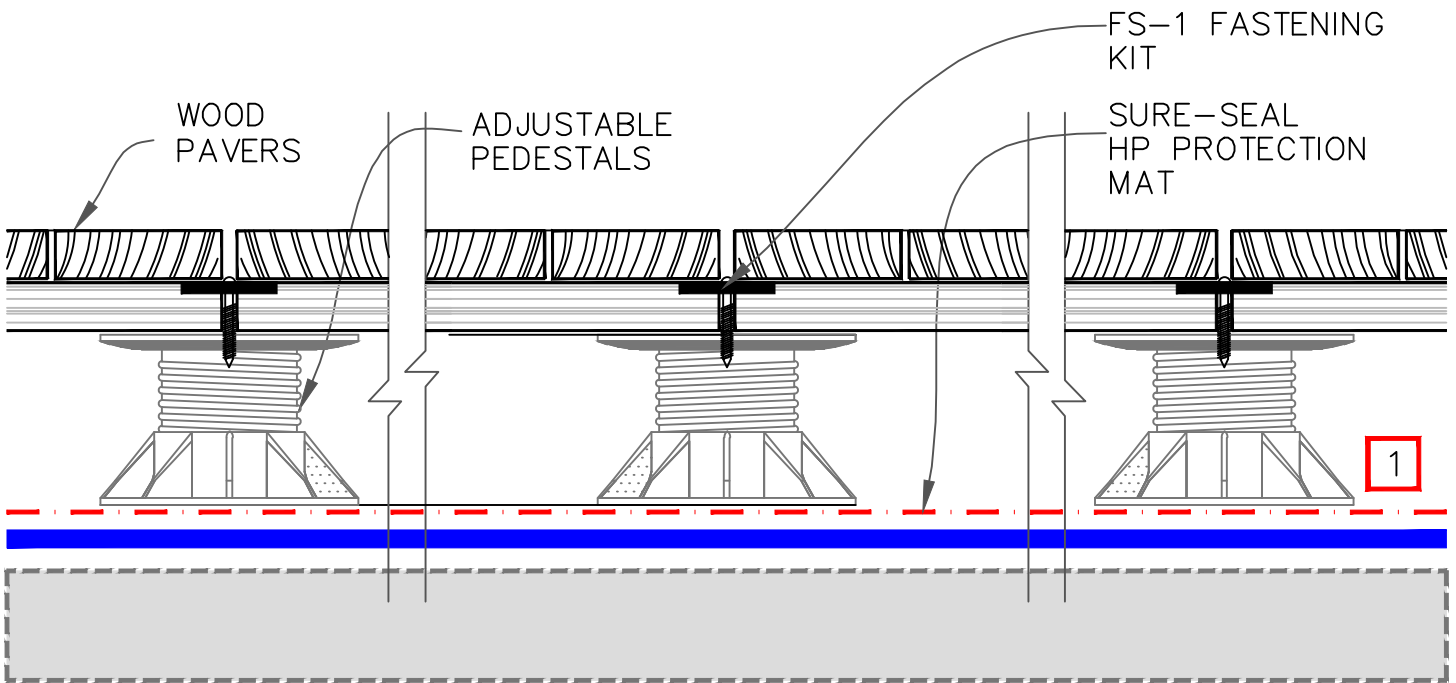

IRMA CONCRETE PAVES ASSEMBLY – OPTION 2	
PAVER DETAILS	DETAIL NO.
	PDI E



NOTES:

1. APPROVED ROOF ASSEMBLY. REFER TO SPECIFICATIONS
2. WOOD PAVERS SECURED TO PEDESTALS USING FS-1 FASTENING KIT.



-  EPDM/TPO/PVC
-  CONCRETE
- 0 SEE NOTE(S)
-  HP PROTECTIVE MAT
-  300HV PROTECTION FABRIC



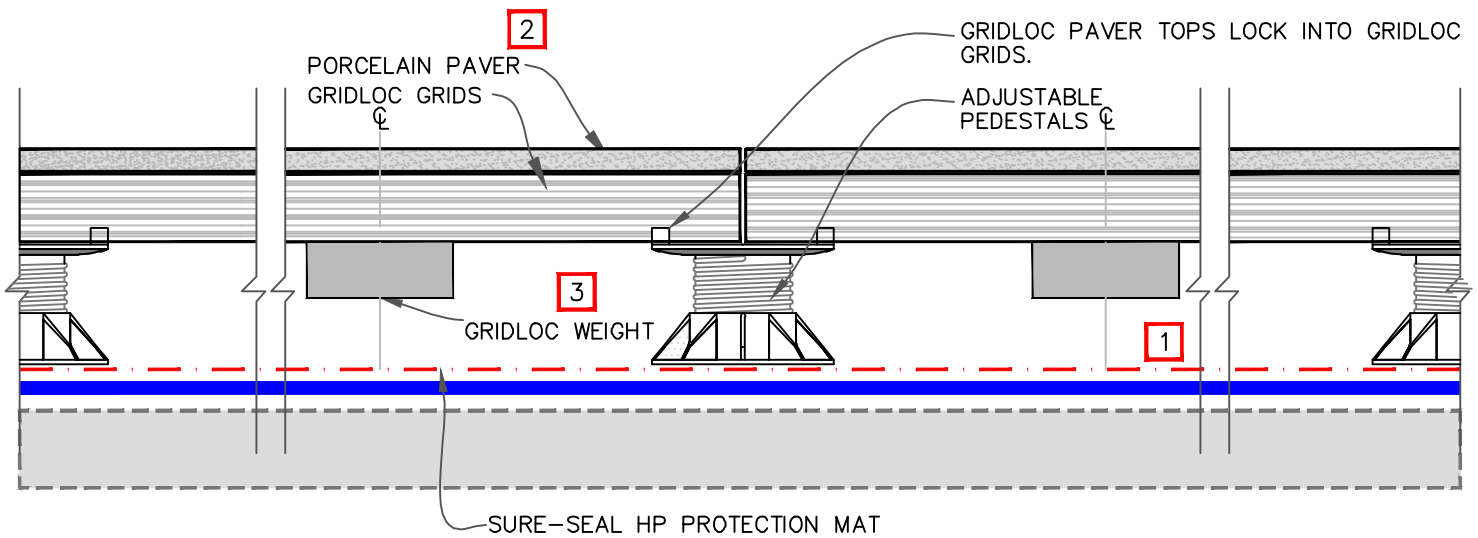

WOOD PAVER ON ADJUSTABLE PEDESTAL	
PAVER DETAILS	DETAIL NO. PDI F



NOTES:

1. APPROVED ROOF ASSEMBLY. REFER TO SPECIFICATIONS.
2. ADDITIONAL OVERBURDEN OPTIONS ACCEPTABLE. CONTACT CARLISLE FOR OPTIONS.
3. GRIDLOC WEIGHTS FOR ADDITIONAL WIND UPLIFT RESISTANCE WHEN REQUIRED. PLUGS AVAILABLE WHEN WEIGHTS ARE NOT REQUIRED.



-  EPDM/TPO/PVC
-  CONCRETE
- 0 SEE NOTE(S)
-  HP PROTECTIVE MAT
-  300HV PROTECTION FABRIC

GRIDLOC PAVER ON ADJUSTABLE PEDESTAL	
PAVER DETAILS	DETAIL NO.
	PDI G

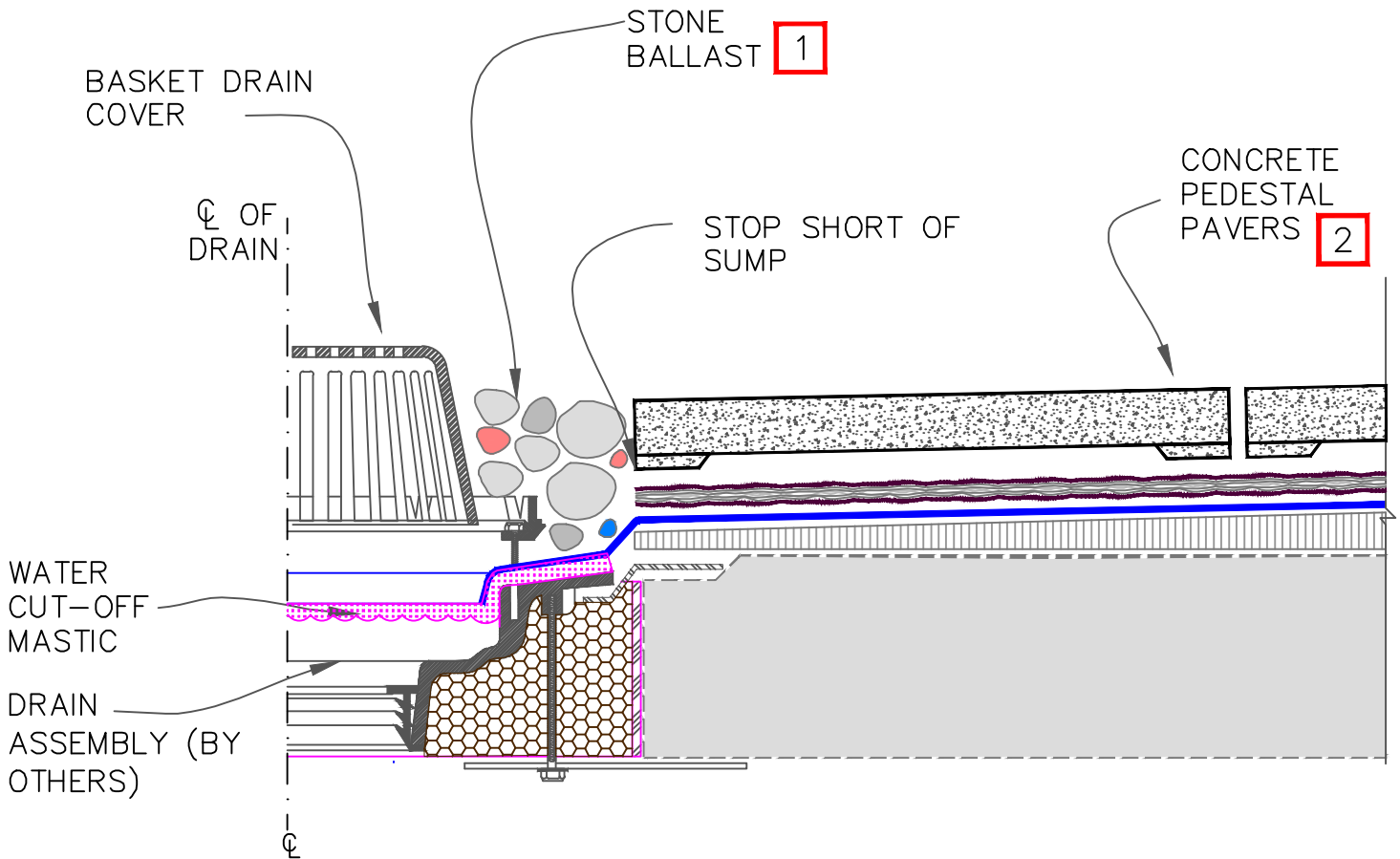

NOTES:

1. STONE BALLAST IS OPTIONAL TO PROVIDE AESTHETICS.
2. AS AN ALTERNATE TO CONCRETE PEDESTAL PAVERS, STANDARD CONCRETE PAVERS ON FIXED HEIGHT PEDESTALS CAN ALSO BE USED. REFER TO DETAIL PD B FOR ASSEMBLY INFORMATION.



- EPDM/TPO/PVC
- CONCRETE
- SEE NOTE(S)
- HP PROTECTIVE MAT
- 300HV PROTECTION FABRIC



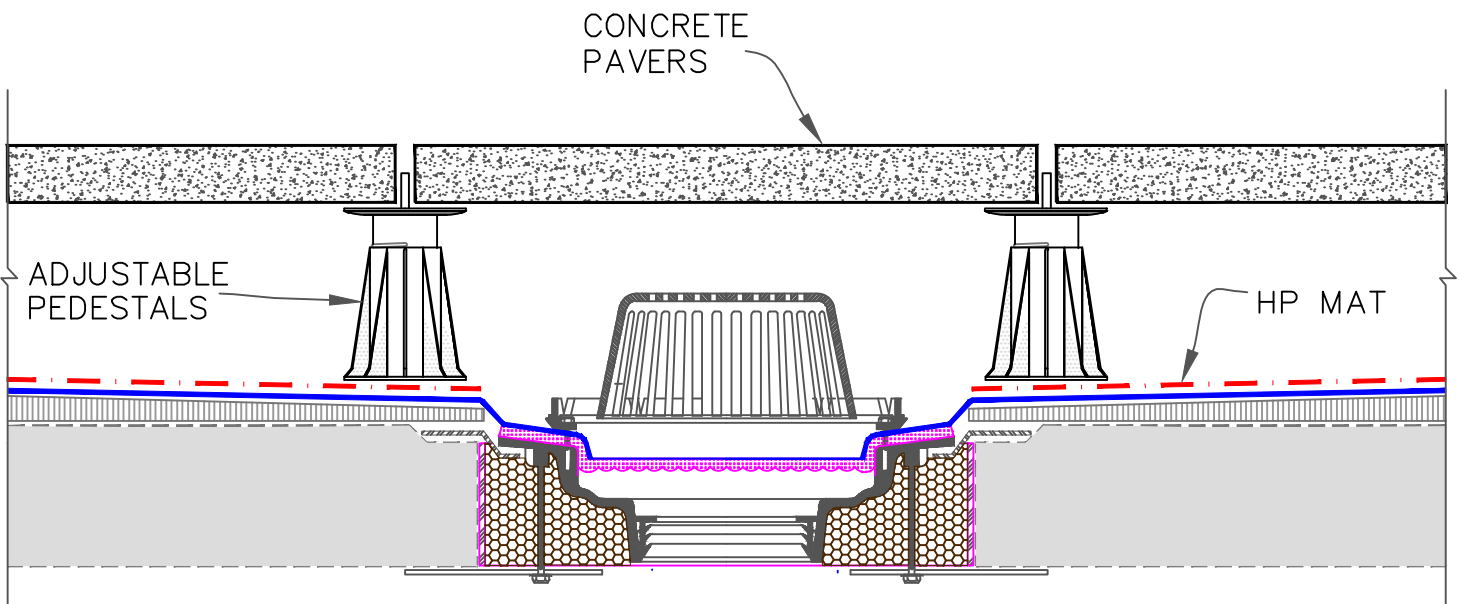

DRAIN DETAIL – LOW-RISE, FIXED HEIGHT PEDESTAL OR PEDESTAL PAVER ASSEMBLIES	
PAVER DETAILS	DETAIL NO.
	PD 6.1



NOTE:

1. THIS OPTION IS ONLY APPLICABLE TO PAVERS ON ADJUSTABLE PEDESTALS WHEN THERE IS ENOUGH HEIGHT ADJUSTMENT TO CLEAR DRAIN BASKETS



-  ● EPDM/TPO/PVC
-  ● CONCRETE
-  ● SEE NOTE(S)
-  ● HP PROTECTIVE MAT
-  ● 300HV PROTECTION FABRIC

DRAIN DETAIL – ADJUSTABLE HEIGHT PAVER PEDESTAL ASSEMBLY	
PAVER DETAILS	DETAIL NO. PDI 6.2

CAUTION

CONCRETE PAVERS MUST NOT BE USED AS WALKWAYS NEAR THE ROOF EDGES, PARAPET WALLS AND UNPROTECTED AREAS WITHOUT FALL PROTECTION.

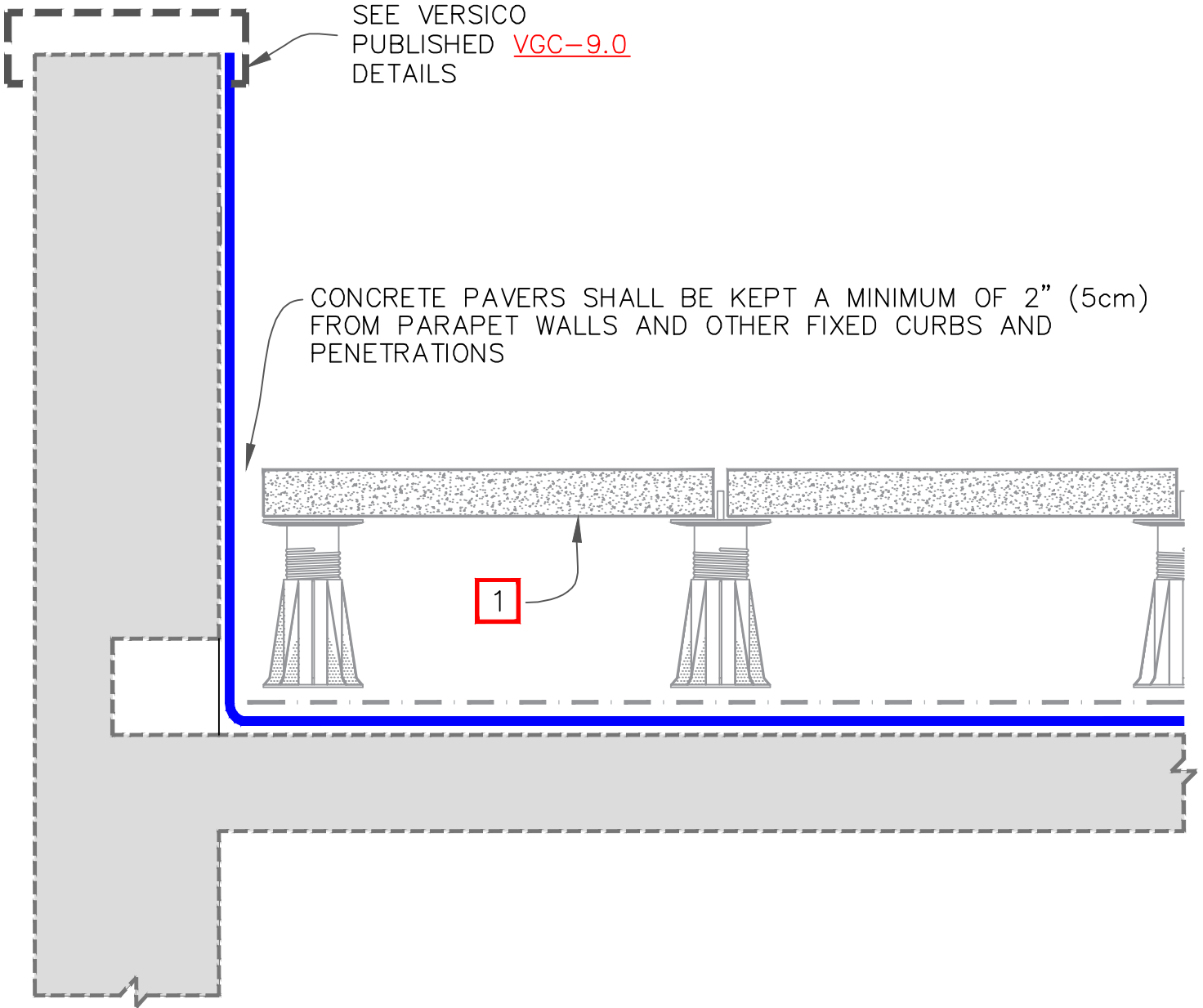

NOTE:

1. CONCRETE PAVERS ON ADJUSTABLE PEDESTALS SHOWN. REFER TO PD DETAIL B, C, D, AND E FOR ACCEPTABLE ALTERNATIVE ASSEMBLIES.



- EPDM/TPO/PVC
- CONCRETE
- 0 • SEE NOTE(S)
- HP PROTECTIVE MAT
- 300HV PROTECTION FABRIC

ALL ASSEMBLIES	
VERTICAL TERMINATION	
PAVER DETAILS	DETAIL NO. PD 12.1

CAUTION

CONCRETE PAVERS MUST NOT BE USED AS WALKWAYS NEAR THE ROOF EDGES, PARAPET WALLS AND UNPROTECTED AREAS WITHOUT FALL PROTECTION.

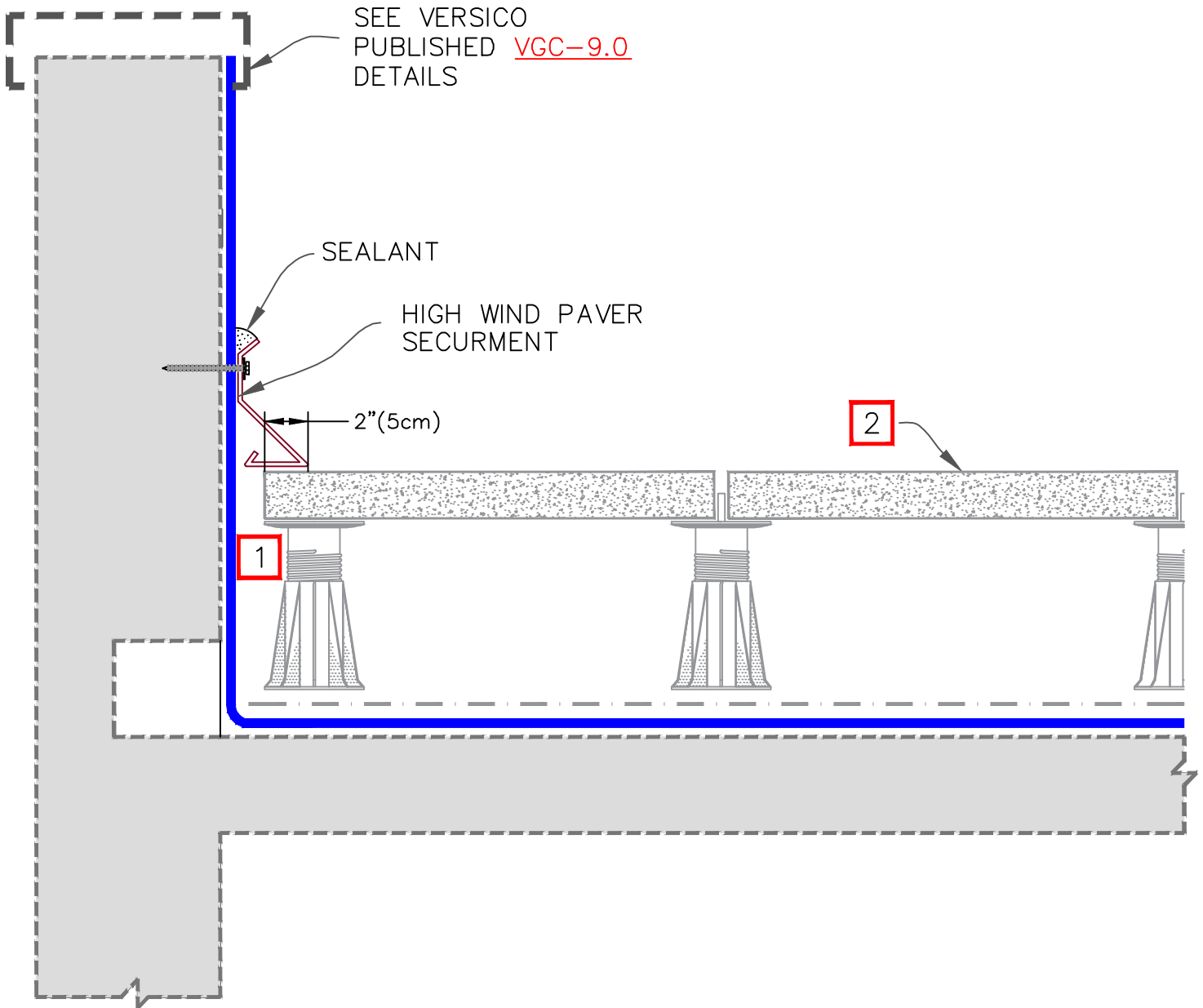

NOTES:

1. PAVERS SHALL BE KEPT A MINIMUM OF 2" (5cm) FROM PARAPET WALL.
2. CONCRETE PAVERS ON ADJUSTABLE PEDESTALS SHOWN. REFER TO PD DETAIL B, C, D, AND E FOR ACCEPTABLE ALTERNATIVE ASSEMBLIES.



- EPDM/TPO/PVC
- CONCRETE
- SEE NOTE(S)
- HP PROTECTIVE MAT
- 300HV PROTECTION FABRIC

ALL ASSEMBLIES	
VERTICAL TERMINATION HIGH-WIND OPTION	
PAVER DETAILS	DETAIL NO. PD 12.2

***CAUTION**
 CONCRETE PAVERS AS A WALKWAY MUST BE LOCATED MIN. 6'-0" (183cm) AWAY FROM THE NEAREST UNPROTECTED ROOF EDGES OR AS REQUIRED PER APPLICABLE LOCAL CODES/OSHA REQUIREMENTS.

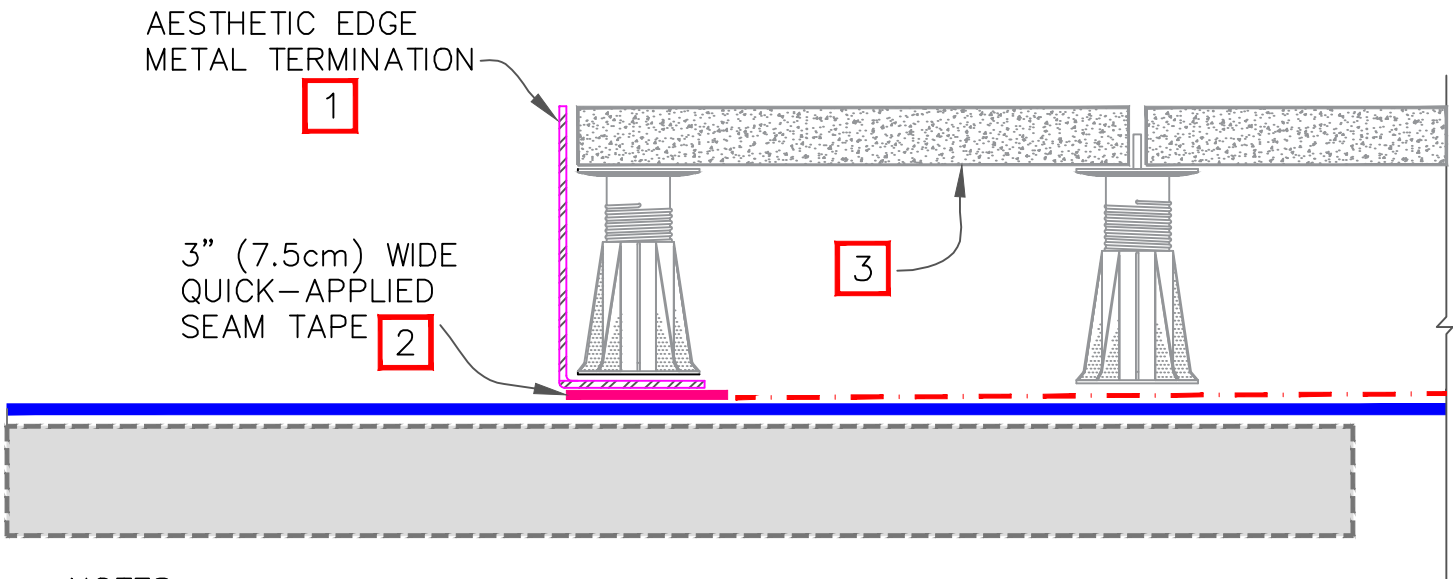

NOTES:

1. METAL EDGE TREATMENT IS USED FOR AESTHETICS AND NOT NEEDED FOR WARRANTY COMPLIANCE
2. QUICK-APPLIED SEAM TAPE SHALL EXTEND 1/4" (1cm) BEYOND EDGE OF METAL EDGE TO PROTECT ROOF MEMBRANE FROM METAL BURRS & CORNERS
3. CONCRETE PAVERS ON ADJUSTABLE PEDESTALS SHOWN. REFER TO PD DETAIL B, C, D, AND E FOR ACCEPTABLE ALTERNATIVE ASSEMBLIES.



- EPDM/TPO/PVC
- CONCRETE
- SEE NOTE(S)
- HP PROTECTIVE MAT
- 300HV PROTECTION FABRIC

ALL ASSEMBLIES	
HORIZONTAL TERMINATION AESTHETIC OPTION	
PAVER DETAILS	DETAIL NO. PDI 12.3

***CAUTION**

CONCRETE PAVERS AS A WALKWAY MUST BE LOCATED MIN. 6'-0" (183cm) AWAY FROM THE NEAREST UNPROTECTED ROOF EDGES OR AS REQUIRED PER APPLICABLE LOCAL CODES/OSHA REQUIREMENTS.

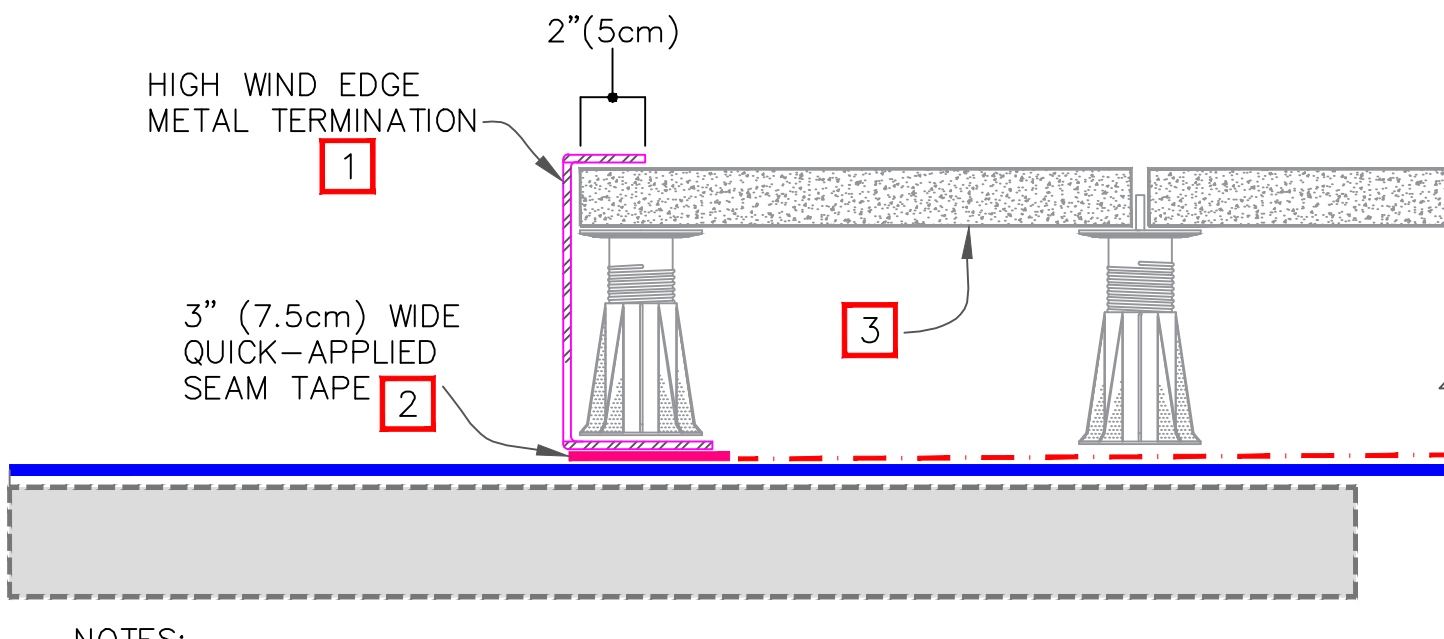

NOTES:

1. HIGH WIND METAL EDGE TREATMENT SHOULD BE USED IN HIGHER WIND APPLICATIONS TO HELP SECURE THE EXPOSED PERIMETER PAVERS. NOT REQUIRED FOR WARRANTY COMPLIANCE.
2. QUICK-APPLIED SEAM TAPE SHALL EXTEND 1/4" (1cm) BEYOND EDGE OF METAL EDGE TO PROTECT ROOF MEMBRANE FROM METAL BURRS & CORNERS
3. CONCRETE PAVERS ON ADJUSTABLE PEDESTALS SHOWN. REFER TO PD DETAIL B, C, D, AND E FOR ACCEPTABLE ALTERNATIVE ASSEMBLIES.



- EPDM/TPO/PVC
- CONCRETE
- 0** SEE NOTE(S)
- HP PROTECTIVE MAT
- 300HV PROTECTION FABRIC



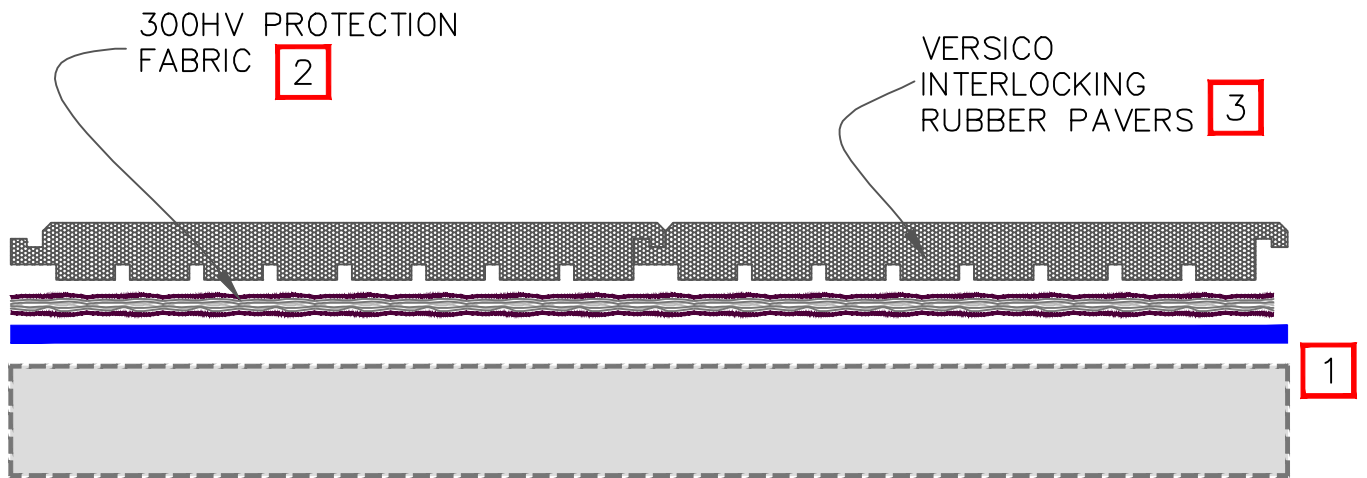

ALL ASSEMBLIES	
HORIZONTAL TERMINATION HIGH-WIND OPTION	
PAVER DETAILS	DETAIL NO. PDI 12.4



NOTES:

1. APPROVED ROOF ASSEMBLY. REFER TO SPECIFICATIONS
2. 300HV PROTECTION FABRIC IS NOT REQUIRED WHEN PLACING RUBBER PAVERS OVER EPDM MEMBRANE
3. RUBBER PAVERS MUST BE INSTALLED UNDER COMPRESSION. REFER TO VERSICO'S RUBBER PAVER INSTALLATION GUIDE FOR MORE INFORMATION.



-  → EPDM/TPO/PVC
-  → SEE NOTE(S)
-  → HP PROTECTIVE MAT
-  → 300HV PROTECTION FABRIC

RUBBER INTERLOCKING PAVERS	
PAVER DETAILS	DETAIL NO.
	PDI RA

AFTER ALL PAVERS ARE INSTALLED, CARLISLE RUBBER PAVER ADHESIVE SHALL BE APPLIED IN ALL PAVER TO PAVER JOINTS USING VERSICO'S SPECIALIZED RUBBER PAVER ADHESIVE APPLICATION TIP

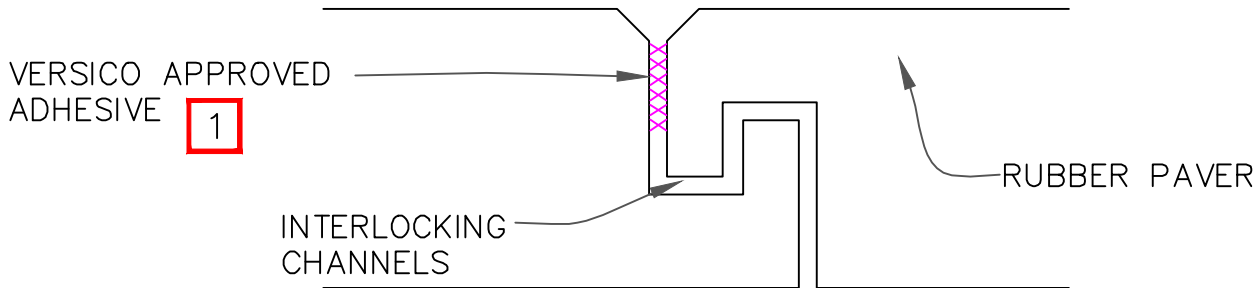

NOTES:

- ADHESIVE SHALL BE APPLIED BETWEEN THE VERTICAL WALLS OF THE INTERLOCKING JOINT AND NOT ON THE BOTTOM OF THE CHANNEL
- SEE VERSICO'S RUBBER PAVER INSTALLATION GUIDE FOR MORE INFORMATION

ADHESIVE APPLICATION TIP

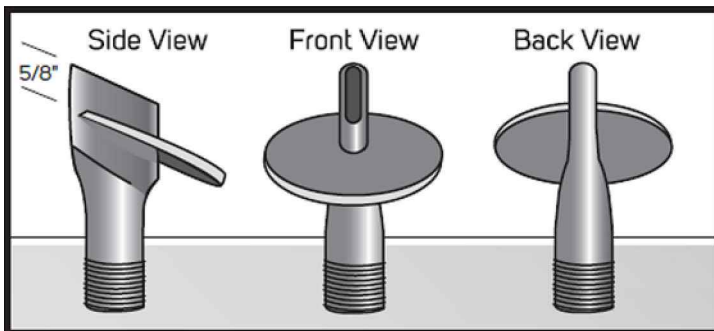

PROPER ADHESIVE APPLICATION

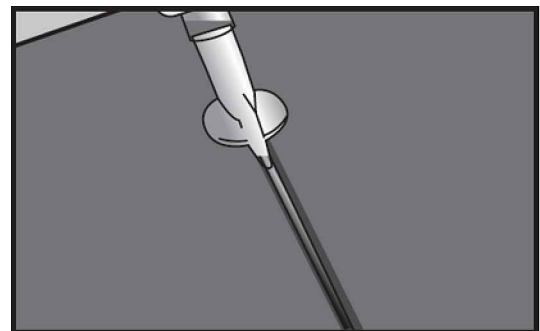

- EPDM/TPO/PVC
- 0** SEE NOTE(S)
- HP PROTECTIVE MAT
- 300HV PROTECTION FABRIC

RUBBER PAVER JOINT ADHESIVE APPLICATION	
PAVER DETAILS	DETAIL NO.
	PDI R4.1

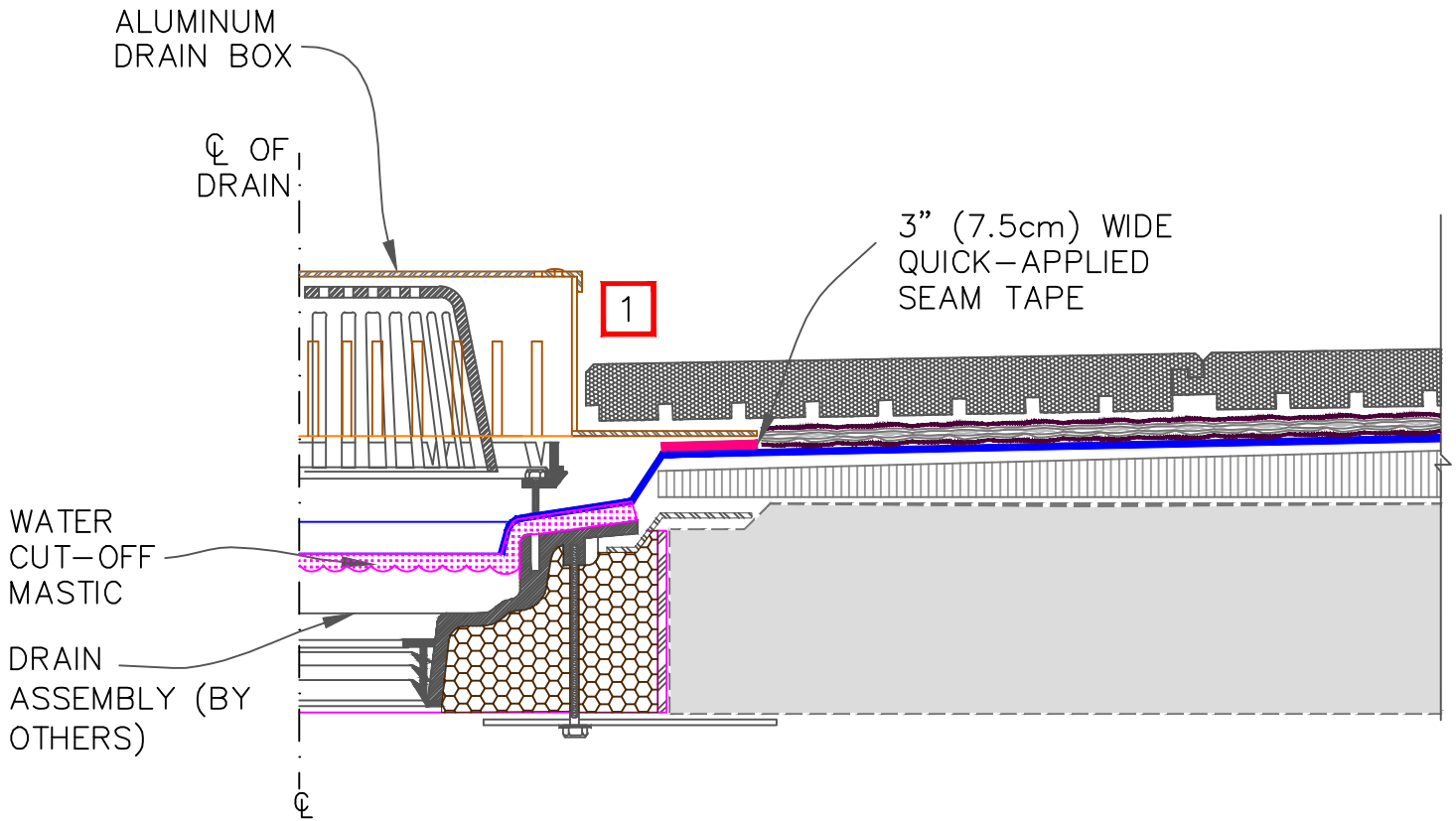

NOTE:

1. RUBBER PAVERS SHOULD BUTT TIGHTLY TO DRAIN BOXES TO MAINTAIN COMPRESSION.



- EPDM/TPO/PVC
- 0 • SEE NOTE(S)
- HP PROTECTIVE MAT
- 300HV PROTECTION FABRIC

DRAIN DETAIL RUBBER PAVER	
PAVER DETAILS	DETAIL NO. PDI R6.1

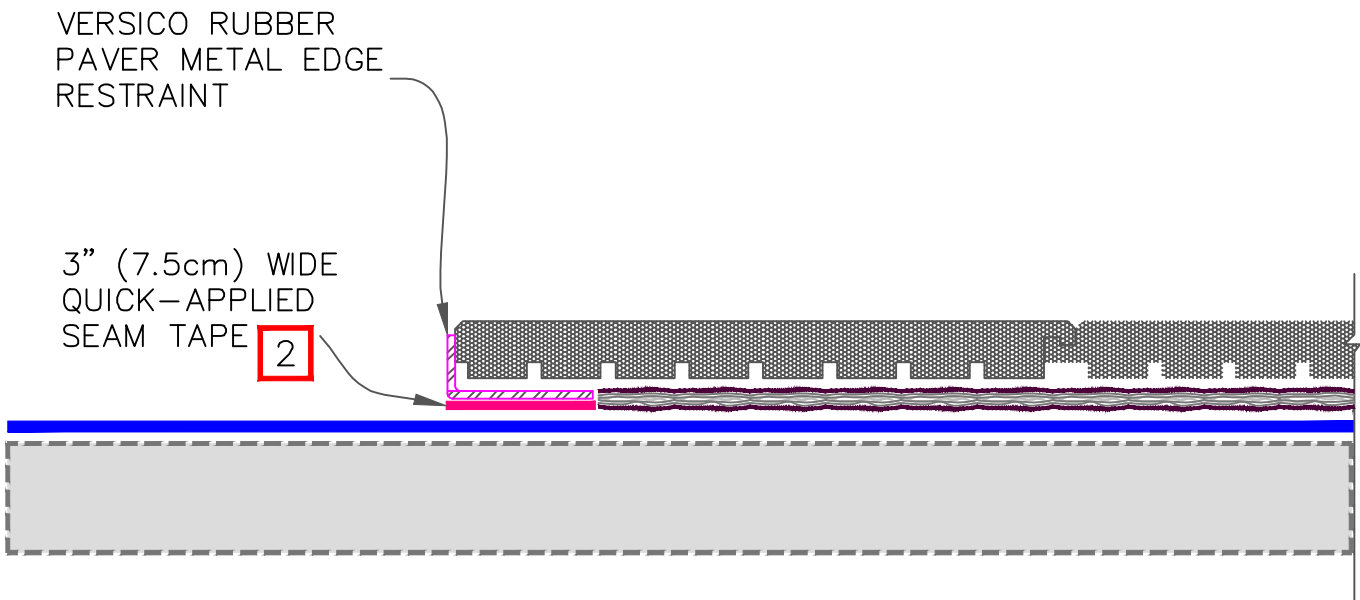

NOTES:

1. RUBBER PAVER EDGE RESTRAINT SHOULD BE USED TO TERMINATE THE RUBBER PAVERS WHEN NOT BUTTED TO A PARAPET WALL OR FIXED CURB
2. RUBBER PAVER EDGE RESTRAINT IS ADHERED TO MEMBRANE USING APPLICABLE PRIMER AND QUICK-APPLIED SEAM TAPE. QUICK-APPLIED SEAM TAPE SHALL EXTEND 1/4" (1cm) BEYOND EDGE OF METAL EDGE TO PROTECT ROOF MEMBRANE FROM METAL BURRS & CORNERS



- EPDM/TPO/PVC
- SEE NOTE(S)
- HP PROTECTIVE MAT
- 300HV PROTECTION FABRIC



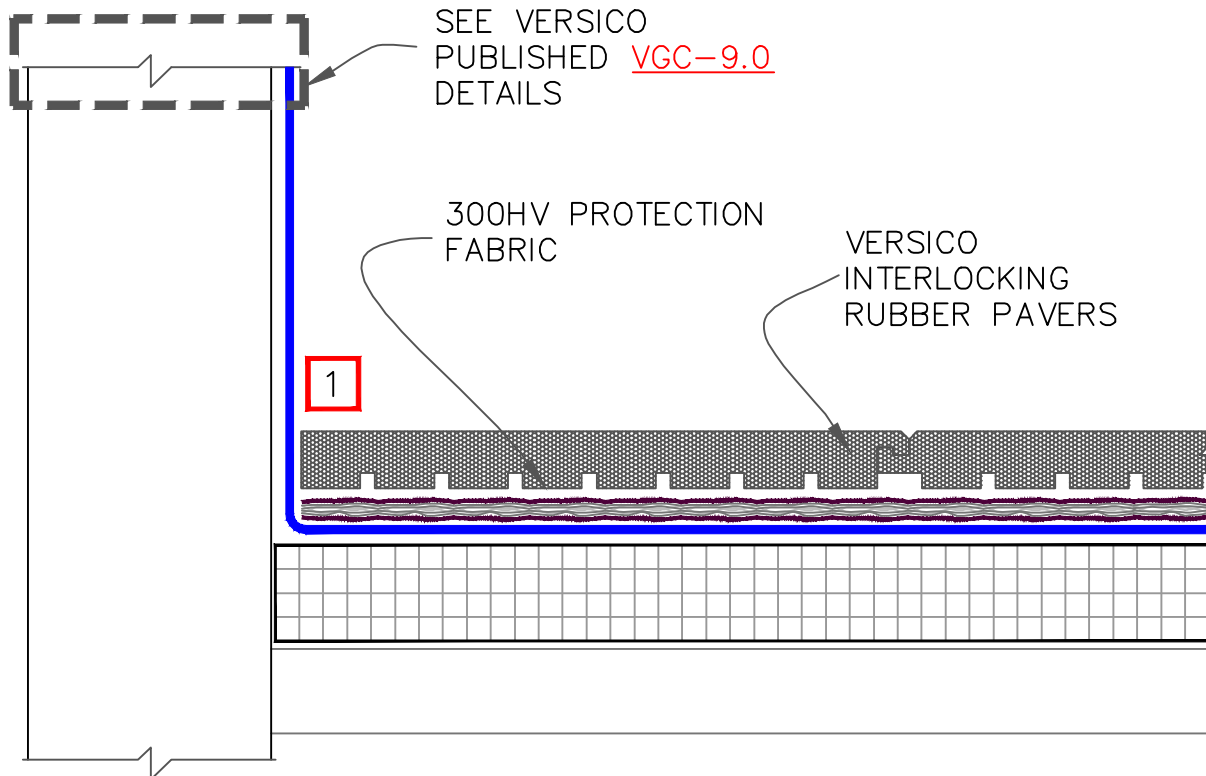

HORIZONTAL TERMINATION AESTHETIC OPTION	
PAVER DETAILS	DETAIL NO. PDIR12.3



NOTE:

1. RUBBER PAVERS SHOULD BUTT TIGHTLY TO PARAPET WALLS. REFER TO VERSICO'S RUBBER PAVER INSTALLATION GUIDE FOR MORE INFORMATION.



-  • EPDM/TPO/PVC
-  • SEE NOTE(S)
-  • HP PROTECTIVE MAT
-  • 300HV PROTECTION FABRIC

PARAPET WALL TERMINATION	
PAVER DETAILS	DETAIL NO. PDIR12.4

