



EPDM FIELD GUIDE



EPDM FIELD GUIDE

FIELD GUIDE PURPOSE

This manual has been developed to serve as a reference guide during the roof installation for Carlisle's approved applicators, quality assurance personnel or anyone involved during the rooftop installation activities. Anyone using the reference guide shall already be familiar with our roofing systems and responsible for actual roof installation.

The following pages include system descriptions, product information, installation procedures, and quality control information to complete a successful EPDM single-ply roof system installation.

Specifications



Details



DISCLAIMER

This manual is offered as a supplement, not a substitute to the Specification Manual, Safety Data Sheets, or Product Data Sheets.

Please visit Carlisle SynTec Systems website for all the latest product information and installation details.

When Installing a Carlisle warranted system, refer to your roof drawing for your project's exact requirements. Should you have questions regarding the roof system, contact information is available in the back of this guide.

TABLE OF CONTENTS

Description of Systems	1
Products & Accessories	
Insulation.....	3
Fasteners & Plates.....	9
Adhesives, Primers, & Sealants.....	13
EPDM Accessories	21
Tools & Equipment	23
Common Installation Issues	24
Staging & Storage Best Practices	25
Execution / Installation Procedures	
Part I – General	27
Part II – Products.....	41
Part III – Execution.....	57
Daily Procedures	85
Insulation Details	90
A-27A Carlisle Insulation / Cover Board Attachment	90
A-27B Minimum 2"-Thick Carlisle / InsulBase® / SecurShield™ Polyisocyanurate Insulation	91
A-27C Minimum 1½"-Thick Carlisle / InsulBase / SecurShield Polyisocyanurate Insulation	92
A-27D ¼" - or ½"-Thick Securock or DensDeck® Prime	93
A-27E ⅝"-Thick SECUROCK® or DensDeck Prime.....	94
A-27F Carlisle StormBase® (OSB/Polyisocyanurate Composite Attachment).....	95
A-27G Insulation / Cover Board Attachment Using Bead Adhesive	96
MF-27 Insulation / Cover Board Attachment For All Warranty Durations	97
MF-27C R-Tech® Fanfold Roof Underlayment.....	98
MF-27D R-Tech Fanfold Roof Underlayment for FM Assemblies	99
MF-27E Insulation/Coverboard Attachment when Using SecurShield Family Products for All Warranty Lengths.....	100
Main Details	101
Ballasted Details	
B-1A Carlisle SecurEdge™ 200.....	101
B-3A Deck-to-Deck Expansion Joint	102
Mechanically Fastened Details	
MF-1A SecurEdge 200.....	103
MF-2.1 Mechanically Fastened EPDM Securement- Option 1	104
MF-2.2 Mechanically Fastened EPDM Securement- Option 2 (RUSS)	105
MF-2.3 Mechanically Fastened EPDM Securement- Option 3 (RUSS)	106
MF-2A Mechanically Fastened EPDM Membrane Splice	107
MF-2A.1 Mechanically Fastened EPDM Membrane Splice (25/30 Year Warranties)	108
MF-2B Mechanically Fastened EPDM Membrane Splice Intersection	109
MF-2B.1 Mechanically Fastened EPDM Membrane Splice Intersection (25/30 Year Warranties)	110
MF-2D End Lap Splice	111
MF-6B Roof Drain with Sump.....	112
MF-8A Pressure-Sensitive Pipe Seal	113
MF-8A.1 Pressure-Sensitive Pipe Seal with 20" Pressure-Sensitive Cured Flashing	114
MF-8B Field Fabricated Pipe Wrap	115
MF-8B.1 Field Fabricated Pipe Wrap (25/30 Year Warranties)	116
MF-22 Ridge Membrane Attachment	117
Universal Details	
U-1A Carlisle SecurEdge 200	118
U-1A.1 Carlisle SecurEdge 200 (25/30 Year Warranties)	119

U-1B Carlisle SecurEdge 300.....	120
U-1B.1 Carlisle SecurEdge 300 (25/30 Year Warranties)	121
U-1C Carlisle SecurEdge 2000 & 3000.....	122
U-1D SecurEdge Drip Edge Fascia	123
U-1D.1 SecurEdge Drip Edge Fascia (25/30 Year Warranties)	124
U-1E SecurEdge One-Piece Gravel Stop	125
U-1F Metal Bar Edge Termination.....	126
U-2A EPDM Membrane Splice.....	127
U-2A.1 EPDM Membrane Splice (25/30 Year Warranties)	128
U-2B EPDM Membrane Splice Intersection.....	129
U-2B.1 EPDM Membrane Splice Intersection (90-mil Membrane or 25/30 Year Warranties)	130
U-2C EPDM Membrane Splices at Angle Change	131
U-3A Deck-to-Deck Expansion Joint	132
U-3B Deck-to-Wall Expansion Joint	133
U-3C Shear/Expansion Joint.....	134
U-5A Curb Flashing- EPDM Membrane	135
U-5B Curb Flashing- Pressure-Sensitive Curb Wrap with 6" Tape.....	136
U-5C Curb Flashing with 20" Pressure-Sensitive Cured Flashing.....	137
U-5D Self-Flashing Curb	138
U-5E New Self-Flashing Metal Curb	139
U-6A Roof Drain.....	140
U-6B Roof Drain- Reinforced Field Sheet with Sump Exceeding 3" per Foot	141
U-6C Sure-Seal Insert Drain.....	142
U-6D Insert Drain Through Deck	143
U-6E Sure-Seal Add-On Drain	144
U-8A Pressure-Sensitive Pipe Seal.....	145
U-8A.1 Pressure-Sensitive Pipe Seal (90-mil Membrane or 25/30 Year Warranties)	146
U-8B Field Fabricated Pipe Wrap	147
U-8B.1 Field Fabricated Pipe Wrap (25/30 Year Warranties)	148
U-8C Flexible Penetration.....	149
U-8C.1 Flexible Penetration (25/30 Year Warranties)	150
U-8D Field Fabricated Hot Stack	151
U-8D.1 Field Fabricated Hot Stack (25/30 Year Warranties)	152
U-9 Membrane Terminations (1 of 2)	153
U-9 Membrane Terminations (2 of 2).....	154
U-12A Parapet/Curb with Continuous Membrane	155
U-12B Parapet/Curb with Separate Membrane Flashing.....	156
U-13A Built-Up Roofing Tie-In Over Steel Roof Deck.....	157
U-13B Built-Up Roofing Tie-In Over Concrete Roof Deck	158
U-13C Tie-In to Existing EPDM Membrane	159
U-13D EPDM Tie-In Over Concrete Deck	160
U-13E Tie-In Shingled or Metal Panel Roof.....	161
U-13F Tie-In Between New Carlisle Adhered & Ballasted Roof.....	162
U-13G Tie-In Between New Carlisle Mechanically Fastened & Ballasted Roof.....	163
U-15A Inside Corner Wall Flashing with RUSS (Option 1)	164
U-15B Inside Corner Wall Flashing with RUSS (Option 2)	165
U-15C Inside Corner with Continuous EPDM Wall Flashing	166
U-15D Inside Corner with Separate EPDM Wall Flashing.....	167
U-15D.1 Inside Corner Flashing (90-mil Membrane or 25/30 Year Warranties)	168
U-15E Outside Corner with Pre-Cut Pressure-Sensitive Corner.....	169
U-15F Outside Corner with Pressure-Sensitive Elastoform Flashing (2 Piece).....	170
U-15G Outside Corner with Pressure-Sensitive Elastoform Flashing (1 Piece).....	171
U-15G.1 Outside Corner Flashing (90-mil Membrane or 25/30 Year Warranties)	172
U-16A Pressure-Sensitive Pourable Sealer Pocket.....	173
U-16A.1 Pressure-Sensitive Pourable Sealer Pocket (25/30 Year Warranties)	174

U-16B Field Fabricated Pourable Sealer Pocket.....	175
U-16B.1 Field Fabricated Pourable Sealer Pocket (25/30 Year Warranties).....	176
U-16C Extended Pourable Sealer Pocket	177
U-16C.1 Extended Pourable Sealer Pocket (25/30 Year Warranties)	178
U-18A Metal Scupper at Deck.....	179
U-20A Lightning Rod at Parapet (Vertical Attachment).....	180
U-20B Lightning Rod at Deck Level.....	181
U-22 Valley	182
U-24 Sleeper	183
U-30 I-Beam Penetration	184
SAT Details	
SAT-2A SAT EPDM Membrane Splices.....	185
SAT-12A Parapet / Curb with Continuous Membrane- RUSS.....	186
SAT-12B Parapet / Curb with Separate Regular EPDM Flashing.....	187
SAT-12C Parapet / Curb with Separate SAT EPDM.....	188
SAT-12D Parapet / Curb with Continuous Membrane- Cover Strip.....	189
Liquid Flashing Details	190
Attachment 1- Inspection, Cleaning & Substrate Preparation (Page 1 of 2)	193
Attachment 1- Inspection, Cleaning & Substrate Preparation (Page 2 of 2)	194
Attachment 2- Application of LIQUISEAL Primer & Resin	195
LF-1.1 Sheet Metal Drip Edge or Gravel Stop Flashing	196
LF-8.1 Single or Multiple Pipe Penetrations (Page 1 of 2)	197
LF-8.1 Single or Multiple Pipe Penetrations (page 2 of 2).....	198
LF-13.1 EPDM Membrane Tie-in with Existing Roof over Steel Deck	199
LF-13.2 TPO or PVC Membrane Tie-In With Existing Roof Over Steel Deck (1 of 2).....	200
LF-13.2 TPO or PVC Membrane Tie-In With Existing Roof Over Steel Deck (2 of 2).....	201
LF-13.3 Membrane Tie-in with Existing Roof over Concrete Deck.....	202
LF-18.1 Through-Wall Scupper	203
LF-30.1 Steel I-Beam Flashing (Page 1 of 2)	204
LF-30.1 Steel I-Beam Flashing (Page 2 of 2).....	205
VacuSeal Details	206
V-0.1 Roof Assembly Over Existing Single-Ply Roof	206
V-0.2 Roof Assembly Over Existing Asphaltic Roof	207
V-0.3 Roof Assembly Over Steel Deck	208
V-0.4 Roof Assembly Over Poured-in-Place Concrete Deck	209
V-0.5 Roof Assembly Over Concrete Planks.....	210
V-0.6 Roof Assembly Over Lightweight Concrete Deck.....	211
V-0.7 Roof Assembly Over Wood Deck	212
V-1.1 Roof Edge: Roof Recover	213
V-1.2 Roof Edge: Tear-Off & Reroofing.....	214
V-5.1 Curb Base Flashing - New Construction and Re-Roof (Recover)	215
V-6.1 Roof Drain: Re-Roof (Recover)	216
V-6.2 Roof Drain: New Construction	217
V-8.0 VacuSeal™ Vent with Pre-Applied Skirt Flashing.....	218
V-8.1 Pipe/Structural Steel Tube Through Metal Deck.....	219
V-8.2 Multiple Penetrations Through Steel Deck - New Construction	220
V-8.3 Single Penetration Through Existing Roof Assembly	221
V-8.4 Cluster of Penetrations Through Existing Roof Assembly	222
V-8.5A Hot Stack Air Flashing - Option A	223
V-8.5B Hot Stack Air Flashing - Option B.....	224
V-12.1 Parapet with Membrane Air Barrier.....	225
V-12.2 Parapet/Curb: Concrete/Lightweight Concrete Used as an Air Barrier	226
V-12.3 Parapet or Wall - New Construction and Re-Roof (Recover).....	227
Contact Information	228

SECTION 1: DESCRIPTION OF SYSTEMS

SURE-SEAL® / SURE-WHITE® / SURE-TOUGH® EPDM

Sure-Seal, Sure-White, and Sure-Tough EPDM Adhered Roofing System

- Black and White Membrane Colors Available
- Standard Widths: 10', 16.5', and 20'
- Standard Lengths: 50' and 100'
- Kleen and Dusted Membrane Available
- 3" or 6" Factory-Applied Tape (FAT™)

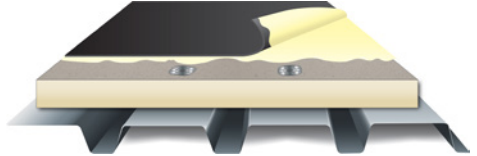

Sure-Seal, Sure-White, and Sure-Tough EPDM SAT™ (Self-Adhering Technology) Roofing System

- Black and White Membrane Colors Available
- Standard Width: 10'
- Standard Lengths: 50' and 100'
- Standard Thickness: 60-mil
- 3" Factory-Applied Tape (FAT)

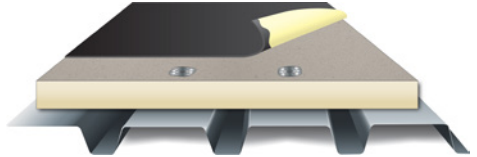

Sure-Tough EPDM Mechanically Fastened Roofing System

- Black Reinforced Membrane Only
- Standard Widths: 6.5' 8', and 10'
- Standard Lengths: 50' and 100'
- Kleen Membrane Only
- 6" Factory-Applied Tape (FAT)

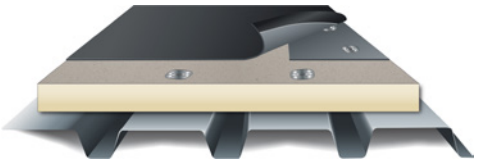

Sure-Seal, Sure-White, and Sure-Tough EPDM VacuSeal Roofing System

- Black and White Membrane Colors Available
- Standard Widths: 10', 16.5' and 20'
- Standard Lengths: 50' and 100'
- Kleen and Dusted Membrane Available
- 3" or 6" Factory-Applied Tape (FAT)



Sure-Seal and Sure-Tough EPDM Ballasted Roofing System

- Black Color Only
- Standard Widths: 30', 40', and 50'
- Standard Lengths: 50' and 100'

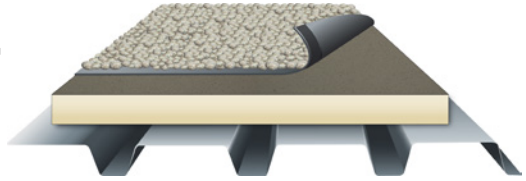

Sure-Seal, Sure-White, and Sure-Tough EPDM Metal Retrofit Fully Adhered Roofing System

- Black and White Membrane Colors Available
- Standard Widths: 10', 16.5', and 20'
- Standard Lengths: 50' and 100'
- Kleen and Dusted Membrane Available
- 3" or 6" Factory-Applied Tape (FAT)

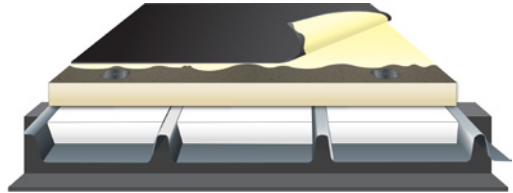

Sure-Tough EPDM Metal Retrofit Mechanically Fastened Roofing System

- Black Reinforced Membrane Only
- Standard Widths: 6.5', 8', and 10'
- Standard Lengths: 50' and 100'
- Kleen Membrane Only
- 6" Factory-Applied Tape (FAT)

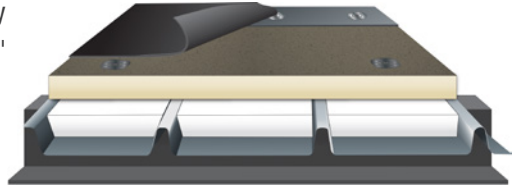

SECTION 2: PRODUCTS & ACCESSORIES

Insulation



SecurShield with ReadyFlash Technology

A rigid roof insulation panel composed of a closed-cell polyisocyanurate foam core bonded to high performance **coated glass facers (CGF)**. ReadyFlash features a dark CGF to accelerate adhesive flash-off on one side of the insulation board and a light CGF to slow down adhesive flash-off on the other. Ideal for use in adhered membrane systems. Provides a direct to combustible deck UL Class A fire rating at 1" thickness.

Sizes: 4' x 4' and 4' x 8'

Thicknesses: ½" to 4 ½"

Compressive Strengths: 20 and 25 psi

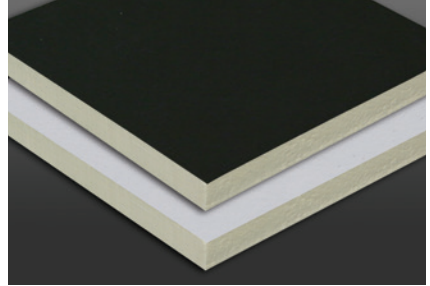

SecurShield HD with ReadyFlash Technology

A rigid roof insulation panel composed of ½" high-density, closed-cell polyisocyanurate foam core bonded to a premium performance **coated glass facer (CGF)** specifically designed for use as a cover board. ReadyFlash features a dark CGF to accelerate adhesive flash-off on one side of the insulation board and a light CGF to slow down adhesive flash-off on the other. Provides 5 times the R-value at one-fifth the weight of traditional gypsum cover boards. Achieves a UL Class A fire rating direct to combustible deck.

Sizes: 4' x 4' and 4' x 8'

Thickness: ½"

Compressive Strength: 109 psi max

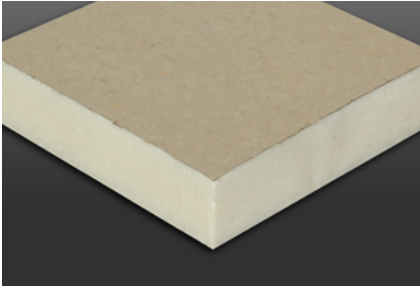

InsulBase Polyiso

A rigid roof insulation panel composed of a closed-cell polyisocyanurate foam core bonded to **glass-reinforced felt (GRF) facers**. UL and FM approved for direct application over steel decks, polyiso provides the highest R-value per inch of any commercially available insulation product.

Sizes: 4' x 4' and 4' x 8'

Thicknesses: ½" to 4 ½"

Compressive Strengths: 20 and 25 psi



StormBase Polyiso

A rigid roof insulation composite panel composed of a closed-cell polyisocyanurate foam core bonded to a glass-reinforced felt (GRF) facer on one side and ¼" **oriented strand board (OSB)** on the other.

Sizes: 4' x 4' (routed 3 sides) and 4' x 8' (routed 4 sides)

Thicknesses: 1 ½" to 4 ½"

Standard Thickness: 1 ½", 2", 2 ½", 3", and 4"

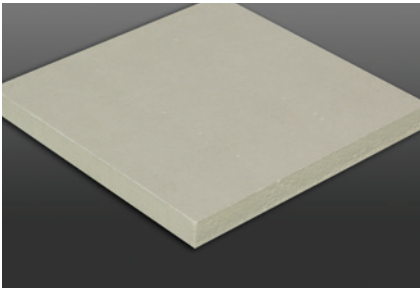

SecurShield HD Plus

A rigid roof insulation panel composed of a ½" high-density, closed-cell polyisocyanurate foam core bonded to a premium performance coated glass facer (CGF) specifically designed for use as a cover board. Enhanced performance of the HD Plus product provides a **FM 1-90 wind uplift rating with only 8 fasteners**.

Sizes: 4' x 4' and 4' x 8'

Thickness: ½"

Compressive Strength: 109 psi max

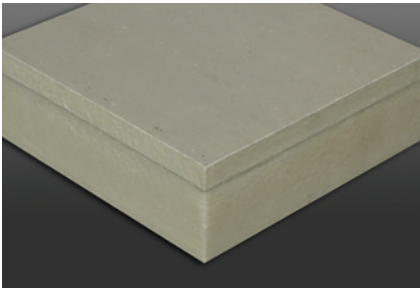

SecurShield HD Composite

A unique composite insulation panel comprised of ½" high-density polyiso cover board bonded during the manufacturing process to SecurShield rigid polyiso roofing insulation. Eliminates the need for a separate cover board, reduces inter-ply adhesives and saves labor on the roof. **A single product solution.**

Sizes: 4' x 4' and 4' x 8'

Thicknesses: 1 ½" to 4 ½"

Compressive Strengths: 20 psi (SecurShield) or 109 psi max (SecurShield HD)

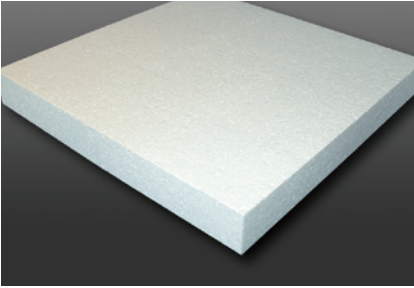

Carlisle EPS

Engineered rigid insulation made of high-performance, water-resistant expanded polystyrene (EPS). Meets ASTM C578 requirements, includes extensive UL and FM ratings, and can be applied direct to metal decks. Warranted long-term R-value of up to 4.76/inch @ 40°F.

Sizes: 4' x 4' or 4' x 8'; custom sizes and tapered panels available

Thicknesses: ¼" to 40" per panel

Densities: 1 to 3 lb/ft³

Compressive Strength: 10 to 60 lb/ft³

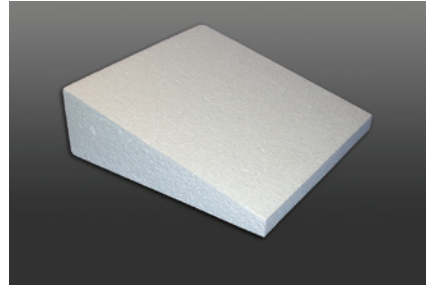

Carlisle Tapered EPS

Tapered engineered EPS insulation available in virtually any slope. Can be combined with Carlisle polyiso for tapered hybrid roof systems. Design assistance is available from Carlisle's Tapered Design Team. Custom saddles and crickets also available.

Slope: Virtually any slope

Thickness: ½" to 40"

Densities: 1 to 3 lb/ft³

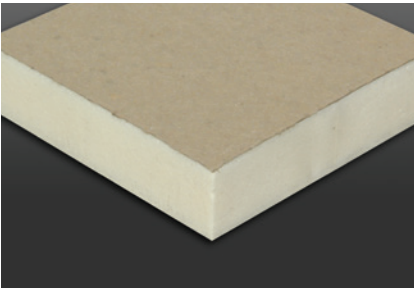

InsulBase NH

InsulBase NH Polyiso is an LBC "Red List Free" rigid roof insulation panel composed of a closed-cell polyisocyanurate foam core bonded on each side to fiber-reinforced paper facers. InsulBase NH contains **zero halogenated flame retardants**.

Sizes: 4' x 4' and 4' x 8'

Thickness: ½" to 4 ½"

Slope: 20 and 25 psi

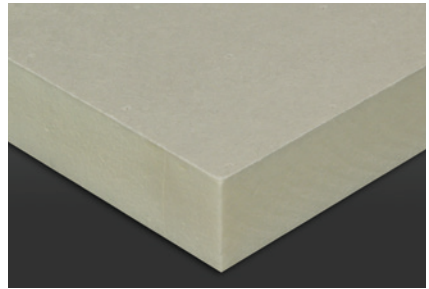

SecurShield NH

SecurShield NH Polyiso is an LBC "Red List Free" rigid roof insulation panel composed of a closed cell polyisocyanurate foam core bonded during the manufacturing process to premium performance coated glass facers (CGF). SecurShield NH contains **zero halogenated flame retardants**.

Sizes: 4' x 4' and 4' x 8'

Thickness: ½" to 4 ½"

Slope: 20 and 25 psi

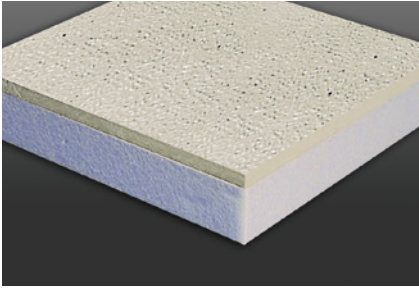

Carlisle HD EPS Composite

High-density polyiso cover board (½") laminated to Carlisle's engineered EPS. Five times lighter than traditional cover boards. Approved for both adhered and mechanically attached systems. Provides enhanced protection against severe weather and hail and meets Title 24 requirements for continuous insulation on combustible decks.

Sizes: 4' x 4' or 4' x 8'; custom sizes and tapered panels available

Thickness: 1 ½" to 7" (including ½" HD polyiso cover board)

Densities: 1 to 3 lb/ft³

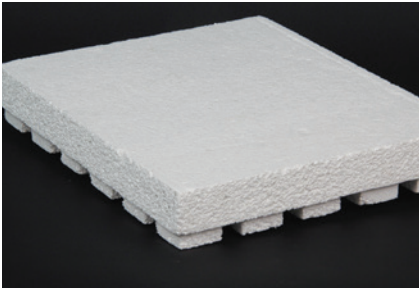

ChannelDry®

Carlisle's high-performance ChannelDry insulation is composed of lightweight, closed-cell expanded polystyrene meeting the requirements of ASTM C578 Type IX. ChannelDry has excellent dimensional stability, compressive strength, and water-resistant properties. ChannelDry is designed to be mechanically fastened directly to concrete decks. The use of ChannelDry in conjunction with one-way and two-way relief vents allows the installation of the roof system to begin upon structural cure of concrete.

Sizes: 4' x 4'

Thickness: 2"

Compression Strength: 25 psi

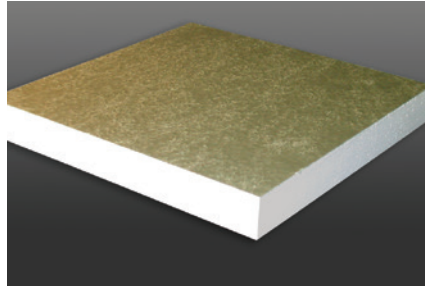

Carlisle SP EPS

Premium coated-glass-faced insulation approved for mechanically attached or self-adhering systems without a slip sheet. Warranted long-term R-value provides up to R-30 in a single layer.

Sizes: 4' x 4' or 4' x 8'; custom sizes and tapered panels available

Thicknesses: ¼" to 6"

Densities: 1 ¼ to 3 lb/ft³

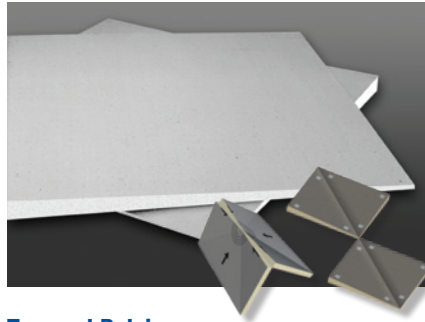

Tapered Polyiso

A sloped, rigid roof insulation panel composed of a closed-cell polyisocyanurate foam core bonded to a coated glass or fiber-reinforced facer. Designed to promote **positive drainage** and **prevent ponding water**.

Hinged Target Sumps and Pre-Cut Hips and Valleys ship ready to install, **require no field cuts and save valuable time on the roof**. Multiple thicknesses and slopes available to accommodate specific job conditions with no waste, thus reducing disposal fees.

Sizes: 4' x 4' and 4' x 8' 4' x 4' (Sump)
4' x 4' (Hip/Valley) 8' x 8' (Sump)

Thicknesses: ½" to 4 ½" (multiple layers utilized for increased thicknesses)

Compressive Strengths: 20 and 25 psi

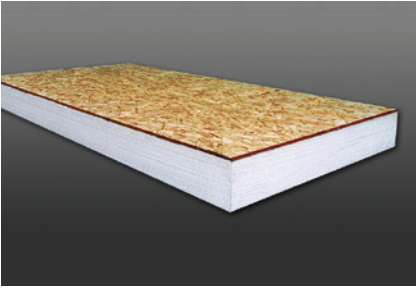

Carlisle InsulLam™

OSB, plywood, or gypsum board laminated to Carlisle's engineered EPS. Approved for both adhered and mechanically attached systems. Provides enhanced protection against severe weather and hail. Can be utilized as a nail base, is available vented and with a wide assortment of cover boards.

Sizes: 4' x 4' or 4' x 8'

Thickness: 1½" to 7"

Laminate: OSB 7/16" and 5/8"; plywood 5/8"; gyp. thickness varies

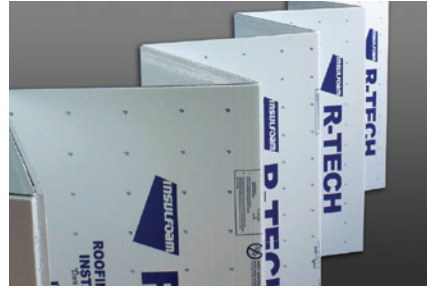

R-Tech Fanfold Recover Board

High-performance water-resistant facers laminated to Carlisle engineered EPS. Code-approved for recover applications and compatible with both light- and dark-colored single-ply membranes. Five times lighter than traditional cover boards with a coverage rate of 200 sq. ft. Saves time and labor on the roof.

Sizes: 2' x 4' (folded), 4' x 50' (unfolded)

Thicknesses: ¼", ⅜", ½", ¾"

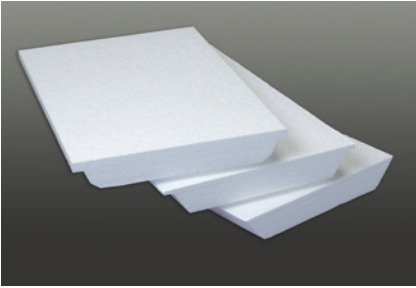

Carlisle EPS Flute-fill

Custom-cut, engineered EPS flute-fill insulation manufactured for virtually any standing seam profile. Meets ASTM C578 requirements and includes extensive UL and FM ratings, including direct to metal deck installations.

Thickness, Shape and Size: Custom manufactured to fit any roof profile

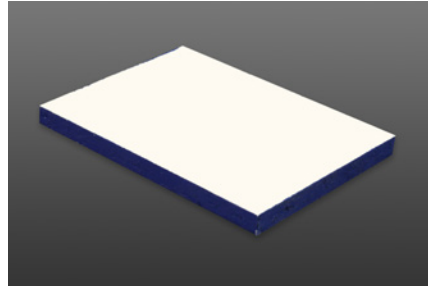

EcoStorm VSH™

Engineered composite building material made from a proprietary blend of plastic and cellulose fiber sourced from post-industrial and post-consumer waste streams.

Sizes: 4' x 4' and 4' x 8'

Thickness: ½"

Compressive Strength: 3990 psi

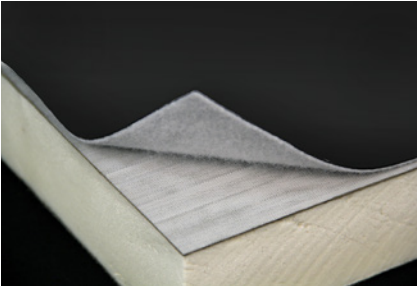

InsulBase RL

InsulBase RL is a standard density polyisocyanurate roof boards specially designed to act as the hook in the RapidLock (hook and loop) system. InsulBase RL utilizes a GRF facer and SecurShield RL a CGF facer.

Size: 4' x 8'

Thickness: 2.0" and 2.6"

Compressive Strengths: 20 psi

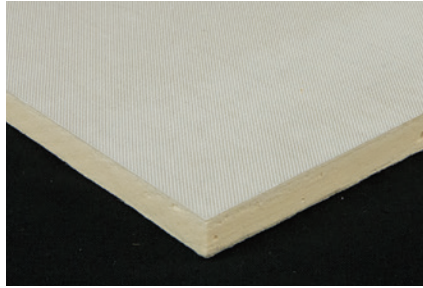

SecurShield HD RL

SecurShield HD RL is a high-density rigid roof polyisocyanurate board bonded to coated-glass (CGF) facers specially designed to act as the hook in the RapidLock (hook and loop) system.

Sizes: 4' x 8'

Thickness: ½"

Compressive Strength: 109 psi max



SecurShield HD Composite RL

SecurShield HD Composite RL is a rigid roof insulation panel composed of a top layer of high-density, closed-cell foam, and a bottom layer of 20 psi closed-cell foam, specifically designed to act as the hook in the RapidLock system. This creates a single-component solution that eliminates the need for a coverboard.

Sizes: 4' x 8' and 4' x 4'

Thickness: 2.0" to 4.0"

Compressive Strength: 20 psi (SecurShield)
and 109 psi max (SecurShield HD)

Fasteners & Plates

Insulfast™ Fastener



Can be used to secure insulation. Compatible with wood (minimum $\frac{1}{32}$ " [12mm] CDX plywood) and steel decks (22-gauge [0.76 mm] or heavier).

Sizes Available:

$\frac{1}{8}$ " , 2" , $2\frac{1}{4}$ " , 3" - 8" (1" increments)

Size & Quantity Per Box:

$\frac{1}{8}$ " , $2\frac{1}{4}$ " , 2" - 8": 1,000

HP-X Fastener™ & HP-XTRA Fastener



Can be used to secure membranes, RUSS, and insulation. Compatible with wood (minimum $\frac{1}{32}$ " [12mm] CDX plywood) and steel decks (22-gauge [0.76 mm] or heavier).

Sizes Available:

2" – 8" (1" Increments)
10" – 16" (2" Increments)

Size & Quantity Per Box:

2" – 4": 1,000; 5" – 12": 500;
14" – 16": 250

HP-XTRA Fastener

Also available (not shown)

A #21 diameter fastener compatible with wood (minimum $\frac{1}{32}$ " [12mm] CDX plywood) and steel decks (22-gauge [0.76 mm] or heavier).

Sizes Available:

2" – 8" (1" increments)

Size & Quantity Per Box:

500 (2" – 6"), 250 (7" – 8")

ASAP Insulfast Fastener & Plate



A pre-assembled InsulFast fastener and plastic or metal insulation plate is acceptable for insulation attachment in both mechanically attached and fully adhered applications.

Can be used to secure insulation. Compatible with wood (minimum $\frac{1}{32}$ " [12mm] CDX plywood) and steel decks (22-gauge [0.76 mm] or heavier). Longer fastener sizes available through special order.

Sizes Available:

$2\frac{1}{4}$ " , 3" – 8" (1" Increments)

Size & Quantity Per Box:

$2\frac{1}{4}$ " – 8": 250

Applications requiring a fastener larger than 8" should use HD 14-10 fasteners.

HD 14-10 Fastener



Can be used to secure membranes, RUSS, and insulation. Compatible with wood (minimum $\frac{1}{32}$ " [12mm] CDX plywood) and structural concrete (minimum 2,500 psi).

Sizes Available:

2" – 12" (1" Increments)
14" – 24" (2" Increments)

Size & Quantity Per Box:

2" – 4": 1,000; 5" – 11": 500;
12" – 24": 250

GypTec Fastener & Plate



Can be used to secure membranes, RUSS, and insulation. Applicable to cementitious wood fiber, lightweight concrete and gypsum decks.

Sizes Available:
2½"– 10" (½" Increments)

Size & Quantity Per Box:
2½"– 7": 500; 7½"– 10": 250

Gyptec Plate



Sizes Available:
2" Metal membrane plate
3" Metal insulation plate

Quantity Per Box: 1,000

HP-X ASAP



A pre-assembled HP-X fastener and Piranha Plate™. Can be used to secure membranes, RUSS, and insulation. Compatible with wood (minimum 1½" [12mm] CDX plywood) and steel decks (22-gauge [0.76 mm] or heavier).

Sizes Available:
2"–10" (1" Increments)
12"–16" (2" Increments)

Size & Quantity Per Box:
2"– 9": 250; 10"– 12": 200;
14"– 16": 150

Polymer Pre-Assembled



A pre-assembled HP Fastener and Polymer Seam Plate applicable for wood (minimum 1½" [12mm] CDX plywood) and steel decks (22-gauge [0.76 mm] or heavier).

Sizes Available:
2"– 12" (1" Increments)

Size & Quantity Per Box:
2": 500; 3": 450; 4"and 5": 400;
6": 350; 7"and 8": 300; 9": 250;
10"– 12": 200

CD-10 Fastener



Can be used to secure membranes, RUSS, and insulation. Compatible with structural concrete decks (minimum 2,500 psi).

Sizes Available:
2"– 6" (½" Increments)
7"– 12" (1" Increments)

Size & Quantity Per Box:
2"– 8": 500; 9"– 12": 250

HP Lite-Deck Fastener



Used in conjunction with a specially designed 3" Lite-Deck Metal Plate for Insulation attachment to gypsum, cementitious wood fiber (Tectum). Features an oversize diameter (0.312" shank) and a deep, coarse thread designed for high pullout resistance.

Sizes Available:
2½", 3"– 10", 12" (1" Increments)

Size & Quantity Per Box:
2½"– 4": 500; 5"– 8": 250;
9", 10", 12": 125

HP Fasteners



Can be used with various Carlisle fastening plates to secure membrane, insulation, and Pressure-Sensitive (PS) RUSS strips to a variety of substrates. Specially designed for securement of membrane on Carlisle's Sure-Tough mechanically fastened systems, Carlisle's HP Fasteners are compatible with 22-gauge and heavier steel, CDX plywood, and wood plank deck types.

Sizes Available:
1¼", 2" – 15" (1" increments)

Size & Quantity Per Box:
1¼", 2" – 6": 1,000

7" – 12": 500

13" – 15": 250

Purlin Fastener



Used with Carlisle's Metal Retrofit Roofing System to secure membrane and RUSS to structural steel purlins. Provides superior back-out resistance in standard 16-gauge Purlins.

Sizes Available:
3¾", 4¾", 5¾", 7", 8"

Quantity Per Box: 1,000

RetroDriller Fastener



A specially designed fastener with a ½" drill point used for attaching single-ply membranes to structural steel purlins (up to ¾") in standing seam metal roof retrofit applications.

Sizes Available:
4", 5", 6", 8" & 10"

Size & Quantity Per Box: 500

Lite-Deck Metal Plate



Used in conjunction with HP Lite-Deck Fasteners for insulation attachment to gypsum, cementitious wood fiber (Tectum).

Sizes Available:
3" diameter

Quantity Per Box: 500

SecurFast™ Insulation Fastening Plate



Designed for SECUROCK securement under single-ply membranes. Plates are stamped from Galvalume-coated steel for long-term protection against corrosion.

Sizes Available: 2 7/8"

Quantity Per Box: 1,000

AccuTrac Plate (Insulation)



AccuTrac Plates are 3" square flat- or recessed-bottom plates made of Galvalume-coated steel. Used to fasten insulation with the AccuTrac Tool.

Sizes Available: 3"

Quantity Per Box: 1,000

Term Bar Nail-In



Used with Carlisle's Termination Bar or Seam Fastening Plates to secure membrane to concrete block, brick, or structural concrete walls. A zinc-plated steel pin provides excellent corrosion resistance while the zinc alloy body provides excellent holding power.

Sizes Available: 1¼"

Quantity Per Box: 1,000

Insulation Fastening Plate



Used for insulation securement over wood (minimum 1½" [12mm] CDX plywood), steel (22-gauge [0.76 mm] or heavier), and concrete decks. Available in steel and plastic versions.

Sizes Available:
3" diameter

Quantity Per Box: 1,000

Seam Fastening Plate



Can be used with HP, HD 14-10, and CD-10 Fasteners to mechanically attach all Sure-Seal membranes and RUSS (excluding steel decks).

Sizes Available: 2"

Quantity Per Box: 1,000

HP Polymer Seam Plate



Used in conjunction with HP Fasteners to mechanically fasten Sure-Tough membrane and RUSS over steel decks. (22-gauge [0.76mm] or heavier)

Sizes Available: 2"

Quantity Per Box: 1,000

Also Available (Not Shown):

HP-XTRA Polymer Seam Plate

Used in conjunction with HP Fasteners to mechanically fasten Sure-Tough membrane and RUSS over steel decks. (22-gauge [0.76mm] or heavier)

Sizes Available: 2 3/8"

Quantity Per Box: 1,000

Termination Bar (Aluminum)



Extruded aluminum bar that is designed for securing and sealing compression type flashing terminations. The bar features a top edge for ease of applying Carlisle's Lap Sealant. The bar can be easily cut to any desired length.

Sizes Available:
1" wide x 10' long

Quantity Per Box: 50 pcs; 500 Linear Feet

Metal Fastening Bar



GALVALUME®-coated metal bar used to mechanically fasten EPDM membranes. The bar can be easily cut to desired length. Installed using HP-X Fasteners.

Sizes Available: 1" wide x 10' long

Quantity Per Box: 50 pcs;
500 Linear Feet

Dual Prong Fasteners



Designed to secure base sheets over gypsum, fibrous cement, and lightweight concrete decks and consist of a galvanized (G-90) tube, a 2.7"-diameter GALVALUME plate, and a locking staple formed from high-tensile coated steel wire. Dual

Prong Fasteners are installed using Carlisle's stand-up Dual Prong Applicator, which holds and drives the tube into the deck and sets the wires.

Sizes Available: 1.8" (45.17 mm)

Quantity Per Box: 500

Adhesives, Primers, & Sealants

90-8-30A EPDM Bonding Adhesive



A high-strength, solvent-based contact adhesive that allows quick bonding of cured EPDM membranes to various substrates. Designed for bonding Sure-White, Sure-Seal, Sure-Tough, and Epichlorohydrin membranes to approved substrates.

Coverage Rate: 60 square feet per gallon of finished surface.

Packaging: 5-gallon pail

Product Number: 302124

Shelf Life: 12 months

Aqua Base 120 Bonding Adhesive



Aqua Base 120 is a unique, semi-pressure-sensitive, water-based bonding adhesive for EPDM membranes offering good peel strengths with low-VOCs and no strong odors.

Coverage Rate: 120 square feet per gallon of finished surface. (May vary due to conditions such as insulation type or wall construction.)

Packaging: 5-gallon pail

Product Number: 307431

Shelf Life: 12 months

Low-VOC Bonding Adhesive*



A high-strength, solvent-based contact adhesive that allows bonding of all EPDM membranes to various porous and non-porous substrates. This product meets the <250 gpl VOC content requirements of the OTC Model Rule for Single-Ply Roofing Adhesives.

Coverage Rate: 60 square feet per gallon of finished surface.

Packaging: 5-gallon pail

Product Number: 303090

Shelf Life: 12 months

Weathered Membrane Cleaner



Used to clean both new and in-service Sure-Seal, Sure-White, and Sure-Tough EPDM membranes prior to seaming or

application of Pressure-Sensitive (PS) products. Helps to loosen and remove dirt and other contaminants from the surface of the membranes and leaves a suitable surface for application of adhesive or primer. Please refer to the Product Data Sheets for specific instructions for EPDM applications.

Coverage Rate: 400 square feet (one surface) per gallon.

Packaging:
(2) 1-gallon closed-top cans,
5-gallon closed-top pail
1-gallon cans

Product Number: 304066 5-gallon pail

Product Number: 302074 1-gallon pail

* Not compliant in all CA counties

Low-VOC Bonding Adhesive 1168*



A high-strength, solvent-based contact adhesive that allows bonding of all Sure-Seal, Sure-White, and Sure-Tough EPDM membranes to various porous and non-porous substrates. This product meets the requirements for SCAQMD regulations.

Coverage Rate: 60 square feet per gallon of finished surface.

Packaging: 5-gallon pail

Product Number: 318847

Shelf Life: 12 months

X-23 EPDM Bonding Adhesive



A high-strength, solvent-based contact adhesive that bonds EPDM membranes to various porous and non-porous substrates. This product meets the <250 g/L VOC content requirements of the OTC Model Rule for Single-Ply Roofing Adhesives.

Coverage Rate: 60 square feet per gallon of finished surface.

Packaging: 5-gallon pail

Product Number: 324002

Shelf Life: 12 months

Flexible FAST™ Adhesive



A low-rise, two-component, VOC-free, energy-absorbing, impact-resistant adhesive used to adhere FleeceBACK membranes and insulation boards to various substrates for a totally non-penetrating system application. Flexible FAST adhesive provides a wider window of temperature workability (25°F – 120°F).

Coverage Rate: See Product Data Sheet.

Packaging:

50-gallon drums – Part A – Product Number: 310472

50-gallon drums – Part B – Product Number: 310473

15-gallon drums – Part A – Product Number: 317329

15-gallon drums – Part B – Product Number: 317331

5-Gallon Jug – Part A – Product Number: 329722

5-Gallon Jug – Part B – Product Number: 329723

Dual Tank – Part A – Product Number: 336119

Dual Tank – Part B – Product Number: 336341

Dual Cartridge – Product Number: 322958

Shelf Life: 12 months (Part A and Part B)

Flexible FAST Accessories:

5-Gallon Jug – Static Mixing Tip (Patriot Jr., HULK, PaceCart): 331294

Dual Tank Nozzle Extension Tubes 14": 330881

Dual Tank Nozzle Tips: 341412

Dual Tank Gun Hoses 25': 341411

* Not compliant in all CA counties

Low-VOC UN-TACK™ Adhesive Remover and Cleaner



Used to clean spray guns and hoses applied by CAV-GRIP III Low-VOC Adhesive/Primer. Removes adhesives and primers from a variety of surfaces including single-ply membranes, accessories, metal, plastic, rubber, and glass. Low-VOC UN-TACK is VOC compliant in all 50 states.

Coverage Rate: 250 – 300 square feet per cylinder

Packaging: #8 Aerosol Cylinder

Product Number: 330793

Splice Cement



Designed for splicing cured-to-cured EPDM membranes and non-PS flashings, this high strength, solvent-based contact cement allows quick bonding of flashing, sheeting, and cured rubber seams. Formulated for application

with a ½" medium nap roller and/or a ½"-thick paint brush, the versatile tack time allows large areas to be coated and adhered at one time.

Coverage Rate: 100 square feet per gallon. *This product is for use on non-warranted projects only.*

Packaging: (6) 1-gallon cans – Black and White

Product Number:

302342 – Black

302147 – White

Shelf Life:

12 months – Black

9 months – White

CAV-GRIP® III Low-VOC Adhesive/Primer



Carlisle's CAV-GRIP III Low-VOC Adhesive/Primer can be used for a variety of applications: adhering Sure-Weld® TPO and Sure-Seal, Sure-Tough and Sure-White EPDM membranes in the field of the roof and vertical walls, and adhering FleeceBACK® to vertical walls. It can also be used as a primer for VapAir Seal™ 725TR and priming unexposed asphalt prior to applying Flexible FAST Adhesive for insulation attachment.

Coverage Rate: See Product Data Sheet.

Packaging:

40 aerosol cylinder – Product Number: 329902

85 aerosol cylinder – Product Number: 332659

Shelf Life: 12 months unopened container

Spray Patterns:

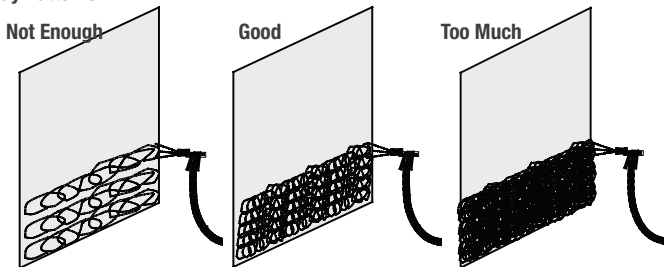

CAV-GRIP III Accessories



Spray Gun

Carlisle's CAV-GRIP Spray Gun is an industrial grade spray gun for use with CAV-GRIP III Low-VOC Adhesive/Primer. The ergonomic handle makes it easy to apply bonding adhesive to vertical surfaces.

Installation

1. Use the adjustment wheel to close the valve until ready to use.
2. Ensure all fittings are tight and leak free.
3. Position the gun tip 12" to 14" from the surface. This allows for maximum pattern width.
4. Hold gun at a 90 degree angle to the surface by locking your wrist. Try not to move your wrist as that will cause an irregular spray pattern.
5. When you are done spraying, turn the adjustment wheel to the closed position. This will lock the gun.
6. When you want to resume spraying, turn the adjustment wheel to the open position. No cleaning should be needed if the hose and gun remain pressurized.
7. To clean the CAV-GRIP spray gun, turn the cylinder off at the valve. Ensure there is no adhesive left in the hose and gun. Hook the hose up to a cylinder of Low-VOC UN-TACK™ to clean the system. Turn cylinder off and drain Low-VOC UN-TACK from the hose.
8. Use an adjustable wrench to remove and replace spray tips as necessary.

Packaging:

Adjustable Spray Gun – Product Number: 307490
Spray Gun with Extension – Product Number: 330912
Replacement Tips – Product Number: 332774



Hose & Splitter

The CAV-GRIP Low-VOC Adhesive/Primer Hose should be used in conjunction with CAV-GRIP III and a CAV-GRIP Spray Gun. The CAV-GRIP Hose is available in 6', 12' and 18' lengths.

Installation

1. Ensure all fittings are tight and leak free
2. No cleaning should be needed if the hose and gun remain pressurized.
3. To clean the CAV-GRIP spray gun, turn the cylinder off at the valve. Ensure there is no adhesive left in the hose and gun. Hook the hose up to a cylinder of Low-VOC UN-TACK to clean the system. Turn cylinder off and drain Low-VOC UN-TACK from the hose.
4. Use an adjustable wrench to attach the splitter to the CAV-GRIP cylinder.
5. Attach hoses to both ends of the splitter using an adjustable wrench.

Packaging:

6' Hose – Product Number: 304302
12' Hose – Product Number: 304303
18' Hose – Product Number: 304304
Hose Splitter – Product Number: 332680

Dual-Tip Spray Applicator



Carlisle's Dual-Tip Spray Applicator, specially designed for use with CAV-GRIP III, reduces application time by spraying two streams

adhesive with a single CAV-GRIP Spray Gun and Hose.

Product Number: 348903

CAV-PRIME Canisters



CAV-PRIME Sure-Seal EPDM HP-250 Primer

CAV-PRIME Sure-Seal EPDM HP-250 Primer is Carlisle's HP-250 Primer packaged in a pressurized cylinder for spray application. HP-250 Primer is a solvent-based product designed for one-step cleaning and priming of EPDM surfaces prior to the application of SecurTAPE™, Factory-Applied Tape (FAT), and all other pressure-sensitive (PS) products. CAV-PRIME primers are applied using a self-contained spray system coupled with a spray gun with extension wand and applicator attachment kit. CAV-PRIME spray guns, hoses, and applicator attachment kits are sold separately.

Coverage Rate: Approximately 1,320 ft²/cylinder (402 m²) can be expected when used with Pre-Kleened membrane or in seam areas that have been cleaned prior to application. Do not use with standard (dusted) membrane without cleaning.

Packaging: # 20 small cylinder – Product # 341445



CAV-PRIME Low-VOC EPDM and TPO Primer

CAV-PRIME Low-VOC EPDM & TPO Primer is Carlisle's Low-VOC membrane primer packaged in a pressurized cylinder for spray application. Low-VOC Primer is a solvent-based product designed for one-step priming of EPDM or TPO surfaces prior to the application of Factory-Applied Tape, Coverstrip, SecurTAPE and all other pressure-sensitive (PS) products. This product is designed to comply with VOC regulations. CAV-PRIME is applied via a self-contained spray system coupled with a spray gun with extension wand and applicator attachment kit. CAV-PRIME spray guns, hoses, and applicator attachment kits are each sold separately.

Coverage Rate: Approximately 1,760 ft²/cylinder (163.5 m²) can be expected on Kleen EPDM and TPO membrane. Do not use with standard (dusted) EPDM membrane without cleaning.

Packaging: # 20 small cylinder – Product # 341449



CAV-PRIME Low-VOC Hose & Gun Cleaner

Carlisle's CAV-PRIME Low-VOC Hose & Gun Cleaner is designed to clean the spray guns and hoses used to apply CAV-PRIME primers. It can also be used to remove primer from various surfaces including single-ply membranes, accessories, and metal. CAV-PRIME Low-VOC Hose & Gun Cleaner is VOC compliant in all 50 states.

Coverage Rate: 250 – 300 ft² per cylinder

Packaging: # 16 mini cylinder – Product # 341407

CAV-PRIME Accessories



CAV-PRIME Applicator Attachment

Overview

Carlisle's CAV-PRIME Applicator Attachment consists of specially designed clamps and baton which allow a roller to be attached to a 2' or 3' spray gun extension so primer can be sprayed and rolled in one step. The clamps are made from durable but light milled aluminum and feature thumb screws for easy adjustment. The baton features male threads at one end and fits most commonly available threaded roller handles

Installation

1. Separate the two aluminum clamps by removing the thumb screws and lay the clamp halves that contain the internal threads flat, with the cradles facing up.
2. Place the 10" threaded baton onto the larger cradles milled into the clamp halves and the 2'- or 3'-long extension gun into the small cradles of the clamp halves.
3. Place the other half of the aluminum clamps over the pole and gun extension, lining up the screw holes. Thread the thumb screws into the clamps, tightening them just enough so final adjustments can still be made.
4. Thread a 4"-wide roller handle onto the baton and adjust the baton/roller so that the spray tip is just above the roller and the roller can comfortably be pushed using the handle of the gun. Fully tighten the thumb screws to prevent the baton/roller from spinning/sliding during application.

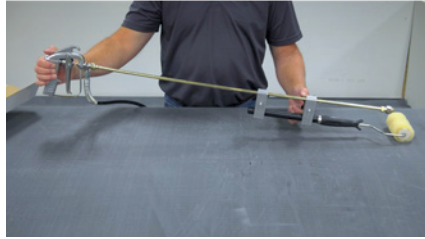

CAV-PRIME Spray Gun

Overview

Carlisle's CAV-PRIME Spray Gun is an industrial grade spray gun with a 3' extension nozzle for use with CAV-PRIME primers. The ergonomic handle makes it easy to spray and roll primer when used in conjunction with the CAV-PRIME Applicator Attachment Kit. The CAV-PRIME Spray Gun's 3' extension is made from durable and rigid stainless steel for less flex when rolling primer.

Note: Avoid cross contamination of CAV-PRIME and CAV-GRIP III/CAV-GRIP PVC Adhesive in spray gun/equipment. **NEVER USE LOW-VOC UN-TACK to clean CAV-PRIME Spray Guns or tips** as it will cause primer to gel inside the hose/gun.

Installation

1. Use the trigger adjustment wheel to lock the trigger closed until ready to use.
2. Ensure all fittings are tight and leak free.
3. Install the CAV-PRIME Applicator Attachment and roller.
4. Use the adjustment wheel to adjust trigger depth and spray velocity. Apply and roll primer per Carlisle specifications and details.
5. When you are done spraying, turn the adjustment wheel to the closed position. This will lock the gun.
6. When you want to resume spraying, turn the adjustment wheel to the open position. No cleaning should be needed if the hose and gun remain pressurized.
7. To clean the CAV-PRIME gun, hose, or tip, turn the cylinder off at the valve. Ensure there is no adhesive left in the hose and gun*. Hook the hose up to a cylinder of CAV-PRIME Low-VOC Hose & Gun Cleaner to clean the system. Turn cylinder off and drain Hose & Gun Cleaner from the hose.
8. Use an adjustable wrench to remove and replace spray tips as necessary.

* CAV-PRIME guns and hoses can be utilized multiple times if maintained properly

Low-VOC Primer



Designed for one-step cleaning and priming of EPDM surfaces prior to the application of pressure-sensitive products. It is a Low-VOC product that is ideal for use where environmental issues are a concern.

Coverage Rate: As high as 600 square feet per gallon with Kleen EPDM membrane. Approx. 250 square feet per gallon with dusted EPDM membrane.

Packaging:

1-gallon pail – Product Number: 329160

3-gallon pail – Product Number: 332714

Shelf Life: 12 months

HP-250 EPDM Primer



A solvent-based product designed for cleaning and priming EPDM membranes prior to the application of pressure-sensitive products. Coverage Rate: As high as 450 square feet per gallon with Kleen EPDM membrane. Approx. 250 square feet per gallon with dusted EPDM membrane

Packaging:

(6) 1-gallon cans – Product Number: 302070

(1) 3-gallon pail – Product Number: 332683

Shelf Life: 12 months

Sure-Seal and Sure-White Lap Sealants



Gun-consistency material used to seal the exposed cut edge of Sure-Tough membranes, and the edges of Elastoform Flashing.

Coverage Rate: 22' per tube using a 3/16" bead

Packaging: 25 Tubes/carton

Product Number:

302174 – Black

302172 – White

Shelf Life: 12 months

Two-Part Pourable Sealer



A two-component, solvent-free, polyurethane-based product compatible with Carlisle's Sure-Seal and Sure-White membranes.

Designed to provide a flexible, durable and long-

lasting seal around hard-to-flash penetrations. Can also be used to provide a permanent tie-in between Sure-Seal membranes and a built-up roof surface, and for attaching lightning rod bases and ground cable clips to the membrane surface.

Coverage Rate: 231 cubic inches of volume per properly mixed gallon.

Packaging:

Part A – (2) 1-gallon pails/ctn.

Part B – (2) 1-pint cans/ctn.

Product Number: 302084

Shelf Life: 12 months unopened container

One-Part Pourable Sealer



A single-component, moisture-curing, elastomeric polyether sealant that is compatible with Carlisle's EPDM membranes. Designed to provide a flexible, durable and long-

lasting seal around hard-to-flash penetrations. The sealant's consistency allows for quick pocket filling without mixing. Unused sealant is usable for up to 30 days if pouch is resealed with original cap.

Coverage Rate: 122 cubic inches of volume per 1/2-gallon pouch.

Packaging: (4) 1/2-gallon pouches per bucket

Product Number:

307647 – Black

307603 – White

Shelf Life: 12 months unopened container

Universal Single-Ply Sealant



A 100%-solids, solvent-free, one-part, polyether sealant that provides a weathertight seal to a variety of building substrates.

Coverage Rate: 25' per tube or 600' per carton using a 1/4" bead.

Packaging: 24 Tubes/carton

Product Number:

310131

349227 – Gray

Shelf Life: 12 months

unopened container

(@ <90°F)

Water Cut-Off Mastic



A one-component, low-viscosity, self-wetting, butyl-blend mastic used in conjunction with roofing and waterproofing systems. It is used as a sealing agent between various membranes and substrates for compression-type terminations.

Coverage Rate: 10' per tube, using a 7/16" bead.

Packaging: 25 Tubes/carton

Product Number: 319621

Shelf Life: 12 months

unopened container

EPDM Accessories

Pressure-Sensitive SecurTAPE

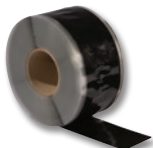

Fully cured synthetic rubber product used for splicing cured EPDM membrane in ballasted, adhered and mechanically fastened roofing systems.

Sizes Available:

3" x 100' – Product Number: 300465 – Black

3" x 100' – Product Number: 303260 – White

6" x 100' – Product Number: 302952 – Black

6" x 100' – Product Number: 317501 – White

Quantity Per Box: 4 rolls (3"), 2 rolls (6")

Pressure-Sensitive Cured Cover Strip



Cured EPDM membrane laminated to a synthetic rubber adhesive makes this product the optimal solution to overlay seam fastening plates, strip in seams and metal edgings, or make roof repairs.

Sizes Available:

6" x 100' – Product Number: 308701 – Black

6" x 100' – Product Number: 308910 – White

9" x 100' – Product Number: 308839 – Black

9" x 100' – Product Number: 309121 – White

12" x 50' – Product Number: 317598 – Black

12" x 50' – Product Number: 317596 – White

Quantity Per Box: 2 rolls (6"), 1 roll (9" and 12")

Pressure-Sensitive Curb Flashing



Cured EPDM membrane pre-cut to 20" wide with 6" PS SecurTAPE already applied. This product provides an efficient way to flash curbs and short walls.

Sizes Available:

20" x 50' – Product Number: 308705 – Black

Quantity Per Box: 1 roll

Pressure-Sensitive Elastoflash®

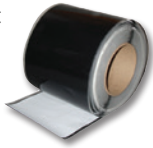

Uncured EPDM laminated to synthetic rubber adhesive. Pressure-Sensitive Elastoflash can be used to flash corners, pipes, and other penetrations.

Sizes Available:

6" x 100' – Product Number: 310433 – Black

6" x 100' – Product Number: 310434 – White

9" x 50' – Product Number: 303162 – Black

9" x 50' – Product Number: 309950 – White

12" x 50' – Product Number: 305723 – Black

12" x 50' – Product Number: 309951 – White

12" x 50' – Product Number: 348768 – Gray

Quantity Per Box: 2 rolls (6"), 1 roll (9" and 12")

Pressure-Sensitive Overlayment Strip



Semi-cured EPDM laminated to a synthetic rubber adhesive. It is designed for stripping in drip edges, all types of metal edging and seams, and all fastening plates.

Sizes Available:

6" x 100' – Product Number: 302319 – Black

9" x 100' – Product Number: 302281 – Black

12" x 50' – Product Number: 317600 – Black

Quantity Per Box: 2 rolls (6"), 1 roll (9"), 1 roll (12")

Pressure-Sensitive Walkway Pads



Cured EPDM with a synthetic rubber adhesive. Pressure-Sensitive Walkway Pads are designed to protect the Carlisle EPDM membrane in areas exposed to repetitive foot traffic.

Sizes Available:

30" x 30" – Product Number: 300829 – Black

30" x 30" – Product Number: 309589 – White

Quantity Per Box: 50

20" Pressure-Sensitive Cured Flashing



20" Pressure-Sensitive (PS) Cured Flashing is pre-cut with factory-applied SecurTAPE and is the most efficient, labor-saving way to flash a curb on EPDM. Production time on projects with numerous curbs or wall flashings can be reduced with this productivity-boosting accessory.

Sizes Available:

20" x 50' – Product Number: 329385 – Black

20" x 50' – Product Number: 330913 – White

Quantity Per Box: 1 roll

Pressure-Sensitive RUSS

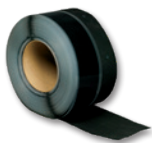

Reinforced Universal Securement Strip (RUSS) combines reinforced EPDM with 3"-wide Pressure-Sensitive SecurTAPE for additional membrane securement at the perimeter and penetrations.

Sizes Available:

6" RUSS – Product Number: 300490 – Black

6" RUSS – Product Number: 309268 – White

Use with all EPDM Systems

9" RUSS – Product Number: 300489

Use with Mechanically Fastened EPDM Systems

Quantity Per Box: 2 rolls (6"), 1 roll (9")

Pressure-Sensitive Pourable Sealer Pockets



Uncured EPDM laminated to a synthetic rubber adhesive and a 2" support strip pre-applied to the flashing. Sizes can be combined to form larger pockets when required.

Sizes Available:

4" diameter – Product Number: 300208 – Black

6" diameter – Product Number: 300209 – Black

6" diameter – Product Number: 316243 – White

8" diameter – Product Number: 300210 – Black

8" diameter – Product Number: 332890 – White

Quantity Per Box: 12

Pressure-Sensitive T-Joint Covers



Uncured EPDM laminated to a synthetic rubber adhesive. Used to seal field splice intersections and horizontal-to-vertical transitions of field splices. 12" x 12" T-Joint Covers are available for 30-Year Warranty Systems.

Sizes Available:

6" x 6" – Product Number: 303100 – Black

6" x 6" – Product Number: 332871 – White

12" x 12" – Product Number: 305089 – Black

Quantity Per Box: 20

Pressure-Sensitive Inside/Outside Corners



Uncured EPDM laminated to a synthetic rubber adhesive. The pre-cut corners greatly reduce installation time and can be used for inside and outside corner installations.

Sizes Available:

7" x 9" – Product Number: 300199 – Black

7" x 9" – Product Number: 310310 – White*

Quantity Per Box: 20

*White can also be used as a T-Joint Cover

Pressure-Sensitive Pipe Seals



Cured EPDM with a synthetic rubber adhesive. PS Pipe Seals increase the speed and ease of installation.

Sizes Available:

½" – 3" – Product Number: 300204 – Black

1" – 6" – Product Number: 309750 – Black

1" – 6" – Product Number: 316593 – White

Quantity Per Box: 10

Pipe Supports

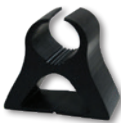

An extruded EPDM product used to support steel pipe, electrical conduit, PVC pipe, and copper tubing on EPDM roofing systems.

Sizes Available:

Mini: ½" - 1½" – Product Number: 309403

Small: ¾" - 2" – Product Number: 309402

Large: 2½" - 5" – Product Number: 309404

Quantity Per Box: 20 (Mini and Small), 10 (Large)

SECTION 3: TOOLS & EQUIPMENT

1. **Roof Cleaning Equipment**
 - a. Utilize a broom or a leaf blower to clean dust and debris from substrate prior to installation of adhesives and membranes
2. **Caulk Gun**
 - a. Required for proper application of Lap Sealant and other miscellaneous sealants
3. **Plastic Lap Sealant Tool**
 - a. Included with Sure-Seal Black and Sure-White Pressure-Sensitive Elastofom Flashing cartons. Required for feathering sealant after application with caulk gun
4. **Nap Roller**
 - a. 4" and 9"-wide medium ($\frac{3}{8}$ " nap roller and roller cage
 - b. For installing roller applied adhesives and splice primers
5. **HP Splice Wipes**
 - a. Use in conjunction with Splice Cleaners or Primer to clean and prime membrane prior to installing lap splices and pressure sensitive accessories
6. **Shop broom**
 - a. Required when installing all adhered roof systems ensuring adequate adhesion between membrane and substrate
7. **150 lb. Segmented Weighted Roller**
 - a. Required after brooming membrane on adhered systems utilizing self-adhered sheets, CAV-GRIP III Adhesive/Primer, Flexible FAST Adhesive, or RapidLock EPDM membrane
8. **2" Seam Roller**
 - a. Required when installing seams and all pressure-sensitive flashing products
9. **Temperature gun and heated blankets**
 - a. For warming adhesives to the proper temperature prior to application
10. **Other useful tools and accessories**
 - a. Commercial grade generators and OSHA compliant power cords
 - b. OSHA compliant fall guards such as perimeter railing systems and harnesses
 - c. Scissors for cutting membrane and various pressure-sensitive flashings
 - d. Heat gun for warming pressure-sensitive accessories during cold weather flashing installations
 - e. Adjustable wrench for replacing the brass tips on CAV-GRIP III spray guns
 - f. Tape measure
 - g. Chalk line
 - h. Utility knife

SECTION 4: COMMON INSTALLATION ISSUES

Splice Problems and Splice Repairs

A. Cautions

1. Due to solvent flash-off, condensation may form on freshly applied primer when the ambient temperature is near the dew point. If condensation develops, the application of primer and SecurTAPE must be discontinued since proper adhesion will not be achieved. Allow the primer surface to dry and apply a thin freshener coat of primer to the previously coated surface and apply SecurTAPE when conditions allow. Do not stir Low-VOC Primer.

B. Splice Repairs

1. General

- a. Prior to initiating repairs, the membrane must be cleaned to remove field dirt and other contaminants. Using a scrub brush, scrub the splice areas with warm water and a low-sudsing soap (Spic and Span, Tide, Lestoil). Rinse with clean water and allow to dry prior to applying Weathered Membrane Cleaner or Carlisle EPDM Primer as required.
- b. Sure-Seal Weathered Membrane Cleaner can be used to prepare membrane exposed to the weather prior to applying Carlisle EPDM Primer. Saturate a clean HP Splice Wipe or natural fiber rag (cotton) with Weathered Membrane Cleaner and scrub the area in a circular motion. Continue cleaning until the surface is a consistent matte black color without streaking.

2. Repairs of Cuts and Tears (Surface Splice)

Repairs to cuts and tears in the membrane must be accomplished by splicing a membrane section over the affected area.

- a. Select a repair membrane, which is the same material as that to be repaired.
- b. Extend the repair membrane section at least 3" in every direction from the cut or tear. Round the corners of the repair membrane prior to splicing. Clean the membrane to remove field dirt and other contaminants as outlined above.
- c. Apply Carlisle EPDM Primer to the splice areas. Install Pressure-Sensitive Cured Cover Strip or Cured Membrane and SecurTAPE and then hand roll the splice areas. Apply T-Joint Covers at splice intersections. Lap Sealant is applied at flashing and tape overlaps in accordance with standard procedures.

3. Repair of Improperly Installed Tape Splices

- a. Improperly installed tape splices include, but are not limited to, fishmouths at field splices, lack of or improper use of Primer, condensation formation on Primer or incorrect tape placement, etc.
- b. If fishmouths are present in the field splice, the fishmouth must be cut by removing the top layer of membrane prior to overlaying the splice. The flashing overlay must be supported by the bottom layer of cured membrane.
- c. Clean the splice area with Weathered Membrane Cleaner. Apply EPDM Primer on both sides extending past the width of the new flashing overlay to be installed.
- d. Overlay the defective splice area with a minimum 6" wide Sure-Seal Pressure-Sensitive Uncured Elastoform, Cover Strip or Overlayment Strip centered over the edge of the splice. If using Pressure-Sensitive Elastoform, apply Lap Sealant around the outer edge and feather accordingly.

SECTION 5: STAGING & STORAGE BEST PRACTICES

General

- Perimeter warning lines and safety equipment must be in place per OSHA requirements prior to beginning any of the following roof activity.
- Before staging material, an assessment of the roof should be conducted to determine work flow, staging areas, weak spots, structural layout and placement of rolls and insulation.

Insulation

- Insulation and underlayment must be stored so it is kept dry and protected from the elements. Store bundles flat and upright with the bottom of the bundles elevated (2" or more) above a finished surface.
- Slit the insulation bundle packaging vertically down the center of the two short sides to prevent moisture accumulation within the package. Completely cover the bundle with a waterproof tarp and secure to prevent wind damage and/or displacement.

Adhesives/Primers

- Keep these products between 60°F – 80°F (15°C – 26°C) for best results and ease of application.
- Jobsite storage more than 90°F (32°C) may affect product shelf life. Prolonged exposure to below-freezing temperatures will cause the adhesive to thicken and eventually solidify in the can. Should the Low-VOC Bonding Adhesive be stored below freezing, restore to room temperature for a minimum of 24 hours prior to use; the adhesive will perform as intended once it is returned to a liquid state. When temperatures are expected to be consistently below 40°F (4°C), a heated enclosure or hot box is recommended for jobsite storage. Keep the adhesive between 60°F – 80°F (15°C – 26°C) for ease of application.
- Products are **EXTREMELY FLAMMABLE**. It contains solvents that are dangerous fire and explosion hazards when exposed to heat, flame or sparks. Do not smoke while applying. Do not use in a confined or unventilated area. Vapors are heavier than air and may travel along ground or may be moved by ventilation and ignited by pilot lights, other flames, sparks, heaters, smoking, electrical motors, static discharge or other ignition sources at locations distant from material handling point and flashback. Use only non-sparking tools. All containers should be grounded when material is transferred from one container to another. A red caution label is required when shipping. A fire extinguisher should be available. In case of fire, use water spray, foam, dry chemical or carbon dioxide. Do not use a solid stream of water, because it can scatter and spread the fire.
- These materials are sensitive to atmospheric moisture; heat will accelerate the effect of moisture. Opened containers of bonding adhesive should be used within 48 hours. Adhesive will begin to thicken after this point, making it difficult, and eventually impossible, to control adhesive thickness.

CAV-GRIP III Low-VOC Adhesive/Primer

- Store cylinders in protected, conditioned space with temperature maintained above 70°F (21°C). Do not store cylinders in areas where temperatures reach 110°F (43°C) or higher. Contents are flammable. Store in accordance with local, state, and federal regulations.

Application Tips – Field Membrane:

- Allow EPDM membranes to relax for 30 minutes prior to applying adhesive.
- Achieve the proper coverage rate of 1,000 square feet per 40# cylinder using the extension wand with an approximate 1-2" (2.5-5cm) overlap of adhesive at each pass.
- Feather the spray gun at the end of each pass to avoid heavy areas which can cause blisters due to trapped solvents. Holding the gun too close to the surface can result in heavy application. Break the skin with a roller in heavy spots allowing solvents below the skin to flash-off.
- Allow adhesive in overlaps or heavy areas to flash-off until it does not transfer to your finger when touched or pushed. Use the "tack and push test" to ensure solvents have flashed-off and adhesive is tacky prior to installing the membrane. CAV-GRIP III has a generous open time.

- Flash off takes longer in cooler, cold or cloudy conditions, in shaded areas, and in areas with heavy adhesive coverage.
- Rapid solvent flash-off can lower the surface temperature below the dew point causing moisture to form on the adhesive. Slide your hand across the flashed-off adhesive on the insulation or cover board to ensure moisture has evaporated and the adhesive surface is dry and tacky prior to installing the membrane.
- Broom and roll the membrane with a segmented weighted roller. Pressure is required for a proper bond. Segmented 150-pound rollers are available through Rooftop Equipment at 800-222-6454.

Application Tips - Wall Flashings:

- Same as note above except for a 50% overlap is required at each pass and the extension wand is not recommended for adhesive application on walls.
- Broom walls and roll with a silicone hand roller. Wider extendable Floor Rollers are available at most home improvement stores.

Membrane and Flashing

- Store EPDM membrane in the original undisturbed plastic wrap and cover with light colored, breathable tarpaulins. EPDM flashing should also be stored in the original packaging in the same manner.
- SAT EPDM membrane must be stored in the original undisturbed plastic wrap in a cool, shaded area and cover with light-colored, breathable, waterproof tarpaulins. Minimum temperature requirements for the various SAT EPDM membranes are based on substrate and fastening method as outlined below:

Sure-Seal SAT EPDM

- 40°F (4°C) ambient and 50°F (10°C) sheet temperature after relaxation for all approved substrates and fastening methods.
- 32°F (0°C) ambient and 40°F (4°C) sheet temperature after relaxation for DensDeck Prime and SECUROCK fastened with urethane adhesive.

Sure-Tough SAT EPDM

- 40° F (4°C) ambient and 50° F (10°C) sheet temperature after relaxation for all approved substrates and fastening methods.
- 32°F (0°C) ambient and 40°F (4°C) sheet temperature after relaxation for Insulbase, DensDeck Prime and SECUROCK fastened with urethane adhesive.

Sure-White SAT EPDM

- May be installed when the ambient temperature is 32°F (0°C) and is approved for application to DensDeck Prime, SECUROCK, SecurShield HD, SecurShield HD Plus, and clean concrete.
- When positioning the rolls on the roof pay attention to the “unroll” labels found on each individual roll to reduce the need for repositioning.

Pressure-Sensitive Products

- All pressure-sensitive EPDM accessories must not be exposed to prolonged jobsite storage temperatures more than 90°F (32°C). In warm, sunny weather, keep all pressure-sensitive EPDM accessory rolls in their box or in a shaded area until ready to use. Storage and use at temperatures below 40°F (4°C) will result in a loss of adhesive tack, and in extreme cases will result in an inadequate bond to the substrate.

EPDM Accessories

- Thermoset accessories to include molded and prefabricated products should be stored in a cool, shaded area and cover with light colored, breathable, waterproof tarpaulins.
- Liqueal Liquid Flashing products are to be stored in a cool, dry location between 35°F – 80°F (1°C – 26°C). Do not store in direct sunlight. Approximate shelf life is 12 months with proper storage. Best practice is to store material at 65°F – 70°F (18°C – 21°C) for 24 hours before use. Do not install if ambient temperature is below 40°F (4°C) or above 90°F (32°C).

SECTION 6: EXECUTION/INSTALLATION PROCEDURE

Sure-Seal™ EPDM
Roofing Systems

Sure-Tough™ EPDM
Roofing Systems

Sure-Seal/Sure-White/Sure-Tough EPDM Roofing Systems **Adhered, Ballasted and Mechanically Fastened**

July 2023

The information contained in this generic specification represents a part of Carlisle's requirements for obtaining a roofing systems warranty. Construction materials and practices, building siting and operation, climatic conditions, and other site-specific factors will have an impact on the performance of the roofing system. Carlisle recommends that the building owner retain a design professional to determine appropriate design measures to be taken in order to address these factors.

This section is to serve as criteria for Specifiers and Authorized Applicators regarding the design and installation of Carlisle's Design "A" Adhered, Design "B" Ballasted and Reinforced Mechanically Fastened EPDM Membrane Roofing Systems. Additional information essential for the design and installation of the roof system mentioned herein are also included in the Design Reference Section and also listed in the form of a Specification Supplement at the end of the Technical Manual. Specifiers and Authorized Applicators are advised to reference all applicable sections.

Various Warranty Tables have been included in Paragraph 1.05 citing various requirements by which specific warranty coverage can be obtained. Appropriate Warranty Table should be referenced to ensure proper warranty coverage.

PART I – GENERAL

1.01 Description

- A. **The Design "A" Adhered Roofing System incorporates Sure-Seal (black) 60 or 90- mil thick non-reinforced or Sure-White (white-on-black) 60 or 90-mil thick non-reinforced or Sure-White (white-on-black) 60-mil thick reinforced or 45, 60 or 75-mil Sure-Tough reinforced EPDM membrane.** An acceptable insulation is mechanically fastened to the roof deck or adhered with Carlisle supplied urethane-based insulation adhesive or hot asphalt and the EPDM membrane is fully adhered to the insulation with Carlisle EPDM Bonding Adhesive (Sure-Seal Bonding Adhesive, Low-VOC Bonding Adhesive, Water Based Bonding Adhesive and CAV-GRIP III Bonding Adhesive). Adjoining sheets of EPDM membrane are spliced together using 3" or 6" wide SecurTAPE and Primer OR Factory-Applied TAPE (FAT) and Primer. There are no maximum slope restrictions for the application of this roofing system.

NOTE: When non-reinforced EPDM membrane is used, Carlisle recommends a minimum of 60-mil thick material. Sure-Seal FR 45-mil non-reinforced EPDM may be utilized when specified or required by the owner or owner's representative.

Water based adhesive may be used for projects with 20 year maximum warranty and wind speed coverage up to 72 mph.

- B. **The Design "B" Loose Laid Ballasted Roofing System incorporates minimum 45-mil thick Sure-Seal (black) non-reinforced or minimum 60-mil Sure-Tough reinforced EPDM membrane.** Both the EPDM membrane and an acceptable membrane underlayment or insulation are loose laid over the substrate and held in place with a minimum of 10 pounds of ballast per square foot depending upon wind load requirements. Adjoining sheets of EPDM membrane are spliced together using 3" or 6" wide SecurTAPE and Primer OR Factory-Applied TAPE (FAT) and Primer. The maximum roof slope for this roofing system is 2" to one horizontal foot.

- C. **The Mechanically Fastened Roofing System** incorporates **45, 60 or 75-mil Sure-Tough or 60-mil Sure-White (white-on-black) reinforced EPDM membrane**. An acceptable insulation is mechanically fastened to the roof deck and, depending on project criteria; the reinforced membrane is mechanically fastened with the appropriate Carlisle Fastener and 2" or 2-3/4" diameter Fastening Plates (Polymer Seam Plates required over steel deck) or Fastening Bars at 6" minimum to 12" maximum along the center of the membrane splice.

Adjoining sheets of EPDM membrane are spliced together using 6" Factory-Applied TAPE (FAT) and Primer OR 6" SecurTAPE and Primer. Field membrane sheets are either 5', 6.5', 8' or 10' wide depending upon wind load requirements, building height and type of roof deck. At the roof perimeter, a heavier fastening density is required utilizing 5', 6.5' wide sheets or 9" wide Pressure-Sensitive RUSS (Reinforced Universal Securement Strip). The maximum roof slope for this roofing system is 18" in one horizontal foot.

This roofing system can also be specified over an existing standing seam, flat seam or corrugated metal roof with the membrane secured to the structural purlins. Refer to the Metal Retrofit System Specification and Details.

NOTE: The selection of various components (i.e. insulation, underlayment, membrane thickness, etc.) may vary depending on desired Warranty coverage. Refer to appropriate Warranty Tables listed in Paragraph 1.05.

Assemblies with membrane fasteners 12" or longer must be submitted for Carlisle's review to ensure adequate securement due to the possibility of increased dynamic fastener movement. Such assemblies when accepted may require the use of additional insulation fasteners and the use of 1/2" SecurShield HD Recover Board.

1.02 General Design Considerations

- A. Projects where wind speed coverage greater than 55 mph is specified or those with a 20-year or longer Total System Warranty will require additional enhancements beyond those outlined in this section. Prior to installation, refer to Warranty Tables in Paragraph 1.05.
- B. Petroleum based products; certain chemicals and waste products (i.e., grease, oil, animal fats, etc.) are not compatible with these roofing systems. Carlisle should be contacted for verification of compatibility and recommendations concerning an acceptable roofing assembly.
- C. It is the responsibility of the specifier to review local, state and regional codes to determine their impact on the specified Carlisle Roofing System.
- D. It is the responsibility of the building owner or his/her designated representative to verify structural load limitation. In addition, a core cut may be taken to verify weight of existing components when the roofing system is to be specified on an existing facility.
- E. Coordination between various trades is essential to avoid unnecessary rooftop traffic over completed sections of the roof and to prevent subsequent damage to the membrane roofing system.
- F. Concentrated loads from rooftop equipment may cause deformation of insulation/underlayment and possible damage to the membrane if proper protection is not provided. A protection course or sleepers must be specified.
- G. Drainage
 - 1. Drainage must be evaluated by the Specifier in accordance with all applicable codes. Slopes may be provided by tapering the structure or through the use of tapered insulation; a sufficient number of roof drains should also be specified and properly located to allow for positive drainage. Significant ponding that could remain after 48 hours should be eliminated with the addition of auxiliary drains in low areas where ponding is anticipated. Carlisle specifically disclaims responsibility for the design and selection of an adequate drainage system and drain accessories. Selection must be made by the building owner or the owner's design professional.

2. Small incidental areas of ponded water will not impact the performance of this roofing system; however in accordance with industry standards, the roofing assembly **should be designed to prevent ponding** of water on the roof for prolonged periods (longer than 48 hours). Good roofing practice dictates proper drainage to prevent possible excessive live loads and, in the event of a roof leak, to minimize potential interior damage to the roofing assembly and to the interior of the building.
 3. **Tapered edge strips, crickets or saddles** are recommended where periodic ponding of water may occur. When the slope of the taper exceeds 2" to one horizontal foot additional membrane securement at the base of the tapered edge strip, cricket or saddle will be required.
 4. On **Sure-White Roofing Systems**, a slope greater than 1/8" per horizontal foot is recommended to serve the long-term aesthetics.
- H. On new construction projects, especially in cold climate regions, moisture generated due to the construction process could adversely impact various components within the roofing assembly if not addressed. Refer to **Design Reference DR-01-21" Construction Generated Moisture"**.
- I. On structural concrete decks, when a vapor retarder is not used, gaps in the deck along the perimeter and around penetrations must be sealed along with vertical joints between tilt-up panels, if present, to prevent infiltration of hot humid air and possible moisture contamination resulting from condensation. This is specifically important when polyurethane adhesive is used to attach the roof insulation.
- NOTE:** If left unaddressed, collected moisture could weaken insulation boards and facers resulting in a blow-off or increase the probability of mold growth.
- J. **Retrofit - Recover Projects** (when the existing roofing material is left in place)
1. The removal of existing wet insulation and membrane must be specified. The Specifier shall select an appropriate and compatible material as filler for voids created by removal of old insulation or membrane.
 2. A core cut should be taken to verify weight of existing components when the roofing system is to be specified over an existing roofing assembly.
 3. Entrapment of water between the old and new membrane can damage and deteriorate new insulation/underlayment between the two membranes. If a vapor retarder or air barrier is not specified, Carlisle recommends the existing membrane be perforated to avoid potential moisture accumulation and to allow the detection of moisture to enable the building owner to take corrective action. This can be accomplished by drilling approximately 3/4" diameter holes every 100 square feet in the existing built-up roof or single-ply membrane (excluding PVC membrane).
 4. Existing PVC membrane must be totally removed, or the existing membrane must be cut into maximum 10' by 10' sections. All PVC flashings at the perimeter, roof drains and roof penetrations must be removed.
- K. **Optional Color Coating**
1. Sure-Seal X-Tenda Coat™ Coating is recommended for color coating the EPDM membrane and flashing when required by the Specifier. Available in white or gray.
- X-Tenda Coat Coating can also be specified as a "Restoration System" when applied to an existing Carlisle EPDM membrane system that may qualify for a 5 or 10-year Coating System Warranty. Refer to Carlisle's published Sure-Seal X-Tenda Coat Coating Specification for specific requirements.
- NOTE:** Carlisle may be contacted for other optional color coatings.

1.03 Quality Assurance

Building codes are above and beyond the intended purpose of this specification. The building **owner, owner's representative or Specifier** should verify local codes for applicable requirements and limitations. It is the responsibility of the specifier to review local, state and regional codes to determine their impact on the specified Carlisle Roofing System.

NOTE: For code approvals achieved with the Carlisle EPDM Roofing Systems, refer to the Carlisle EPDM Code Approval Guide, DORA (Directory of Roof Assemblies), Factory Mutual (FM) Approval Guide or Underwriters Laboratories (UL) Fire Resistance or Roofing Materials and Systems Directories.

- A. When recovering or retrofitting an existing roof system, the addition of new insulation (type and thickness) may alter the fire performance characteristics of the assembly. Building owners or their designated representatives shall consult the local code enforcement agency to avoid potential code violation.
- B. Carlisle recommends the use of Carlisle supplied products for use with these Carlisle Roofing Systems. The performance or integrity of products by others, **when selected by the specifier and accepted as compatible by Carlisle**, is not the responsibility of Carlisle and is **disclaimed** by the Carlisle Warranty.
- C. The specified roofing system must be installed by a Carlisle Authorized Roofing Applicator in compliance with drawings and specifications as approved by Carlisle SynTec.
- D. Provide polyisocyanurate insulation that meets PIMA Quality Mark Certified LTRR value through third party verification meeting ASTM C 1289, Type II, Class 1, Grade 2.
- E. There must be no deviations made from Carlisle's specification or Carlisle's approved shop drawings without the **PRIOR WRITTEN APPROVAL** of Carlisle SynTec.
- F. After completion of the installation, upon request, an inspection shall be conducted by a Field Service Representative (FSR) of Carlisle SynTec to ascertain that the membrane roofing system has been installed according to Carlisle's published specifications and details applicable at the time of bid. This inspection is to determine whether a warranty shall be issued. It is not intended as a final inspection for the benefit of the owner.

1.04 Submittals

- A. To ensure compliance with Carlisle's minimum warranty requirements, the following projects should be forwarded to Carlisle for review prior to installation, preferably prior to bid.
 - 1. Air pressurized buildings, canopies, and buildings with large openings where the total wall openings exceed 10% of the total wall area on which the openings are located (such as airport hangars, warehouses and large maintenance facilities). Refer to Attachment IV at the end of this section for perimeter considerations, when a Mechanically Fastened System is specified.
 - 2. Cold storage buildings and freezer facilities.
 - 3. Design "A" Adhered Roofing Systems over 250' in height for projects with warranties up to 15 years.
 - 4. Design "A" Adhered Roofing Systems over 100' in height for projects with warranties greater than 15 years.
 - 5. Design "B" Ballasted Roofing System projects over 75' in height.
 - 6. Mechanically Fastened Roofing System projects over 100' in height.
 - 7. Projects where the EPDM is expected to come in direct contact with petroleum-based products, waste products (i.e., grease, oil, animal fats, etc) and other chemicals.
 - 8. Projects where hot asphalt is specified for insulation attachment.
 - 9. Mechanically Fastened projects specified with a fastener length exceeding 12 inches.
- B. Shop drawings must be submitted to Carlisle by the Carlisle Authorized Roofing Applicator along with a completely executed Notice of Award (Page 1 of Carlisle's Request for Warranty form) for approval. Approved shop drawings are required for inspection of the roof and on projects where on-site technical assistance is requested.

Shop drawings must include:

1. Outline of roof and size
2. Deck type (for multiple deck types)
3. Location and type of **all** penetrations
4. Perimeter and penetration details
5. Key plan (on multiple roof areas) with roof heights indicated
6. Sheet width and number of perimeter sheets for Reinforced Mechanically Fastened systems
7. Sure-Seal Fastener type, length and maximum spacing (for membrane securement) for Reinforced Mechanically Fastened systems.

- C. **Along with the project submittals** (shop drawing and Request for Warranty), the roofing contractor must include **pullout test** results when the results are below the requirements identified in the Table included in **Design Reference DR-06-19 “Withdrawal Resistance Criteria”**.
- D. Ballasted projects incorporating a **lightweight insulating concrete** substrate, a **certification letter is required** from the lightweight insulating concrete manufacturer for the following conditions:
1. The membrane is specified directly over **vermiculite or cellular** lightweight insulating concrete with a maximum compressive strength of 140 psi.
 2. The membrane is specified with HP Protective Mat as the membrane underlayment over **vermiculite or cellular** lightweight insulating concrete with a compressive strength between 140 – 175 psi.

The certification letter must reference the project name and location, accompany the project submittals (shop drawing and Request for Warranty) and contain the following information pertaining to the lightweight insulating concrete mix design:

1. Manufacturer’s brand name
 2. Maximum compressive strength
 3. Average wet density
 4. Average air dry density
- E. When field conditions necessitate modifications to the originally approved shop drawings, a copy of the shop drawing out–lining all modifications must be submitted to Carlisle for revision and approval prior to inspection and warranty issuance.
- F. **As-Built Projects** (roofing systems installed prior to project approval by Carlisle)

The Carlisle Authorized Applicator may supply Carlisle with an As-Built drawing for a project completed prior to Carlisle’s approval. The As-Built drawings:

1. Must conform to Carlisle’s most current published specifications and details applicable at the time of bid.
2. Must be submitted along with a completely executed Notice of Completion.
3. Must include the items identified in Paragraphs B, C and D above.

NOTE: As-Built projects are not recommended for those projects referenced in Paragraph A in order to ensure Carlisle warranty requirements have been met.

- G. **Notice of Completion** (Page 2 of the Carlisle Request for Warranty form)

After project completion, a Notice of Completion must be submitted to Carlisle to schedule the necessary inspection and acceptance of the project prior to issuance of the Carlisle warranty.

1.05 Warranty

- A. A Total System Warranty is available for roofing systems on commercial buildings within the United States and applies only to **products manufactured or marketed by Carlisle SynTec**. The total system is defined as membrane, flashings, adhesives, sealants and other Carlisle brand products utilized in the installation. For a complete description of these products, refer to the Part 2 "Products" Section in this Specification and **Spec Supplement "Related Products" P-01-22**.
- B. See Tables Below for Information regarding Warranted Systems and Design Criteria:
1. **TABLE I – Non-Reinforced EPDM Membrane Thickness for Various Warranty Options** Identifies minimum membrane thickness for non-reinforced membranes used in adhered or ballasted roofing systems.
 2. **TABLE II – Reinforced EPDM Membrane Thickness for Various Warranty Options** Identifies minimum membrane thickness required for adhered and mechanically fastened assemblies using Reinforced Membrane.
 3. **TABLE III – Mechanically Fastened Roofing Systems - Membrane Fastening Criteria – Up to 20 YR Warranty - Steel/Concrete Decks** Identifies fastening density, field membrane width and number perimeter sheets required for the various wind zones. The assemblies are categorized based on various building height and specific wind speed warranty coverage.
 4. **TABLE IV – Mechanically Fastened Roofing Systems - Membrane Fastening Criteria – Up to 20 YR Warranty - Wood (Plywood & OSB) Decks** Identifies fastening density, field membrane width and number perimeter sheets required for the various wind zones. The assemblies are categorized based on various building height and specific wind speed warranty coverage.
 5. **TABLE V – Re-roofing Substrate Criteria - Up to 20 YR Warranty** Identifies required substrates for re-roofing applications for adhered, mechanically fastened and ballasted roofing systems.
 6. **TABLE VI – Adhered Roofing Systems - Underlayment Fastening Criteria - Up to 20 YR Warranty** Identifies required underlayment for adhered roofing systems with Warranties up to 20 years based on the various wind speed coverage available. The Table also identifies fastening density or adhesive bead spacing and required edge terminations.
 7. **TABLE VII – Adhered Roofing Systems – Underlayment Fastening Criteria - 25 to 30 YR Warranty** Identifies required underlayment for adhered roofing systems with Warranties from 25 to 30 year based on the various wind speed coverage available. The Table also identifies fastening density or adhesive bead spacing and required edge terminations.

Table I Non-Reinforced EPDM Membrane Thickness for Various Warranty Options

Warranty Duration	Sure-Seal or Sure-White Non-Reinforced Membranes					
	Warranty Wind Speed Coverage				Minimum Membrane Thickness	Hail Coverage
	55, 72 or 80 mph		90 to 100 mph	110 to 120 mph		*(Cover Board set in Adhesive)
	Adhered	Ballasted	Adhered	Adhered		
5,10, 15 or 20 year		√ (2)			Sure-Seal 45-mil	1" for Ballasted
5, 10, or 15 year	√	√ (2)	√	√	60-mil Sure-Seal OR Sure-White	1" for Adhered*
						2" for Ballasted
20 year	√	√ (2)	√	√	60-mil Sure-Seal OR Sure-White	1" for Adhered*
						2" for Ballasted
25 year (3)	√ (1)	√	√ (1)	N/A	60-mil Sure-Seal OR Sure-White	1" for Adhered*
						2" for Ballasted
30 year (3)	√ (1)	√	√ (1)	N/A	90-mil Sure-Seal OR Sure-White	2" for Adhered*
						3" for Ballasted

Notes: N/A = Not Acceptable √= Acceptable

(1) Standard 90-8-30A, EPDM x-23 Low-VOC or CAV-GRIP III Bonding Adhesive must be utilized.

(2) When Sure-Tough Reinforced membrane is specified, 60-mil membrane minimum is required for warranties for up to 15 year. Projects with 20 Year Warranty must incorporate 75-mil membrane.

(3) See Attachment II '25/30 Year Warranty Design Enhancements' for enhanced design requirements.

Table II Reinforced EPDM Membrane Thickness for Various Warranty Options

Warranty Duration	Sure-Tough or Sure-White Reinforced Membranes								
	Warranty Wind Speed Coverage						Minimum Membrane Thickness	Hail Coverage	Puncture Coverage
	55, 72 or 80 mph		90 mph		100 to 120 mph			*(Cover Board set in Adhesive)	
	Adhered	Mech. Fastened	Adhered	Mech. Fastened	Adhered	Mech. Fastened			
5,10, or 15 year	√	√	√	√	√	N/A	45-mil Sure-Tough	N/A	8 man hours
20 year	√	√	√	√	√	N/A	60-mil Sure-Tough or Sure-White Reinforced	1" for Adhered*	16 man hours
25 year (2)	√ (1)	√	√ (1)	√	√ (1)	N/A	75-mil Sure-Tough	2" for Adhered*	32 man hours
30 year (2)	√ (1)	√	√ (1)	√	√ (1)	N/A	75-mil Sure-Tough	2" for Adhered*	32 man hours

Notes: N/A = Not Acceptable √= Acceptable

(1) Standard 90-8-30A, EPDM x-23 Low-VOC or CAV-GRIP III Bonding Adhesive must be utilized.

(2) See Attachment II '25/30 Year Warranty Design Enhancements' for enhanced design requirements.

**Mechanically Fastened Roofing Systems Fastening Criteria
Up to 20 YR Warranty (1)
22 GA. Steel and Structural Concrete Decks**

Table III

Peak Gust Wind Speed Warranty	Max. Building Height	Min. Number of Perimeter Sheets			Field Membrane Width	Perimeter Sheet Width	Fastening Density* (Field & Perimeter Sheets)
		Building Distance from Coastline					
		Greater than 7 miles	3 to 7 miles	Less than 3 miles			
55 MPH	Up to 60'	1	2	3	10'	6.5'	12" O.C.
					8'	6.5'	12" O.C.
	61' to 100'	2	2	3	10'	6.5'	6" O.C.**
					8'	6.5'	12" O.C.
72 MPH	Up to 60'	2	2	3	10'	6.5'	12" O.C.
					8'	6.5'	12" O.C.
	61' to 100'	3	4	4	10'	6.5'	6" O.C.**
					8'	6.5'	12" O.C.
80 MPH	Up to 60'	3	3	4	10'	5****	12" O.C.
					8'	5****	12" O.C.
	61' to 100'	3	4	4	10'	5****	6" O.C.**
					8'	5****	12" O.C.
90 MPH (1)	Up to 60'	3	4	4	10'	5****	6" O.C.**
					8'	5****	12" O.C.
	61' to 100'	4	5	5	10'	5****	6" O.C. **
					8'	5****	12" O.C.

* Using HP Fasteners on Steel Deck with Polymer Seam Plates

**12" o.c. Spacing can be utilized by using HP-Xtra Fasteners and 2-3/8" Polymer Seam Plates.

***As an option, 9" wide EPDM Pressure Sensitive RUSS can be used beneath the field sheets for perimeter securement.

(1) 20 year is the maximum warranty available with peak gust wind speed of 90 MPH. Projects with greater wind speed coverage **MUST** be submitted to Carlisle for review and possible considerations.

**EPDM Membrane Fastening Criteria
(Up to 20 Year Warranty – Up to 60' Building Height)
for Mechanically Fastening Roofing Systems
Wood (Plywood or OSB) Decks**

TABLE IV

Wood (Plywood or OSB) Decks Peak Gust Wind Speed Warranty	Deck Type	Projected Pull-Out Values	Min. Number of Perimeter Sheets			Field Membrane Width	Perimeter Sheet Width	Fastening Density (Field & Perimeter Sheets)
			Building Distance from Coastline					
			Greater than 7 miles	3 to 7 miles	Less than 3 miles			
55 MPH	7/16" OSB	210 lbs	2	3	3	10'	5"	9" O.C.
			2	3	3	8'	5"	12" O.C.
	15/32" 3-Ply Plywood	240 lbs	2	2	3	8'	5"	12" O.C.
	15/32" 5-Ply Plywood	530 lbs	1	1	1	10'	6.5'	12" O.C.
	5/8" OSB	310 lbs	2	3	3	10'	5"	12" O.C.
			2	3	3	8'	5"	12" O.C.
72 MPH	15/32" 3-Ply Plywood	240 lbs	2	2	3	8'	5"	12" O.C.
	15/32" 5-Ply Plywood	530 lbs	1	1	1	10'	6.5'	12" O.C.
	5/8" OSB	310 lbs	2	3	3	10'	5"	12" O.C.
			2	3	3	8'	5"	12" O.C.
80 MPH	<i>Contact Carlisle for Approval and Evaluation</i>							

*Maximum duration for OSB NOT to exceed 20 Years.

Table V Re-roofing Substrate Criteria - Up to 20 YR Warranty

Acceptable Roof Deck/Substrate	EPDM Membrane (See Table I and II for minimum membrane thickness)		
	Adhered - Design "A"	Ballasted - Design "B"	Mechanically Fastened
RETROFIT / NO TEAR-OFF	Adhered - Design "A"	Ballasted - Design "B"	Mechanically Fastened
Existing Smooth Surface BUR or Mineral Surface Cap Sheet	Direct Application (1)	Insulation	Direct Application (1)
Gravel Surfaced BUR	Insulation	Insulation	Insulation
Coal Tar Pitch	Insulation	Insulation	Insulation
Modified Bitumen	Direct Application (1)	Insulation	Direct Application (1)
Existing Single-Ply	Insulation	Insulation	Direct Application (1) (2)
Sprayed-in-place Urethane	Complete Tear-off Required	Insulation	Complete Tear-off Required

(1) Direct application permitted for projects with warranties up to 15 YR unless specifically approved by Carlisle. For acceptable insulations, when 20 YR warranty is required refer to Table VI paragraph 1.05.

(2) Direct application over existing PVC is not permitted regardless of warranty duration. Carlisle may be contacted for specific substrate requirement.

NOTE: Projects with Warranties greater than 20 YR require total removal of existing materials. Refer to Table VI and VII for further material requirements.

NOTE: Refer to Roof Deck and Substrate Criteria Table in Part III for additional installation requirements.

Adhered Roofing Systems Underlayment Fastening Criteria Up to 20 YR Warranty

Table VI

Other Requirements are Listed in Additional Design Considerations following this Table

All Carlisle Products listed for higher wind speed coverage can also be used for Warranties for lower speed coverage.
(i.e. 72 MPH underlayment may be used for 55 MPH underlayment)

Maximum Peak Gust Wind Speed Warranty	Minimum Membrane Underlayment	Underlayment Attachment		Metal Edging	
		# of Fasteners per 4' x 8' board size (1)	Adhesive Ribbon Spacing for 4' x 4' size board		
			Field		Perimeter
55 or 72 MPH	1" (20 psi) Polyisocyanurate	16(10)	12" (5)(6)	6" (5)	Carlisle Drip Edge, SecurEdge™ 200
	1-1/2" (20 psi) Polyisocyanurate	10			
	2" (20 psi) Polyisocyanurate	8			
	1/2" SecurShield HD	12			
	1/4" DensDeck Prime or 1/4" Securock	12			
80 MPH	1/2" SecurShield HD Plus	8	12" (5)(6)(7)	6' (5)(7)	Carlisle Drip Edge, SecurEdge 200 (11)
	1/2" HP Recovery Board (2)	16			
	2" SecurShield HD Composite	6			
	1/2" DensDeck Prime or 1/2" Securock (2)	8			
	1-1/2" Polyisocyanurate (25-psi)	10			
	2" (25-psi) Polyisocyanurate	8			
90 MPH	1/2" DensDeck Prime or 1/2" Securock (2)	12	6" (9)	6' (7)(8)	Carlisle Drip Edge (3), SecurEdge 200 (3)(4) or SecurEdge 2000 or 3000
	1/2" SecurShield HD or 1-1/2" (20-psi) SecurShield Polyiso	16			
	1/2" SecurShield HD Plus or 1/2" EcoStorm VSH (2)	12			
	2" (20-psi) SecurShield or 2" SecurShield HD Polyiso Composite	8			
	1-1/2" StormBase (OSB/Polyiso Composite)	8			
	1-1/2" Insulfoam HD Composite	16			
100 MPH	2" (25-psi) SecurShield Polyiso (1)	16	FS	FS	Carlisle Drip Edge (3), SecurEdge 200 (3)(4) or SecurEdge 2000 or 3000
110 MPH	1-1/2" StormBase (OSB/Polyiso Composite) or 1/2" EcoStorm VSH (2)	16	FS	FS	SecurEdge 2000 or 3000
	1/2" SecurShield HD Plus				
120 MPH	5/8" DensDeck Prime or 5/8" DensDeck StormX Prime or 5/8" Securock (2)	16	FS	FS	SecurEdge 2000 or 3000
	1-1/2" StormBase (OSB/Polyiso Composite) (1) or 1/2" EcoStorm VSH (2)	17			
	1/2" SecurShield HD Plus	24			
	2" SecurShield HD Composite	16			

FS = Full Spray or Ribbons @ 4" O.C.

- (1) For Building heights between 51-100', enhance 12'-wide perimeter with 50% more fasteners and plates.
- (2) For Steel Decks, Cover boards must be installed over a min. 1" thick approved Carlisle Insulation.
- (3) Carlisle HP or HP-X Fasteners must be used to secure Carlisle Drip Edge or SecurEdge 200 Metal Fascia to perimeter wood nailers.
- (4) Membrane securement is required at the base of the SecurEdge 200 waterdam.
- (5) Gravel Surface BUR - Field @ 6" O.C. / Perimeter @ 4" O.C.
- (6) Steel Decks - Field & Perimeter @ 6" O.C.
- (7) Cementitious Wood Fiber - Field @ 6" O.C. / Perimeter @ 4" O.C.
- (8) Smooth BUR - Field @ 6" O.C. / Perimeter @ 4" O.C.
- (9) Gravel Surface BUR – FS
- (10) Reduced fastening (11 fasteners per 4x 8 board) is acceptable on Reroof/No Tear off projects with a maximum roof height of 40'.
- (11) May be fastened with ring shank nails staggered 4" on center. Carlisle HP or HP-X Fasteners may also be used fastened 12" on center.

Additional Adhered Design Considerations - Up to 20 YR Warranty

- 1 - Building height shall not exceed 100'
- 2 - Local Wind Zone per ASCE 7 shall not exceed 130 mph*
- 3 - Acceptable decking: 22-gauge or heavier steel, structural concrete, 1-1/2" wood plank, or 15/32" plywood.

* For projects where building height exceeds 100', please submit to Carlisle for review.

**Underlayment/Insulation & Required Attachment Assemblies
Up to 20 YR Warranty for SAT EPDM Adhered Roofing Systems**

Table VII

Other Requirements are Listed in Additional Design Considerations following this Table

All Carlisle Products listed for higher wind speed coverage can also be used for Warranties for a lower speed coverage. (i.e. 72 MPH underlayment may be used for 55 MPH underlayment)

Peak Gust Wind Speed Warranty	Minimum Membrane Underlayment	Insulation Attachment			Metal Edging
		# of Fasteners per 4' x 8' board size (1)	Adhesive Ribbon Spacing for 4' x 4' size board		
			Field	Perimeter	
55 or 72 MPH	1" (20 psi) Polyisocyanurate	16 (9)	12" (4)(5)	6" (4)	Carlisle Drip Edge, SecurEdge 200
	1-1/2" (20 psi) Polyisocyanurate	10			
	2" (20 psi) Polyisocyanurate	8			
	1/2" SecurShield HD	12			
	1/4" DensDeck Prime or 1/4" Securock				
2" (1.25 lb/density) Insulfoam SP*					
80 MPH	1/2" DensDeck Prime or 1/2" Securock (2)	8	12" (4)(5)(6)	6" (4)(6)	Carlisle Drip Edge, SecurEdge 200 (12)
	1/2" SecurShield HD	16			
	1/2" SecurShield HD Plus (3)	8			
	2" SecurShield HD Composite	6			
	1-1/2" (25-psi) Polyisocyanurate	10			
	2" (25 -psi) Polyisocyanurate	8			
	2" (1.25 lb/density) Insulfoam SP**	16			
1-1/2" Insulfoam HD Composite*	12	12"(8)	6"(6)(7)		
90 MPH	1/2" DensDeck Prime or 1/2" Securock (2)	12	6" (8)	6" (6)(7)	Carlisle Drip Edge (10), SecurEdge 200 (10)(11) or SecurEdge 2000 or 3000.
	1/2" SecurShield HD or 1-1/2" (20-psi) SecurShield Polyiso	16			
	1/2" SecurShield HD Plus or 1/2" EcoStorm VSH	12			
	1-1/2" StormBase (OSB/Polyiso Composite)	8			
	2" (20-psi) SecurShield Polyiso or 2" SecurShield HD Composite	8			
	1-1/2" Insulfoam HD Composite	16			
100 MPH	5/8" DensDeck Prime or 5/8" DensDeck StormX Prime or 5/8" Securock (2)	16	FS	FS	Carlisle Drip Edge (10), SecurEdge 200 (10)(11) or SecurEdge 2000 or 3000.
	1/2" SecurShield HD Plus				
	1-1/2" StormBase (OSB/Polyiso Composite) or 1/2" EcoStorm VSH				
	2" (25-psi) SecurShield Polyiso (1)				
	2" SecurShield HD Composite				

FS = Full Spray or Ribbons @ 4" O.C.

- (1) For Building heights between 51-100', enhance 12'-wide perimeter with 50% more fasteners and plates.
 - (2) Cover boards must be installed over a min. 1" thick approved Carlisle Insulation.
 - (3) Not used.
 - (4) Gravel Surface BUR - Field @ 6" O.C. / Perimeter @ 4" O.C.
 - (5) Steel Decks - Field & Perimeter @ 6" O.C.
 - (6) Cementitious Wood Fiber - Field @ 6" O.C. / Perimeter @ 4" O.C.
 - (7) Smooth BUR - Field @ 6" O.C. / Perimeter @ 4" O.C.
 - (8) Gravel Surface BUR - FS
 - (9) Reduced fastening (11 fasteners per 4 x 8 board) is acceptable on Reroof/No Tear off projects with a maximum roof height of 40'.
 - (10) Carlisle HP or HP-X Fasteners must be used to secure Carlisle Drip Edge or SecurEdge 200 Metal Fascia to perimeter wood nailers.
 - (11) Membrane securement is required at the base of the SecurEdge 200 waterdam.
 - (12) May be fastened with ring shank nails staggered 4" on center. Carlisle HP or HP-X Fasteners may also be used fastened 12" on center.
- *Maximum warranty available 20 year.
** Maximum warranty available 15 year.

Additional Design Considerations (Up to 20 YR Warranty)

- 1 - Minimum membrane thickness 60-mil SAT EPDM
- 2 - Building height shall not exceed 100'
- 3 - Local Wind Zone per ASCE 7 shall not exceed 130 mph*
- 4 - Acceptable decking: 22-gauge or heavier steel, structural concrete, 1-1/2" wood plank, or 15/32" plywood.
- 5- All "T-joints" must be overlaid with appropriate flashing material or Carlisle "T-Joint" Covers.

* Projects where building height exceeds 100' or warranty wind speed exceeds 100 mph, shall be submitted to Carlisle for review.

**Underlayment Fastening Criteria
25 YR or 30 YR Warranty**

Table VIII

Other Requirements are Listed in Additional Design Considerations following this Table

All Carlisle Products listed for higher wind speed coverage can also be used for Warranties for lower speed coverage. (i.e. 72 MPH underlayment may be used for 55 MPH underlayment)

Maximum Peak Gust Wind Speed Warranty	Minimum Membrane Underlayment	Underlayment Attachment			Metal Edging
		# of Fasteners per 4' x 8' board size (1)	Adhesive Ribbon Spacing for 4' x 4' size board		
			Field	Perimeter	
55 or 72 MPH	1" to 2" (25 psi) Polyisocyanurate	16	6" (3)(5)	6" (5)	Carlisle Drip Edge, SecurEdge 200 (9)
	1/2" HP Recovery Board (1)(10)				
	1/4" DensDeck Prime or 1/4" Securock				
	1/2" SecurShield HD (2)				
80 MPH	1-1/2" to 2" (25-psi) SecurShield Polyisocyanurate	20	6" (4)(5)(6)	6" (5)(6)	Carlisle Drip Edge (7), SecurEdge 200 (7)(8) or SecurEdge 2000 or 3000.
	1/2" DensDeck Prime or 1/2" Securock (2)	16			
	1/2" SecurShield HD Plus (2)	20			
	1/2" SecurShield HD (2)	20			
90 MPH	1/2" SecurShield HD (2)	24	FS	FS	SecurEdge 2000 or 3000
	1/2" SecurShield HD Plus (2)	20			
	1/2" DensDeck Prime or 1/2" Securock (2)				
100 MPH	5/8" DensDeck Prime or 5/8" DensDeck StormX Prime or 5/8" Securock (2)	16	FS	FS	SecurEdge 2000 or 3000
	1-1/2" StormBase (OSB/Polyiso Composite) or 1/2" EcoStorm VSH (2)				
	2" SecurShield HD Composite (2)				
	1/2" SecurShield HD Plus (2)	24			

FS = Full Spray or Ribbons @ 4" O.C.

(1) For Building heights between 51-100', enhance 12'-wide perimeter with 50% more fasteners and plates.

(2) Hail coverage offered with substrate.

(3) Structural Concrete - Field @ 12" O.C. / Perimeter @ 6" O.C.

(4) 80-mph over structural concrete - Field & Perimeter @ 6" O.C.

(5) Cementitious Wood Fiber & Wood – FS

(6) 80-mph over Gypsum Decks – FS

(7) Carlisle HP or HP-X Fasteners must be used to secure Carlisle Drip Edge or SecurEdge 200 Metal Fascia to perimeter wood nailers.

(8) Membrane securement is required at the base of the SecurEdge 200 waterdam.

(9) May be fastened with ring shank nails staggered 4" on center. Carlisle HP or HP-X Fasteners may also be used fastened 12" on center.

(10) 1/2" Recovery Board limited to 55 mph.

Additional Adhered Design Considerations - 25 YR to 30 YR Warranty

1 - Building height shall not exceed 100'

2 - Local Wind Zone per ASCE 7 shall not exceed 130 mph*

3 - Acceptable decking: 22-gauge or heavier steel, structural concrete, 1-1/2" wood plank, or 15/32" plywood.

C. Access for warranty service

It shall be the owner's responsibility to expose the membrane in the event warranty service is required when access is impaired. Such impairment includes, but is not limited to:

1. Design features, such as window washer systems, which require the installation of traffic surface units in excess of 100 pounds per unit.
2. Any equipment, ornamentation, building service units and other top surfacing materials, which are not defined as part of this specification.
3. Photovoltaic and Mounting Systems or other Rooftop equipment which does not provide Carlisle with reasonable access to the membrane system for purposes of warranty investigation and related repairs.
4. Severely ponded conditions.

CAUTION: APPLICATIONS SUCH AS WALKING DECKS, TERRACES, PATIOS OR AREAS SUBJECTED TO CONDITIONS NOT TYPICALLY FOUND ON ROOFING SYSTEMS WILL **NOT** BE ELIGIBLE FOR A MEMBRANE SYSTEM WARRANTY. CARLISLE MAY BE CONTACTED FOR OTHER AVAILABLE OPTIONS.

- D. The formation or presence of mold or fungi in a building is dependent upon a broad range of factors including, but not limited to, the presence of spores and nutrient sources, moisture, temperatures, climatic conditions, relative humidity, and heating/ventilating systems and their maintenance and operating capabilities. These factors are beyond the control of Carlisle and Carlisle shall not be responsible for any claims, repairs, restoration or damages relating to the presence of any irritants, contaminants, vapors, fumes, molds, fungi, bacteria, spores, mycotoxins, or the like in any building or in the air, land, or water serving the building.

1.06 Job Conditions

- A. On phased roofing, temporary closures should be provided to prevent moisture infiltration. When a temporary roof is specified, Carlisle 725TR in conjunction with CCW-702, CCW-702 LV or CAV-GRIP III Primer may be used. Refer to Product Section Part II for additional product information and **Spec Supplement G-08-20 "Application Procedures for 725TR Air and Vapor Barrier"**.
- B. When possible, on multiple level roofs, begin the installation on the highest level to avoid or minimize construction traffic on completed roof sections.
- C. On projects at high altitudes (6,000' and above) rapid flash-off (drying) of Bonding Adhesive and Primers will occur due to low atmospheric pressure.
- D. Vapor Retarders
1. Carlisle does not require a vapor retarder for the protection of the membrane; however, it should be considered by the specifier for the protection of the roofing assembly (i.e. primarily insulation, underlayment and adhesives). The following criteria should be considered by the specifier:
 - a. Use of a vapor retarder to protect insulation and reduce moisture accumulation within an insulated roofing assembly, should be investigated by the specifier. Consult latest publications by ASHRAE (American Society of Heating, Refrigerating and Air-Conditioning Engineers, Inc.) and NRCA (National Roofing Contractors Association) for specific information.
 - b. In the generally temperate climate of the United States, during the winter months, water vapor flows upward from a heated, more humid interior toward a colder, drier exterior. Vapor retarders are more commonly required in northern climates than in southern regions, where downward vapor pressure may be expected and the roofing membrane itself becomes the vapor retarder.

- c. On cold storage/freezer facilities, the perimeter and penetration details must be selected to provide an air seal and prevent outside air from infiltrating and condensing within the roofing assembly.
2. When a vapor retarder is specified, Carlisle VapAir Seal 725TR or VapAir Seal MD Air and Vapor Barrier may be used. Refer to Part II “Products” for necessary information and **Spec Supplement G-08-20 “Application Procedures for 725TR Air and Vapor Barrier”** for product Installation.
- E. Wood nailers are required for the securement of metal edgings, deck-level scuppers, and insulated pipes. Treated or non-treated wood nailer may be specified and shall be secured per specifier recommendation or in accordance with Factory Mutual’s property Loss Prevention Data Sheet 1-49. Refer to **Design Reference DR-08-11 “Wood Nailers and Securement Criteria”** in Carlisle Technical Manual shall be referenced.
 - F. For Adhered or Mechanically Fastened systems specified over existing standing seam, flat seam or corrugated metal roofs, refer to the Carlisle’s Metal Retrofit Roofing System Specification in the Carlisle Technical Manual for specific installation requirements.
 - G. When any of the EPDM Roofing Systems are specified on a portion of a roof, tie-ins to existing roofing membranes will be required. Depending on the type of the existing roofing system, the tie-in method will vary. Total isolation between two roofing systems or weep holes may be required to address moisture migration from one roofing system to the other. Prior to the selection of any tie-in detail, ensure the selected detail will not restrict drainage.

1.07 Product Delivery, Storage and Handling

- A. Deliver materials to the job site in original, unopened containers.
- B. When loading materials onto the roof, the Carlisle Authorized Roofing Applicator must comply with the requirements of the specifier/owner to prevent overloading and possible disturbance to the building structure.
- C. Job site storage temperatures in excess of 90°F (32°C) may affect shelf life of curable materials (i.e., uncured flashing, adhesives, sealants, primers, SecurTAPE and Pressure-Sensitive Flashing/Accessories).
- D. **When the temperature is expected to fall below 40°F (4°C)**, outside storage boxes should be provided on the roof for temporary storage of liquid adhesives, sealants, primers, SecurTAPE and Pressure-Sensitive Flashing/Accessories. Containers must be rotated to maintain their temperature above 40°F (4°C). Refer to Product Data Sheets for individual products for temperature restrictions.

NOTE: Prolonged exposure of Pressure-Sensitive Flashing and SecurTAPE to temperatures below 40°F (4°C) will cause the pre-applied adhesive tape to lose tack and in extreme cases, not bond to the substrate. Refer to **Spec Supplement E-02-20 “EPDM Membrane Splicing and Splice Repairs”** in Carlisle Technical Manual for application procedures in colder temperatures.

- E. Do not store adhesive containers with opened lids due to the loss of solvent, which will occur from flash-off.
- F. Insulation/underlayment must be stored so it is kept dry and is protected from the elements. Store insulation on a skid and completely cover with a breathable material such as tarp or canvas. If the insulation is lightweight, it should be weighted to prevent possible wind damage.

Part II – PRODUCTS

2.01 General

The components of this roofing system are to be products of Carlisle or accepted by Carlisle as compatible. The installation, performance or integrity of products by others, **when selected by the specifier and accepted by Carlisle**, is not the responsibility of Carlisle and is expressly disclaimed by the Carlisle warranty.

2.02 Membrane

A. Sure-Seal/Sure-White Non-Reinforced EPDM Membranes

1. Cured non-reinforced EPDM (Ethylene, Propylene, Diene Terpolymer) compounded elastomer.

45 (Black Membrane Only), 60, or 90 mil thick Non-Reinforced EPDM membrane is available in **Sure-Seal (black) or Sure-White (white-on-black)**. Sure-White membranes are installed with the white surface facing up. Sure-Seal membrane with thickness up to 60-mil can be available in widths up to 50' and lengths up to 150' (200' for 45-mil membrane only). Sure-White membrane with thickness of 60-mil is available up to 20' widths and lengths up to 150' long. Sure-Seal /Sure-White 90-mil membranes are available in widths up to 10' and lengths up to 100'. Membrane conforms to ASTM D4637, Type I (non-reinforced).

2. **Sure-Seal KLEEN (black) EPDM Membrane** (mica dust has been removed during manufacturing) is available for sheets maximum 10' wide.
3. Refer to the physical properties listed on the following pages.

B. Sure-Tough Reinforced EPDM Membranes

1. Cured reinforced EPDM (Ethylene, Propylene, Diene Terpolymer) compounded elastomer. **Sure-Tough Reinforced EPDM Membrane** is only available in black.

45, 60, or 75-mil thick Sure-Tough Reinforced EPDM membrane is available in sizes referenced in Table below. Reinforced membrane with polyester fabric conforms to ASTM D4637, Type II (reinforced).

Sure-Tough Reinforced Membrane Size Availability*			
Membrane Thickness	Sheet Sizes		
45-mil	5' or 6.5' x 100'	-	10' x 50' or 100'
60-mil	5' or 6.5' x 100' 5' x 200'	8' x 100'	10' x 50' or 100'
75-mil	-	-	10' x 50' or 100'

*Contact Carlisle for other custom sizes available.

2. **60-mil thick Sure-White Reinforced EPDM** membrane is available in a 10' x 100' sheet size.
3. Refer to the physical properties listed on the following pages:

STANDARD AND FIRE RETARDANT (FR)

45-mil thick Sure-Seal (standard) non-reinforced EPDM membrane is used only for Sure-Seal Design "B" Loose Laid Ballasted Roofing Systems.

60 or 90-mil thick Sure-Seal FR (black) or Sure-White (white on black) non-reinforced EPDM membrane is used primarily for Adhered Roofing Systems. Either membrane can also be used for ballasted and protected membrane assemblies.

Note: Although 60-mil thick Non-Reinforced EPDM is recommended for Adhered Roofing Systems, 45-mil thick FR Non-Reinforced EPDM may be utilized, if specified.

SURE-SEAL/SURE-WHITE NON-REINFORCED MEMBRANES						
Physical Property	Test Method	ASTM SPEC. (Pass)	Typical			
			45-mil	60-mil	60-mil	90-mil
			Standard	FR	Sure-White	Sure-Seal FR / Sure-White
Tolerance on Nominal Thickness, %	ASTM D 412	±10	±10	±10	±10	±10
Weight, lb/ft ² (kg/m ²)			0.26 (1.3)	0.35 (1.7)	0.39 (1.9)	0.59 (2.9)**
Tensile Strength, min. psi (MPa)	ASTM D 412	1305 (9)	1600 (11)	1600 (11)	1600 (11)	1600 (11)
Elongation, Ultimate, min. %	ASTM D 412	300	480	465	540	540
Tear Resistance, min. lbf/in (kN/m)	ASTM D 624 (Die C)	150 (26.3)	200 (35.0)	200 (35.0)	200 (35.0)	200 (35.0)
Factory Seam Strength, min.	Modified ASTM D 816	Membrane Rupture	Membrane Rupture	Membrane Rupture	Membrane Rupture	Membrane Rupture
Resistance to Heat Aging* Properties after 4 weeks @ 240°F (116°C)	ASTM D 573					
Tensile Strength, min. psi (MPa)	ASTM D 412	1205 (8.3)	1500 (10.3)	1450 (10.0)	1345 (9.3)	1450 (10.0)
Elongation, Ultimate, min. %	ASTM D 412	200	225	280	280	280
Tear Resistance, min. lbf/in (kN/m)	ASTM D 624	125 (21.9)	215 (37.6)	215 (37.6)	185 (32.4)	215 (37.6)
Linear Dimensional Change, max. %	ASTM D 1204	±1.0	-0.4	-0.5	-0.2	-0.5
Ozone Resistance* Condition after exposure to 100 ppmh Ozone in air for 168 hours @ 104°F (40°C) Specimen is at 50% strain	ASTM D 1149	No Cracks	No Cracks	No Cracks	No Cracks	No Cracks
Brittleness Temp., max. deg. F (deg. C)*	ASTM D 746	-49 (-45)	-49 (-45)	-49 (-45)	-67 (-55)	-49 (-45)
Resistance to Water Absorption* After 7 days immersion @ 158°F (70°C) Change in mass, max. %	ASTM D 471	+8.0, -2.0	[+2]	[+2]	[+3.3]	[+2.0]
Water Vapor Permeance* max. perm	ASTM E 96 (Proc. B or BW)	0.1	0.05	0.03	0.02	0.03
Resistance to Outdoor (Ultraviolet) Weathering* Xenon-Arc, total radiant exposure at .70 W/m ² irradiance, 176°F (80° C) black panel temp.	ASTM D 4637 Conditions	No Cracks No Cracking @ 7560 kJ/m ²	No Cracks No Cracking @ 41580 kJ/m ²	No Cracks No Cracking @ 41580 kJ/m ²	No Cracks No Cracking @ 25200 kJ/m ²	No Cracks No Cracking @ 41580 kJ/m ² (black) 25200 kJ/m ² (white)

* Not a Quality Control Test due to the time required for the test or the complexity of the test. However, all tests are run on a statistical basis to ensure overall long-term performance of the sheeting.

** Sure-White 90-mil Membrane Weight in lb/ft²(kg/m²) is equal to 0.60 (2.9)

45, 60, or 75-MIL THICK REINFORCED EPDM MEMBRANE

The membrane is used for Adhered or Mechanically Fastened Roofing Systems

Sure-Tough membranes are formulated with fire retardants to inhibit spread of flame and meets or exceeds UL Class A requirements for slopes up to 3°, depending on the assembly.

SURE-TOUGH REINFORCED MEMBRANES					
Physical Property	Test Method	ASTM SPEC. (Pass)	Typical		
			45-mil	60-mil	75-mil
Tolerance on Nominal Thickness, %	ASTM D 751	±10	±10	±10	±10
Weight, lb/ft ² (kg/m ²)			0.27 (1.3)	0.39 (1.9)	0.48 (2.3)
Thickness Over Scrim, min. in.(mm)	ASTM D 4637 Annex	0.015 (.381)	0.016 (.406)	0.020 (.508)	0.032 (0.81)
Breaking Strength, min. lbf (N)	ASTM D 751 Grab Method	90 (400)	140 (623)	140(623)	177(787)
Elongation, Ultimate, min, %	ASTM D 751 Grab Method	250 **	480**	480**	500**
Tear Strength, min. lbf (N)	ASTM D 751 B Tongue Tear	10 (45)	70 (311)	70 (311)	70 (311)
Brittleness Temp., max. deg. F (deg. C)*	ASTM D 2137	[-49] (-45)	[-49] (-45)	[-49] (-45)	[-49] (-45)
Resistance to Heat Aging* Properties after 4 weeks @ 240°F	ASTM D 573				
Breaking Strength, min. lbf (N)	ASTM D 751	80 (355)	182 (823)	182 (823)	182 (823)
Elongation, Ultimate, min, %	ASTM D 751	200**	250**	250**	250**
Linear Dimensional Change, max. %	ASTM D 1204	±1.0	-1.0	-1.0	-1.0
Ozone Resistance* Condition after exposure to 100 ppm Ozone in air for 168 hours @ 104°F (40°C) Specimen wrapped around 3" mandrel	ASTM D 1149	No Cracks	No Cracks	No Cracks	No Cracks
Resistance to Water Absorption* After 7 days immersion @ 158°F (70°C) Change in mass, max. %	ASTM D 471	+8.0, -2.0	[+5.5**]	[+5.5**]	[+5.5**]
Factory Seam Strength, min.	Modified ASTM D 816	Membrane Rupture	Membrane Rupture	Membrane Rupture	Membrane Rupture
Resistance to Outdoor (Ultraviolet) Weathering* Xenon-Arc, total radiant exposure at .70 W/m ² irradiance, 176°F (80° C) black panel temp.	ASTM D 4637 Conditions	No Cracks No Cracking @ 7560 kJ/m ²	No Cracks No Cracking @ 35320 kJ/m ²	No Cracks No Cracking @ 35320 kJ/m ²	No Cracks No Cracking @ 35320 kJ/m ²
* Not a Quality Control Test due to the time required for the test or the complexity of the test. However, all tests are run on a statistical basis to ensure overall long-term performance of the sheeting.					
** Specimens to be prepared from coating rubber compound, vulcanized in a similar method to the reinforced product.					

60-MIL THICK REINFORCED EPDM MEMBRANE

The membrane is used for Mechanically Fastened or Adhered Roofing Systems.

Sure-Tough membranes are formulated with fire retardants to inhibit spread of flame and meets or exceeds UL Class A requirements for slopes up to 2°, depending on the assembly.

SURE-WHITE REINFORCED MEMBRANE			
Physical Property	Test Method	ASTM SPEC. (Pass)	Typical 60-mil
Tolerance on Nominal Thickness, %	ASTM D 751	±10	±10
Weight, lb/ft ² (kg/m ²)			0.40 (2.0)
Thickness Over Scrim, min. in.(mm)	ASTM D 4637 Annex	0.015 (.381)	0.025 (.635)
Breaking Strength, min, lbf (N)	ASTM D 751 Grab Method (1)	90 (400)	225(996)
Elongation, Ultimate, min, %	ASTM D 751 Grab Method	250 **	480**
Tear Strength, min, lbf (N)	ASTM D 751 B Tongue Tear	10 (45)	70 (311)
Brittleness Temp., max. deg. F (deg. C)*	ASTM D 2137	[-49] (-45)	[-49] (-45)
Resistance to Heat Aging* Properties after 4 weeks @ 240°F	ASTM D 573		
Breaking Strength, min, lbf (N)	ASTM D 751	80 (355)	250 (1,110)
Elongation, Ultimate, min, %	ASTM D 412	200**	250**
Linear Dimensional Change, max, %	ASTM D 1204	±1.0	-1.0
Ozone Resistance* Condition after exposure to 100 pphm Ozone in air for 168 hours @ 104°F (40°C) Specimen wrapped around 3" mandrel	ASTM D 1149	No Cracks	No Cracks
Resistance to Water Absorption* After 7 days immersion @ 158°F (70°C) Change in mass, max, %	ASTM D 471	+8.0, -2.0	5.2**
Water Vapor Permeance* Max. perms	ASTM E 96 (Proc. B or BW)	0.10	0.02
Fungi Resistance	ASTM G 21	N/A	0 (No Growth)
Specular Gloss at 85°C	ASTM D523	N/A	3
Resistance to Outdoor (Ultraviolet) Weathering* Xenon-Arc, total radiant exposure at .70 W/m ² irradiance, 176°F (80° C) black panel temp.	ASTM G 155	No Cracks No Crazing @ 2,520 kJ/m ² 1,000 hrs.	No Cracks No Crazing @ 25,200 kJ/m ² 10,000 hrs.
At 0.35 W/m ² irradiance, 80°C black panel temperature		2,000 hrs.	20,000 hrs.
* Not a Quality Control Test due to the time required for the test or the complexity of the test. However, all tests are run on a statistical basis to ensure overall long-term performance of the sheeting.			
** Specimens to be prepared from coating rubber compound, vulcanized in a similar method to the reinforced product.			

2.03 Insulations/Underlaysments

A. General

1. Roof insulation thickness must be determined by the thermal value required for each project and may be subject to code approval limitations. On projects where a vapor retarder is used, the specifier must calculate insulation thickness to ensure the temperature at the vapor retarder will not fall below the calculated dew point.
2. Multiple layers of insulation are recommended with all joints staggered between layers.
3. For minimum recommended R-Values, previously published by American Society of Heating and Air-Conditioning Engineers (ASHRAE), consult local building code official for applicable requirements.
4. For Insulation fastening pattern and densities refer to Carlisle Applicable Details and **Design Reference DR-05-21 “Insulation Fastening Patterns”**.
5. Carlisle Insulation/underlayment must be specified for all Total System Warranty projects or when the insulation is to be covered by the Carlisle Warranty. Any of the Carlisle Insulation/Underlayment may be specified subject to design restrictions included with each table.

B. Carlisle Polyisocyanurate

Table B1 Polyisocyanurate (See below for product descriptions)					
Insulations / Underlayment	Minimum Thickness	ASTM	Roofing System Acceptability		
			Adhered	Mechanically Fastened	Ballasted
Carlisle InsulBase Polyisocyanurate	*1.5"	C1289, Type II, Class 1, Grade 2 or 3	√	√	√
Carlisle InsulBase NH Polyisocyanurate	*1.5"	C1289, Type II, Class 1, Grade 2 or 3	√	√	√
Carlisle SecurShield Polyisocyanurate	*1.5"	C1289, Type II, Class 2, Grade 2 or 3	√	√	√
Carlisle SecurShield NH Polyisocyanurate	*1.5"	C1289, Type II, Class 2, Grade 2 or 3	√	√	√
Carlisle SecurShield HD Composite Polyisocyanurate (SS HD)	2"	C1289, Type IV, Grade 2 or 3	√	√	N/A
Carlisle StormBase Composite (OSB)	1.5"	C1289, Type V, Grade 2 or 3	√	√	N/A
Design Restrictions					
<ul style="list-style-type: none"> - Extended Warranty, those with longer duration, higher wind speed, or puncture coverage, may require the use of a cover board over Polyiso Insulation, refer to Warranty Tables in Paragraph 1.04 for applicable requirements. - Maximum Flute Spanability shall be limited to 2-5/8" when 1" Minimum Polyiso Insulation is to be used. - Minimum thickness of insulation board may be restricted by wind speed coverage and warranty duration, refer to Tables V and VI in Paragraph 1.05. - The use of HD Polyiso Composite roof insulation is not recommended for Ballasted Applications. *1.5" minimum for adhered systems. 1" minimum for mechanically fastened systems or as a base layer for adhered. 					
Notes: N/A = Not Acceptable √ = Acceptable					

SecurShield HD is listed in Paragraph E4 below.

1. **Carlisle InsulBase Polyisocyanurate** – A foam core insulation board covered on both sides with a medium weight fiber-reinforced felt facer meeting ASTM C 1289, Type II, Class 1, Grade 2 (20 psi) or Grade 3 (25 psi). The product is available in 4' x 8' standard size with a thickness from 1 to 4 inches. 4' x 4' tapered panels are also available.
2. **Carlisle InsulBase NH Polyisocyanurate** - A foam core insulation board covered on both sides with a glass-reinforced felt meeting ASTM C 1289, Type II, Class 1, Grade 2 (20 psi) or Grade 3 (25 psi). The product is available in 4' x 4' and 4' x 8' standard size with a thickness from ½" to 4 inches. InsulBase NH contains zero halogenated flame retardants.
3. **Carlisle SecurShield Polyisocyanurate** – A foam core insulation board covered on both sides with a coated glass fiber mat facer meeting ASTM C 1289, Type II, Class 2, Grade 2 (20 psi) or Grade 3 (25 psi). The product is available in 4' x 8' standard size with a thickness from 1 to 4 inches. 4' x 4' tapered panels are also available. These flat board products feature a dark-colored coated-glass facer (CGF) on one side of the insulation board and a light-colored CGF on the other, labeled ReadyFlash. ReadyFlash Technology allows applicators to manage adhesive flash-off times by choosing between two different-colored facers on every board.

4. **Carlisle SecurShield NH Polyisocyanurate** - A foam core insulation board covered on both sides with a coated glass fiber mat facer meeting ASTM C 1289, Type II, Class 2, Grade 2 (20 psi) or Grade 3 (25 psi). The product is available in 4' x 4' and 4' x 8' standard size with a thickness from ½ inch to 4 inches. SecurShield NH contains zero halogenated flame retardants.
5. **Carlisle SecurShield HD Composite Polyisocyanurate** – Composite insulation panel comprised of ½-inch high-density (109 psi max) Polyiso cover board laminated during the manufacturing process to SecurShield rigid Polyiso roof insulation meeting ASTM C1289 Type IV, Grade 2 (20 psi) or Grade 3 (25 psi). Available in 4' x 8' boards with thickness from 2" to 4.5". 4' x 4' panels are also available.
6. **Carlisle StormBase Polyisocyanurate Composite (OSB)** – Polyiso insulation bonded on the bottom side with a medium weight fiber-reinforced felt facer and laminated with a top surface of ⅞" or ¾" thick Oriented Strand Board (OSB) meeting ASTM C1289, Type V, Grade 2 (20 psi) or Grade 3 (25 psi). Available in 4' x 8' boards with thickness from 1-½" to 4".

C. EPS: Expanded Polystyrene

Table C1 EPS: Expanded Polystyrene (See below for product descriptions)					
Insulations / Underlayment	Minimum Thickness	ASTM	Roofing System Acceptability		
			Adhered	Mechanically Fastened	Ballasted
InsulFoam I	1"	C578 Type I	N/A	N/A	√
InsulFoam VIII	.75"	C578 Type VIII	N/A	N/A	√
InsulFoam II	.75"	C578 Type II	N/A	N/A	√
InsulFoam IX	.75"	C578 Type IX	N/A	N/A	√
InsulFoam HD Composite (SecurShield HD)	1.5"	C578 Type (I, VIII, II, or IX)	√	√	N/A
InsulLam (Various Cover Boards)	1.5"	C578 Type (I, VIII, II, or IX)	√	N/A	N/A
InsulFoam SP	1"	C578 Type VIII	√ (1)	√	√
Design Restrictions					
<ul style="list-style-type: none"> - Local Codes must be consulted regarding the acceptance of expanded insulation directly over steel decks. When specified, minimum thickness shall be designated by the manufacturer. - Expanded polystyrene roof insulations cannot be installed directly over coal-tar pitch roof surfaces or existing PVC membranes. A separation layer of minimum 1/2" SecurShield HD, HP Recovery Board or Polyiso Insulation shall be used. - (1) Adhered assemblies using Sure-Seal SAT or Sure-Tough SAT. 					
Notes: N/A = Not Acceptable √ = Acceptable					

R-Tech Fanfold Recover Board is listed in Paragraph E4 below.

1. **InsulFoam I** – A closed-cell lightweight expanded polystyrene (EPS) that meets ASTM C578, Type I. Nominal density of 1.0 lbs/cubic ft (pcf) available in 4' x 4' or 4' x 8' sizes with thickness from ¼" to 40". Custom lengths, widths and tapered boards are available. May be specified beneath Sure-Seal HP Recovery Board, DensDeck Prime, DensDeck StormX Prime or Securock.
2. **InsulFoam VIII** – A closed-cell lightweight expanded polystyrene (EPS) that meets ASTM C578, Type VIII. Nominal density of 1.25 lbs/cubic ft (pcf) available in 4' x 4' or 4' x 8' sizes with thickness from ¼" to 40". Custom lengths, widths and tapered boards are available. May be specified beneath Sure-Seal HP Recovery Board, DensDeck Prime, DensDeck StormX Prime or Securock.
3. **InsulFoam II** – A closed-cell lightweight expanded polystyrene (EPS) that meets ASTM C578, Type II. Nominal density of 1.5 lbs/cubic ft (pcf) available in 4' x 4' or 4' x 8' sizes with thickness from ¼" to 40". Custom lengths, widths and tapered boards are available. May be specified beneath Sure-Seal HP Recovery Board, DensDeck Prime, DensDeck StormX Prime or Securock.
4. **InsulFoam IX** – A closed-cell lightweight expanded polystyrene (EPS) that meets ASTM C578, Type IX. Nominal density of 2.0 lbs/cubic ft (pcf) available in 4' x 4' or 4' x 8' sizes with thickness from ¼" to 40". Custom lengths, widths and tapered boards are available. May be specified beneath Sure-Seal HP Recovery Board, DensDeck Prime, DensDeck StormX Prime or Securock.

5. **InsulFoam HD Composite** – InsulFoam expanded polystyrene (EPS) insulation laminated with a top surface of ½" thick SecurShield HD. Available in 4' x 8' boards with thickness from 1-½" to 7".
 6. **InsulLam** – InsulFoam expanded polystyrene (EPS) insulation laminated with a top surface of 7/16" or 5/8" thick Oriented Strand Board (OSB), 1/2" DensDeck Prime, 1/2" Securock, or 1/2" HP Recovery Board. Available in 4' x 8' boards with thickness from 1-½" to 7".
 7. **InsulFoam SP** – A closed-cell lightweight expanded polystyrene (EPS) with a factory-laminated fiber glass facer. Nominal density of 1.25 lbs/cubic ft (pcf), and meets ASTM C578, Type VIII. Designed for low-sloped roof applications that employ mechanically fastened or ballasted membranes. Can also be used in Adhered systems using Sure-Seal or Sure-Tough SAT Membranes.
- D. **XPS: Extruded Polystyrene** – Available through Carlisle is dimensionally stable with high thermal and low water absorption performance capability. XPS is available in varying compressive strengths thicknesses and sizes. Refer to specific product data sheets for physical properties and additional technical information.

Table D1 XPS: Extruded Polystyrene (See below for product descriptions)					
Insulations / Underlayment	Minimum Thickness	ASTM	Roofing System Acceptability		
			Adhered	Mechanically Fastened	Ballasted
Thermapink 18	.75"	Refer to Product Data Sheet	N/A	N/A	√
Thermapink 25	1"	Refer to Product Data Sheet	N/A	N/A	√
Foamular 400	1"	Refer to Product Data Sheet	N/A	N/A	√
Dow Styrofoam Deckmate Plus	1"	Refer to Product Data Sheet	N/A	N/A	√
Design Restrictions					
<ul style="list-style-type: none"> - Local Codes must be consulted regarding the acceptance of expanded insulation directly over steel decks. When specified, minimum thickness shall be designated by the manufacturer. - Expanded polystyrene roof insulations cannot be installed directly over coal-tar pitch roof surfaces or existing PVC membranes. A separation layer of minimum 1/2" SecurShield HD, HP Recovery Board or Polyiso Insulation shall be used. - Refer to related products listed in Spec Supplement P-01-22 "Related Products" for other products which may be suitable for use. Carlisle must be contacted for specific requirements. 					
Notes: N/A = Not Acceptable √ = Acceptable					

1. **Thermapink 18 or 25 Extruded Polystyrene**
2. **Foamular 400 Extruded Polystyrene**
3. **Dow Styrofoam Deckmate Plus Extruded Polystyrene**

E. **Carlisle Vacuum Insulated Panel (VIP)**

Table E1 Vacuum Insulated Panel (VIP) (See below for product descriptions)				
Insulations / Underlayment	Minimum Thickness	ASTM	Roofing System Acceptability	
			Adhered	Mechanically Fastened
Carlisle Optim-R VIP	*1.6"	C1484	√	N/A
Design Restrictions				
*2.6" minimum for total installed system including an additional 2 layers of 1/2" SecurShield HD panels; 1 layer on top and 1 layer on bottom of Optim-R. For adhered systems only. Note: Optim-R VIP cannot be cut or punctured.				
Notes: N/A = Not Acceptable √ = Acceptable				

1. **Optim-R Vacuum Insulated Panel (VIP)** – a high R-Value vacuum insulated panel (VIP) used to provide a low-profile solution when height restrictions exist, such as windows, doors, equipment curbs, etc. Provides an R-38 insulating value in a 2.6" system thickness with up to 35% infill (non-VIP material). Available in 23.6" x 23.6" and 23.6" x 47.2" board sizes.

F. Cover Boards / Slip Sheets

Table F1 Cover Boards (See below for product descriptions)					
Insulations / Underlayment	Minimum Thickness	ASTM	Roofing System Acceptability		
			Adhered	Mechanically Fastened	Ballasted
SecurShield HD	.5"	C1289-06, Type II, Class 4 (109 psi max)	√	√	N/A(2)
SecurShield HD Plus	.5"	C1289-06, Type II, Class 4 (109 psi max)	√	√	N/A(2)
InsulBase HD	.5"	C1289-06, Type II, Class 1, Grade 3	N/A	√	N/A
Securock Cover Board	.25"	Refer to Product Data Sheet	√	√	N/A
EcoStorm VSH	.5"	Refer to Product Data Sheet	√	√	N/A
HP Recovery Board	.5"	C208 Grade 2	√	√	√
DensDeck StormX Prime	.625"	C1177	√	√ (1)	N/A
DensDeck Prime	.25"	C1177	√	√ (1)	N/A
DensDeck	.25"	C1177	N/A	√ (1)	N/A
R-Tech Fanfold Recovery Board	.5"	C578 Type (I, VIII, II, or IX)	N/A	√	√
HP Protection Mat	6 oz	Refer to Product Data Sheets	N/A	√	√
Design Restrictions					
<ul style="list-style-type: none"> - HP Recovery Board and R-Tech Fanfold not recommended for direct use over Type B and F steel decks. - Securock Cover Board, HP Recovery Board, DensDeck Prime, DensDeck StormX Prime or DensDeck may not be used directly over New or Existing Lightweight Insulating Concrete Decks OR Structural Concrete. - Due to some warranty restrictions, DensDeck Prime, DensDeck StormX Prime and DensDeck not recommended for use directly over existing roofing membrane without prior written approval from Carlisle. Contact Carlisle for specific requirements. - R-Tech Fanfold primarily for use in existing roof re-covers applications or directly over structural or lightweight insulating concrete. - HP Protection Mat may be used for Ballasted systems over Lightweight Insulating Concrete with a Maximum Warranty duration of up to 15 years. To be used for Mechanically fastened on new construction projects with Lightweight Insulating Concrete, Fiber Cement or Gypsum Deck a Maximum Warranty duration of up to 15 years. 					
<p>(1) Permitted with roofs with slopes greater than 2" per foot for compliance with external fire codes, refer to UL listings or contact Carlisle. (2) Acceptable for some roof system designs, Contact Carlisle for recommendations.</p>					
Notes: N/A = Not Acceptable √ = Acceptable					

- SecurShield HD** - a rigid insulation panel composed of a high-density (109 psi max), closed-cell polyisocyanurate foam core laminated to coated-glass fiber-mat facer for use as a cover board or recover board. Available ½" thick 4' x 8' panel weight 11 lbs with an R-value of 2.5. These flat board products feature a dark-colored coated-glass facer (CGF) on one side of the insulation board and a light-colored CGF on the other, labeled ReadyFlash. ReadyFlash Technology allows applicators to manage adhesive flash-off times by choosing between two different-colored facers on every board.
- SecurShield HD Plus** - a rigid insulation panel composed of a high-density (109 psi max), closed-cell polyisocyanurate foam core laminated to premium-performance coated-glass fiber-mat facer for use as a cover board or recover board. Available ½" thick 4' x 8' panel weight 11 lbs with an R-value of 2.5. Meets an FM 1-90 using only 8 fasteners per 4' x 8' board.
- InsulBase HD** – a closed-cell polyisocyanurate foam core insulation board covered on both sides with glass-reinforced felt (GRF) facer meeting ASTM C 1289, Type II, Class 1, Grade 3. The product is available in 4' x 4' and 4' x 8' standard sizes with a thickness of one half inch.
- SECUROCK Cover Board** – A uniform composition of fiber-reinforced gypsum, without a facer, for use as a cover board or a thermal barrier. Available in ¼" to ⅝" thick and 4' x 4' or 4' x 8' size boards. Long uninterrupted runs (>200') may require slight gapping due to thermal expansion.
- EcoStorm VSH Cover Board** – an engineered composite building material made from a proprietary blend of plastic and cellulose fiber sourced from post-industrial and post-consumer waste streams. EcoStorm VSH is a durable, extremely moisture and mold resistant building material with a core that does not disintegrate or delaminate in the presence of water. Available in ½" thick and 4' x 8' size board.
- Sure-Seal HP Recovery Board** - A ½" or 1" thick high-density wood fiberboard with an asphalt coated facer for use as a cover board or recover board. Available ½" or 1" thick and 4' x 4' or 4' x 8' size boards. When used in reroof / no tear-off projects, warranty is limited to 15-year projects.

7. **DensDeck StormX Prime** – a reinforced gypsum cover board with an enhanced, moisture-resistant core and coated glass mat facers on the top and bottom side. The top surface is pre-primed and provides excellent bond strength for adhered membrane for use as a cover board. DensDeck StormX Prime is extremely durable and is approved for use in assemblies meeting FM's Very Severe Hail (VSH) Classification. Available in 5/8" thickness and 4' x 4' or 4' x 8' size boards.
8. **DensDeck Prime** – gypsum core that incorporates glass-mat facings on the top and bottom side. The top surface is pre-primed and provides excellent bond strength for adhered membrane for use as a cover board. Available in 1/4" to 3/8" and 4' x 4' or 4' x 8' size boards.
9. **DensDeck Cover Board** – gypsum core that incorporates glass-mat facings on the top and bottom side for use as a cover board. Available in 1/4" to 3/8" and 4' x 4' or 4' x 8' size boards.
10. **R-Tech FanFold Recover Board** – Closed-cell lightweight expanded polystyrene (EPS) with polymeric laminated faces which meets ASTM C 578, while metallic side used with EPDM. Available in thicknesses of 3/8" to 3/4" with coverage 4' x 50' (2 squares). 4' x 8' units are also available.
11. **HP Protection Mat** – A nominal 6-oz per square yard UV resistant polypropylene needle punched fabric used either above the membrane as a slip-sheet for ballast or as an underlayment to the membrane. Available 15' x 300' roll (4500 square foot) weighing 0.06 lbs per square foot.

2.04 Related Materials

A. Flashing

1. **Sure-Seal/Sure-White Pressure-Sensitive Cured Cover Strip:** A 6" or 9" wide and 100' long and 12" wide by 50' long Sure-Seal or Sure-White 60-mil cured EPDM membrane laminated to a nominal 30-mil cured Pressure-Sensitive TAPE. The Cured Cover Strip is ideal for flashing gravel stops, metal edging, Carlisle Seam Fastening Plates and for EPDM repairs.
2. **Sure-Seal Pressure-Sensitive Overlayment Strip:** A nominal 40-mil black, **semi-cured** EPDM membrane laminated to a nominal 30-mil cured, Pressure-Sensitive TAPE. Available in 6" and 9" widths and 100' long rolls used to overlay seams, flash gravel stops, metal edgings and Seam Fastening Plates used for additional membrane securement.
3. **Sure-Seal/Sure-White Pressure-Sensitive Elastoform® Flashing:** A 6" X 100' and 9" or 12" wide by 50' long, 60-mil thick Sure-Seal or Sure-White **uncured** EPDM Flashing laminated to a 30-mil Pressure-Sensitive TAPE used in conjunction with EPDM Primer.

Sure-Seal/Sure-White uncured Pressure-Sensitive Elastoform Flashing is used to flash inside and outside corners, pipes, scuppers and field fabricated pourable sealer pockets when the use of Carlisle pre-fabricated flashing accessories is not feasible.
4. **Sure-Seal/Sure-White Pressure-Sensitive Curb Flashing** – A 20" wide by 50' long Sure-Seal or Sure-White cured 60-mil thick EPDM membrane with 6" wide Pressure-Sensitive TAPE along one edge to be used to flash curbs/skylights, etc.
5. **Sure-Seal/Sure-White 20" Pressure-Sensitive Cured Flashing** - A 20" wide by 50' long Sure-Seal/Sure-White cured 60-mil thick EPDM membrane, with Pressure-Sensitive TAPE the full width already applied, used to flash curbs/skylights, etc.
6. **Sure-Seal/Sure-White Pressure-Sensitive "T" Joint Covers:** A factory cut uncured 60-mil thick EPDM flashing laminated to a nominal 30-mil Pressure-Sensitive TAPE, used to overlay field splice intersections and to cover field splices at angle changes; available in 6" x 6" and 12" x 12" sizes for Sure-Seal and 6" x 6" sizes for Sure-White.
7. **Sure-Seal or Sure-White Inside/Outside Corner:** A 7" x 9" precut 60-mil thick (black or white) Elastoform Flashing with a 30-mil Pressure-Sensitive TAPE; used for inside and outside corners, to overlay field splice intersections, and to cover field splices at angle changes.

8. **Sure-Seal/Sure-White Pressure-Sensitive Pipe Seals** with Pressure-Sensitive TAPE on the deck flange are available for use with Sure-Seal/Sure-White Roofing Systems:
 - a. Sure-Seal Pressure-Sensitive Pipe Seals are available in sizes: ½" to 3" and 1" to 6".
 - b. Sure-White Pressure-Sensitive Pipe Seals are available in one size: 1" to 6".
9. **Sure-Seal / Sure-White Pressure-Sensitive Pourable Sealer Pocket:** A pre-fabricated Pourable Sealer Pocket which consists of a 2" wide plastic support strip with Pressure-Sensitive, adhesive backed uncured Elastoform Flashing; available in 4", 6" and 8" diameters for Sure-Seal and 6" and 8" diameter for Sure-White.

B. Splice Tapes, Primers, Adhesives and Sealants/Cleaners

Refer to Product Data Sheets for material coverage rates and proper usage. Prior to the use of any of the products listed below, consult the Material Safety Data Sheets for applicable cautions and warnings.

1. **Sure-Seal or Sure-White Pressure-Sensitive SecurTAPE:** A 3" or 6" wide by 100' long splice tape used for splicing adjoining sections of EPDM membrane. 6" wide splice tape is used for Mechanically Fastened Roofing Systems and 20-year Warranty Systems. Complies with the South Coast Air Quality Management District Rule 1168.
2. **HP-250 EPDM Primer:** A solvent-based primer used to prepare the surface of EPDM membrane for application of SecurTAPE or Pressure-Sensitive products. Available in 1 or 3 gallon pails and as CAV-PRIME Pressurized Cylinders.
3. **Low-VOC EPDM and TPO Primer** - A Low-VOC (volatile organic compound) primer (less than 250 grams/liter) for priming of EPDM or TPO surfaces prior to application of FAT, Cover strip, SecurTAPE and all other pressure-sensitive products. Available in 1 or 3 gallon pails and as CAV-PRIME Pressurized Cylinders.
4. **Sure-Seal or Sure-White Lap Sealant:** A heavy-bodied material used at splice intersections beneath "T"-joint covers, at cut edges of reinforced EPDM membrane and around uncured pressure-sensitive accessories.
5. **Carlisle Weathered Membrane Cleaner:** A clear, solvent-based cleaner used to loosen and remove dirt and other contaminants from the surface of exposed EPDM membrane prior to applying Carlisle EPDM Primer. Available in 1 and 5-gallon pails.
6. **Low-VOC Membrane Cleaner:** A Low-VOC (volatile organic compound) cleaner (100% EPA-exempted solvents) used to loosen and remove dirt and other contaminants from the surface of exposed EPDM membrane prior to applying Carlisle EPDM Primer. Available in 1 and 5-gallon pails.
7. **90-8-30A Bonding Adhesive:** A high-strength, yellow colored, synthetic rubber adhesive used for bonding Sure-Seal/Sure-White EPDM membranes to various surfaces.
8. **EPDM x-23 Low-VOC Bonding Adhesive:** A Low-VOC (volatile organic compound) bonding adhesive (less than 250 grams/liter) used for bonding Sure-Seal/Sure-White EPDM membranes to various surfaces. Adhesive is available in 5 gallon pails.
9. **Low-VOC Bonding Adhesive:** A Low-VOC (volatile organic compound) bonding adhesive (less than 250 grams/liter) used for bonding Sure-Seal/Sure-White EPDM membranes to various surfaces. Adhesive is available in 5 gallon pails.
10. **Aqua Base 120 Bonding Adhesive:** A semi pressure-sensitive water based adhesive; used as a 2-sided contact adhesive for bonding Sure-Seal/Sure-White EPDM membrane to various surfaces. Complies with the South Coast Air Quality Management District Rule 1168.

11. **CAV-GRIP III Low-VOC Aerosol Contact Adhesive/Primer:** a low-VOC, methylene chloride-free adhesive that can be used for a variety of applications including: priming unexposed asphalt prior to applying Flexible FAST Adhesive, adhering Sure-Seal EPDM, horizontally, for the field of the roof, and for adhering Sure-Seal FleeceBACK and Sure-Seal EPDM membrane to vertical walls. Coverage rate is approximately 2,000-2,500 sq. ft. per 40 lb cylinder and 4,000-5,000 sq. ft. per 85 lb cylinder as a primer, in a single-sided application and 750 sq. ft. per 40 lb cylinder and 1,500 sq. ft. per 85 lb cylinder as an adhesive for vertical walls, in a double-sided application; 1,000 sq. ft. per 40 lb cylinder and 2,000 sq. ft. per 85 lb cylinder as an adhesive, horizontally, for the field of the roof, in a double-sided application.
12. **Water Cut-Off Mastic:** A one-component, low viscosity, self wetting, butyl blend mastic used as a sealing agent between the EPDM membrane and applicable substrates.
13. **Pourable Sealer:** A black, two-component, solvent-free, polyurethane based product used for tie-ins and as a sealant around hard-to-flash membrane penetrating objects such as clusters of pipes and for a daily seal when the completion of flashings and terminations cannot be completed by the end of each work day.
14. **One-Part Pourable Sealer:** A black, one-component, moisture curing, elastomeric polyether sealant used for attaching lightning rod bases and ground cable clips to the membrane surface and as a sealant around hard-to-flash penetrations such as clusters of pipes.
15. **Universal Single-Ply Sealant** A one-part polyether, non-sagging sealant designed for sealing expansion joints, control joints and counter flashings. Available in white or gray.

2.05 Fastening Components

A. Securement Strips (RUSS)

1. **Sure-Seal Pressure-Sensitive RUSS** (Reinforced Universal Securement Strip): A 6" or 9" wide, nominal 45-mil thick clean, cured reinforced EPDM black membrane with 3" wide Pressure-Sensitive Tape laminated along one edge for the 6" wide RUSS and along both edges for the 9" wide RUSS.
 - a. **6" wide Pressure-Sensitive RUSS** is used horizontally or vertically at the base of walls, curbs, etc., in conjunction with Fastening Plates or Bars below the EPDM deck membrane for additional membrane securement.
 - b. **9" wide Pressure-Sensitive RUSS** is utilized for perimeter membrane securement on Sure-Seal Mechanically Fastened Roofing Systems and primary securement on Metal Retrofit Roofing Systems.
2. **Sure-White Pressure-Sensitive RUSS** (Reinforced Universal Securement Strip): A 6" wide, nominal 45-mil thick clean, cured, reinforced EPDM membrane with 3" wide Pressure-Sensitive Tape laminated along one edge. Used on Sure-White Adhered Roofing Systems.

B. Fasteners

The following Table illustrates criteria for fastening of Carlisle Insulation with the referenced roof deck and includes minimum penetration requirements and pilot hole criteria.

Insulation Fastening Criteria

Deck Type	Carlisle Fasteners (1)	Min. Penetration	Pilot Hole Depth	Pilot Hole Diameter
Steel or Lightweight Insulating Concrete over Steel	ASAP or InsulFast™	3/4"	N/A	N/A
Structural Concrete, rated 3,000 psi or greater	CD-10	1"	Note (2)	7/32"
	HD 14-10	1"	Note (2)	3/16"
Wood Plank, min. 15/32" thick Plywood or min. 7/16" OSB	HP, ASAP or InsulFast	Min. 1" (3)	N/A	N/A
Cementitious Wood Fiber	Polymer Gyptec	1-1/2"	Note (4)	N/A
Cementitious Wood Fiber	Lite-Deck Fastener	2"	Note (4)	N/A
Gypsum	Polymer Gyptec	1-1/2"	Note (2)	7/16", 1/2" or 9/16" (5)
Gypsum	Lite-Deck Fastener	2"	Note (5)	Note (6)

Notes: N/A = Not Applicable

(1) Only 3" diameter insulation fastening plates can be used for insulation attachment.

(2) The pilot hole must be predrilled to a sufficient depth to prevent contact between the fastener point and any accumulated dust in the predrilled hole. This will help prevent bottoming out of the fastener during installation.

(3) For wood planks only, fastener penetration shall not exceed 1-1/2".

(4) Most cementitious wood fiber decks do not require pre-drilling; however, Carlisle should be contacted prior to installation for verification of specific types that may require a pilot hole to be predrilled.

(5) Pilot hole size may be varied to maximize pullout resistance.

(6) Gypsum hardness varies, and the desired pullout may determine pilot hole size. This could range from 1/4" to 5/16".

All Sure-Seal Fasteners listed below can be used with Sure-Seal or Sure-White Roofing Systems. Refer to the applicable specification for specific requirements.

- HP Fastener:** A threaded E-coat square head fastener for insulation and Reinforced membrane attachment for Mechanically Fastened Systems in conjunction with 2" diameter polymer seam plates. Used into steel, wood plank, minimum 1⁵/₃₂" thick plywood or minimum 7/16" thick oriented strand board (OSB).
- HP-Xtra Fastener:** An oversized diameter (.315") steel, threaded fastener used in conjunction with HP-Xtra Polymer Seam Plates for membrane securement into minimum 22 gauge steel or wood decks on Mechanically Fastened Roofing Systems.
- Pre-Assembled ASAP Fastener:** Carlisle's InsulFAST Fastener pre-assembled with a 3" diameter plastic plate used for insulation attachment only on Adhered and Mechanically Fastened Roofing Systems.
- InsulFast Fastener:** A threaded Phillips drive fastener used with Carlisle Insulation Plates for insulation attachment to steel or wood decks.
- HD 14-10 Concrete Fastener:** A #14 threaded fastener with a #3 Phillips drive used for minimum 3,000 psi concrete decks.
- CD-10 Fastener:** A hammer-driven, non-threaded E-Coat fastener for use with structural concrete decks rated 3,000 psi or greater.
- Polymer Gyptec Fastener:** A non-penetrating, plastic fastener and corresponding plate used with lightweight deck substrates such as fibrous cement and gypsum.
- Lite-Deck Fastener:** A deep, coarse threaded fastener used to secure insulation to gypsum and cementitious wood fiber decks in conjunction with Lite-Deck Plates.
- HP Term Bar Nail-In:** A 1-1/4" long expansion anchor with threaded drive pin used for fastening Sure-Seal Termination Bar or Seam Fastening Plates to concrete, brick or block walls. The fastener is set by hammering the drive pin into place.

C. Fastening Plates And Bars

- HP Polymer Seam Plate:** A 2" diameter plastic barbed fastening plate used with Carlisle HP Fasteners for membrane and Pressure-Sensitive RUSS securement for Mechanically Fastened Roofing Systems over steel roof decks.

2. **HP-Xtra Polymer Seam Plate:** A 2 3/8" diameter plastic barbed fastening plate used with HP-Xtra Fasteners for membrane and Pressure-Sensitive RUSS securement for Mechanically Fastened Roofing Systems over steel roof decks.
3. **Seam Fastening Plates:** A 2" diameter metal plate used for insulation attachment on Mechanically Fastened Roofing Systems or membrane securement on Adhered Roofing Systems in conjunction with the appropriate Carlisle Fastener.
4. **Insulation Fastening Plates:** A nominal 3" diameter metal plate used for insulation attachment in conjunction with the appropriate Carlisle Fastener.
5. **SecurFast Insulation Fastening Plates:** A nominal 2-7/8" hexagon metal plate used for insulation attachment in conjunction with the appropriate Carlisle Fastener.
6. **Accutrac Insulation Plates:** A nominal 3" square, recessed or flat bottomed, metal plate used for insulation attachment in conjunction with the appropriate Carlisle Fastener. Flat bottom plate is used with manufactured Philips Head fasteners only.
7. **Gyptec Plates:** A 3" (26 gauge) steel plate for insulation and a 2" (22 gauge) steel plate for membrane attachment. The plates are stamped galvalume-coated steel.
8. **Polymer Batten Strip:** A 1" wide by 1/20" thick polymer bar which is pre-punched 6" o. c. packaged in 250' long coils used for membrane securement on Mechanically Fastened Roofing Systems in conjunction with HP or HP-X Fasteners. Refer to applicable Product Data Sheets.
9. **Metal Fastening Bar:** A 1" wide metal bar which is pre-punched 6" o. c. and packaged in 10' long strips to be used for membrane securement on Mechanically Fastened Roofing Systems.

2.06 Insulation Securement Adhesive

- A. **Flexible FAST Adhesive:** A spray (full coverage) or bead-applied, two-component polyurethane, construction grade, low-rise expanding foam adhesive used for attaching approved insulations to compatible roof decks or existing smooth or gravel surfaced BUR, modified bitumen or cap sheets.
- B. **Flexible FAST Dual Tank:** A two component (Part A and B), extrusion applied, low rise adhesive for bonding insulation to various surfaces. Flexible FAST Dual Tanks utilize an HFO blowing agent. HFO (hydrofluorolefin) blowing agents are widely recognized as the next-generation environmentally friendly blowing agent, replacing their HFC (hydrofluorocarbon) predecessor. When extruded at 12" on center the coverage rate is 3,500 to 3,700 sq.ft. per set of Dual Tanks.
- C. **Flexible FAST Dual Cartridge and 5-gallon Jug Adhesive:** A two component (Part A and B), extrusion applied, low rise adhesive for bonding insulation to various surfaces. When extruded at 12" on center the coverage rate is 400-600 sq.ft. per carton of Dual Cartridges or 2,000-2,500 sq.ft. per set of 5-gallon Jug Adhesive.
- D. **OlyBond 500 Bag in a Box** – A two-component, polyurethane, low-rise expanding adhesive used to bond insulation to various substrates. Packaged in 5-gallon boxes of Part A and Part B formulations that are applied using a mechanical dispenser system. Applied in 1/2" to 3/4" beads or ribbons at the rate of 1 gallon per 150-250 square feet for 12" o.c. bead spacing. Perimeter bead spacing patterns and acceptable insulation and deck types are listed in the applicable Product Data Sheet.
- E. **OlyBond 500 BA Spot Shot** - A two-component, polyurethane construction grade, low-rising expanding adhesive designed for bonding insulation to various substrates. Applied in 1/2" to 3/4" beads or ribbons using a portable 1:1 applicator (oversized, dual-cartridge caulking gun). Refer to the Product Data Sheet for bead spacing with reference to building height.

2.07 Vapor/Air Barrier

A. General

1. The use of a vapor retarder to protect insulation and reduce moisture accumulation within an insulated roofing assembly should be investigated by the specifier, especially on projects with high interior humidity, such as, swimming pools, breweries, pulp mills, etc.

2. If insulation is to be adhered to the vapor retarder with FAST Adhesive, the vapor retarder must be compatible and shall be fully adhered to the substrate. Available products include Carlisle's VapAir Seal 725TR Air and Vapor Barrier, VapAir Seal MD Air and Vapor Barrier and spray or roller applied butyl coatings. Installation requirements for Carlisle's VapAir Seal 725TR Air and Vapor Barrier are identified in **Spec Supplement G-08-20 "Application Procedures for Carlisle's VapAir Seal 725TR Air and Vapor Barrier/Temporary Roof"** and Carlisle's VapAir Seal MD Air and Vapor Barrier are identified in **Spec Supplement G-12-19 "Application Procedures for Carlisle's VapAir Seal MD Air and Barrier"** in the Carlisle Technical Manual.
- B. **Carlisle VapAir Seal 725TR Air and Vapor Barrier** - A 40-mil thick composite consisting of 35-mil self-adhering rubberized asphalt membrane laminated to an 5-mil UV resistant poly film with an anti-skid surface which is fully compatible with FAST Adhesive. 725TR can also function as a temporary roof for up to 120 days. Available in rolls 39" wide by 100' long (325 square feet).
 - C. **Carlisle VapAir Seal MD Air and Vapor Barrier** – a reinforced composite aluminum foil with self-adhesive SBS backing and removable poly release film. Used for direct application over metal decks. Available in rolls 42.5" wide by 131.23' long (460 square feet).
 - D. **CAV-GRIP III Low-VOC Aerosol Contact Adhesive/Primer:** a low-VOC, methylene chloride-free adhesive that can be used for a variety of applications including: enhancing the bond between Carlisle's VapAir Seal 725TR and various substrates. Coverage rate is approximately 2,000-2,500 sq. ft. per #40 cylinder and 4,000-5,000 sq. ft. per #85 cylinder as a primer, in a single-sided application.
 - E. **CCW-702 Primer and 702LV Primer (Low-VOC)** - A single component, solvent based, high-tack primer used to provide maximum adhesion between Carlisle 725TR Air and Vapor Barrier and an approved substrate. Applied by spray or long nap roller with a coverage rating ranging from approximately 300 to 350 square feet per gallon on smooth finishes (i.e., concrete) to 75 square feet per gallon on porous surfaces (i.e., DensDeck Prime gypsum board). Available in 5-gallon containers. CCW-702LV Primer contains less than 250g/L VOCs and meets South Coast Air Quality Management District (SCAQMD) and Leadership in Energy and Environmental Design (LEED®) Requirements for Volatile Organic Compounds.
 - F. **CCW-702WB** – a high-tack, water-based contact adhesive for promoting adhesion of Carlisle air/vapor barrier membranes and an approved substrate (i.e., concrete, DensDeck Prime and Securock). Applied by roller, brush or spray with an application rate of approximately 200 sq. ft. per gallon. Available in 5-gallon containers. CCW-702WB Primer contains 57g/L VOCs and meets South Coast Air Quality Management District (SCAQMD) and Leadership in Energy and Environmental Design (LEED) Requirements for Volatile Organic Compounds.

2.08 Edges and Terminations

A. General

Products listed below can be used with any of the available Carlisle Roofing Systems. Refer to the applicable Carlisle details and installation instruction manuals for specific installation criteria.

B. Products

1. **SecurEdge 200:** A snap-on edge system consisting of a 24 gauge galvanized metal water dam and 40, 50 or 63-mil thick aluminum Kynar 500, clear and colored anodized finish or 22 or 24 gauge steel, Kynar 500® finish. The fascia is available in a variety of colors and heights varying from 5" to 12-½". Custom fascias and colors are available upon request. ANSI/SPRI ES-1 certified.
2. **SecurEdge 2000:** An anchor bar roof edge fascia system consisting of heavy .100" thick extruded aluminum bar, corrosion resistant stainless steel fasteners and snap-on fascia cover used with Adhered, Mechanically Fastened and Ballasted assemblies. Refer to installation instructions for various sizes, colors and accessories ANSI/SPRI ES-1 certified.

3. **SecurEdge 300 Fascia System:** A snap-on edge system consisting of a 24 gauge galvanized metal spring clip water dam and 50 or 63-mil thick aluminum Kynar 500, colored anodized finish or 24 gauge steel, Kynar 500 finish. The fascia is available in a variety of colors and heights varying from 5" to 10". Custom fascias and colors are available upon request. ANSI/SPRI/FM-4435 ES-1 certified.
4. **SecurEdge 300 Coping:** A snap-on coping system that incorporates 20 gauge anchor cleats with pre-slotted holes, a concealed joint cover and 12' continuous sections of coping cap consisting of 40, 50 or 63-mil thick Kynar 500, clear and colored anodized finish or 24 gauge steel, Kynar 500 finish. The coping cap is available in a variety of colors and widths. Custom pieces such as tees, crosses, radius copings, etc., are also available. ANSI/SPRI/FM-4435 ES-1 certified. Also available in **SecurEdge 300 Plus Coping** with 16 gauge anchor cleats for added performance.
5. **SecurEdge 300 Gutter** system incorporates 1" wide extruded internal gutter brackets and aluminum or galvanized steel gutter. Available in 040" (1.00 mm.), or .063" (1.60 mm) aluminum, and 22 gauge or 24 gauge Kynar 500 coated galvanized steel. Gutter support brackets are extruded aluminum. Available in box style, chamfer style, and offset profiles. Engineered to meet ANSI/SPRI GT-1.
6. **SecurEdge 3000:** A metal anchor bar fascia system consisting of a 20 gauge steel retainer bar, corrosion resistant fasteners and an aluminum or 24 gauge steel snap-on fascia cover. It is for use in Fully Adhered and Mechanically Fastened Roofing Systems. ANSI/SPRI ES-1 certified.
7. **SecurEdge 400 Coping:** two-piece assembly that consists of a continuous cleat and a decorative snap-on coping cover. This product features two cleat options: a 22-gauge (G90) pre-punched continuous cleat with fasteners spaced at 12" on center, or a 24-gauge (AZ50) pre-punched continuous cleat with fasteners spaced at 12" on center. SecurEdge 400 Coping is offered in 10' cleat and coping cover lengths.
8. **SecurEdge 400 Spring-Tite Gravel Stop:** is a three-piece assembly that consists of a continuous cleat, spring-stop, and decorative snap-on Gravel Stop cover. This product is available in 10' standard lengths and features a 22-gauge (G90) continuous cleat with pre-punched slotted holes for fasteners at 12" on center. Concealed splice plates and fasteners are included with purchase.
9. **SecurEdge 400 Snap Lock Gravel Stop:** is a two-piece assembly that consists of a continuous cleat and a decorative snap-on Gravel Stop cover. This product features two cleat options: a 22-gauge (G90) pre-punched cleat with fasteners spaced at 12" on center, or a 24-gauge (AZ50) pre-punched cleat with fasteners spaced at 12" on center. SecurEdge 400 Snap Lock Gravel Stop is offered in 10' standard cleat and coping cover lengths.
10. **SecurSeal 200/300/400 Drip Edge:** Designed for use on Adhered and Mechanically Fastened Roofing Systems. Includes a 22 gauge continuous 12' pre-punched 90-degree angle cleat and 10' or 12' long fascia sections. Incorporates concealed joint covers and strong 1-1/4" ring shank nails to provide long-term holding power. A selection of colors in 24 gauge steel, Kynar 500 and 32 or 40-mil aluminum finish or Kynar 500 is available. ANSI/SPRI/FM-4435 ES-1 Certified.
11. **SecurEdge 4000:** A two-piece assembly that includes a continuous cleat and a decorative fascia cover. Available in pre-painted Kynar 500-coated 0.40" formed aluminum and 24-gauge Galvalume steel, this product features 22-gauge pre-punched cleats with fasteners spaced at 12" on center. ANSI/SPRI ES-1 certified.
12. **Sure-Seal Ballast Retaining Bar:** A ballast retaining perimeter securement system comprised of a slotted (4" on center) extruded mil aluminum retention bar with an integrated compression fastening strip. 1-1/2" stainless steel fasteners with Neoprene washers are provided for stable securement.

13. **Termination Bar:** A 1" wide and 98-mil thick extruded aluminum bar pre-punched 6" on center which incorporates a sealant ledge to support Lap Sealant and provide increased stability for membrane terminations.
14. **SecurEdge Term Bar Fascia:** A 1.75" wide formed aluminum termination bar with pre-slotted fastening holes for ease of locating and installing. The decorative cover is available in 0.040" aluminum or 24-gauge galvanized steel. SecurEdge Term Bar Fascia is manufactured in 12' lengths for fewer joints/seams, fewer sections to handle and faster installation.
15. **Other Carlisle Metal Edgings / Copings** suitable for use with roofing system included in the section, can be found in the Specification Supplement G-11-18 Metal Edging.

2.09 Roof Walkways

Walkways are to be specified at all traffic concentration points (i.e., roof hatches, access doors, rooftop ladders, etc.), and if regular maintenance, once a month or more, is necessary to service rooftop equipment.

A. Walkway types:

1. **Sure-Seal/Sure-White Pressure-Sensitive Walkway Pads:** Sure-Seal (black) or Sure-White (white) molded walkway pads with Pressure-Sensitive TAPE used to provide protection for areas of EPDM membrane that are exposed to regular rooftop maintenance.
2. **Sure-Seal Interlocking™ Rubber Pavers:** 24" X 24" X 2" thick rubber paver weighing approximately 24 pounds per unit, 6 pounds per square foot manufactured from recycled rubber, which provides a resilient, shock absorbing, weather resistant surface. Designed primarily for use as a walkway or on terrace areas offering a unique, environmentally sound advantage over concrete pavers. Features include freeze/thaw stability, bi-directional drainage and no breakage concerns. Available in black and terra cotta.
3. **Hanover Ballast and Lightweight Ballast Pavers:** The standard, 24" x 24" x 1-13/16" thick, Ballast Paver comes in a natural color and a non-slip Diamond finish and weighs 22 lbs/sq. ft. The Lightweight, 23-1/2" x 23-1/2" x 1-1/4" thick, Ballast Paver comes in a natural color and a non-slip diamond finish and weighs 15 lbs/sq. ft. Both pavers can be used as ballast or walkways.

2.10 Other Carlisle Accessories

Refer to Spec Supplement P-01-20 "Related Products" for additional accessories.

Part III – EXECUTION

Prior to commencing with the installation of any of the EPDM Membrane Systems refer to Paragraph 1.05 “Warranty Tables” for applicable components and proper securement method suitable for the appropriate warranty coverage.

Requirements listed in this specification are considered minimum and are intended for the sole purpose of obtaining a Carlisle Warranty. Additional requirements dictated by Regulatory Agencies, Building Insurance or Specifiers must be complied with and are considered to be beyond the scope of this specification.

3.01 General

- A. Safety Data Sheets (SDS) must be on location at all times during transportation, storage and application of materials. The applicator shall follow all safety regulations as recommended by OSHA and other agencies having jurisdiction.
- B. Subject to project conditions, it is recommended to begin the application of this roofing system at the highest point of the project area and work to the lowest point to prevent water infiltration. This will include completion of all flashings, terminations and daily seals.
- C. A proper substrate shall be provided by the building owner. The structure shall be sufficient to withstand normal construction loads and live loads.

3.02 Roof Deck/Substrate Criteria

- A. Proper decking shall be provided by the building owner. The building owner or their designated representative must ensure that the building structure is investigated by a registered engineer to assure its ability to withstand the total weight of the specified roofing system, as well as construction loads and live loads, in accordance with all applicable codes. The specifier must also designate the maximum allowable weight and location for material loading and storage on the roof.
- B. When insulation is mechanically fastened to the roof deck, withdrawal resistance tests are strongly suggested to determine the suitability of the roof deck. Refer to **Design Reference DR-06-19 “Withdrawal Resistance Criteria”** in the Carlisle Technical Manual proper procedures for conducting pullout tests.
- C. Defects in the substrate surface must be reported and documented to the specifier, general contractor and building owner for assessment. The Carlisle Authorized Roofing Applicator shall not proceed with installation unless defects are corrected.
- D. On structural concrete decks, when a vapor retarder is not used, gaps in the deck along the perimeter and around penetrations must be sealed along with vertical joints between tilt-up panels, if present, to prevent infiltration of hot humid air and possible moisture contamination resulting from condensation. This is specifically important when polyurethane adhesive is used to attach the roof insulation.
- E. **For all projects** (new or retrofit), the substrate must be relatively even without noticeable high spots or depressions. Accumulated water, ice or snow must be removed to prevent the absorption of moisture in the new roofing components and roofing system.
- F. Prior to the placement of membrane underlayment, clear the substrate of debris and foreign material that may be harmful to the roofing system. Gaps greater than ¼" must be filled with an appropriate material.
- G. For direct application over an acceptable roof deck/substrate or when HP Protective Mat is specified and approved by Carlisle as the membrane underlayment in accordance with the Roof Deck and Substrate Criteria Table, the substrate must be smooth, steel trowel finished (structural concrete), free of debris, protrusions, sharp edges and loose and foreign material. Cracks or voids in the substrate, greater than ¼", must be filled with an appropriate material.

- H. **On retrofit - recover projects**, cut and remove wet insulation, as identified by the specifier, and fill all voids with new insulation of type specified so it is relatively flush (+/- 1/4") with the existing surface.
1. Entrapment of water between the old and new membrane can damage and deteriorate new insulation/underlayment between the two membranes. **If a vapor retarder or air barrier is not specified**, Carlisle recommends the existing membrane be perforated to avoid potential moisture accumulation and to allow the detection of moisture to enable the building owner to take corrective action. This can be accomplished by drilling approximately 3/4" diameter holes every 100 square feet in the existing built-up roof or single-ply membrane (excluding PVC membrane).
 2. **For existing PVC membranes**, if the membrane is not removed, it must be cut into maximum 10' by 10' sections. All PVC flashings at the perimeter, roof drains and roof penetrations must be removed.
 3. When installing this roofing system over an existing **gravel surfaced built-up roof, loose gravel must be removed**. Power brooming is recommended by Carlisle to remove the loose gravel, which may trap moisture. Any uneven areas of the substrate must be leveled to prevent insulation from bridging.
 4. On retrofit projects, all existing phenolic insulation must be removed.
 5. Refer to table below for other Recover/Retro-fit considerations.
- I. The following table identifies the **acceptable roof decks/substrates** and the **minimum underlayment** requirements for Carlisle's EPDM Roofing Systems.

NOTE: Refer to the Warranty Tables, Paragraph 1.05, of this specification, for the minimum underlayment requirements for a specific Warranty Coverage.

Roof Deck & Substrate Criteria

Certain warranty restrictions apply for projects with warranties greater than 15 YR. Refer to Table V "Re-Roofing Substrate Criteria" for warranty limitations in paragraph 1.05.

Acceptable Roof Deck/Substrate	EPDM Membrane		
	Adhered - Design "A"	Ballasted - Design "B"	Mechanically Fastened
NEW CONSTRUCTION			
Steel (min. 22 gauge) (1)(2)	Insulation	Insulation	Insulation
Structural Concrete (min. 3000 psi)	Direct Application (11)	Insulation	HP Protective Mat (10)
Plywood (min. 15/32" thick) or Oriented Strand Board (min. 7/16" thick)	Direct Application (11)	Insulation	Direct Application (11)
Wood Planks (minimum 3/4" thick)	Direct Application	Insulation	Direct Application (11)
Fibrous Cement	Insulation	Insulation	HP Protective Mat
Lightweight Insulating Concrete	Note 3 (10)	HP Protective Mat (10)	Direct Application (10)
RETROFIT / NO TEAR-OFF	Adhered - Design "A"	Ballasted - Design "B"	Mechanically Fastened
Existing Smooth Surface BUR or Mineral Surface Cap Sheet	Direct Application (4) (11)	Insulation	Direct Application (4) (11)
Gravel Surfaced BUR (5)	Insulation	Insulation	Insulation
Coal Tar Pitch (5)(6)	Insulation (9)	Insulation	Insulation
Modified Bitumen	Direct Application (8) (11)	Insulation	Direct Application (8) (11)
Existing Single-Ply	Insulation	Insulation (7)	Direct Application (7) (11)
Sprayed-in-place Urethane	Complete Tear-off Required	Insulation	Complete Tear-off Required
RETROFIT / TEAR-OFF	Adhered - Design "A"	Ballasted - Design "B"	Mechanically Fastened
Existing roof material removed (regardless of deck type)	Insulation	Insulation	Insulation

Notes:

- (1) Local codes must be consulted regarding thermal barrier requirements.
- (2) Mechanically Fastened Systems cannot be specified on steel decks less than 22 gauge or for corrugated steel decks, regardless of gauge.
- (3) The Design "A" Adhered Roofing System may be specified directly over a new approved cellular or perlite lightweight insulating concrete substrate with a minimum compressive strength of 225 psi. Except when the lightweight insulating concrete is poured over slotted steel decks, pressure relief vents must be specified at a minimum rate of 1 every 2000 square feet. Direct Application is not permitted where the lightweight concrete is poured over an existing roofing material. Refer to **Spec Supplement G-04-20 "Adhered Application Over Lightweight Insulating Concrete"**.
- (4) Sure-Seal (black) Adhered and Mechanically Fastened Systems may be applied directly to the substrate provided asphalt on existing smooth surfaced built-up roof has a softening point above 185°F (85°C). Sure-White (white-on-black) Roofing Systems are not recommended for direct application to the substrate due to possible staining of the membrane surface. For direct application over smooth BUR or granule surface BUR or in conjunction with HP Mat make sure substrate is clean and free of roofing cement and fresh asphalt to avoid sheet contamination and staining of white color membrane.
- (5) Loose gravel must be removed to avoid entrapment moisture.
- (6) Existing coal tar could drip back into the building, especially when new insulation does not provide sufficient thermal value to prevent the surface of the coal tar from softening.
- (7) An approved insulation/underlayment is required over existing ballasted single-ply systems and PVC roofing systems of any type.
- (8) Direct application permitted over smooth surfaced modified bitumen. Membrane shall be positioned with length of sheets parallel to modified bitumen field seams. At end laps or other locations where EPDM splices intersect modified bitumen field seams, 6" wide Elastoflor or Pressure-Sensitive Flashing must be applied over intersections.
- (9) If insulation is specified to be secured to an existing coal tar pitch roof with Carlisle FAST Adhesive or hot asphalt, minimum 1.5" thick Polyisocyanurate insulation is the required minimum thickness when Sure-Seal (black) EPDM is specified. Minimum 1" thick Polyisocyanurate is the required minimum thickness when Sure-White (white) EPDM is specified.
- (10) For direct application, membrane system warranties are limited to 15 YR unless specifically approved by Carlisle.
- (11) Maximum warranty available is 20 YR with 55 MPH warranty wind speed (72 MPH warranty wind speed over structural concrete, wood planks or plywood) Peak gust wind speed coverage. Carlisle may be contacted for other options.

J. Vapor Retarder Installation

For Carlisle's Vapor Retarder refer to **Spec Supplement G-08-20 "Application Procedures for 725TR Air and Vapor Barrier"**. Follow the respective vapor retarder manufacturer's recommended installation procedures and the specifier's instructions for the installation of the product specified. When insulation is to be set in adhesive, verify compatibility with Carlisle when Vapor Retarder by others is specified.

K. Wood Nailers

1. Install wood nailers in locations that have been designated by the specifier and as approved by Carlisle. Refer to **Design Reference DR-08-11 "Wood Nailers and Securement Criteria"** for Wood Nailer Criteria.
2. Wood nailers are not covered by the Carlisle Warranty.

3.03 Insulation/Underlayment

A. General

1. Roof insulation thickness must be determined by the thermal value required for each project and may be subject to code approval limitations. On projects where a vapor retarder is used, the specifier must calculate insulation thickness to ensure the temperature at the vapor retarder will not fall below the dew point.
2. For new construction projects in cold climate regions, the use of vapor retarders or air barriers is strongly recommended to protect insulation from moisture generated during construction.
3. Multiple layers of insulation are recommended with all joints staggered between layers.
4. Do not install more insulation/underlayment than can be covered by membrane in the same day.
5. All insulation boards must be butted together with no gaps greater than 1/4". Gaps greater than 1/4" are not acceptable.
6. Restrictions:
 - a. Carlisle Roofing Systems cannot be specified in conjunction with Phenolic Insulation.
 - b. Fiberglass insulation cannot be specified with Carlisle's Design "A" Adhered and Mechanically Fastened Roofing Systems, even if overlaid with additional insulation or membrane underlayment.
 - c. Do not specify perlite boards directly under the EPDM membrane on Design "A" Adhered or Mechanically Fastened Roofing Systems.
 - d. Wood fiberboard manufactured by others is not an acceptable underlayment for use with Design "A" Adhered Roofing Systems unless approved in writing by Carlisle prior to installation.
 - e. For all EPDM Roofing Assemblies, the use of insulation by others is not acceptable when a Carlisle Membrane System Warranty is specified. Carlisle insulation must be used.

3.04 Insulation Attachment

A. General

1. Prior to proceeding with insulation securement refer to Warranty Tables, Paragraph 1.05, for attachment method and appropriate fastening density required for the specific Carlisle Warranty.

B. Adhered Roofing Systems

1. **Mechanical Attachment**, insulation fastening density will vary based on insulation type, thickness, and required warranty. Warranty Tables in Paragraph 1.05 should be referenced for fastening density and the appropriate Carlisle detail may be consulted to identify acceptable fastening pattern.

- a. For code compliance, increased fastening density may be required depending upon project wind speed and wind uplift requirement. Refer to Design Reference **DR-05-19 “Insulation Fastening Patterns”** for fastening pattern reference.
 - b. When insulation securement is to comply with Factory Mutual (FM) approvals, follow the requirements of the specifier concerning additional securement at the roof perimeter and corners. Also refer to Design Reference DR-05-21 “Insulation Fastening Patterns” for various fastening patterns.
 - c. On Reroof/No Tear off projects with a maximum roof height of 40', any Carlisle Insulation (i.e., ½" SecurShield HD, HP Recovery Board, Polyisocyanurate less than 1-½" thick) may be secured at the minimum rate of 11 Fasteners per 4' x 8' board (5 Fasteners per 4' x 4' board).
 - d. When Oriented strand board (OSB) is specified for membrane underlayment, utilize StormBase OSB/Polyiso Composite, mechanically fastened to the deck at the rate 17 fasteners for 4 x 8 board in accordance with Carlisle Details. When positioning OSB, butt edges and stagger joints of adjacent panels.
2. **Adhesive attachment**, Carlisle Urethane Adhesive Full Spray (Flexible FAST) or Bead (Flexible FAST or Olybond) may be used. When bead adhesive is specified bead spacing will vary based on Warranty coverage, refer to Warranty Tables, Paragraph 1.05 and appropriate Carlisle Details. **CAUTION:** Apply adhesive bead so that the distance from the edge of the board does not exceed half the bead spacing (i.e. within 6" of bead spacing of 12" O.C.).
- a. **CAUTION: Do not apply urethane adhesives directly to un-weathered asphalt, (new or residual).**
 - b. **CAUTION: Especially in cold regions on tear-off projects or new construction gaps between horizontal and vertical surfaces of the roof area as well as gaps around penetrations must be sealed to prevent interior warm air from infiltrating and condensing within the roofing assembly. Condensing moisture could weaken bottom insulation facer and eventually result in dislodgement or loose boards when adhesive is used.**
 - c. On FM Global insured projects, consult FM Global's local representative concerning the use of adhesive to attach insulation to steel decks.
 - d. Check to ensure the substrate is clean, free of debris, other contaminants, and dry. Adhesive cannot be applied to a wet or a damp surface.
 - e. Apply Adhesive over the dry substrate area at the coverage rates indicated in **Spec Supplement G-03-22 “Insulation Attachment with Flexible FAST Adhesive”**.
 - f. Allow the adhesive to rise up approximately ¼" to ¾", depending on dispensing method, and develop strings prior to setting insulation boards into adhesive.

NOTE: String-time is measured by touching the adhesive with a splice wipe and looking for development of “strings” of adhesive as you pull the splice wipe out of the adhesive. With Flexible FAST Adhesive, string time is generally around 1-½ – 2 minutes after application at room temperature.
 - g. **Walk the boards into the adhesive and roll using the 30" wide, 150 pound segmented steel roller** to ensure full embedment. Optimal set up time should be approximately 5 to 7 minutes.

CAUTION: Walking on the boards immediately after placement in adhesive can cause slippage/movement until the adhesive has started to set up.

CAUTION: If the boards easily slide, string time has not been achieved.

On roofs with a slope greater than $\frac{1}{2}$ " in 12", begin adhering insulation at the low point and work upward to avoid slippage.

One person should be designated to walk/roll in all boards. Relief cuts may be necessary to allow lifted board to lay flat, or constant weight (a minimum 10 lbs for 5-15 minutes per lifted area) may be necessary to achieve adequate adhesion.

- h. Refer to **Spec Supplement Spec Supplement G-02-22 "Flexible FAST Adhesive Equipment and Set-Up Requirements"** and **G-03-22 "Insulation Attachment with Flexible FAST Adhesive"** for application procedures and coverage rates.
3. **Alternate attachment method**, the specifier may select an alternate insulation attachment that incorporates a solid mopping of the insulation with hot asphalt (ASTM D312, Type III or IV). If the attachment method is to be covered by the Carlisle Warranty, Carlisle must be contacted for specific requirements. Upon review and acceptance by Carlisle, the maximum warranty coverage available is limited to 20 Year with maximum Peak Gust Wind Speed Coverage of 72 mph.
- a. Extruded or Expanded Polystyrene insulation are not acceptable when this alternate attachment method is specified.
 - b. The existing gravel surfaced built-up roof must be scraped to remove all loose gravel. Large blisters that may prevent continuous embedment of insulation must be repaired. The surface of the substrate must also be dry and clear of foreign material.
 - c. On coal tar pitch, when deemed compatible by the specifier, minimum 1.5" Polyisocyanurate is the required membrane underlayment when using Sure-Seal (black) membrane. If Sure-White (white) membrane is used, minimum 1" thick Polyisocyanurate is required.
 - d. For successful attachment, proper asphalt temperatures must be maintained and the specifier's requirements concerning the installation of a base sheet (where required) and quantity of hot asphalt must be followed.
 - e. The maximum insulation board size shall not exceed 4' X 4'. Trim insulation boards around crickets and saddles to ensure continuous embedment.
 - f. Care must be exercised to prevent contamination of the top surface of the insulation. Asphalt oozing through insulation joints must be wiped from the surface. Contact with fresh asphalt can result in discoloration of the Sure-White membrane.
 - g. Use of grid nailer, subdividing the roof into individual sections of 2400 square feet, is not required, but its use is strongly recommended.
 - h. The wood nailers are installed relatively flush with the insulation surface and the membrane is to be fastened with seam fastening plates and Carlisle HP fasteners on 12" o.c. For wood nailer installation, refer to Design Reference **DR-08-11 "Wood Nailers and Securement Criteria"**.

C. Ballasted Roofing Systems

1. Insulation boards shall be loose laid over the substrate.

NOTE: If insulation securement is specified, only Carlisle approved insulation adhesive may be used. Mechanical securement of roof insulation is not permitted due to increased probability of membrane puncture during ballast installation or periodic rooftop maintenance.

2. Refer to Roof Deck/Substrate Criteria in Paragraph 3.02 for further information.

NOTE: The use of cover boards, such as SecurShield HD, SecurShield HD Plus, DensDeck or DensDeck Prime or DensDeck StormX Prime or Securock, is not permitted in conjunction with Ballasted Assemblies to reduce possible membrane punctures. Hard cover boards do not provide sufficient cushioning beneath the membrane and therefore when the assembly is subjected to traffic, the membrane is subjected to higher point loading resulting in puncture.

D. Mechanically Fastened Roofing Systems

1. **Carlisle Fasteners and Fastening Plates are required for insulation securement.** Refer to Insulation Fastening Criteria Table in Paragraph 2.05, for appropriate fastener and deck penetration. The fastener can be used with either 2" diameter Sure-Seal Seam Fastening Plates or 3" diameter Sure-Seal Insulation Fastening plate.
2. **Any Carlisle approved insulation or cover board** shall be mechanically fastened to the roof deck at the minimum rate of **1 fastener and plate per every 8 square feet** (4 fasteners in a 4 x 8 board) for warranties up to 15 year. Projects with up to 20 year or greater warranties (with standard wind speed coverage) require the use of 6 fasteners and plates in a 4' x 8' board (1 per 5.333 square feet).

CAUTION: Sure-Seal Polyisocyanurate Insulation with a thickness less than 1.5" installed over an existing roofing membrane without a tear-off must be mechanically fastened to the roof deck with a minimum of **1 fastener and plate for every 4 square feet** or less of insulation.

3. Use of DensDeck, DensDeck Prime and DensDeck StormX Prime should be limited to assemblies with slopes greater than 2" per foot to ensure compliance with external fire codes, care shall be exercised to ensure polymer seam plates are fully seated.

3.05 Membrane Placement and Securement

A. General

1. **Ensure** that water does not flow beneath any completed sections of the membrane system by completing all flashings, terminations and daily seals by the end of each workday.
2. **Sweep** all loose debris from the substrate.
3. If aesthetics are of concern when Sure-White EPDM is to be used, protection should be specified to avoid discoloration of the white membrane surface resulting from adhesive residue or excess foot traffic.
4. Adjoining sheets of EPDM membrane are spliced together using SecurTAPE and Primer.
5. In addition to the primary membrane securement (Bonding for Adhered, Ballasting for Ballasted Systems and Fastening for Mechanically Fastened assemblies), additional membrane securement is required at the perimeter of each roof level, roof section, curb, skylight, interior wall, penthouse, etc., at any inside angle change where slope or combined slopes exceed 2" in one horizontal foot, and at other penetrations in accordance with the applicable Carlisle details. Refer to Paragraph G for additional membrane securement.

B. Membrane Placement

EPDM membrane with factory applied tape is available in various widths. Prior to unrolling sheets ensure the tape side is properly located so that seams are properly shingled down slope. (Pre-applied SecurTAPE should always be facing downwards once the sheet is unrolled).

1. **Position** EPDM membrane over the acceptable substrate without stretching. For mechanically fastened assemblies ensure proper number of perimeter sheets are properly positioned along the perimeter of the roof. And field sheets are positioned perpendicular to the steel deck flutes.
2. **Allow** the membrane to relax approximately ½ hour prior to splicing (Ballasted systems), bonding (Adhered Systems) or fastening (Mechanically Fastened).
3. **Place** adjoining membrane sheets in the same manner, overlapping edges appropriately to provide for the minimum splice width (2-½" or 5-½" depending on warranty duration). It is recommended all splices be shingled to avoid bucking of water.

C. **Membrane Securement / Bonding - Adhered Roofing Systems (90-8-30A, EPDM x-23 LVOC, Low-VOC Bonding Adhesive or Aqua Base 120)**

1. **Adhere** EPDM membrane to an acceptable substrate with Carlisle Bonding Adhesive. Comply with Labels, Safety Data Sheet (SDS) and Product Data Sheets for installation procedures and use. Contact type bonding adhesive must be applied to both the membrane and the surface to which it is being bonded.
2. On projects at high altitudes (6,000' and above), rapid flash-off (drying) of Bonding Adhesive and Primers will occur due to low atmospheric pressure.
3. **Fold** membrane sheet back so approximately half of the underside of the sheet is exposed. Sheet fold should be smooth without wrinkles or buckles.
4. **Stir** Bonding Adhesive thoroughly scraping the sides and the bottom of the can (minimum 5 minutes stirring is recommended). Bonding surfaces must be dry and clean.

CAUTION: If aesthetics are of concern when Sure-White EPDM membrane is used, protect the white surface next to the edges of the folded membrane sheet so Bonding Adhesive will not discolor the white surface. Do not place Bonding Adhesive containers or their lids directly on the white surface of the Sure-White EPDM membrane.

5. **Apply** Bonding Adhesive evenly, without globs or puddles, with a plastic core medium nap paint roller. A 9" roller will easily fit into the 5-gallon containers.

Apply contact type bonding adhesive to both the membrane sheet and the substrate to achieve continuous coating of both surfaces at a coverage rate of approximately 120 square feet per gallon per one surface (membrane or substrate) or approximately 60 square feet per gallon per finished surface (includes coverage on both membrane and substrate). **Depending on adhesive used and the substrate type adhesive coverage rate will vary.** Refer to Product Data Sheets for the appropriate adhesive for the proper coverage rate.

A mechanical roller dispenser or a mechanical sprayer can be used to apply Bonding Adhesive when the continuous coating and coverage rate noted above are maintained. When used, **the adhesive must be rolled after applying** with a plastic core medium nap paint roller to provide continuous coverage.

CAUTION: Due to solvent flash-off, condensation may form on freshly applied Bonding Adhesive when the ambient temperature is near the dew point. If condensation develops, possible surface contamination may occur and the application of Bonding Adhesive must be discontinued. Allow the surface to dry and apply a thin freshener coat at the coverage rate, which is approximately half of the coverage rate stated above to the previously coated surface when conditions allow for continuing.

6. **Allow** adhesive to flash-off until it is tacky but will not string or transfer to a dry finger touch.
7. **Roll** the coated membrane into the coated substrate while avoiding wrinkles.
8. **Brush** down the bonded half of the membrane sheet, immediately after rolling the membrane sheet into the adhesive, **with a soft bristle push broom** to achieve maximum contact.
9. **Fold** back the unbonded half of the membrane sheet and repeat the bonding procedure.

D. **Membrane Securement / Bonding - Adhered Roofing Systems (CAV-GRIP III)**

1. **Adhere** EPDM membrane to an acceptable substrate with CAV-GRIP III Bonding Adhesive. Comply with Labels, Safety Data Sheet (SDS) and Product Data Sheets for installation procedures and use. Contact type bonding adhesive must be applied to both the membrane and the surface to which it is being bonded.
2. On projects at high altitudes (6,000' and above), rapid flash-off (drying) of Bonding Adhesive and Primers will occur due to low atmospheric pressure.

3. **Fold** membrane sheet back so approximately half of the underside of the sheet is exposed. Sheet fold should be smooth without wrinkles or buckles.
4. **Connect CAV-GRIP III Cylinder** with hose and spray gun. Bonding surfaces must be dry and clean.

CAUTION: If aesthetics are of concern when Sure-White EPDM membrane is used, protect the white surface next to the edges of the folded membrane sheet so Bonding Adhesive will not discolor the white surface. Do not place CAV-GRIP III Cylinders directly on the white surface of the Sure-White EPDM membrane.
5. **Spray apply CAV-GRIP III Bonding Adhesive** evenly to both the membrane and substrate with a minimum 2" overlap to ensure 100% coverage. Avoid heavy areas or puddles that can skin over, trap solvent and create a blister. Refer to Product Data Sheets for the proper coverage rate.

CAUTION: Solvent flash-off can lower surface temperature below the dew point causing moisture to form on the adhesive. Slide your hand across the flashed-off adhesive on the insulation or cover board to ensure moisture has evaporated and the adhesive surface is dry and tacky prior to installing the membrane.
6. **Allow** adhesive to flash-off, especially the heavy areas of adhesive, until it is tacky but will not string or transfer to a dry finger touch.
7. **Roll** the coated membrane into the coated substrate while avoiding wrinkles.
8. **Brush** down the bonded half of the membrane sheet, immediately after rolling the membrane sheet into the adhesive, **with a soft bristle push broom.**
9. **Roll the membrane with a 150 lb weighted segmented steel roller after brooming to achieve maximum contact.**
10. **Fold** back the unbonded half of the membrane sheet and repeat the bonding procedure.

E. **Membrane Securement / Ballasting - Ballasted Roofing Systems**

1. Ballasting - General
 - a. Use of temporary ballast to prevent wind uplift is the responsibility of the Carlisle Authorized Roofing Applicator. For immediate protection against wind uplift, Carlisle requires ballast to be installed as each section of the installation is completed.
 - b. When using polystyrene insulation directly beneath the membrane, ballast must be applied immediately after membrane installation to prevent potential damage to polystyrene insulation products from excessive heat.
 - c. Care must be exercised during application of gravel or pavers. Heavily traveled areas during ballast installation must be protected by placing temporary protection courses to prevent possible damage to the EPDM deck membrane and insulation.
2. Ballast Types/Coverage Rates
 - a. The coverage rates listed in this section are considered minimum and are required by Carlisle for issuance of the standard Carlisle warranty. Depending on specific project conditions (building height, parapet height and project location), additional ballast may be necessary to provide wind uplift protection. Refer to "Attachment I" at the end of this section for suitable ballast types and coverage rates. **Comply with the specifier's requirements when an additional ballast coverage rate is specified.**
 - b. **Rounded Water-Worn Gravel** must be applied over the EPDM membrane at the minimum rate of **1000 pounds per square** and must be evenly distributed to maintain an average of 10 pounds per square foot.

ASTM D 7765 SIZE NUMBER	MINIMUM COVERAGE RATE (pounds per square)	AVERAGE COVERAGE RATE (lbs./sq. ft. continuously distributed)
4 (1-1/2" nominal diameter)	1000	10
3 (2" nominal diameter)	1000	10
2 (2-1/2" nominal diameter)	1300	13
1 (3-1/2" nominal diameter)	1300	13

NOTES: In the field of the roof, some bare spots resulting from installation are permitted; however, they must not exceed 64 square inches and must be limited to no more than 2 per square (100 square feet). No bare spots are permitted in the perimeter area of the roof that is 10' wide.

- c. **Crushed Stone** must be applied in conjunction with Sure-Seal HP Protective Mat placed over the EPDM membrane. The crushed stone must be applied at the minimum rate of **1000 pounds per square** and must be evenly distributed to maintain an average of 10 pounds per square foot.
- d. **Smooth Surfaced Individual Concrete Pavers or Lightweight Interlocking Concrete Pavers**
 - i. Lightweight interlocking pavers and individual concrete pavers with a surface other than steel troweled finish must be installed over Sure-Seal HP Protective Mat. Contact Carlisle for verification of acceptable pavers.
 - ii. **Individual Concrete Pavers**, when specified, must be installed loose laid and butted with no gaps greater than 1/2".

NOTE: Do not install pavers heavier than 100 pounds per unit unless approved in writing by Carlisle.

- iii. **Lightweight Interlocking Concrete Pavers**, when specified, must be installed in accordance with the respective manufacturer's specification and as approved by Carlisle prior to installation.

3. Ballast Criteria for Up to 20 Year Extended Warranty

- a. Refer to installations below for calculating corner/perimeter areas for the noted warranty wind speeds available.

Ballast Requirements for 72 mph Warranty

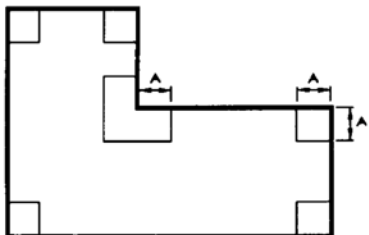

A (Corners) = .4 Times the Building Height
(10' minimum)

Ballast Requirements for 80 mph Warranty

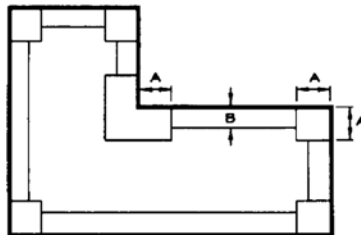

A (Corners) = .4 Times the Building Height
(10' minimum)
B (Perimeters) = 10'

- b. At corner and/or perimeter areas, ballast shall be 2-½" nominal rounded water worn gravel conforming to gradation #1 or #2 in accordance with ASTM -D7765 method of sizing. Coverage rate shall be a minimum of 13 pounds per square foot.
 - c. In field areas, ballast shall be 1-½" nominal rounded water worn gravel conforming to gradation #4 in accordance with ASTM-D7765 method of sizing. Coverage rate shall be a minimum of 10 pounds per square foot.
4. Placement of Sure-Seal HP Protective Mat
- a. When specified or required by Carlisle, position Sure-Seal HP Protective Mat loosely over the membrane with all edges overlapped a minimum of 6".
 - b. Extend the mat a minimum of 2" above the anticipated ballast level at the perimeter and around penetrations except for roof drains and scuppers.
 - c. The mat must extend to drain bases, scupper openings and the base of Dutch gutters but **must not restrict drainage**.
 - d. Additional matting must be installed around penetrations to prevent direct contact between crushed stone or pavers and flashing.

NOTE: Following the placement of the HP Protective Mat, it is necessary to install the ballast or temporary ballast to prevent the movement or displacement of unballasted fabric.

F. Membrane Securement / Mechanically Fastened Roofing Systems (Fastening)

- 1. EPDM membrane shall be mechanically attached to the structural deck with specified Carlisle Fasteners and designated Plates or Bars, for fastening densities and numbers of perimeter sheets refer to Warranty Tables, Paragraph 1.05.
- 2. Membrane Fastening Selection Table

Membrane Fastener Selection

Deck Type	Carlisle Fasteners*	Carlisle Plate
Steel or Lightweight Insulating Concrete over Steel	HP	HP Polymer or Seam Fastening Plates**
	HP-Xtra	HP-Xtra Polymer
Structural Concrete, rated 3,000 psi or greater	CD-10	HP Polymer or Seam Fastening Plates
	HD 14-10	HP Polymer or Seam Fastening Plates
Wood Plank, min. 15/32" thick Plywood or min. 7/16" OSB	HP	HP Polymer or Seam Fastening Plates
Cementitious Wood Fiber Gypsum	Polymer Gyptec	Gyptec Plates – 2" Dia.
	Polymer Gyptec	Gyptec Plates – 2" Dia.

Refer to Warranty Tables in Paragraph 1.05 for fastening densities and number of perimeter sheets.

*Determine proper fastener length for deck penetration, refer to Table 2.05B.

**Seam Fastening Plates for Base of Wall Angle Change Only

- 3. On steel decks, membrane shall be positioned with seams perpendicular to the steel deck flutes. This allows the external forces on the roof assembly to be distributed between multiple steel deck panels. Refer to Design Reference **DR-06-19 "Withdrawal Resistance Criteria"**.
- 4. When mechanical securement is not provided in some of the Carlisle Universal Details (i.e., pipes and pourable sealer pockets), additional Seam Fastening Plates must be used for membrane securement. The plates must be positioned a maximum of 12" away from the penetration, spaced a maximum of 12" on center and flashed in accordance with the applicable Carlisle Detail.
- 5. **Perimeter Sheets**

The number of perimeter sheets and fastener spacing is dependent on the building height, wind zone location and warranty duration as outlined in Warranty Tables in Paragraph 1.05.

The roof perimeter is defined as all edges of each roof section (i.e., parapets, building expansion joints at adjoining walls, penthouse walls, etc.). When multi-level roofs meet at a common wall, the adjacent edge of the upper roof is treated as a roof perimeter if the difference in height is greater than 10'. Perimeter sheets are not required at the base of the wall at the lower level.

NOTE: Expansion joints, control joints and fire walls in the field of the roof or roof ridges with slopes less than 3" to the horizontal foot are not considered as part of the roof perimeter.

Perimeter sheets can be formed by using individual 5', 6.5' wide sheets or by sub-dividing 8' or 10' wide field sheet using 9" Pressure-Sensitive RUSS strip or row of seam fastening plates as described below.

a. **Individual perimeter sheets (5', 6.5')**

Position membrane along the perimeter of the roof over the acceptable insulation/ underlayment. The perimeter membrane width from line of securement to line of securement should be approximately 4.5' – 6.0' wide depending on perimeter sheet size.

b. **RUSS (Reinforced Universal Securement Strip) Method**

- i. When **field sheets are positioned parallel to a roof perimeter, 9" wide Pressure-Sensitive RUSS** shall be placed approximately down the center of the 8' or 10' wide field membrane sheets. When a RUSS divides a field sheet in half, two perimeter sheets are created.
- ii. When a 8' or 10' wide reinforced **EPDM membrane sheet extends perpendicular to the edge of the roof**, install **9" wide Pressure-Sensitive RUSS** beneath the EPDM membrane sheet approximately of 3'-6" for the 8' field sheet to approximately of 4' -0" for the 10' field sheet from the edge of the roof. When multiple perimeter sheets are required, additional RUSS may be positioned approximately 3'-6" to 4'-0" from the previous RUSS to create additional perimeter sheets.

CAUTION: 6" wide Pressure-Sensitive RUSS is only available with 3" wide SecurTAPE on one side and therefore cannot be used to form perimeter sheets.

- iii. Refer to Applicable Carlisle Details for installation.

c. **Fastening Plates Method (When Option a and b are not feasible)**

When field sheets extend to the edge of the roof, approved fastening plates can be installed through the reinforced membrane 3'-6" to 4'-6" from the roof edge which will be flashed with 6" wide Pressure-Sensitive Cured Cover Strip. When field sheets are positioned parallel to the roof edge, fastening through the membrane along the centerline creates two perimeter sheets. When multiple perimeter sheets are required, additional fastening plates shall be positioned 3'-6" to 4'-6" from the previously installed fastening plates. Refer to applicable Carlisle Details for installation.

d. **Building with Special Conditions:**

Air pressurized buildings, canopies and buildings with large openings where the total wall openings exceed 10% of the total wall area on which the openings are located (such as airport hangars, warehouses and large maintenance facilities) will typically require additional perimeter membrane securement, an increased fastening density or other enhancement.

e. **Buildings with large openings**

When any wall contains major openings with a combined area which exceeds 10% of the total wall area on which the openings are located, either four 5' or 6.5' wide or two 10' wide reinforced EPDM membrane sheets (centered over the opening) must be specified as shown.

- i. 9" wide Pressure-Sensitive RUSS (Reinforced Universal Securement Strip) shall be specified in conjunction with the 8' or 10' wide membrane sheets.

- ii. The 9" wide Pressure-Sensitive RUSS is to be positioned beneath the 8' or 10' wide membrane sheet along the centerline and shall be secured with Polymer Seam Plates (required for steel decks) or Seam Fastening Plates. All fasteners and plates shall be spaced at the rate required at the roof perimeter as shown on the membrane securement charts on the previous pages.

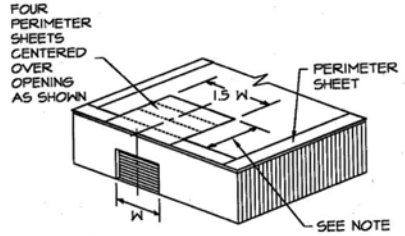

- iii. As an option to the above perimeter securement, an adhered membrane section may be used in lieu of the mechanically fastened membrane at large openings in accordance with the Carlisle Specification for the Sure-Seal/Sure-White Adhered Roofing System.

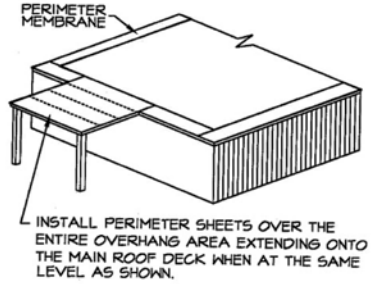

NOTE: Depth of perimeter area, noted above, shall not be less than 2.5 times the width of the opening.

f. **Buildings with overhangs**

The membrane must be specified with securement 3-1/2' to 4-1/2' over the entire overhang area extending onto the main roof deck a minimum of 3-1/2' when at the same level.

- i. This can be achieved utilizing 8' or 10' wide membrane sheets in conjunction with 9" wide Pressure-Sensitive RUSS as described above.
- ii. As an option, an adhered membrane section may be used in lieu of the mechanically fastened membrane at building overhangs in accordance with the Carlisle Specification for the Sure-Seal/Sure-White Adhered Roofing System.

6. **Field Membranes**

- a. **Position** field membrane sheets adjacent to perimeter membrane to allow a minimum 6" overlap, 3" from the center of the plate or bar in front and back.

NOTE: For 20-year warranty projects with a roof slope less than 1/4" in 12" (minimum 1/8" slope required) or when splices buck water, strip in seams with a 6" Pressure Sensitive Overlayment or Cured Cover Strip.

- b. **Secure the field and perimeter membrane sheets** along the pre-printed blue line approximately 3" from the edge of the membrane sheet at the approved fastening density with the required Carlisle Fastener and Carlisle Seam Plates or Bars. Refer to "Membrane Fastener Selection" Table in Paragraph 3.05 for further information.

Correct fastener placement must conform to the following:

- i. The **minimum** distance between the bottom membrane edge and the nearest edge of the fastening plate or bar must be 2".
- ii. The **minimum** distance between the overlapping membrane edge and the nearest edge of the fastening plate or bar must be 2".

- c. On new construction projects, where direct application of the membrane is specified over HP Protection Mat over lightweight insulating concrete, standard 2" diameter Seam Fastening Plates must be used since the Polymer Seam Plates will not properly seat.
- d. **Position** adjoining membrane sheets to allow a minimum overlap of 6" where Fastening Plates are located (along length of the membrane); at the same time overlap end roll sections (width of the membrane) a minimum of 3", for Projects with a maximum 15 Year Warranty. For 20 Year Warranties, end roll sections should be overlapped 6" with 6" SecurTAPE.
- e. Work shall progress across the roof with a minimum 6" overlap provided at the previously secured sheet edge. The opposite length of the sheet must be secured with approved Fastening Plates or bars and overlapped accordingly.

G. Membrane Splicing

1. General

a. Sure-Seal/Sure-White - Adhered or Ballasted Roofing Systems

i. Projects with 10, 15 and 20 year warranties – Detail U-2A and U-2A.1

Side Laps / End Laps: Tape splices must be a minimum of 2-½" wide using **3" wide field-applied Pressure Sensitive SecurTAPE OR 3" Factory-Applied TAPE (FAT)**. (Detail U-2A or U-2A.1).

Splice Intersections: 'T'-Joints are to be flashed with a bead of lap sealant and 6"x6" minimum (black) or 7"x9" (white) Pressure-Sensitive 'T'-Joint Cover, (for membranes of maximum thickness of 75 mil). (Detail U-2A). (Detail U-2A). **For membranes of thickness of 90 mil**, Apply a second layer of 12"x12" Pressure-Sensitive 'T'-Joint Cover centered over 6"x6" 'T'-Joint Cover. (Detail U-2A.1– Option 2)

NOTE: In lieu of the 6"x6" or 12"x12" Pressure-Sensitive 'T'-Joint cover, a 6"x6" or 12"x12" section of Pressure-Sensitive Elastoform flashing may be used as a 'T'-Joint cover. Pressure-Sensitive Elastoform flashing is available in rolls of 6", 9" and 12".

ii. Projects with 25 and 30 year warranties – Details U-2A.1 or U-2B.1

OPTION 1:

Side Laps / End Laps: Tape splices may be a minimum **3" wide Factory-Applied Tape (FAT) OR 3" wide Field-Applied SecurTAPE**. In addition the entire field splice must be overlaid with a continuous 6" wide Pressure Sensitive Overlayment Strip. **(See Detail U-2A.1-Option 1)**.

Splice Intersections: Overlay the entire field splice with a continuous 6" wide Pressure-Sensitive Overlayment Strip. Apply Lap Sealant at all Intersections between Pressure-Sensitive Overlayment Strip. **(See Detail U-2A.1-Option 1)**.

OPTION 2:

Side Laps / End Laps: Tape splices may be a minimum of 5-½" wide using **6" wide Factory-Applied Tape (FAT) OR 6" wide Field-Applied SecurTAPE**. (Detail U-2A.1– Option 2).

Splice Intersections: 'T'-Joints are to be flashed with a bead of lap sealant and 6"x6" minimum Pressure-Sensitive 'T'-Joint Cover. Apply a second layer of 12"x12" Pressure-Sensitive 'T'-Joint Cover centered over 6" x 6" 'T'-Joint Cover. **(Detail U-2A.1– Option 2)**.

NOTE: Pressure Sensitive Elastoform flashing is available only in rolls of 6", 9" or 12" rolls. Material used for Overlayment shall be cut from the appropriate roll.

- b. **Sure-Tough or Sure-White (reinforced) Mechanically Fastened Roofing Systems**
 - i. **Projects with 10, 15 and 20 year Warranties – Detail MF-2A and MF-2B**

Side Laps: Regardless of Warranty duration, where fastening plates are placed, shall be spliced using **6" wide Factory-Applied Tape (FAT) OR 6" wide Field-Applied SecurTAPE**. The splice tape shall be centered over the plates to extend approximately 2" on each side. SecurTAPE must extend approximately ¼" beyond the edge of the overlapping membrane. **(Detail MF-2A)**.

End Laps: Shall be spliced using either **3" wide SecurTAPE** resulting in a minimum splice of 2-½" wide for a maximum of 20 year warranties. **(Detail MF-2B)**.

Splice Intersections: 'T'-Joints are to be flashed with a bead of lap sealant and 6"x6" pressure sensitive 'T'-Joint Cover, (for membranes of maximum thickness of 75 mil). **(Detail MF-2A)**.
 - ii. **Projects with 25 and 30 year Warranties – Detail MF-2D and MF-2B**

Side Laps: Where fastening plates are placed, shall be spliced using **6" wide Factory-Applied Tape (FAT) OR 6" wide Field-Applied SecurTAPE**. The splice tape shall be centered over the plates to extend approximately 2" on each side. SecurTAPE must extend approximately ¼" beyond the edge of the overlapping membrane. **(Detail MF-2D)**.

End Laps: Shall be spliced using **6" wide Factory-Applied Tape (FAT) OR 6" wide Field-Applied SecurTAPE** resulting in a minimum splice of 5-½" wide for a maximum of 30 year warranties. **(Detail MF-2B)**.

Splice Intersections: 'T'-Joints are to be flashed with a bead of lap sealant and 6"x6" Pressure Sensitive 'T'-Joint Cover. Apply a second layer of 12"x12" Pressure Sensitive 'T'-Joint Cover centered over 6" x 6" 'T'-Joint Cover. **(Detail MF-2D)**.
- 2. For Splicing procedures, cautions and warnings refer to **Spec Supplement E-02-20 "EPDM Membrane Splicing and Splice Repairs"** for information.

H. **Additional Membrane Securement**

Securement must be provided at the perimeter of each roof level, roof section, expansion joint, curb flashing, skylight, interior wall, penthouse, etc., at any inside angle change where slope exceeds 2" in one horizontal foot, **and at other penetrations** in accordance with Carlisle's details and securement options as listed below.

Securement may be achieved as follows:

- 1. **Pressure-Sensitive RUSS (Reinforced Universal Securement Strip)**

Pressure-Sensitive RUSS is a 6" wide strip of reinforced EPDM membrane with factory-applied 3" wide SecurTAPE and is installed in conjunction with Sure-Seal Fasteners and 2" diameter Seam Fastening Plates spaced a maximum of 12" on center below the EPDM deck membrane (Polymer Seam Plates or Polymer Batten Strips are required for Mechanically Fastened Roofing Systems over steel decks). The securement strip can be fastened horizontally to the structural deck or vertically at walls and curbs.

 - a. Loose lay the 6" wide Pressure-Sensitive RUSS along parapet walls 6" to 9" from corners and fasten with Seam Fastening Plates and the appropriate Carlisle fastener to the roof deck or into the parapet wall. Spacing of the Seam Fastening Plates shall be a maximum of 12" on center for up to 20 year warranties (less than 90 mph warranty wind speed) and a maximum of 6" on center for 25 and 30 year warranties.
 - i. For horizontal attachment, the reinforced strip must be positioned a minimum of ¼" to a maximum of 6" away from the angle change with pressure sensitive side facing away from the parapet and towards the roof plane.

- ii. For vertical attachment, the reinforced strip must be attached to the vertical wall with pressure sensitive side extending onto the roof surface.
CAUTION: Horizontal RUSS attachment is required when insulation is attached with adhesives to a vapor barrier or an existing asphalt based roof. For various options, Refer to **Spec Supplement G-08-20 "Application Procedures for Carlisle's VapAir Seal 725TR Air and Vapor Barrier"**.
- b. Adjoining sections of the reinforced strip need not be overlapped; however, gaps between adjoining sections must not exceed 1".
CAUTION: When RUSS is used for membrane securement along metal edgings, refer to the appropriate detail for applicable installation criteria. For some metal edge details, adjoining sections of the reinforced strip must be overlapped and spliced.
- c. **When using Pressure-Sensitive RUSS, clean the underside of the membrane with Carlisle Primer** and allow proper flash-off prior to removing the release film from the RUSS.
CAUTION: On Adhered Systems discontinue bonding adhesive application on the underside of the membrane in area of the sheet where contact with the Pressure-Sensitive RUSS is to occur. Contact between Pressure-Sensitive RUSS and membrane coated with bonding adhesive can result in poor peel and shear values.

2. **Seam Fastening Plates**

When the use of Pressure-Sensitive RUSS is not feasible (at smaller curbs or skylights), a 2" diameter Seam Fastening Plates may be used.

- a. Seam Fastening Plates may be installed horizontally into the structural deck or into walls or curbs.
- b. Securement of the EPDM membrane with the approved Carlisle Fasteners and Seam Fastening Plates must be a maximum of 12" on center starting 6" minimum to 9" maximum from inside and outside corners.
- c. If horizontal wood nailers are provided, secure the Seam Fastening Plates to the wood nailer with Carlisle HP Fasteners. Nails (i.e. ringshank, roofing, etc.) are not acceptable for securement.
- d. After securing the Seam Fastening Plates, flash in accordance with the appropriate Carlisle Detail.

3.06 Flashings

For other requirements which must be complied with in order for Carlisle warranty to be issued, refer to Spec Supplement G-05-22 "Flashing Considerations / Metal Work".

A. **General Considerations**

- 1. All vertical field splices at the base of a wall or curb must be overlaid with Pressure-Sensitive "T" Joint Covers, a 6" x 6" section (with rounded corners) of Sure-Seal/Sure-White Pressure-Sensitive Uncured Elastoform Flashing centered over the field splice.
- 2. **Pressure-Sensitive Uncured Elastoform Flashing** must be limited to the overlayment of vertical seams (as required at angle changes), or to flash inside/outside corners, vent pipes, scuppers and other unusually shaped penetrations where the use of Pre-molded Pipe Seals, cured EPDM membrane or Pressure-Sensitive Cured Cover Strip or Overlayment Strip is not practical

NOTE: When using Pressure-Sensitive products in colder temperatures, use a heat gun to warm the product. Apply heat to the EPDM flashing side of the product. Do not apply heat directly to the preapplied adhesive. The Pressure-Sensitive Flashing must be applied immediately after Primer flashes off. Refer to “Membrane Splicing with SecurTAPE” for application procedures in colder temperatures.

3. When using **Pressure-Sensitive Cured Cover Strip or Overlayment Strip** to overlay Seam Fastening Plates or metal edging, etc., **Sure-Seal HP-250 or LOW-VOC Primer** must be used to clean the membrane and metal flanges.
4. Special requirements may apply for certain flashing details for projects with extended warranty durations. Refer to Carlisle published details for applicable requirements when warranty coverage exceeds beyond 20 years.

B. Walls, Parapets, Curbs, Skylights, etc.

1. Use continuous deck membrane with Pressure-Sensitive RUSS or Seam Fastening Plates along the angle change.
 - a. When using Pressure-Sensitive RUSS, refer to Paragraph 3.05 G, Additional Membrane Securement, for attachment criteria.
 - b. When Seam Fastening Plates are used to secure continuous deck membrane, use minimum 6" wide Pressure-Sensitive Cured Cover Strip or Overlayment Strip to overlay fasteners and plates.
2. When the use of continuous deck membrane for wall flashing is not feasible, a separate piece of cured EPDM membrane may be used.

NOTE: 60 mil cured non reinforced membrane may be used as a separate wall flashing with projects of warranty 20 years or greater. The flashing may also incorporate membrane equal of thickness to that of the EPDM membrane at the deck level.

3. Adhere flashing to the wall and terminate in accordance with the applicable Carlisle Detail.
 4. Use a “T” Joint Cover or 6" x 6" Pressure-Sensitive Elastoform Flashing with rounded corners to overlay vertical splices as shown on the applicable Carlisle Detail.
 5. Refer to applicable Carlisle Details for various corner flashing options.
- C. Flashing of other Penetrations,** refer to **Spec Supplement G-05-22 for “Flashing Considerations / Metal Work”** and the applicable Carlisle detail for specific requirements.
- D. Flashing of Difficult Penetrations,** refer to **Spec Supplement G-13-20 for “LIQUISEAL Liquid Flashing”** for additional information and specific requirements.

3.07 Roof Walkways

Walkways are to be installed at all traffic concentration points (i.e., roof hatches, access doors, rooftop ladders, etc.), other locations designated by specifier, and if regular maintenance (once a month or more) is necessary to service rooftop equipment. Refer to **Spec Supplement G-06-21 “Roof Walkway Installations”**.

3.08 Daily Seal

On phased roofing, when the completion of flashings and terminations is not possible by the end of each workday, provisions must be taken to temporarily close the membrane to prevent water infiltration. Refer to **Spec Supplement G-07-20 “Daily Seal / Clean Up”**.

3.09 Optional Color Coating

- A. **If optional color coating is specified, Carlisle’s final inspection for warranty must be conducted prior to the coating application.** This will permit the completion of any “Repair for Warranty” items without consideration for the removal and reapplication of the coating. The owner will then verify that the coating was applied after receiving the warranty.
- B. If **Sure-Seal X-Tenda Coat** is specified to color the membrane surface, refer to the Carlisle X-Tenda Coat Specification for installation requirements.

3.10 Clean Up

For Daily tie-off or cleaning procedures refer to **Spec Supplement G-07-20 “Daily Seal / Clean Up”** in the Carlisle Technical Manual.

A. General

1. Termination bars and surface mounted reglets must be installed directly to the wall surface.
2. Carlisle recommends SecurEdge Metal Edging/Coping, Sure-Seal Termination Bar or Sure-Seal Drip Edge for membrane termination. Installation instruction sheets for Carlisle supplied accessories are available from Carlisle.
NOTE: Refer to Warranty Tables in Section 1.05 for specific metal edge requirements for projects with Total System Warranties or those with extended peak gust wind speed coverage greater than 80 miles per hour.
3. Metal work by others, when specified, must be fastened to prevent the metal from pulling free or buckling and sealed to prevent moisture from entering the roofing system or building. **Unless supplied by Carlisle, metal work securement is not included in this specification and is excluded from the Carlisle warranty.**
4. **On retrofit projects**, existing counter flashing, edging, expansion joint covers, copings, etc., shall not be reused unless investigated by the specifier to determine its compliance to Carlisle’s current details.

Sure-Seal Design "B" Loose-Laid Ballasted Roofing Systems
"Attachment I"
Ballast Criteria
July 2023

A. General

The specifier must evaluate the various conditions by which the ballast requirements are dictated. Building height, parapet height and project wind zone are major factors when specifying a minimum ballast requirement. The guidelines for ballast requirements which have been published by the following organizations should be referenced:

1. American National Standards Institute, ANSI/SPRI RP-4 (current edition) Wind Design Guide for Ballasted Single-Ply Roofing Systems. This standard is referenced in the current edition of the International Building Code (IBC).
2. Factory Mutual (FM) Research Corporation Loss Prevention Data Sheets 1-28 and 1-29.

B. Ballast Types/Coverage Rates

The coverage rates listed below are considered minimum and are required by Carlisle for the issuance of the Carlisle warranty. Additional ballast coverage rates may be specified to provide additional wind uplift resistance.

1. **Rounded Water-Worn Gravel** may be placed directly on the EPDM membrane without additional membrane protection.
 - a. Minimum acceptable gradation:
 - i. Nominal 1-1/2" rounded water worn gravel which conforms to the following gradation: 50% retained by a 3/4" screen, 95% retained by a 1/2" screen and 98% retained by a 1/4" screen. Use ASTM C136 method for sizing gravel.
 - ii. Alternately, #4, #3 and #24 stone (sized in accordance with ASTM D7765 method of sizing) may be used in lieu of the stone listed above.
 - iii. Coverage rate shall be no less than 1000 pounds per 100 square feet and ballast must be evenly distributed to maintain an average of 10 pounds per square foot.
 - b. Nominal 2-1/2" rounded water worn gravel which conforms to gradation #1 or #2 when sized in accordance with ASTM D7765 method of sizing. Coverage rate shall be no less than 1300 pounds per 100 square feet and gravel must be evenly distributed to maintain an average of 13 pounds per square foot.
2. **Standard sizes of coarse aggregate** - Based on ASTM D7655

Size Number	1	2	3	4
Nominal Size Square Openings	3-1/2" to 1-1/2"	2-1/2" to 1-1/2"	2" to 1"	1-1/2" to 3/4"
Amounts Passing Each Lab Sieve (Square Opening), Percent (%)				
4"	100			
3-1/2"	90 to 100			
3"		100		
2-1/2"	25 to 60	90 to 100	100	
2"		35 to 70	90 to 100	100
1-1/2"	0 to 15	0 to 15	0 to 15	90 to 100
1"				20 to 55
3/4"	0 to 5	0 to 5		0 to 15
1/2"			0 to 5	
3/8"				0 to 5

3. **Crushed Stone**, when specified, shall conform to the gradations approved for rounded water-worn gravel and must be installed in conjunction with Sure-Seal HP Protective Mat.
 - a. HP Protective Mat must extend a minimum of 2" above the crushed stone at the perimeter and penetrations, but must be discontinued at scuppers, Dutch gutters and at drain bases.
 - b. A minimum 6" overlap between adjacent sheets of HP Protective Mat must be specified.

4. **Individual Concrete Pavers**

- a. Individual pavers with a minimum weight of 18 pounds per square foot may be substituted for nominal 1-½" stone. Individual pavers with a minimum weight of 22 pounds per square foot may be substituted for nominal 2-½" stone.
- b. Individual pavers must be a maximum of two feet square. Unless otherwise required by Carlisle, pavers must weigh no more than 100 pounds per unit to allow for easy removal and replacement.
- c. Individual pavers with a surface other than a steel troweled finish as approved by Carlisle, must be installed over Sure-Seal HP Protective Mat and must be accepted by Carlisle prior to installation.

Elevating pavers should increase life expectancy, reduce freeze/thaw effects and promote more positive drainage. Acceptable pedestals can be specified under corners of pavers to elevate paver.
- d. Individual concrete pavers shall be loose laid and butted together with no gaps greater than ½".

5. **Lightweight Interlocking Concrete Pavers**

- a. Depending on the type of lightweight interlocking system, Sure-Seal HP Protective Mat or manufacturer's recommended matting may be required by Carlisle as a protection layer for the membrane. **Carlisle must be consulted prior to installation concerning protective matting requirements.**
- b. Lightweight interlocking pavers (minimum 10 pounds per square foot) may be substituted for nominal 1-½" stone or nominal 2-½" stone.
- c. When lightweight interlocking pavers are specified, the respective paver manufacturer must be consulted concerning installation criteria.

CAUTION: The securement method suggested by the respective interlocking paver manufacturer must be reviewed by Carlisle to determine membrane accessibility. If access to the membrane system is impaired by the paver interlocking mechanism (mechanical clips, strapping, adhesive, etc.), the building owner must assume the responsibility of providing access to the membrane for the purpose of investigation and warranty related repairs.

- d. Lightweight Ballast Paver – 2' x 2' x 1.25" weighing 15 lbs/sq. ft.

6. **Walkways**

CAUTION: Molded Walkway pads not recommended within 10 feet of the perimeter of the roof on ballasted systems to avoid discontinuation of the primary membrane securement (ballast). In lieu of molded walkway pads, concrete pavers can be used when walkway is to be extended into the perimeter area.

- a. **Sure-Seal/Sure-White Pressure-Sensitive Walkway Pads:** Sure-Seal (black) or Sure-White (white) molded walkway pads with Pressure Sensitive TAPE used to provide protection for areas of EPDM membrane that are exposed to regular rooftop maintenance.

b. **Carlisle Sure-Seal Interlocking Rubber Pavers:** A 2' x 2' x 2" thick rubber paver weighing approximately 24 pounds per unit, 6 pounds per square foot manufactured from recycled rubber, which provides a resilient, shock absorbing, weather resistant surface. Designed primarily for use as a walkway or on terrace areas offering an environmentally sound design. Paver features bi-directional drainage and freeze/thaw stability. The Sure-Seal Rubber Paver can be installed directly over the EPDM membrane without a separation layer.

c. **Hanover Pedestal Paver** – Used for light traffic areas associated with rooftop or garden roof applications. 2'x2'x2.25" thick precast concrete pavers weighing 22 psf with an elevated clearance of ½" from incorporated footing. The pedestal paver can either be installed in conjunction with a separation layer of HP Protective Mat or using Pedestal and shims.

NOTE: EPDM Pedestal and Leveling Shims – A ¾" fixed height EPDM rubber pedestal incorporating ¼" spacer tabs. The pedestal allows pavers to follow the contour of the roof and may be combined with ¼" or ⅙" leveling shims to prevent paver movement and provide a more stable feel. Both Hanover Pavers and leveling shims are available from Carlisle. (Refer to product section **Spec Supplement P-01-22 "Related Products"**.)

d. **Hanover Ballast and Lightweight Ballast Paver** - The standard, 24" x 24" x 1-¹³/₁₆" thick, Ballast Paver comes in a natural color and a non-slip Diamond finish and weighs 22 lbs/sq. ft. The Lightweight, 23-½" x 23-½" x 1-¼" thick, Ballast Paver comes in a natural color and a non-slip diamond finish and weighs 15 lbs/sq. ft. Both pavers can be used as ballast or walkways.

e. **Other Walkway Considerations:**

Smooth concrete pavers when specified in conjunction with insulation that is mechanically fastened, must be loose laid over a slip sheet of membrane or 2 layers of HP Protective Mat. When insulation is attached with Flexible FAST Adhesive, concrete pavers may be placed over one layer of HP Protective Mat. Pavers cannot weigh more than 100 pounds per paver for ease of removal.

- i. Walkways are considered a maintenance item and are excluded from the Carlisle warranty.
- ii. Window washing equipment will require special maintenance. Runways or window washing tracks must be utilized to prevent damage to membrane or insulation. Such details must be reviewed by Carlisle to determine reasonable access to the membrane and associated insulation/underlayment components.

Sure-Seal/Sure-White/Sure-Tough EPDM Roofing Systems
Adhered, Ballasted and Mechanically Fastened
“Attachment II”
25/30 Year Warranty
Design Enhancements
July 2023

A. General

1. All products specified for these roofing assemblies must be products manufactured or marketed by Carlisle.
2. On retrofit projects, all existing roofing material shall be totally removed.
3. All projects, a final shop drawing shall be approved by Carlisle prior to installation. Shop drawings must include all pertaining details. As-Built projects are not recommended.
4. The roof assembly will vary based on warranty wind speed and hail coverage. As identified in Warranty Tables, included in this attachment.
5. An air/vapor barrier shall be used when required and must be sealed around perimeter and roof penetrations. When not specified, the roof membrane shall be adhered over perimeter wood nailer along edges to prevent air infiltration along edging, regardless of assembly type (Ballasted, Adhered and Mechanically Fastened).
6. Due to warranty length, covered in this attachment, special consideration should be given to the total R-Value of the roof assembly. Utilizing the International Energy Conservation Code (IECC) to determine the minimum level of insulation for the building project's location is recommended.
7. To optimize energy efficiency, insulation shall be installed in multiple layers with joints staggered.
8. For limitations and specific types of insulation/underlayments refer to “Section E Insulation/Underlayments”
9. ¼" per horizontal foot slope is preferred; however, ⅛" slope with sufficient number of drains and crickets / saddles may be accepted. Assemblies described in this attachment are governed by the maximum slope limit described in the current Carlisle publication.
10. Refer to **Spec Supplement E-02-20 “EPDM Membrane Splicing and Splice Repairs”** and applicable Carlisle Details for additional design enhancements.

B. Membrane Criteria

1. **Adhered Roofing Systems**, the roofing membrane shall be a minimum of **60-mil thick Sure-Seal/Sure-White Non-Reinforced Membrane** utilizing enhanced details for **25 Year Warranty** Duration
OR
90-mil Sure-Seal Non-Reinforced Membrane OR 75-mil thick Sure-Tough Reinforced Membrane utilizing enhanced details for **30 Year Warranty** Duration.
2. **Ballasted Roofing Systems**, the roofing membrane shall be a minimum of **60-mil thick Sure-Seal Non-Reinforced Membrane** utilizing enhanced details for **25 Year Warranty** Duration
OR
90-mil thick Sure-Seal Non-Reinforced Membrane utilizing enhanced details for **30 Year Warranty** Duration. Maximum membrane width, not to exceed 10' wide.
3. **Mechanically Fastened Roofing Systems**, the roofing membrane shall be a minimum of **75-mil thick Sure-Tough Reinforced Membrane** utilizing enhanced details for 25- or 30-Year Warranty Duration.

4. Non-Reinforced Membrane Criteria and Hail Coverage

Years	Sure-Seal or Sure-White Non-Reinforced Membranes					
	Warranty Wind Speed Coverage				Minimum Membrane Thickness	Hail Coverage
	55, 72 or 80 mph		90 to 100 mph	110 to 120 mph		
	Adhered (2)	Ballasted (1)	Adhered (2)	Adhered (2)		
25 year	√	√	√	N/A	Sure-Seal/Sure-White 60-mil	Adhered Systems (Sure-Seal / Sure-White) 1" Dia. Hail Coverage requires a min. 60-mil Adhered to Cover Board. 2" Dia. Hail Coverage requires a min. 90-mil Adhered to Cover Board. Additional Design Requirement Cover Board set in Flexible FAST Adhesive (SecurShield HD, SecurShield HD Plus, DensDeck Prime, DensDeck StormX Prime, or Securock - Adhered Only). Ballasted Systems (Sure-Seal) 1" or 2" Dia. Hail Coverage requires a min. 60-mil. 3" Dia. Hail Coverage requires a min. 90-mil.
30 year	√	√	√	N/A	Sure-Seal / Sure-White 90-mil	

Notes: N/A = Not Acceptable √= Acceptable

- (1) Sure-White membrane is not recommended for ballasted systems.
 (2) Standard 90-8-30A, EPDM x-23 Low-VOC, or CAV-GRIP III Bonding Adhesive must be utilized.

5. Reinforced Membrane Criteria and Hail Coverage

Years	Sure-Tough Reinforced Membranes							
	Warranty Wind Speed Coverage				Minimum Membrane Thickness	Hail Coverage (Adhered Systems Only)		
	55, 72 or 80 mph		90 mph				100 to 120 mph	
	Adhered (1)	Mech. Fastened	Adhered (1)	Mech. Fastened			Adhered (1)	Mech. Fastened
25 year	√	√	√	√	√	N/A	Sure-Tough 75-mil	1" Dia. Hail Coverage requires a Min. 60-mil Adhered to Cover Board. 2" Dia. Hail Coverage requires a Min. 75-mil Adhered to Cover Board. Additional Design Requirement: Cover Board set in Flexible FAST Adhesive (SecurShield HD, SecurShield HD Plus, DensDeck Prime, DensDeck StormX Prime or Securock - Adhered Only).
30 year	√	√	√	√	√	N/A	Sure-Tough 75-mil	

Notes: N/A = Not Acceptable √= Acceptable
 (1) Standard 90-8-30A, EPDM x-23 Low-VOC, or CAV-GRIP III Bonding Adhesive must be utilized.

C. Adhered System Design Criteria (25 YR to 30 YR Warranty)

- Building height shall not exceed 100'. For projects where building height exceeds 100' or warranty wind speed exceeds 100 mph, please submit to Carlisle for review.
- Local Wind Zone per ASCE 7-2010 (Category II Map) shall not exceed 120 mph.
- All Field Splice "T-Joints" must be overlaid as described in **Detail U-2A.1**.
- The criteria is for compliance with Carlisle's requirements for warranty, when FM Compliance is required for a specific project refer to FM Documentation and Carlisle Code Listings.
- 6" on center fastening required for Pressure Sensitive RUSS.
- Table below outlines insulation/underlayment requirements and application attachment methods:

Maximum Peak Gust Wind Speed Warranty	Minimum Membrane Underlayment		Insulation/Underlayment Attachment			Metal Edging
			# of Fasteners per 4' x 8' board size	Adhesive Ribbon Spacing for 4' x 4' size board		
				Field	Perimeter	
55 or 72 MPH	1-1/2" to 2" (25 psi) Polyisocyanurate (1)		16	6" (4)	6"	Carlisle Drip Edge or SecurEdge 200, 300, or 400 may be fastened with ring shank nails staggered 4" on center. Carlisle HP or HP-X Fasteners may also be used fastened 12" on center.
	Cover Board over Insulation	1/2" HP Recovery Board (2)(6)				
		1/2" SecurShield HD (3)				
		1/2" SecurShield HD Plus (3)				
		1/4" DensDeck Prime (3)				
		1/4" Securock (3)				
80 MPH	1-1/2" to 2" (25-psi) SecurShield Polyiso		20	6"	6"	Carlisle Drip Edge (5), SecurEdge 2000, 3000 or 4000.
	Cover Board over Insulation	1/2" SecurShield HD (3)	16			
		1/2" SecurShield HD Plus (3)				
		1/2" DensDeck Prime (3)				
		1/2" Securock (3)				
90 MPH	Cover Board over Insulation	1/2" SecurShield HD (3)	24	FS	FS	SecurEdge 2000 or 3000
		1/2" SecurShield HD Plus (3)	20			
		1/2" DensDeck Prime (3)				
		1/2" Securock (3)				
100 MPH	Cover Board over Insulation	5/8" DensDeck Prime or 5/8" DensDeck StormX Prime (3)	16	FS	FS	SecurEdge 2000 or 3000
		5/8" Securock (3)				
		1-1/2" StormBase (OSB/Polyiso Composite) (3)				
		1/2" DuraStorm VSH (3)				
		2" SecurShield HD Composite (3)				
		1/2" SecurShield HD Plus (3)				

Notes:

FS = Full Spray or Ribbons @ 4" O.C.

All Carlisle Products listed for higher wind speed coverage can also be used for Warranties for lower speed coverage. (i.e. 72 MPH underlayment may be used for 55 MPH underlayment)

- (1) Not for use directly on concrete decks when adhesion is specified to the structural deck.
- (2) For Building heights between 51'-100', enhance 12'-wide perimeter with 50% more fasteners and plates.
- (3) Nail coverage offered with substrate when Flexible FAST Adhesive is used for cover board attachment.
- (4) Structural Concrete - Field @ 12" O.C. / Perimeter @ 6" O.C.
- (5) Carlisle HP or HP-X Fasteners must be used to secure Carlisle Drip Edge to perimeter wood nailers.
- (6) 1/2" Recovery Board limited to 55 mph.

D. Mechanically Fastened System Design Criteria (25 YR to 30 YR Warranty)

1. Building height limitation depends on structural deck type. Projects with structural concrete or steel decks are limited to 100' in height. Projects with plywood decks (3/4" min.) are limited to a maximum height of 30'. Projects with Wood plank (1" min.) are limited to a maximum height of 60'. For projects where building height exceeds 100' or warranty wind speed exceeds 100 mph, please submit to Carlisle for review.
2. Local Wind Zone per ASCE 7-2010 (Category II Map) shall not exceed 120 mph.
3. All Field Splice "T-Joints" must be overlaid as described in **Detail MF-2D**.
4. This criteria is for compliance with Carlisle's requirements for extended warranties, when FM Compliance is required for a specific project refer to FM Documentation and Carlisle Code Listings.
5. Fasteners covered in this attachment are limited to a length not to exceed 12". Assemblies with Tapered Insulation, requiring longer fasteners than 12", shall be reviewed by Carlisle.
6. 6" on center fastening required for Pressure Sensitive RUSS.
7. Table below outlines insulation/underlayment requirements and application attachment methods:

Maximum Peak Gust Wind Speed Warranty	Deck Type	Insulation Thickness	Minimum Membrane Underlayment	Insulation Underlayment Attachment	Metal Edging
				# of Fasteners per 4' x 8' board size	
Up to 72 MPH	Steel, Concrete or Wood Deck	< 5"	1-1/2" to 2-1/2" (25 psi) InsulBase or SecurShield Polyisocyanurate	6	Carlisle Drip Edge, SecurEdge 200, 300, or 400 may be fastened with ring shank nails staggered 4" on center. Carlisle HP or HP-X Fasteners may also be used fastened 12" on center.
		> 5"	Overlay 1/2" SecurShield HD Cover Board over InsulBase or SecurShield Polyisocyanurate	4	
80 MPH	Steel or Concrete Deck	Any Thickness	Overlay 1/2" SecurShield HD Cover Board over InsulBase or SecurShield Polyisocyanurate	4	Carlisle Drip Edge (1) or SecurEdge 2000, 3000 or 4000.
90 MPH	Steel or Concrete Deck	Any Thickness	Overlay 1/2" SecurShield HD Cover Board over InsulBase or SecurShield Polyisocyanurate	4	SecurEdge 2000 or 3000

Notes:

- (1) Carlisle HP or HP-X Fasteners must be used to secure Carlisle Drip Edge to perimeter wood nailers.
- (2) An air/vapor barrier shall be used when required and must be sealed around perimeter and roof penetrations. When not specified, the roof membrane shall be adhered over perimeter wood nailer along edges to prevent air infiltration along edging, regardless of assembly type.

(Sure-Tough Only)
22 GA. Steel Deck or Structural Concrete

Peak Gust Wind Speed Warranty	Max. Building Height	Min. Number of Perimeter Sheets			Field Membrane Width	Perimeter Sheet Width	Fastening Density (Field Sheets)	Fastening Density (Perimeter Sheets)
		Building Distance from Coastline						
		Greater than 7 miles	3 to 7 miles	Less than 3 miles				
55 MPH	Up to 60'	2	3	4	10'	Note 3	12" O.C.(1)	12" O.C.(1)
	61' to 100'	3	3	4	10'	Note 3	6" O.C.(1)	6" O.C.(1)
72 MPH	Up to 60'	3	3	4	10'	Note 3	6" O.C.(1)	6" O.C.(1)
	61' to 100'	4	5	5	10'	Note 3	6" O.C.(1)	6" O.C.(1)
80 MPH	Up to 60'	4	4	5	10'	Note 3	12" O.C.(2)	12" O.C.(2)
	61' to 100'	4	5	5	10'	Note 3	12" O.C.(2)	12" O.C.(2)
90 MPH	Up to 60'	4	5	5	10'	Note 3	12" O.C.(2)	12" O.C.(2)
	61' to 100'	5	5	5	10'	Note 3	12" O.C.(2)	6" O.C.(2)

- (1) Using HP Fasteners On Steel Deck with 2" Polymer Seam Plates
- (2) Using HP-Xtra Fasteners and 2-3/8" Polymer (HP-Xtra) Seam Plates
- (3) Split Field sheet using a 9" Pressure Sensitive RUSS along the center of the sheet.

**(Sure-Tough Only)
Wood Decks**

Peak Gust Wind Speed Warranty	Deck Type	Projected Pull-Out Values	Min. Number of Perimeter Sheets		Field Membrane Width	Perimeter Sheet Width	Fastening Density (Field & Perimeter Sheets)
			Building Distance from Coastline				
			Greater than 7 miles	Less than or equal to 7 miles			
55 MPH	3/4" Plywood (2)	450 lbs	2	2	10'	Note 1	12" O.C.
72 MPH	Wood Plank (3)	540 lbs	2	2	10'	Note 1	12" O.C.
	3/4" Plywood (3)	450 lbs	2	4	10'	Note 1	12" O.C.
80 MPH	Wood Plank (3)	540 lbs	2	4	10'	Note 1	6" O.C.

(1) Split Field sheet using a 9" Pressure Sensitive RUSS along the center of the sheet.

(2) Maximum Building Height Up to 30'

(3) Maximum Building Height Up to 60'

E. Ballasted Design Criteria (25 YR to 30 YR Warranty)

- Building height shall not exceed 60'. For projects where building height exceeds 60' or warranty wind speed exceeds 80 mph, please submit to Carlisle for review.
- Local Wind Zone per ASCE 7-2010 (Category II Map) shall not exceed 115 mph. Projects in greater wind zones may be submitted for review by Carlisle.
- All Field Splice "T-Joints" must be overlaid as described in **Detail U-2A.1**.
- For applicable membrane thickness, refer to Tables in Section B4.
- 6" on center fastening required for Pressure Sensitive RUSS.

General

- Carlisle Polyisocyanurate or Insulfoam EPS Insulation shall be applied in multiple layers with joints staggered between layers, following current energy codes. The layer directly under the membrane shall be 1-1/2" thick insulation and shall be loose-laid or, if specified, may be secured with bead adhesive (12" O.C. bead spacing is acceptable).

CAUTION: The use of Mechanically Fasteners is not permitted for insulation securement.

Polyisocyanurate Insulation

- When Polyisocyanurate insulation is specified, Carlisle InsulBase or SecurShield (20 or 25 psi) shall be utilized and is recommended. On structural and lightweight structural concrete, to safeguard against residual moisture, the use of SecurShield Polyisocyanurate is required.

Expanded Polystyrene (EPS) Insulation

- When EPS (Expanded Polystyrene) insulation is to be utilized, only Insulfoam EPS may be used as follows:
 - Insulfoam I (1.0 pcf density) EPS.
 - Insulfoam VIII (1.25 pcf density) EPS.
- On steel decks, install EPS insulation in conjunction with thermal barrier, if required for code compliance.
- When directly installed on steel deck, total thickness of insulation must be adequate to span deck flutes.

Ballast Types/Coverage Rates

- The coverage rates listed in this attachment are considered minimum and are required by Carlisle for issuance of the standard Carlisle warranty. Depending on specific project conditions (building height, parapet height and project location), additional ballast may be necessary to provide wind uplift protection. Refer to "Attachment I" in this Specification for suitable ballast types and coverage rates. **Comply with the specifier's requirements when an additional ballast coverage rate is specified.**
- Rounded Water-Worn Gravel** must be applied over the EPDM membrane at the minimum rate of **1000 pounds per square** and must be evenly distributed to maintain an average of 10 pounds per square foot.

ASTM D 7765 SIZE NUMBER	MINIMUM COVERAGE RATE (pounds per square)	AVERAGE COVERAGE RATE (lbs./sq. ft. continuously distributed)
4 (1-1/2" nominal diameter)	1000	10
3 (2" nominal diameter)	1000	10
2 (2-1/2" nominal diameter)	1300	13
1 (3-1/2" nominal diameter)	1300	13

Notes: In the field of the roof, some bare spots resulting from installation are permitted; however, they must not exceed 64 square inches and must be limited to no more than 2 per square (100 square feet). No bare spots are permitted in the perimeter area of the roof that is 10' wide.

- Smooth Surfaced Individual Concrete Pavers**
 - When the use of concrete paver is specified, Carlisle supplied Hanover Pedestal Paver is recommended and can be covered by the Carlisle Warranty. A pedestal system is recommended, due to increased life expectancy, however, field fabricated, cut sections (8" x 8") of Sure-Seal/Sure-White Walkway Pads, beneath pavers, at corners of pavers.
 - Individual pavers must be a maximum of two feet square. Unless otherwise required by Carlisle, pavers must weigh no more than 100 pounds per unit to allow for easy removal and replacement.
 - Individual pavers with a surface other than a steel troweled finish as approved by Carlisle, must be installed over Sure-Seal HP Protective Mat and must be accepted by Carlisle prior to installation.
 - Elevating pavers should increase life expectancy, reduce freeze/thaw effects and promote more positive drainage. Acceptable pedestals can be specified under corners of pavers to elevate paver.
 - Individual concrete pavers shall be loose laid and butted together with no gaps greater than 1/2".

Ballast Criteria for Up to 30 Year Extended Warranty

- Refer to installations below for calculating corner/perimeter areas for the noted warranty wind speeds available.

Ballast Requirements for 72 mph Warranty

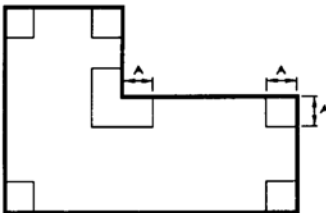

A (Corners) = .4 Times the Building Height
(10' minimum)

Ballast Requirements for 80 mph Warranty

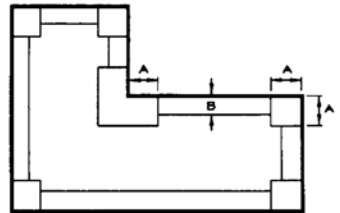

A (Corners) = .4 Times the Building Height
(10' minimum)
B (Perimeters) = 10'

2. At corner and/or perimeter areas, ballast shall be 2-½" nominal rounded water worn gravel conforming to gradation #1 or #2 in accordance with ASTM D7765 method of sizing. Coverage rate shall be a minimum of 15 pounds per square foot.
3. In field areas, ballast shall be 1-½" nominal rounded water worn gravel conforming to gradation #4 in accordance with ASTM-D7765 method of sizing. Coverage rate shall be a minimum of 12 pounds per square foot.
4. Other ballasting configurations may be authorized by Carlisle, upon review and approval, prior to construction.

F. Roof Deck Criteria

1. Steel (22 gauge or heavier) – **HP, HP-Xtra or InsulFAST Fasteners are required, with a minimum pullout of not less than 450 pounds per fastener.**

NOTE: Carlisle InsulFAST fasteners may be used with adhered systems only, if the minimum pullout requirement is met.

2. Structural Concrete (minimum 3,000 psi) – **HD 14-10 (threaded) Fasteners are required with a minimum pullout of 800 pounds per fastener.** Sure-Seal CD-10 (hammer-driven) is also applicable for adhered membrane assemblies. **In lieu of fastening, Flexible Adhesive is an acceptable alternative for insulation attachment for adhered assembly when used in conjunction with coated glass faced insulation and full spray.**

NOTE: The use of standard (paper) faced Polyisocyanurate is not acceptable. Due to possible presence of residual moisture in concrete slabs.

3. Wood Plank (minimum 1" thick) or minimum ¾" thick Plywood – **HP or InsulFAST Fasteners are required with a minimum pullout of 450 pounds for plywood and 540 pounds for wood planks.**

NOTE: Carlisle InsulFAST fasteners may be used with adhered systems only, if the minimum pullout requirement is met.

4. For **Ballasted Assemblies**, the structural deck must be able to sustain the weight of a ballasted assembly (12-15 lbs of ballast, as well as other components, i.e. membrane, insulation and vapor barriers, if applicable). The structural deck must be sufficient to support concentrated construction traffic and point loading.

G. Flashing, Terminations and Other Considerations (All Assemblies)

1. All existing flashing must be removed prior to the application of new membrane. New membrane flashing must not conceal weep holes or cover existing through wall counterflashing.
2. Wall flashings shall extend above the anticipated slush line, above the roof surface, prior to written approval from Carlisle is required for lower heights of flashing.
3. Pre-fabricated accessories must be utilized, where applicable.
4. Project details must be reviewed by Carlisle, preferably prior to bid, and a written approval must be obtained. As a warranty prerequisite, the approval shall be included as part of the project submittals along with the Request for Warranty form that is required for project approval.
5. Only Carlisle supplied Sheet Metal and Edging is to be used on all projects, unless prior authorization from Carlisle has been obtained.
6. Carlisle Termination Bar is required in locations where a compression bar termination has been specified. The Termination Bar must be used in conjunction with new or existing counterflashing.
7. Where new or existing counterflashing is used, Carlisle's Termination Bar must be used as the primary termination.
8. Certain metal accessories by others may be permitted upon Carlisle acceptance for wind speed coverage less than 72 mph.

SECTION 7: DAILY PROCEDURES

Daily Seal

1. On phased roofing, when the completion of flashings and terminations is not possible by the end of each workday, provisions must be taken to temporarily close the membrane to prevent water infiltration.
2. Temporarily seal any loose membrane edge down slope using Flexible FAST Adhesive, hot asphalt, or a similar product so that the membrane edge will not buck water. Caution must be exercised to ensure positive draining during installation, temporary seal locations should be designated so that drainage is not restricted during construction by partially installed roof sections.
 - a. When applying Flexible FAST Adhesive or other sprayed urethane foam, prime the surface of the membrane with Carlisle Primer to ensure proper adhesion
3. When tie-in to existing built-up roofs, remove the gravel. The surface must be clean and dry.
4. After embedding membrane in daily seal material, CHECK FOR CONTINUOUS CONTACT. Provide continuous pressure over the length of the temporary seal. Provide weight evenly distributed along the length of the daily seal to reduce the wind effect on the continuous temporary seal.

Note: The use of rigid wood nailers is not recommended due to warping. Constant compression cannot be achieved on an uneven substrate.
5. When work is resumed, pull the imbedded membrane free; trim and remove daily seal material from membrane before continuing installation of adjoining sections.

Clean Up

1. If required by the specifier to ensure the aesthetics of the surface of the membrane, hand prints, footprints, general traffic grime, industrial pollutants and environmental dirt may be cleaned from the surface of the membrane by scrubbing with soapy (non-abrasive soap) water and rinsing the area completely with clean water.
 - a. For EPDM membranes, Weathered Membrane Cleaner can be used to clean the surface of the membrane.
2. Bonding Adhesive and Flexible FAST Adhesive residue may be cleaned by using the following procedures:
 - a. Saturate a clean HP Splice Wipe with Weathered Membrane Cleaner.
 - b. Scrub exposed adhesive with the saturated HP Splice Wipe until all residue is removed from the membrane. For easier removal, it may be necessary to change Splice Wipes frequently.

Inspection Process

1. Before roofing begins, an accurate design of the roof should be submitted into Carlisle's Project Review team to be reviewed. Once approved by Carlisle, the NOA (Notice of Award) will be given in return with a 7-digit job number. Roofing should then begin as scheduled.

NOTE: Please be aware of any special design specifications noted on NOA.
2. Once the roof is 100% completed per Carlisle Specifications, the NOC (Notice of Completion) is submitted into Carlisle, informing us the job is complete. Once this is submitted, within 24 hours, the job will be assigned to the appropriate Carlisle Field Service Representative (FSR) for that area.

NOTE: Please provide an accurate drawing and accurate address of the job.
3. The assigned Carlisle FSR will give roofer a 48-hour notice on when he/she would be able conduct a final inspection.

- The day of the final inspection, Carlisle would prefer the roofer to be present and roof access be provided.

NOTE: Having a crew present during the inspection helps with the inspection process by repairing any issues during the inspection.

- The inspection process begins as followed:

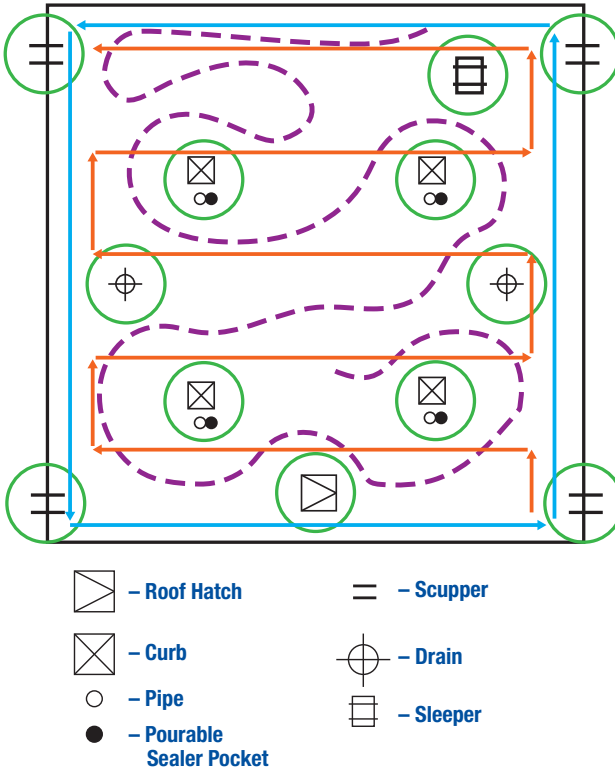

Step 1: Inspect the perimeter.

Update the roof plan to show the location of all curbs, penetrations, drains, etc. Focus on securement and termination. Mark deficiencies on the roof plan as they are found.

Step 2: Inspect all seams on the roof level.

Focus on plate placement and proper seaming.

Step 3: Inspect all curbs, penetrations, drains, etc.

Focus on one detail at a time, confirming proper securement, termination, and flashing minimums.

Step 4: Finally, walk across the roof, update areas in need of repair, and perform a general check of the system.

TABLE OF CONTENTS

Insulation Details.....	90
A-27A Carlisle Insulation / Cover Board Attachment	90
A-27B Minimum 2"-Thick Carlisle / InsulBase / SecurShield Polyisocyanurate Insulation	91
A-27C Minimum 1½"-Thick Carlisle / InsulBase / SecurShield Polyisocyanurate Insulation	92
A-27D ¼" - or ½"-Thick Securock or DensDeck Prime	93
A-27E ⅝"-Thick Securock or DensDeck Prime.....	94
A-27F Carlisle StormBase (OSB/Polyisocyanurate Composite Attachment.....	95
A-27G Insulation / Cover Board Attachment Using Bead Adhesive	96
MF-27 Insulation / Cover Board Attachment For All Warranty Durations	97
MF-27C R-Tech Fanfold Roof Underlayment.....	98
MF-27D R-Tech Fanfold Roof Underlayment for FM Assemblies	99
MF-27E Insulation/Coverboard Attachment when Using SecurShield Family Products for All Warranty Lengths.....	100
Main Details	101
Ballasted Details	
B-1A Carlisle SecurEdge 200	101
B-3A Deck-to-Deck Expansion Joint	102
Mechanically Fastened Details	
MF-1A SecurEdge 200.....	103
MF-2.1 Mechanically Fastened EPDM Securement- Option 1	104
MF-2.2 Mechanically Fastened EPDM Securement- Option 2 (RUSS)	105
MF-2.3 Mechanically Fastened EPDM Securement- Option 3 (RUSS)	106
MF-2A Mechanically Fastened EPDM Membrane Splice	107
MF-2A.1 Mechanically Fastened EPDM Membrane Splice (25/30 Year Warranties)	108
MF-2B Mechanically Fastened EPDM Membrane Splice Intersection	109
MF-2B.1 Mechanically Fastened EPDM Membrane Splice Intersection (25/30 Year Warranties)	110
MF-2D End Lap Splice	111
MF-6B Roof Drain with Sump.....	112
MF-8A Pressure-Sensitive Pipe Seal	113
MF-8A.1 Pressure-Sensitive Pipe Seal with 20" Pressure-Sensitive Cured Flashing	114
MF-8B Field Fabricated Pipe Wrap	115
MF-8B.1 Field Fabricated Pipe Wrap (25/30 Year Warranties)	116
MF-22 Ridge Membrane Attachment	117
Universal Details	
U-1A Carlisle SecurEdge 200	118
U-1A.1 Carlisle SecurEdge 200 (25/30 Year Warranties)	119
U-1B Carlisle SecurEdge 300.....	120
U-1B.1 Carlisle SecurEdge 300 (25/30 Year Warranties)	121
U-1C Carlisle SecurEdge 2000 & 3000.....	122
U-1D SecurEdge Drip Edge Fascia	123
U-1D.1 SecurEdge Drip Edge Fascia (25/30 Year Warranties)	124
U-1E SecurEdge One-Piece Gravel Stop	125
U-1F Metal Bar Edge Termination.....	126
U-2A EPDM Membrane Splice.....	127
U-2A.1 EPDM Membrane Splice (25/30 Year Warranties)	128
U-2B EPDM Membrane Splice Intersection.....	129
U-2B.1 EPDM Membrane Splice Intersection (90-mil Membrane or 25/30 Year Warranties)	130
U-2C EPDM Membrane Splices at Angle Change.....	131
U-3A Deck-to-Deck Expansion Joint	132
U-3B Deck-to-Wall Expansion Joint	133

U-3C Shear/Expansion Joint.....	134
U-5A Curb Flashing- EPDM Membrane	135
U-5B Curb Flashing- Pressure-Sensitive Curb Wrap with 6" Tape.....	136
U-5C Curb Flashing with 20" Pressure-Sensitive Cured Flashing.....	137
U-5D Self-Flashing Curb	138
U-5E New Self-Flashing Metal Curb	139
U-6A Roof Drain.....	140
U-6B Roof Drain- Reinforced Field Sheet with Sump Exceeding 3" per Foot	141
U-6C Sure-Seal Insert Drain.....	142
U-6D Insert Drain Through Deck	143
U-6E Sure-Seal Add-On Drain	144
U-8A Pressure-Sensitive Pipe Seal.....	145
U-8A.1 Pressure-Sensitive Pipe Seal (90-mil Membrane or 25/30 Year Warranties)	146
U-8B Field Fabricated Pipe Wrap	147
U-8B.1 Field Fabricated Pipe Wrap (25/30 Year Warranties)	148
U-8C Flexible Penetration.....	149
U-8C.1 Flexible Penetration (25/30 Year Warranties)	150
U-8D Field Fabricated Hot Stack	151
U-8D.1 Field Fabricated Hot Stack (25/30 Year Warranties)	152
U-9 Membrane Terminations (1 of 2)	153
U-9 Membrane Terminations (2 of 2).....	154
U-12A Parapet/Curb with Continuous Membrane	155
U-12B Parapet/Curb with Separate Membrane Flashing.....	156
U-13A Built-Up Roofing Tie-In Over Steel Roof Deck.....	157
U-13B Built-Up Roofing Tie-In Over Concrete Roof Deck	158
U-13C Tie-In to Existing EPDM Membrane	159
U-13D EPDM Tie-In Over Concrete Deck	160
U-13E Tie-In Shingled or Metal Panel Roof.....	161
U-13F Tie-In Between New Carlisle Adhered & Ballasted Roof.....	162
U-13G Tie-In Between New Carlisle Mechanically Fastened & Ballasted Roof.....	163
U-15A Inside Corner Wall Flashing with RUSS (Option 1)	164
U-15B Inside Corner Wall Flashing with RUSS (Option 2).....	165
U-15C Inside Corner with Continuous EPDM Wall Flashing	166
U-15D Inside Corner with Separate EPDM Wall Flashing.....	167
U-15D.1 Inside Corner Flashing (90-mil Membrane or 25/30 Year Warranties)	168
U-15E Outside Corner with Pre-Cut Pressure-Sensitive Corner.....	169
U-15F Outside Corner with Pressure-Sensitive Elastoform Flashing (2 Piece)	170
U-15G Outside Corner with Pressure-Sensitive Elastoform Flashing (1 Piece).....	171
U-15G.1 Outside Corner Flashing (90-mil Membrane or 25/30 Year Warranties)	172
U-16A Pressure-Sensitive Pourable Sealer Pocket.....	173
U-16A.1 Pressure-Sensitive Pourable Sealer Pocket (25/30 Year Warranties)	174
U-16B Field Fabricated Pourable Sealer Pocket.....	175
U-16B.1 Field Fabricated Pourable Sealer Pocket (25/30 Year Warranties)	176
U-16C Extended Pourable Sealer Pocket	177
U-16C.1 Extended Pourable Sealer Pocket (25/30 Year Warranties)	178
U-18A Metal Scupper at Deck.....	179
U-20A Lightning Rod at Parapet (Vertical Attachment).....	180
U-20B Lightning Rod at Deck Level.....	181
U-22 Valley	182
U-24 Sleeper	183
U-30 I-Beam Penetration	184
SAT Details	
SAT-2A SAT EPDM Membrane Splices.....	185
SAT-12A Parapet / Curb with Continuous Membrane- RUSS.....	186

SAT-12B Parapet / Curb with Separate Regular EPDM Flashing	187
SAT-12C Parapet / Curb with Separate SAT EPDM	188
SAT-12D Parapet / Curb with Continuous Membrane- Cover Strip	189
Liquid Flashing Details	190
Attachment 1- Inspection, Cleaning & Substrate Preparation (Page 1 of 2)	193
Attachment 1- Inspection, Cleaning & Substrate Preparation (Page 2 of 2)	194
Attachment 2- Application of LIQUISEAL Primer & Resin	195
LF-1.1 Sheet Metal Drip Edge or Gravel Stop Flashing	196
LF-8.1 Single or Multiple Pipe Penetrations (Page 1 of 2)	197
LF-8.1 Single or Multiple Pipe Penetrations (page 2 of 2)	198
LF-13.1 EPDM Membrane Tie-in with Existing Roof over Steel Deck	199
LF-13.2 TPO or PVC Membrane Tie-In With Existing Roof Over Steel Deck (1 of 2)	200
LF-13.2 TPO or PVC Membrane Tie-In With Existing Roof Over Steel Deck (2 of 2)	201
LF-13.3 Membrane Tie-in with Existing Roof over Concrete Deck	202
LF-18.1 Through-Wall Scupper	203
LF-30.1 Steel I-Beam Flashing (Page 1 of 2)	204
LF-30.1 Steel I-Beam Flashing (Page 2 of 2)	205
VacuSeal Details	206
V-0.1 Roof Assembly Over Existing Single-Ply Roof	206
V-0.2 Roof Assembly Over Existing Asphaltic Roof	207
V-0.3 Roof Assembly Over Steel Deck	208
V-0.4 Roof Assembly Over Poured-in-Place Concrete Deck	209
V-0.5 Roof Assembly Over Concrete Planks	210
V-0.6 Roof Assembly Over Lightweight Concrete Deck	211
V-0.7 Roof Assembly Over Wood Deck	212
V-1.1 Roof Edge: Roof Recover	213
V-1.2 Roof Edge: Tear-Off & Reroofing	214
V-5.1 Curb Base Flashing - New Construction and Re-Roof (Recover)	215
V-6.1 Roof Drain: Re-Roof (Recover)	216
V-6.2 Roof Drain: New Construction	217
V-8.0 VacuSeal Vent with Pre-Applied Skirt Flashing	218
V-8.1 Pipe/Structural Steel Tube Through Metal Deck	219
V-8.2 Multiple Penetrations Through Steel Deck - New Construction	220
V-8.3 Single Penetration Through Existing Roof Assembly	221
V-8.4 Cluster of Penetrations Through Existing Roof Assembly	222
V-8.5A Hot Stack Air Flashing - Option A	223
V-8.5B Hot Stack Air Flashing - Option B	224
V-12.1 Parapet with Membrane Air Barrier	225
V-12.2 Parapet/Curb: Concrete/Lightweight Concrete Used as an Air Barrier	226
V-12.3 Parapet or Wall - New Construction and Re-Roof (Recover)	227
Contact Information	228

SECTION 8: DETAILS

SPEC SUPPLEMENT INSULATION/ COVER BOARD

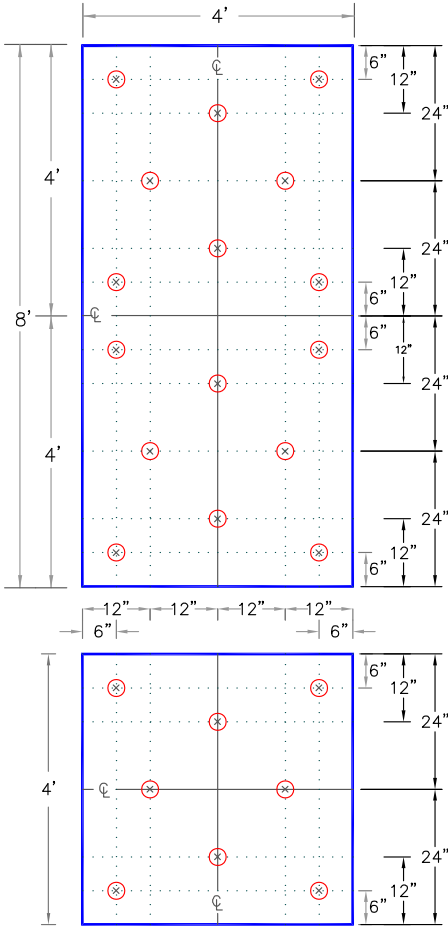

NOTES:

1. WHEN ENHANCED INSULATION FASTENING IS REQUIRED AS PRESCRIBED IN FACTORY MUTUAL LOSS PREVENTION DATA SHEET 1-29, ANSI/SPRI WD-1, OR MIAMI-DADE COUNTY, REFER TO [CARLISLE'S DESIGN REFERENCE DR-05-18](#).
2. FOR CRITERIA ON INSULATION FASTENERS AND PLATES, REFER TO CARLISLE SPECIFICATIONS.
3. IF A WIND SPEED WARRANTY GREATER THAN 55 MILES PER HOUR (25 METERS PER SECOND) OR A WARRANTY TERM GREATER THAN 20-YEARS IS SPECIFIED OR FOR SYSTEMS OVER 50'(15METERS), ADDITIONAL FASTENING MAY BE REQUIRED, REFER TO CARLISLE SPECIFICATIONS.

FEET TO CENTIMETERS		INCHES TO CENTIMETERS																				
4'	8'	inch	1/8"	1/4"	15/32"	1/2"	5/8"	3/4"	1"	1.5"	2"	2.5"	3"	4"	6"	8"	9"	11"	12"	18"	24"	36"
120	250	cm	0.5	1	1.2	1.5	1.6	2	2.5	4	5	6.5	7.5	10	15	20	23	28	30	46	61	91

⊗	FASTENER & PLATE
⊕	CENTER LINE
---	GUIDE LINE

CARLISLE INSULATION/ COVER BOARD ATTACHMENT

For additional information, refer to Specifications



DETAIL NO.
A-27A
ADHERED SYSTEM

SPEC SUPPLEMENT INSULATION/ COVER BOARD

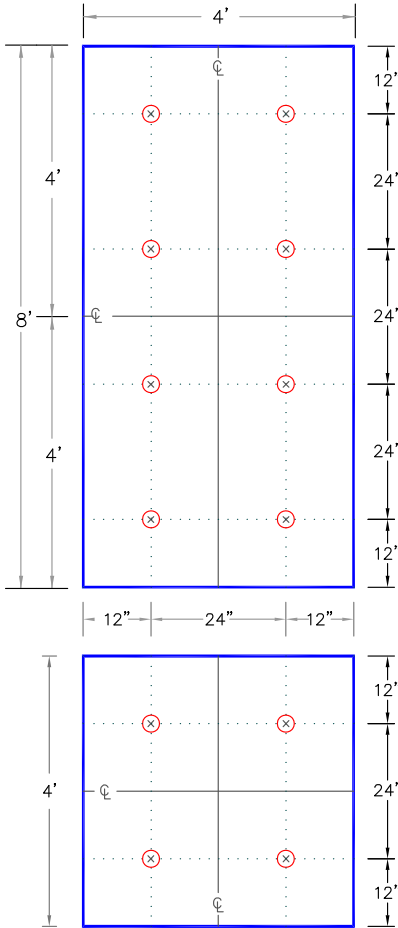

NOTES:

1. THIS DETAIL APPLIES TO MIN. 2" (51mm) THICK (SINGLE OR TOP LAYER) CARLISLE POLYISOCYANURATE INSULATION WHEN FASTENED INTO 22-GAUGE (0.8mm) STEEL, STRUCTURAL CONCRETE, MINIMUM 15/32" (12mm) PLYWOOD OR 1-1/2" (40mm) THICK WOOD PLANK ROOF DECKS.
2. WHEN ENHANCED INSULATION FASTENING IS REQUIRED AS PRESCRIBED IN FACTORY MUTUAL LOSS PREVENTION DATA SHEET 1-29, ANSI/SPRI WD-1 OR MIAMI-DADE COUNTY, REFER TO [CARLISLE'S DESIGN REFERENCE DR-05-18](#).
3. FOR CRITERIA ON INSULATION FASTENERS AND PLATES, REFER TO CARLISLE SPECIFICATIONS.
4. IF A WIND SPEED WARRANTY GREATER THAN 55 MILES PER HOUR (25 METERS PER SECOND) OR A WARRANTY TERM GREATER THAN 20-YEARS IS SPECIFIED OR FOR SYSTEMS OVER 50'(15METERS), ADDITIONAL FASTENING MAY BE REQUIRED, REFER TO CARLISLE SPECIFICATIONS.
5. DETAIL NOT FOR USE OVER ORIENTED STRAND BOARD, GYPSUM, CEMENTITIOUS WOOD FIBER (TECTUM), LIGHTWEIGHT INSULATING CONCRETE OR STEEL ROOF DECK THINNER THAN 22-GAUGE (0.8mm). [REFER TO DETAIL A-27A](#) FOR ACCEPTABLE FASTENING.

FEET TO CENTIMETERS	
4'	8'
120	250

INCHES TO CENTIMETERS																				
inch	1/8"	1/4"	15/32"	1/2"	5/8"	3/4"	1"	1.5"	2"	2.5"	3"	4"	6"	8"	9"	11"	12"	18"	24"	36"
cm	0.5	1	1.2	1.5	1.6	2	2.5	4	5	6.5	7.5	10	15	20	23	28	30	46	61	91

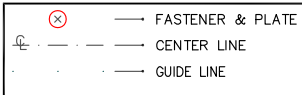

MINIMUM 2" THICK CARLISLE HP-H / INSULBASE / SECURSHIELD POLYISOCYANURATE INSULATION
For additional information, refer to Specifications



DETAIL NO. A-27B
ADHERED SYSTEM

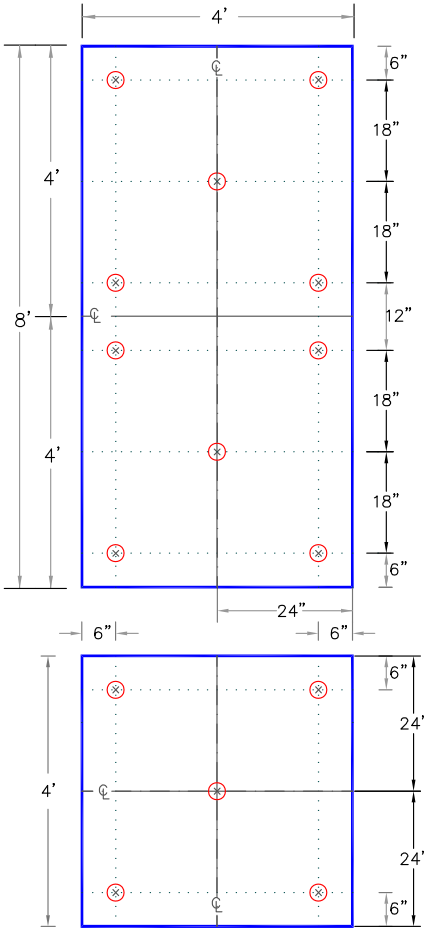

NOTES:

1. THIS DETAIL APPLIES TO MIN. 1-1/2" (40mm) THICK (SINGLE OR TOP LAYER) CARLISLE POLYISOCYANURATE INSULATION WHEN FASTENED INTO 22-GAUGE (0.8mm) STEEL, STRUCTURAL CONCRETE, MINIMUM 15/32" (12mm) PLYWOOD OR 1-1/2" (40mm) THICK WOOD PLANK ROOF DECKS.
2. WHEN ENHANCED INSULATION FASTENING IS REQUIRED AS PRESCRIBED IN FACTORY MUTUAL LOSS PREVENTION DATA SHEET 1-29, ANSI/SPRI WD-1 OR [CARLISLE'S DESIGN REFERENCE DR-05-18](#).
3. FOR CRITERIA ON INSULATION FASTENERS AND PLATES, REFER TO CARLISLE SPECIFICATIONS.
4. IF A WIND SPEED WARRANTY GREATER THAN 55 MILES PER HOUR (25 METERS PER SECOND) OR A WARRANTY TERM GREATER THAN 20-YEARS IS SPECIFIED OR FOR SYSTEMS OVER 50' (15 METERS), ADDITIONAL FASTENING MAY BE REQUIRED, REFER TO CARLISLE SPECIFICATIONS.
5. THIS DETAIL NOT FOR USE OVER ORIENTED STRAND BOARD, GYPSUM, FIBROUS CEMENT (TECTUM), LIGHTWEIGHT INSULATING CONCRETE OR STEEL ROOF DECK THINNER THAN 22-GAUGE (0.8mm). [REFER TO DETAIL A-27.1](#) FOR ACCEPTABLE FASTENING.

FEET TO CENTIMETERS		INCHES TO CENTIMETERS																				
4'	8'	inch	1/8"	1/4"	5/32"	1/2"	5/8"	3/4"	1"	1.5"	2"	2.5"	3"	4"	6"	8"	9"	11"	12"	18"	24"	36"
120	250	cm	0.5	1	1.2	1.5	1.6	2	2.5	4	5	6.5	7.5	10	15	20	23	28	30	46	61	91

⊗	FASTENER & PLATE	MINIMUM 1-1/2" THICK CARLISLE HP-H / INSULBASE / SECURSHIELD POLYISOCYANURATE INSULATION For additional information, refer to Specifications		DETAIL NO.
⊕	CENTER LINE			A-27C
---	GUIDE LINE			ADHERED SYSTEM

SPEC SUPPLEMENT INSULATION / COVER BOARD

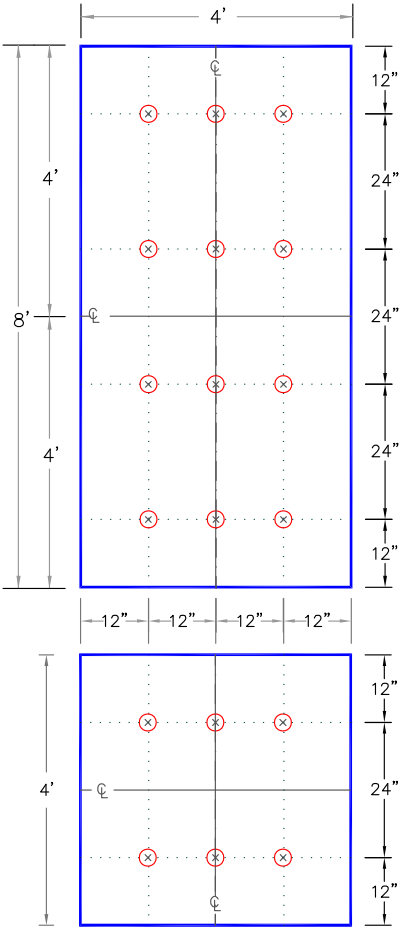

NOTES:

- THIS DETAIL APPLIES TO 1/4" (10mm) AND 1/2" (15mm) THICK SECUROCK OR DENS DECK PRIME (OVER AN APPROVED INSULATION) WHEN FASTENED INTO 22-GAUGE (0.8mm) STEEL, STRUCTURAL CONCRETE, MINIMUM 15/32" (12mm) PLYWOOD OR 1-1/2"(40mm) THICK WOOD PLANK ROOF DECKS.
- WHEN ENHANCED FASTENING IS REQUIRED AS PRESCRIBED IN FACTORY MUTUAL LOSS PREVENTION DATA SHEET 1-29, ANSI/SPRI WD-1 OR MIAMI-DADE COUNTY, REFER TO [CARLISLE'S DESIGN REFERENCE DR-05-1B](#).
- FOR CRITERIA ON INSULATION FASTENERS AND PLATES, REFER TO CARLISLE SPECIFICATIONS.
- IF A WIND SPEED WARRANTY GREATER THAN 55 MILES PER HOUR (25 METERS PER SECOND) OR A WARRANTY TERM GREATER THAN 20-YEARS IS SPECIFIED OR FOR SYSTEMS OVER 50'(15METERS), ADDITIONAL FASTENING MAY BE REQUIRED, REFER TO CARLISLE SPECIFICATIONS.
- DETAIL NOT FOR USE OVER ORIENTED STRAND BOARD, GYPSUM, FIBROUS CEMENT (TECTUM), LIGHTWEIGHT INSULATING CONCRETE OR STEEL ROOF DECK LESS THAN 22-GAUGE (0.8mm), [REFER TO DETAIL A-27.1](#) FOR ACCEPTABLE FASTENING.
- WHEN INSTALLED OVER COMBUSTIBLE WOOD DECKS OR INSULATIONS, ALL JOINTS SHALL BE STAGGERED.
- LONG UNINTERRUPTED RUNS GREATER THAN 200' (>61 METERS) OF SECUROCK MAY REQUIRE SLIGHT GAPPING DUE TO THERMAL EXPANSION.

FEET TO CENTIMETERS		INCHES TO CENTIMETERS																				
4'	8'	inch	1/8"	1/4"	15/32"	1/2"	5/8"	3/4"	1"	1.5"	2"	2.5"	3"	4"	6"	8"	9"	11"	12"	18"	24"	36"
120	250	cm	0.5	1	1.2	1.5	1.6	2	2.5	4	5	6.5	7.5	10	15	20	23	28	30	46	61	91

FASTENER & PLATE CENTER LINE GUIDE LINE	1/4" OR 1/2" THICK SECUROCK OR DENS DECK PRIME		DETAIL NO.
	For additional information, refer to Specifications		A-27D ADHERED SYSTEM

© 2023 Carlisle SynTec a division of Carlisle Construction Materials Incorporated

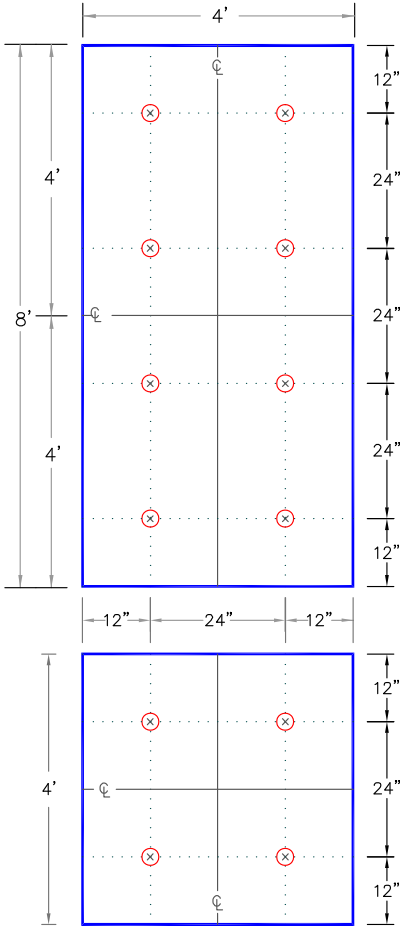

NOTES:

1. THIS DETAIL APPLIES TO 5/8" (16mm) THICK SECUROCK, DENS DECK PRIME, DENS DECK STORMX PRIME OR STORMBASE POLYISO (OVER AN APPROVED INSULATION) WHEN FASTENED INTO 22-GAUGE STEEL, STRUCTURAL CONCRETE, MINIMUM 15/32" (12mm) PLYWOOD OR 1-1/2" (40mm) THICK WOOD PLANK ROOF DECKS.
2. WHEN ENHANCED FASTENING IS REQUIRED AS PRESCRIBED IN FACTORY MUTUAL LOSS PREVENTION DATA SHEET 1-29, ANSI/SPRI WD-1 OR MIAMI-DADE COUNTY, REFER TO [CARLISLE'S DESIGN REFERENCE DR-05-18](#).
3. FOR CRITERIA ON INSULATION FASTENERS AND PLATES, REFER TO CARLISLE SPECIFICATIONS.
4. IF A WIND SPEED WARRANTY GREATER THAN 55 MILES PER HOUR (25 METERS PER SECOND) OR A WARRANTY TERM GREATER THAN 20-YEARS IS SPECIFIED OR FOR SYSTEMS OVER 50' (15 METERS), ADDITIONAL FASTENING MAY BE REQUIRED, REFER TO CARLISLE SPECIFICATIONS.
5. DETAIL NOT FOR USE OVER ORIENTED STRAND BOARD, GYPSUM, FIBROUS CEMENT (TECTUM), LIGHTWEIGHT INSULATING CONCRETE OR STEEL ROOF DECK LESS THAN 22-GAUGE (0.8mm), [REFER TO DETAIL A-27.1](#) FOR ACCEPTABLE FASTENING.
6. WHEN INSTALLED OVER COMBUSTIBLE WOOD DECKS OR INSULATIONS, ALL JOINTS SHALL BE STAGGERED.
7. LONG UNINTERRUPTED RUNS GREATER THAN 200' (> 61M) OF SECUROCK MAY REQUIRE SLIGHT GAPPING DUE TO THERMAL EXPANSION.
8. STORMBASE POLYISO ACHIEVES UP TO A 20-YEAR, 90-MPH WARRANTY WITH (8) FASTENERS.

FEET TO CENTIMETERS		INCHES TO CENTIMETERS																				
4'	8'	inch	1/8"	1/4"	5/32"	1/2"	5/8"	3/4"	1"	1.5"	2"	2.5"	3"	4"	6"	8"	9"	11"	12"	18"	24"	36"
120	250	cm	0.5	1	1.2	1.5	1.6	2	2.5	4	5	6.5	7.5	10	15	20	23	28	30	46	61	91

⊗	FASTENER & PLATE	5/8" THICK SECUROCK, DENS DECK PRIME DENS DECK STORMX PRIME OR STORMBASE POLYISO		Ⓞ	CENTER LINE	DETAIL NO. A-27E
---	GUIDE LINE			---	ADHERED SYSTEM	
		For additional information, refer to Specifications				

SPEC SUPPLEMENT INSULATION/ COVER BOARD

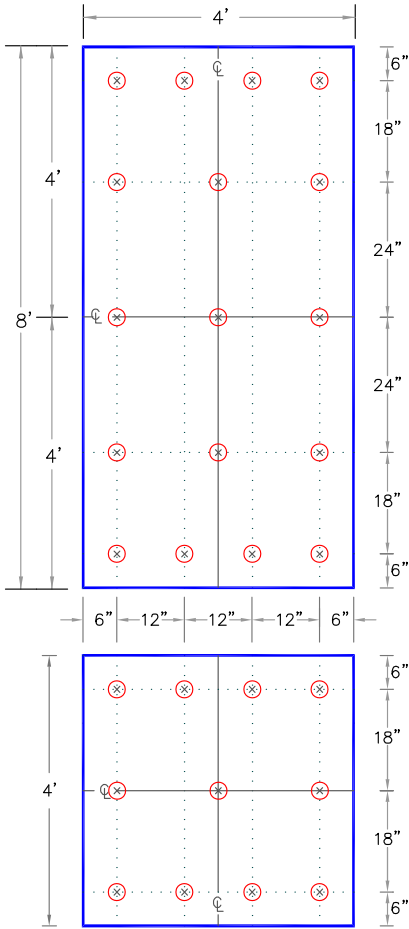

NOTES:

1. WHEN ENHANCED FASTENING IS REQUIRED AS PRESCRIBED IN FACTORY MUTUAL LOSS PREVENTION DATA SHEET 1-29, ANSI/SPRI WD-1 OR MIAMI-DADE COUNTY, REFER TO [CARLISLE'S DESIGN REFERENCE DR-05-18](#).
2. FOR CRITERIA ON INSULATION FASTENERS AND PLATES, REFER TO CARLISLE SPECIFICATIONS.
3. IF A WIND SPEED WARRANTY GREATER THAN 55 MILES PER HOUR (25 METERS PER SECOND) OR A WARRANTY TERM GREATER THAN 20-YEARS IS SPECIFIED OR FOR SYSTEMS OVER 50'(15METERS), ADDITIONAL FASTENING MAY BE REQUIRED, REFER TO CARLISLE SPECIFICATIONS.
4. OSB (ORIENTED STRAND BOARD) MUST BE POSITIONED WITH AN 1/8" (0.5m) GAP BETWEEN BOARDS.
5. WHEN SPECIFIED, JOINTS IN OSB (ORIENTED STRAND BOARD) MUST BE STAGGERED WITH JOINTS IN INSULATION BELOW.

FEET TO CENTIMETERS		INCHES TO CENTIMETERS																				
4'	8'	inch	1/8"	1/4"	5/32"	1/2"	5/8"	3/4"	1"	1.5"	2"	2.5"	3"	4"	6"	8"	9"	11"	12"	18"	24"	36"
120	250	cm	0.5	1	1.2	1.5	1.6	2	2.5	4	5	6.5	7.5	10	15	20	23	28	30	46	61	91

	FASTENER & PLATE CENTER LINE GUIDE LINE		DETAIL NO. A-27F
	OSB SHEATHING ATTACHMENT For additional information, refer to Specifications		

© 2023 Carlisle SynTec a division of Carlisle Construction Materials Incorporated

ATTACHMENT DETAILS INSULATION/ COVER BOARD

NOTES:

- REFER TO CARLISLE SPECIFICATIONS FOR PRODUCT DATA SHEETS FOR APPROPRIATE BEAD SPACING BASED UPON THE BUILDING HEIGHT, WARRANTY TERM AND ACCEPTABLE SUBSTRATE.
- THE SURFACE TO WHICH ADHESIVE IS TO BE APPLIED SHALL BE DRY, FREE OF FINIS, PROTRUSIONS, SHARP EDGES, LOOSE AND FOREIGN MATERIALS, OIL AND GREASE. AREA SHOULD BE CLEANED WITH AN AIR BLOWER.
- PREVIOUSLY UNEXPOSED ASPHALT OR RESIDUE MUST BE PRIMED WITH CARLISLE CAVGRIP III, 702 OR 702LV PRIMER.
- SEAL ALL GAPS IN THE CONCRETE DECK WITH CARLISLE 725TR OR OTHER SUITABLE MATERIAL TO AVOID CONDENSATION ISSUES OR FILL WITH CARLISLE INSULATION ADHESIVE.
- AT THE BEGINNING OF THE INSULATION ATTACHMENT PROCESS AND PERIODICALLY THROUGHOUT THE DAY, CHECK THE ADHESION OF BOARDS TO ENSURE A TIGHT BOND IS CREATED AND MAXIMUM CONTACT IS ACHIEVED.
- WALK THE BOARDS INTO THE ADHESIVE AND ROLL USING A 30" WIDE, 150 POUND SEGMENTED STEEL ROLLER TO ENSURE FULL EMBEDMENT.
- ONE PERSON SHOULD BE DESIGNATED TO WALK AND ROLL IN ALL BOARDS. RELIEF CUTS MAY BE NECESSARY TO ALLOW LIFTED BOARD TO LAY FLAT OR CONSTANT WEIGHT (10LBS MINIMUM FOR 5-15 MINUTES PER LIFTED AREA) MAY BE NECESSARY TO ACHIEVE ADEQUATE ADHESION.

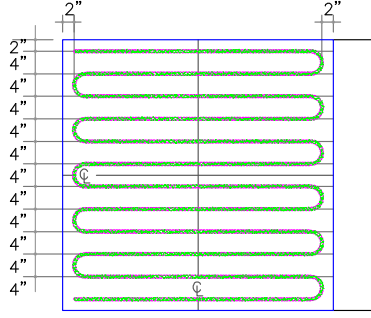
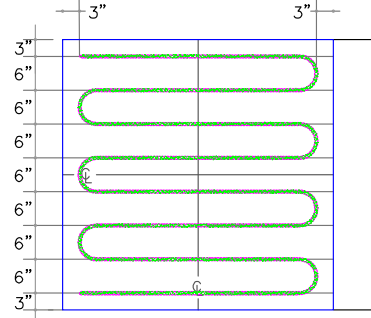
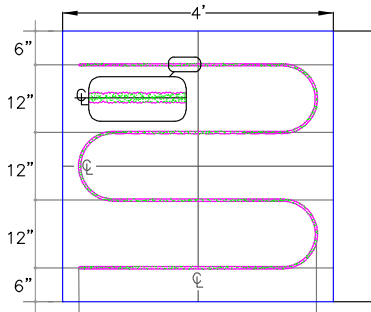

FEET TO CENTIMETERS		INCHES TO CENTIMETERS																				
4'	8'	inch	1/8"	1/4"	15/32"	1/2"	5/8"	3/4"	1"	1.5"	2"	2.5"	3"	4"	6"	8"	9"	11"	12"	18"	24"	36"
120	250	cm	0.5	1	1.2	1.5	1.6	2	2.5	4	5	6.5	7.5	10	15	20	23	28	30	46	61	91

FASTENER & PLATE CENTER LINE GUIDE LINE FOAM ADHESIVE	INSULATION/COVER BOARD ATTACHMENT USING BEAD ADHESIVE For additional information, refer to Specifications		DETAIL NO. A-27G ADHERED SYSTEM
--	--	--	--

ATTACHMENT DETAILS

INSULATION/ COVER BOARD

NEW CONSTRUCTION OR RE-ROOF/TEAR OFF PROJECTS WITH SECUROCK, DENS-DECK, HP RECOVERY BROAD OR ANY CARLISLE APPROVED INSULATION MIN 1-1/2" (40mm) THICK

RE-ROOF/NO TEAR OFF PROJECTS WITH POLYISOCYANURATE LESS THAN 1-1/2" (40mm) THICK

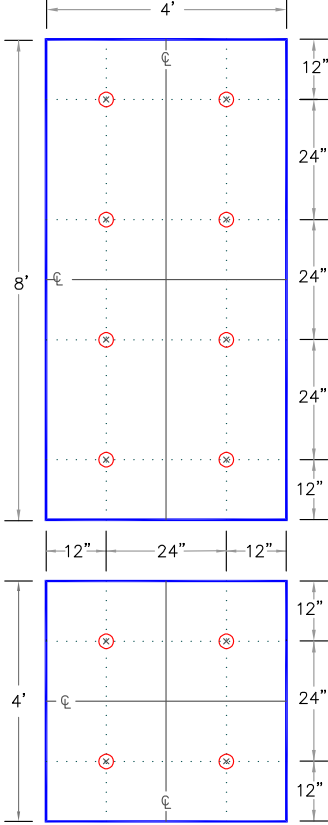
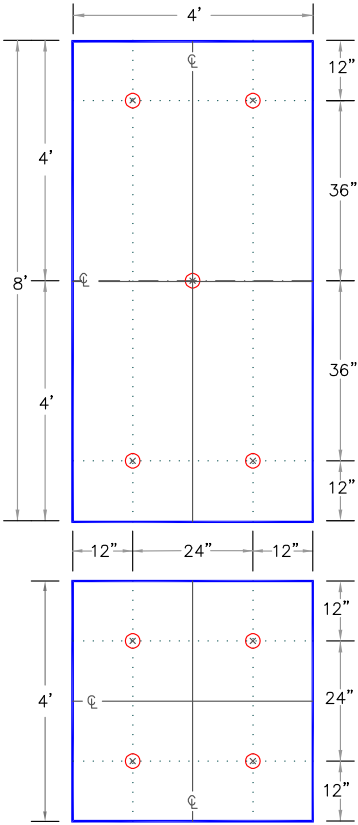

NOTES:

- FOR CRITERIA ON INSULATION FASTENERS AND PLATES, REFER TO CARLISLE SPECIFICATIONS.
- 25 AND 30-YEAR WARRANTY PROJECTS REQUIRE COMPLETE TEAR OFF.

FEET TO CENTIMETERS		INCHES TO CENTIMETERS																				
4'	8'	inch	1/8"	1/4"	5/32"	1/2"	5/8"	3/4"	1"	1.5"	2"	2.5"	3"	4"	6"	8"	9"	11"	12"	18"	24"	36"
120	250	cm	0.5	1	1.2	1.5	1.6	2	2.5	4	5	6.5	7.5	10	15	20	23	28	30	46	61	91

	<p>— FASTENER & PLATE</p> <p>— CENTER LINE</p> <p>— GUIDE LINE</p> <p>— FOAM ADHESIVE</p>	<p>INSULATION/COVER BOARD ATTACHMENT FOR ALL WARRANTY DURATIONS</p> <p>For additional information, refer to Specifications</p>	<p>DETAIL NO. MF-27</p> <p>MECHANICALLY FASTENED</p>
--	---	---	--

ATTACHMENT DETAILS INSULATION/ COVER BOARD

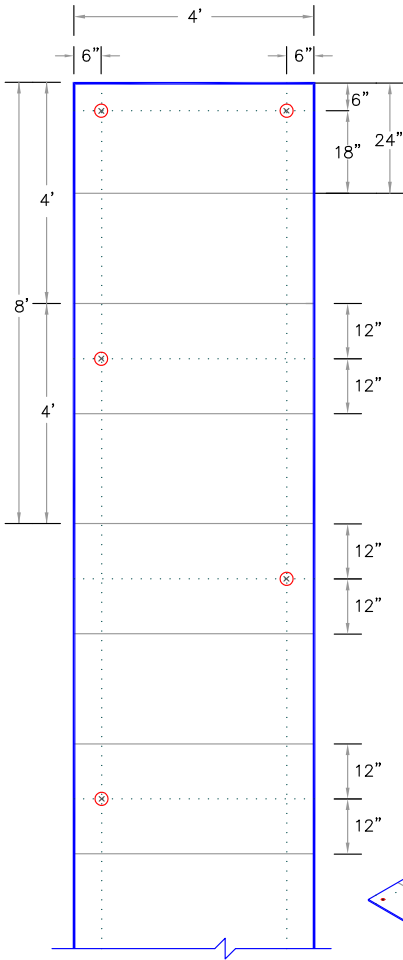

NOTES:

1. INSTALL R-TECH RECOVER BOARD WITH CONTINUOUS SIDE JOINTS AND END JOINTS STAGGERED SO THEY ARE OFFSET BY A MINIMUM OF 12" (30cm) FROM THE END JOINTS IN ADJACENT ROWS.
2. INSULATION SHOULD ABUT TIGHTLY AGAINST ADJACENT BOARDS.
3. IF R-TECH FANFOLD RECOVER BOARD IS BEING INSTALLED OVER AN EXISTING LAYER OF INSULATION, ALL JOINTS MUST BE OFFSET A MINIMUM OF 6" (15cm) BETWEEN LAYERS.
4. FASTENERS SHOULD NEVER BE CLOSER THAN 6" (15cm) FROM THE EDGES OF THE BOARD.
5. CARE MUST BE TAKEN TO AVOID OVERDRIVING OR UNDER-DRIVING THE FASTENER AND PLATE ASSEMBLY.
6. METALLIC FACER PERMITS THE USE OF R-TECH RECOVER BOARD UNDER EPDM MECHANICALLY FASTENED ASSEMBLIES IN NORTHERN CLIMATES (CONTACT CARLISLE FOR ACCEPTANCE).

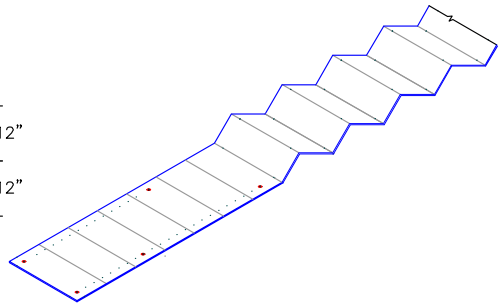

FEET TO CENTIMETERS		INCHES TO CENTIMETERS																				
4'	8'	inch	1/8"	1/4"	5/32"	1/2"	5/8"	3/4"	1"	1.5"	2"	2.5"	3"	4"	6"	8"	9"	11"	12"	18"	24"	36"
120	250	cm	0.5	1	1.2	1.5	1.6	2	2.5	4	5	6.5	7.5	10	15	20	23	28	30	46	61	91

FASTENER & PLATE CENTER LINE GUIDE LINE FOAM ADHESIVE	R-Tech FANFOLD ROOF UNDERLAYMENT For additional information, refer to Specifications		DETAIL NO. MF-27C MECHANICALLY FASTENED
--	---	--	--

© 2023 Carlisle SynTec a division of Carlisle Construction Materials Incorporated

ATTACHMENT DETAILS INSULATION/ COVER BOARD

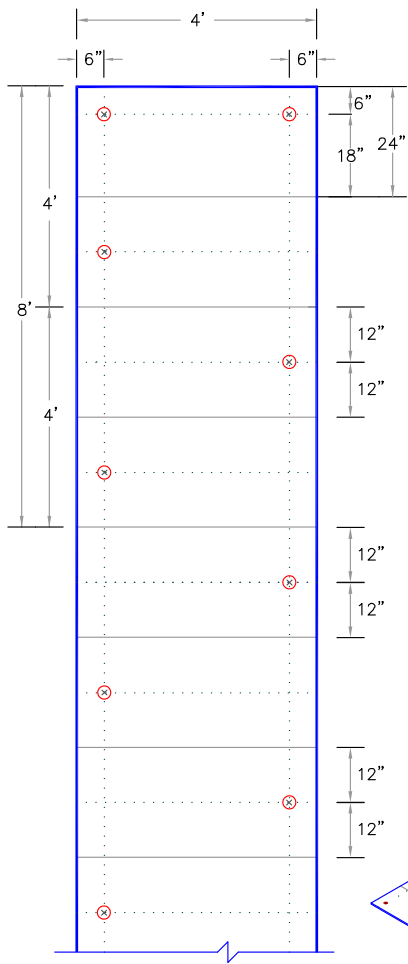

NOTES:

1. INSTALL R-TECH RECOVER BOARD WITH CONTINUOUS SIDE JOINTS AND END JOINTS STAGGERED SO THEY ARE OFFSET BY A MINIMUM OF 12" (30cm) FROM THE END JOINTS IN ADJACENT ROWS.
2. INSULATION SHOULD ABUT TIGHTLY AGAINST ADJACENT BOARDS.
3. IF R-TECH FANFOLD RECOVER BOARD IS BEING INSTALLED OVER AN EXISTING LAYER OF INSULATION, ALL JOINTS MUST BE OFFSET A MINIMUM OF 6" (15cm) BETWEEN LAYERS.
4. FASTENERS SHOULD NEVER BE CLOSER THAN 6" (15cm) FROM THE EDGES OF THE BOARD.
5. CARE MUST BE TAKEN TO AVOID OVERDRIVING OR UNDER-DRIVING THE FASTENER AND PLATE ASSEMBLY.
6. METALLIC FACER PERMITS THE USE OF R-TECH RECOVER BOARD UNDER EPDM MECHANICALLY FASTENED ASSEMBLIES IN NORTHERN CLIMATES (CONTACT CARLISLE FOR ACCEPTANCE).
7. FOR NON-FM ASSEMBLY REFER TO DETAIL MF-27C

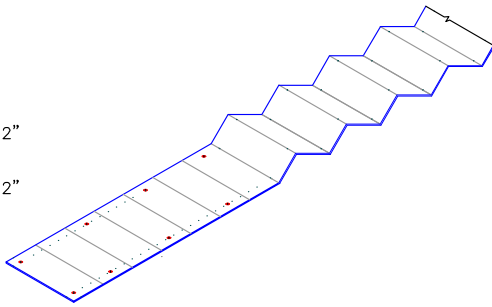

FEET TO CENTIMETERS		INCHES TO CENTIMETERS																				
4'	8'	inch	1/8"	1/4"	5/32"	1/2"	5/8"	3/4"	1"	1.5"	2"	2.5"	3"	4"	6"	8"	9"	11"	12"	18"	24"	36"
120	250	cm	0.5	1	1.2	1.5	1.6	2	2.5	4	5	6.5	7.5	10	15	20	23	28	30	46	61	91

	<p>FASTENER & PLATE</p> <p>CENTER LINE</p> <p>GUIDE LINE</p> <p>FOAM ADHESIVE</p>	<p>R-Tech FANFOLD ROOF UNDERLAYMENT FOR FM ASSEMBLIES</p> <p>For additional information, refer to Specifications</p>	<p>DETAIL NO.</p> <p>MF-27D</p> <p>MECHANICALLY FASTENED</p>
--	---	--	---

ATTACHMENT DETAILS INSULATION/ COVER BOARD

NEW CONSTRUCTION OR RE-ROOF/TEAR OFF PROJECTS WITH 1/2" SecurShield HD COATED GLASS FACER

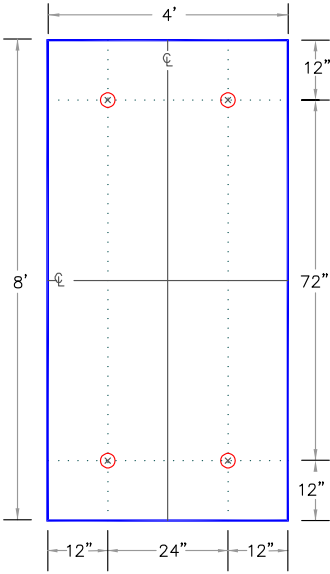

NEW CONSTRUCTION OR RE-ROOF/TEAR OFF PROJECTS WITH 20 OR 25 PSI SecurShield ANY THICKNESS

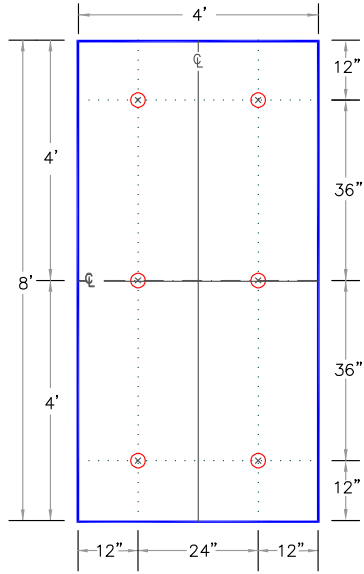

FEET TO CENTIMETERS		INCHES TO CENTIMETERS																				
4'	8'	inch	1/8"	1/4"	15/32"	1/2"	5/8"	3/4"	1"	1.5"	2"	2.5"	3"	4"	6"	8"	9"	11"	12"	18"	24"	36"
120	250	cm	0.5	1	1.2	1.5	1.6	2	2.5	4	5	6.5	7.5	10	15	20	23	28	30	46	61	91

 FASTENER & PLATE  CENTER LINE  GUIDE LINE  FOAM ADHESIVE	<p>INSULATION/COVERBOARD ATTACHMENT WHEN USING SecurShield FAMILY PRODUCTS FOR ALL WARRANTIES LENGTHS</p> <p>For additional information, refer to Specifications</p>		DETAIL NO. MF-27E MECHANICALLY FASTENED
--	--	---	--

© 2023 Carlisle SynTec a division of Carlisle Construction Materials Incorporated

THERMOSET MEMBRANE

EPDM

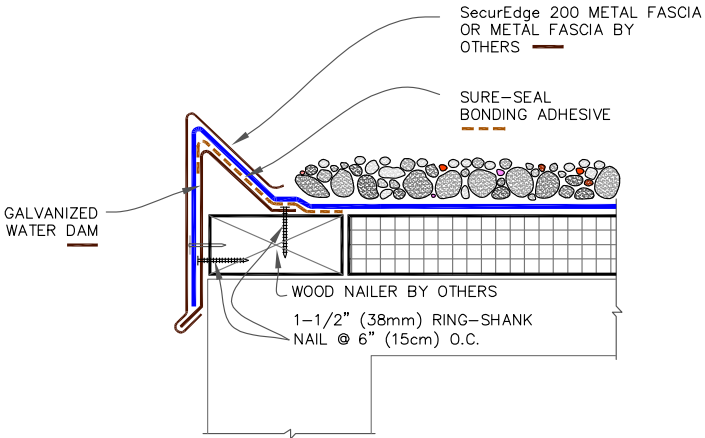

NOTE:

1. MAXIMUM MEMBRANE THICKNESS GOING OVER THE WATER DAM IS 60-MIL. FOR THICKER MEMBRANES, RUN FIELD SHEET UNDER THE WATER DAM AND STRIP-IN WITH MAXIMUM 60-MIL MEMBRANE.

DIMENSION	cm	
(A)	3"	7.5 MIN.

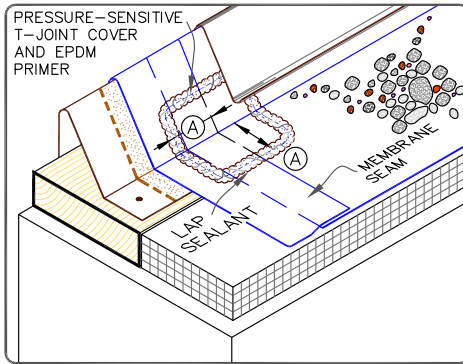

	CARLISLE SecurEdge 200		DETAIL NO.
	MAXIMUM WARRANTY: 20 YEARS		B-1A
		THERMOSET UNIVERSAL	

© 2023 Carlisle SynTec a division of Carlisle Construction Materials Incorporated

■■■■ THERMOSET MEMBRANE ■■■■ EPDM ■■■■

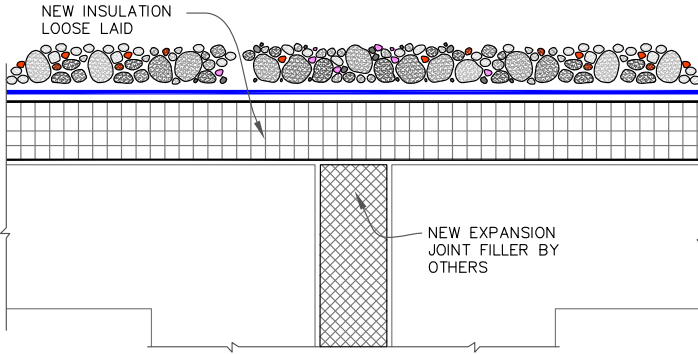

(A) NEW CONSTRUCTION OR TEAROFF

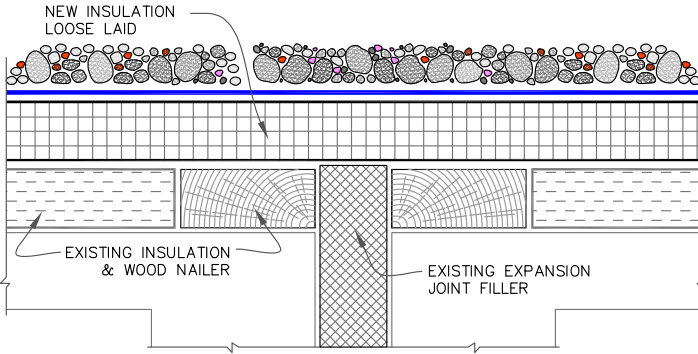

(B) DECK LEVEL/REROOFING

NOTE:

ANY [U-3 EXPANSION JOINT](#) DETAIL CAN BE USED WITH THE "B" SYSTEM (BALLASTED STONE ASSEMBLY)

	DECK-TO-DECK EXPANSION JOINT		DETAIL NO.
	MAXIMUM WARRANTY: 30 YEARS		B-3A
		THERMOSET UNIVERSAL	

© 2023 Carlisle SynTec a division of Carlisle Construction Materials Incorporated

THERMOSET MEMBRANE

EPDM

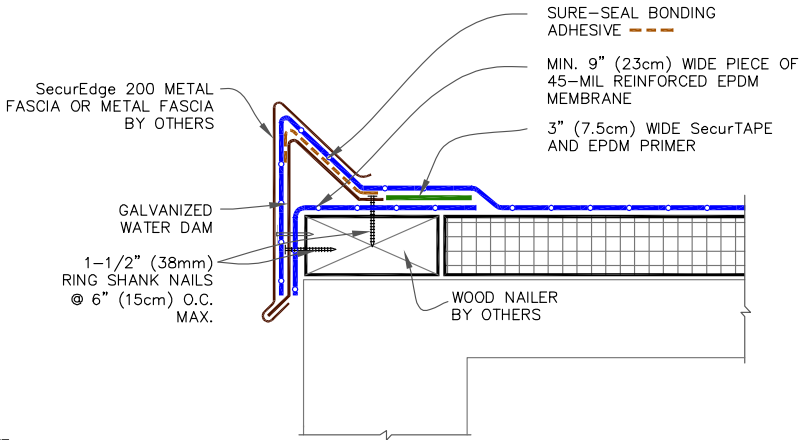

NOTE:

1. MAXIMUM MEMBRANE THICKNESS GOING OVER THE WATER DAM IS 60-MIL. FOR THICKER MEMBRANES, RUN FIELD SHEET UNDER THE WATER DAM AND STRIP-IN WITH MAXIMUM 60-MIL MEMBRANE.

DIMENSION	cm	
(A)	3"	7.5 MIN.

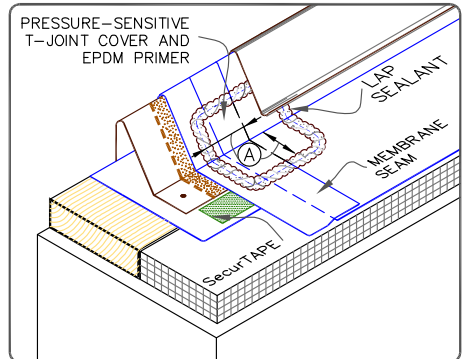

	CARLISLE SecurEdge 200	DETAIL NO. MF-1A
	MAXIMUM WARRANTY: 30 YEARS	

© 2023 Carlisle SynTec a division of Carlisle Construction Materials Incorporated

GUIDELINES FOR ROOF PERIMETER ZONES FOR MECHANICALLY ATTACHED ROOF SYSTEM

 PERIMETER ZONES

SPLIT LEVEL ROOFS

UPPER ROOF
LOWER ROOF
GREATER THAN 10 FT (3m)

SPLIT LEVEL ROOFS

UPPER ROOF
LOWER ROOF
LESS THAN 10 FT (3m)

CANOPY ROOF

ROOF FIELD
INSTALL PERIMETER SHEETS OVER THE ENTIRE OVERHANG AREA, EXTENDING ONTO THE MAIN ROOF DECK WHEN AT THE SAME LEVEL AS SHOWN.

LARGE OPENINGS OR LOADING DOCKS

④ ③ ② ①
C.L. W A.S. EQ. W
EQ. W
C.L. W

4 PERIMETER SHEETS CENTERED OVER LARGE OPENINGS

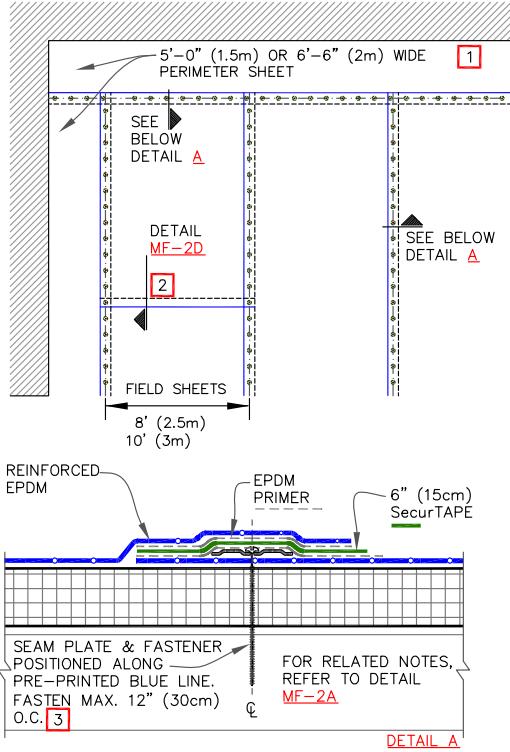

NOTES:

1. REFER TO CARLISLE SPECIFICATIONS FOR REQUIRED NUMBER OF PERIMETER SHEETS, SHEET WIDTH AND MEMBRANE FASTENING DENSITY.
2. END LAPS DO NOT REQUIRE MECHANICAL FASTENING AND SHALL BE SPLICED USING EITHER 3" (7.5cm) OR 6" (15cm) WIDE SecurTAPE. PER DETAIL MF-2D.
3. HP FASTENERS AND POLYMER SEAM PLATES ARE REQUIRED OVER STEEL DECKS.

	MECHANICALLY FASTENED EPDM SECUREMENT – OPTION 1	 DETAIL NO. MF-2.1
	MAXIMUM WARRANTY: 30 YEARS	

THERMOSET MEMBRANE

EPDM

GUIDELINES FOR ROOF PERIMETER ZONES FOR MECHANICALLY ATTACHED ROOF SYSTEM

 PERIMETER ZONES

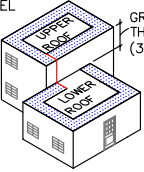
SPLIT LEVEL ROOFS
 GREATER THAN 10 FT (3m)

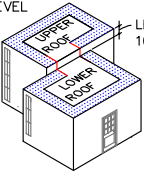
SPLIT LEVEL ROOFS
 LESS THAN 10 FT (3m)

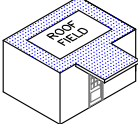
CANOPY ROOF
 INSTALL PERIMETER SHEETS OVER THE ENTIRE OVERHANG AREA, EXTENDING ONTO THE MAIN ROOF DECK WHEN AT THE SAME LEVEL AS SHOWN.

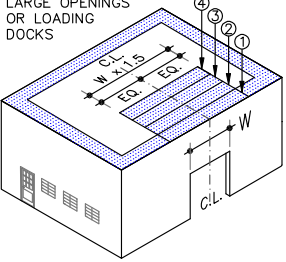
LARGE OPENINGS OR LOADING DOCKS

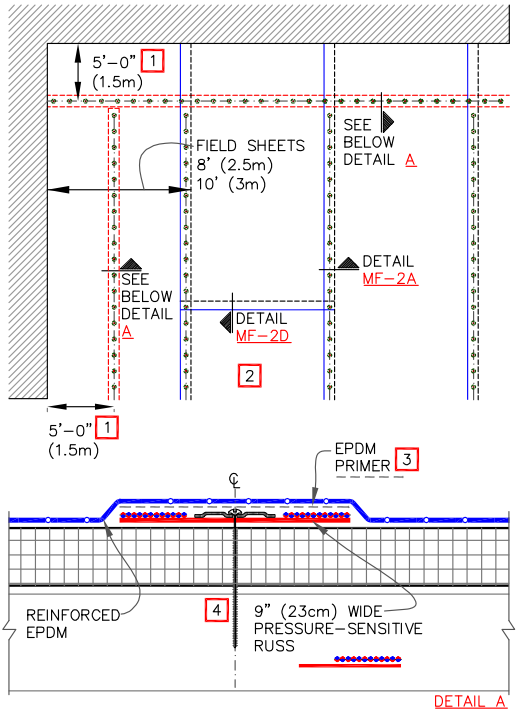
 4 PERIMETER SHEETS CENTERED OVER LARGE OPENINGS



NOTES:

1. REFER TO CARLISLE SPECIFICATIONS FOR REQUIRED NUMBER OF PERIMETER SHEETS, SHEET WIDTH AND MEMBRANE FASTENING DENSITY.
2. END LAPS DO NOT REQUIRE MECHANICAL FASTENING AND SHALL BE SPLICED USING EITHER 3" (7.5cm) OR 6" (15cm) WIDE SecurTAPE. PER DETAIL MF-2D.
3. EPDM PRIMER MUST BE APPLIED TO THE BACK SIDE OF MEMBRANE SURFACE PRIOR TO ADHERING MEMBRANE TO PRESSURE-SENSITIVE RUSS.
4. HP FASTENERS AND POLYMER SEAM PLATES ARE REQUIRED OVER STEEL DECKS.

	MECHANICALLY FASTENED EPDM SECUREMENT – OPTION 2 (RUSS)	 DETAIL NO. MF-2.2
	MAXIMUM WARRANTY: 30 YEARS	

GUIDELINES FOR ROOF PERIMETER ZONES FOR MECHANICALLY ATTACHED ROOF SYSTEM

 PERIMETER ZONES

SPLIT LEVEL ROOFS

GREATER THAN 10 FT (3m)

LESS THAN 10 FT (3m)

CANOPY ROOF

INSTALL PERIMETER SHEETS OVER THE ENTIRE OVERHANG AREA, EXTENDING ONTO THE MAIN ROOF DECK WHEN AT THE SAME LEVEL AS SHOWN.

LARGE OPENINGS OR LOADING DOCKS

4 PERIMETER SHEETS CENTERED OVER LARGE OPENINGS

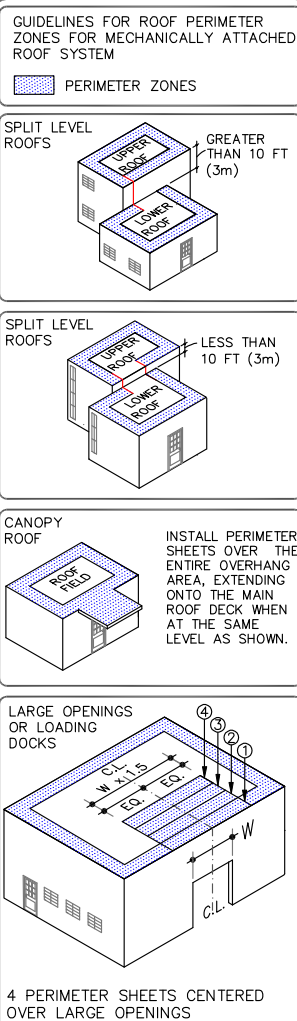
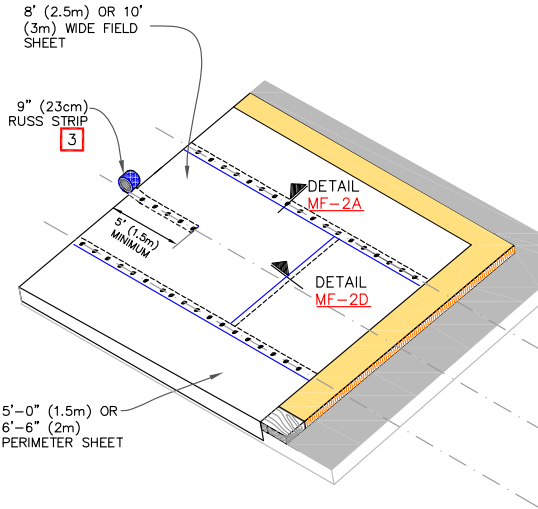
NOTES:

1. REFER TO CARLISLE SPECIFICATIONS FOR REQUIRED NUMBER OF PERIMETER SHEETS, SHEET WIDTH AND MEMBRANE FASTENING DENSITY.
2. HP FASTENERS AND POLYMER SEAM PLATES ARE REQUIRED OVER STEEL DECKS.
3. RUSS "FINGER" MUST EXTEND THE WIDTH OF THE REQUIRED PERIMETER.

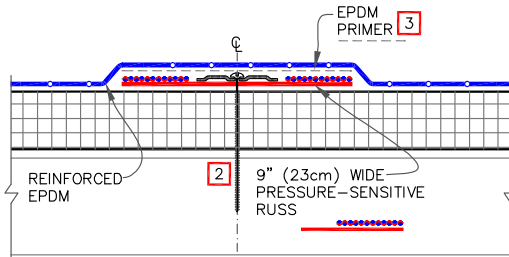

MECHANICALLY FASTENED EPDM SECUREMENT – OPTION 3 (RUSS)

MAXIMUM WARRANTY: 30 YEARS



DETAIL NO.
MF-2.3
MECHANICALLY FASTENED

THERMOSET MEMBRANE

EPDM

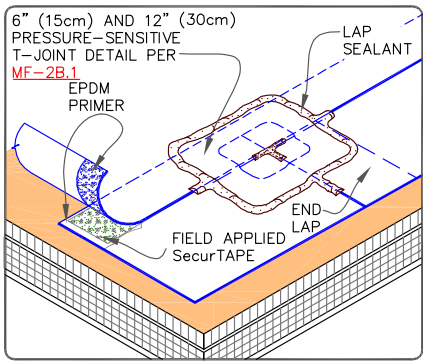
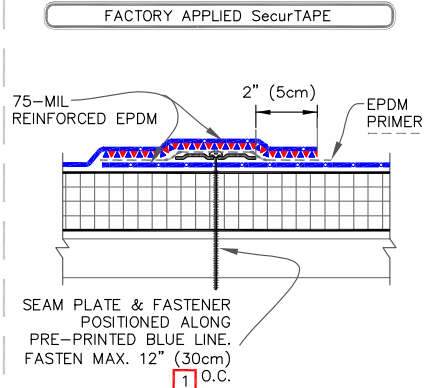
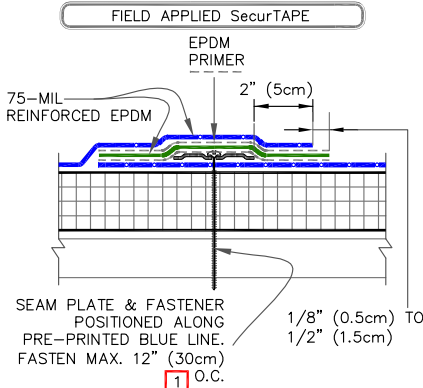

FIELD APPLIED SecurTAPE

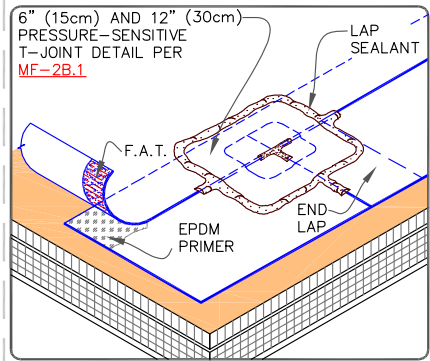

F.A.T. (FACTORY APPLIED SecurTAPE)

NOTES:

1. HP FASTENERS AND POLYMER SEAM PLATES ARE REQUIRED OVER STEEL DECKS.
2. END LAPS SHALL BE SPLICED USING 6" (15cm) WIDE SecurTAPE. REFER TO DETAIL U-2A.1.
3. OVERLAP THE ENDS OF FIELD APPLIED SecurTAPE A MINIMUM OF 1" (2.5cm). APPLY LAP SEALANT AT TAPE OVERLAPS 2" (5cm) IN ALL DIRECTIONS.
4. LAP SEALANT IS REQUIRED ON CUT EDGES OF REINFORCED EPDM MEMBRANE.

	MECHANICALLY FASTENED EPDM MEMBRANE SPLICE (25 / 30 YEAR WARRANTIES)		DETAIL NO.
	MAXIMUM WARRANTY: 30 YEARS		MF-2A.1
		MECHANICALLY FASTENED	

© 2023 Carlisle SynTec a division of Carlisle Construction Materials Incorporated

THERMOSET MEMBRANE

EPDM

6" (15cm) WIDE SecurTAPE SPLICE

6" (15cm) WIDE FACTORY APPLIED TAPE

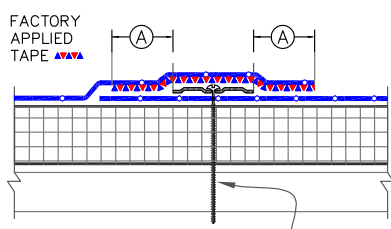
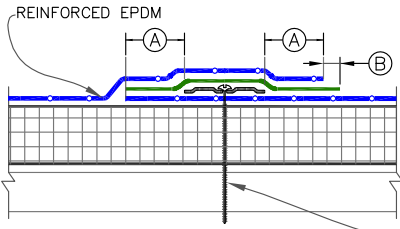

SEAM PLATE & FASTENER POSITIONED OVER PRE-PRINTED BLUE MARKS. FASTEN MAX. 12" (30cm) O.C. **1**

DIMENSIONS	cm	
(A)	2"	5
(B)	1/8"	0.5 TO
	1/2"	1.5

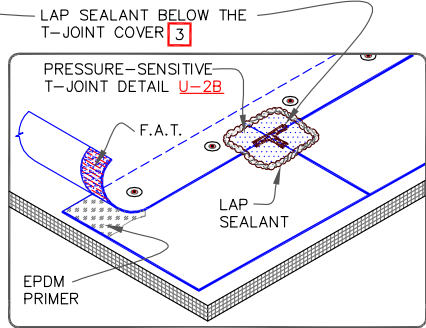
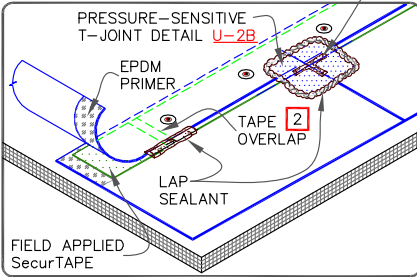

NOTES:

F.A.T. (FACTORY APPLIED SecurTAPE)

1. HP FASTENERS AND POLYMER SEAM PLATES ARE REQUIRED OVER STEEL DECKS.
2. OVERLAP THE ENDS OF FIELD APPLIED SecurTAPE A MINIMUM OF 1" (2.5cm). APPLY LAP SEALANT AT TAPE OVERLAPS 2" (5cm) IN EACH DIRECTION AS SHOWN.
3. APPLY LAP SEALANT ALONG THE LEADING EDGE OF THE MEMBRANE SPLICE UNDER THE 6" (15cm) T-JOINT COVER, COVERING THE EXPOSED SPLICE TAPE 1/2" (1.5cm) IN ALL DIRECTIONS FROM THE SPLICE INTERSECTION.
4. END LAPS SHALL BE SPLICED USING 3" (7.5cm) WIDE SecurTAPE. REFER TO DETAIL [MF-2B](#).
5. LAP SEALANT IS REQUIRED ON CUT EDGES OF REINFORCED EPDM MEMBRANE.



MECHANICALLY FASTENED EPDM MEMBRANE SPLICE

MAXIMUM WARRANTY: 20 YEARS



DETAIL NO.

MF-2A

MECHANICALLY FASTENED

THERMOSET MEMBRANE

EPDM

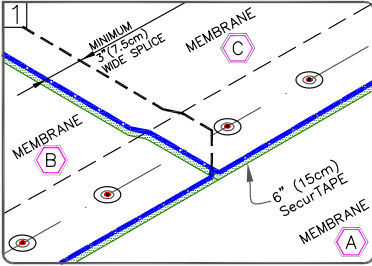

POSITION MEMBRANE TO ALLOW AN APPROXIMATE 7" (17.5cm) OVERLAP ALONG THE LENGTH OF THE MEMBRANE & 4" (10cm) AT END LAPS. THE PRE-MARKED LINE ON THE MEMBRANE EDGE CAN BE USED AS A GUIDE FOR TAPE PLACEMENT.

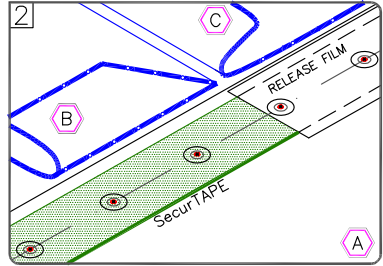

FOLD SHEETS BACK AS SHOWN. APPLY EPDM PRIMER TO THE SPLICE AREA ON BOTH SURFACES AND ALLOW TO FLASH-OFF. APPLY SecurTAPE WITH RELEASE FILM ALIGNED WITH PRE-MARKED LINE.

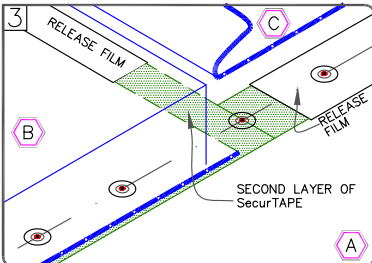

SPLICE SHEET B TO SHEET A AND APPLY SECOND PIECE OF SecurTAPE BETWEEN SHEET B AND C. TRIM RELEASE FILM AS SHOWN.

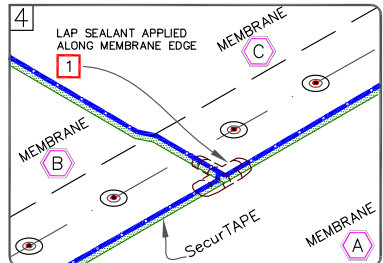

SPLICE SHEET C TO SHEET A AND B. PRESS TOP SHEET ONTO BOTTOM SHEET USING HAND PRESSURE TOWARDS THE OUTER EDGE OF THE SPLICE AND ROLL THE SPLICE AREA WITH A 2" (5cm) WIDE STEEL ROLLER.

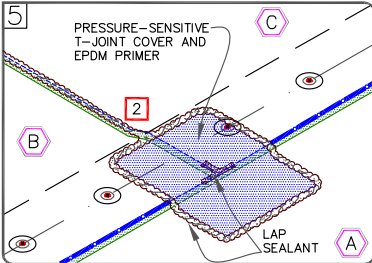

APPLY PRESSURE-SENSITIVE T-JOINT COVER OR 6" (15cm) WIDE SECTION OF PRESSURE-SENSITIVE ELASTOFORM FLASHING CENTERED OVER THE INTERSECTING POINT OF THE LEADING EDGES OF THE FIELD SPLICE INTERSECTION AS SHOWN.

NOTES:

1. APPLY LAP SEALANT ALONG THE EDGE OF THE MEMBRANE SPLICE (BELOW THE 6" (15cm) T-JOINT COVER) COVERING THE EXPOSED SPLICE TAPE 1/2" (1.5cm) IN EACH DIRECTION FROM THE SPLICE INTERSECTION.
2. APPLY LAP SEALANT AT CUT EDGES OF REINFORCED MEMBRANE AND TAPE OVERLAPS. REFER TO [DETAIL MF-2A](#).

	MECHANICALLY FASTENED EPDM MEMBRANE SPLICE INTERSECTION		DETAIL NO.
	MAXIMUM WARRANTY: 20 YEARS		MF-2B
		MECHANICALLY FASTENED	

© 2023 Carlisle SynTec a division of Carlisle Construction Materials Incorporated

THERMOSET MEMBRANE

EPDM

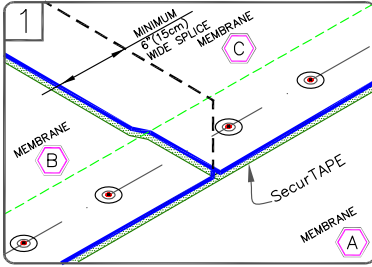

POSITION MEMBRANE TO ALLOW AN APPROXIMATE 7" (17.5cm) OVERLAP. THE PRE-MARKED LINE ON THE MEMBRANE EDGE CAN BE USED AS A GUIDE FOR TAPE PLACEMENT.

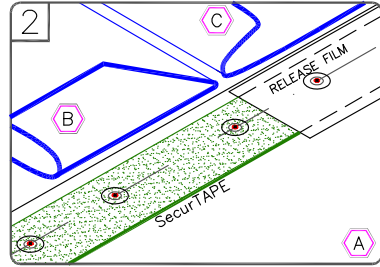

FOLD SHEETS BACK AS SHOWN. APPLY EPDM PRIMER TO THE SPLICE AREA ON BOTH SURFACES AND ALLOW TO FLASH-OFF. APPLY SecurTAPE WITH RELEASE FILM ALIGNED WITH PRE-MARKED LINE.

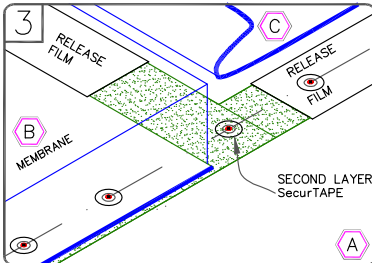

SPLICE SHEET B TO SHEET A AND APPLY SECOND PIECE OF SecurTAPE BETWEEN SHEET B AND C. TRIM RELEASE FILM AS SHOWN.

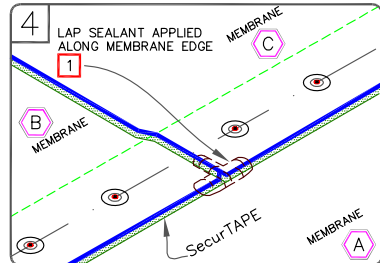

SPLICE SHEET C TO SHEET A AND B, PRESS TOP SHEET ONTO BOTTOM SHEET USING HAND PRESSURE TOWARDS THE OUTER EDGE OF THE SPLICE AND ROLL THE SPLICE AREA WITH A 2" (5cm) WIDE STEEL ROLLER.

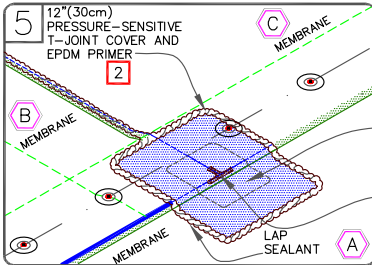

APPLY 6" (15cm) PRESSURE-SENSITIVE T-JOINT COVER AND 12" (30cm) PRESSURE-SENSITIVE T-JOINT COVER OR PRESSURE-SENSITIVE ELASTOFORM CENTERED OVER THE INTERSECTING POINT OF THE LEADING EDGES OF THE FIELD SPLICE INTERSECTION AS SHOWN.

6" (15cm) PRESSURE-SENSITIVE T-JOINT COVER AND EPDM PRIMER

LAP SEALANT BELOW THE 6" (15cm) T-JOINT COVER

NOTES:

1. APPLY LAP SEALANT ALONG THE EDGES OF THE MEMBRANE SPLICE COVERING THE EXPOSED SPLICE TAPE 1/2" (1.5cm) IN EACH DIRECTION FROM THE SPLICE INTERSECTION.
2. APPLY LAP SEALANT AT CUT EDGES OF REINFORCED MEMBRANE AND TAPE OVER LAPS.

	MECHANICALLY FASTENED EPDM MEMBRANE SPLICE INTERSECTION (25 / 30 YEAR WARRANTIES)		DETAIL NO.
	MAXIMUM WARRANTY: 30 YEARS		MF-2B.1
		MECHANICALLY FASTENED	

THERMOSET MEMBRANE

EPDM

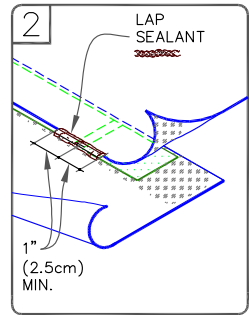
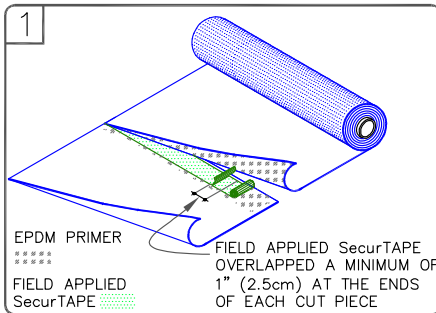
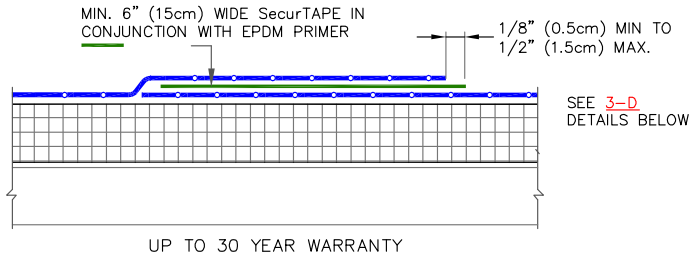
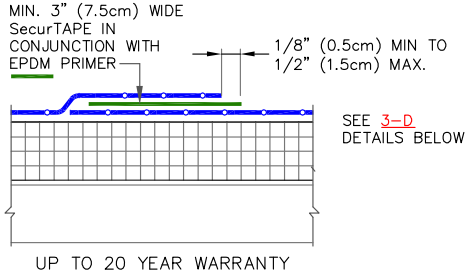

NOTES:

1. APPLY EPDM PRIMER TO THE MEMBRANE SURFACES PRIOR TO INSTALLING PRESSURE-SENSITIVE FLASHING.
2. LAP SEALANT IS REQUIRED ON CUT EDGES OF REINFORCED EPDM MEMBRANE.

	END LAP SPLICE	DETAIL NO. MF-2D
	MAXIMUM WARRANTY: 30 YEARS	

© 2023 Carlisle SynTec a division of Carlisle Construction Materials Incorporated

THERMOSET MEMBRANE

EPDM

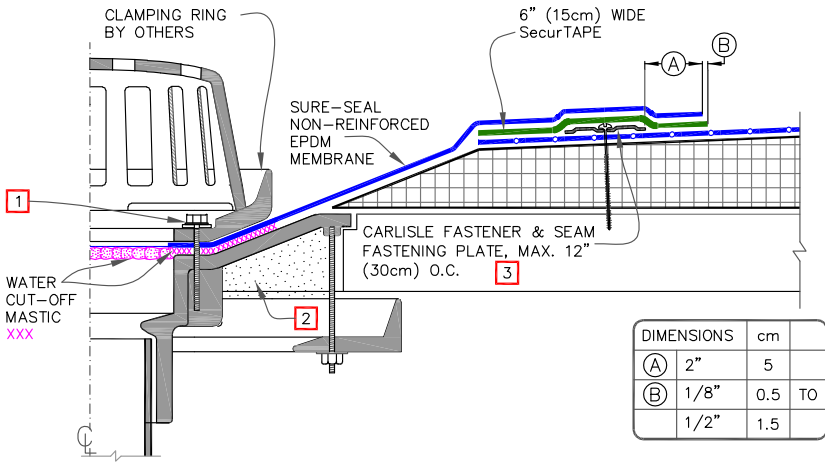

NOTES:

1. ALL BOLTS OR CLAMPS MUST BE IN PLACE TO PROVIDE CONSTANT COMPRESSION ON WATER CUT-OFF MASTIC.
2. REMOVE EXISTING LEAD, FLASHING MATERIAL & ENSURE THE DRAIN RING IS COMPLETELY CLEAN DOWN TO BARE METAL.
3. HP FASTENERS AND POLYMER SEAM PLATES ARE REQUIRED OVER STEEL DECKS.
4. THE HOLE IN THE MEMBRANE SHALL EXCEED THE DIAMETER OF THE DRAIN PIPE, BUT SHALL BE NO LESS THAN 1/2" (1.5cm) FROM THE ATTACHMENT POINTS OF THE DRAIN CLAMPING RING.
5. ROOF DRAIN SIZE AND NUMBER OF DRAINS SHALL BE IN ACCORDANCE WITH THE LOCAL CODES.

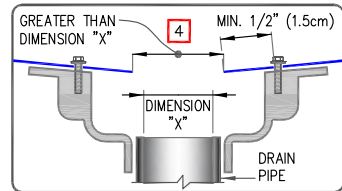

ROOF DRAIN WITH SUMP

MAXIMUM WARRANTY: 30 YEARS



DETAIL NO.
MF-6B

MECHANICALLY FASTENED

© 2023 Carlisle SynTec a division of Carlisle Construction Materials Incorporated

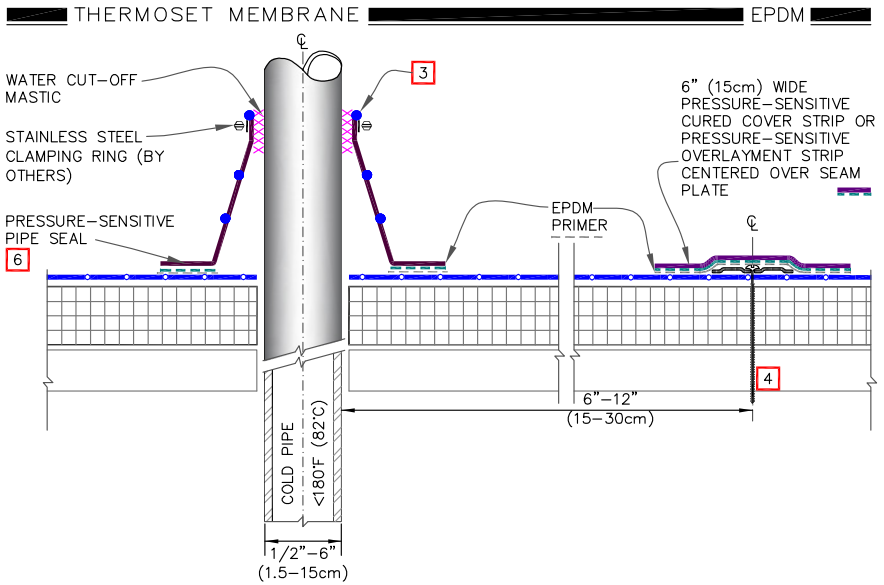

NOTES:

1. REMOVE ALL LEAD AND OTHER FLASHING BEFORE INSTALLING PIPE SEAL.
2. TEMPERATURE OF PIPE MUST NOT EXCEED 180°F (82°C).
3. PRE-MOLDED PIPE SEAL MUST HAVE RIB INTACT AT THE TOP EDGE REGARDLESS OF PIPE DIAMETER.
4. INSTALL A MINIMUM OF 4 SEAM PLATES FOR PIPES WITH A DIAMETER UP TO 6" (15cm). ADDITIONAL SEAM PLATES WILL BE REQUIRED FOR PIPES GREATER THAN 6" (15cm) IN DIAMETER AND SHALL BE SPACED 12" (30cm) ON CENTER MAXIMUM.
5. HP FASTENERS AND POLYMER SEAM PLATES ARE REQUIRED OVER STEEL DECKS.
6. DECK FLANGES OF THE PRESSURE-SENSITIVE PIPE SEAL SHALL NOT BE OVERLAPPED, CUT OR APPLIED OVER ANY ANGLE CHANGE.

	PRESSURE-SENSITIVE PIPE SEAL		DETAIL NO.
	MAXIMUM WARRANTY: 20 YEARS		MF-8A
		MECHANICALLY FASTENED	

© 2023 Carlisle SynTec a division of Carlisle Construction Materials Incorporated

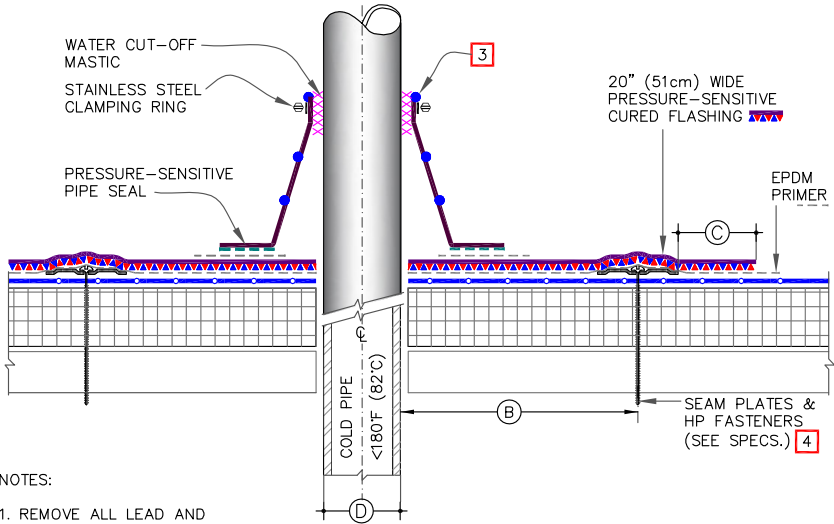

NOTES:

1. REMOVE ALL LEAD AND OTHER FLASHING BEFORE INSTALLING PIPE SEAL.
2. TEMPERATURE OF PIPE MUST NOT EXCEED 180°F (82°C).
3. PRE-MOLDED PIPE SEAL MUST HAVE RIB INTACT AT THE TOP EDGE REGARDLESS OF PIPE DIAMETER.
4. INSTALL A MIN. OF 4 FASTENERS FOR PIPES WITH OUTSIDE DIAMETER <math>< 6''</math> (15cm). SEE DETAIL MF-8B OR MF-8B.1 FOR WIDER PIPES.
5. DECK FLANGES OF THE PRESSURE-SENSITIVE PIPE SEAL SHALL NOT BE OVERLAPPED, CUT OR APPLIED OVER ANY ANGLE CHANGE.

DIMENSIONS	cm	
(A) 1/2"	1.5	
(B) 6"	15	TO
12"	30	
(C) 2"	5	
(D) 1/2"	1.5	TO
6"	15	

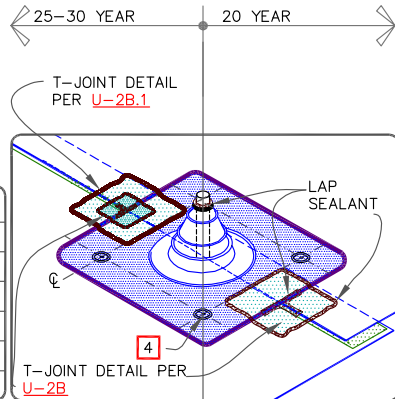

PRESSURE-SENSITIVE PIPE SEAL WITH 20" PRESSURE-SENSITIVE CURED FLASHING

MAXIMUM WARRANTY: 30 YEARS



DETAIL NO. MF-8A.1

MECHANICALLY FASTENED

THERMOSET MEMBRANE EPDM

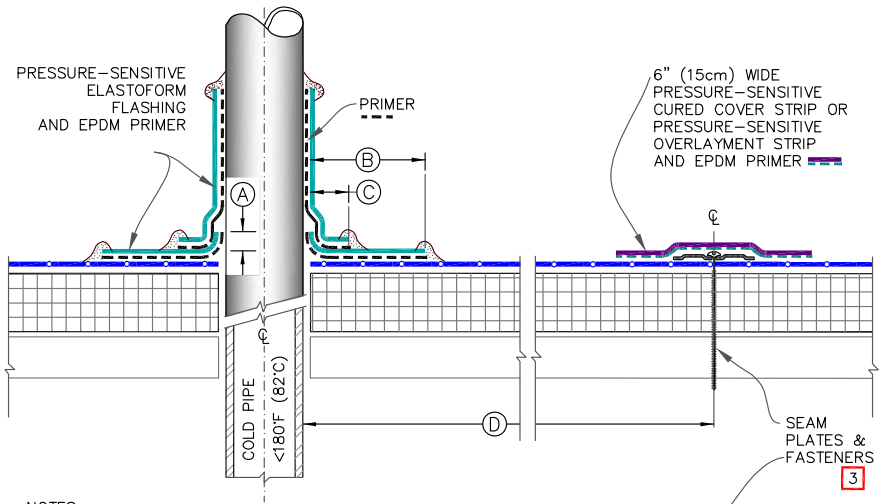

NOTES:

1. REMOVE ALL LEAD AND OTHER FLASHING BEFORE INSTALLING PRESSURE-SENSITIVE ELASTOFORM FLASHING.
2. TEMPERATURE OF PIPE MUST NOT EXCEED 180°F (82°C).
3. HP FASTENERS AND POLYMER SEAM PLATES ARE REQUIRED OVER STEEL DECKS.
4. FOR STRUCTURAL STEEL TUBING GREATER THAN 12" ACROSS USE **U-5** DETAILS.

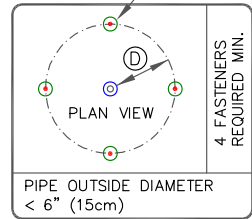

DIMENSIONS	cm	
(A)	1/2"	1.5
(B)	3"	7.5
(C)	1"	2.5
(D)	6"	15 TO
	12"	30
(E)	12"	30 MAX.

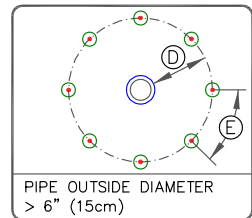

	FIELD FABRICATED PIPE WRAP		DETAIL NO.
	MAXIMUM WARRANTY: 20 YEARS		MECHANICALLY FASTENED

© 2023 Carlisle SynTec a division of Carlisle Construction Materials Incorporated

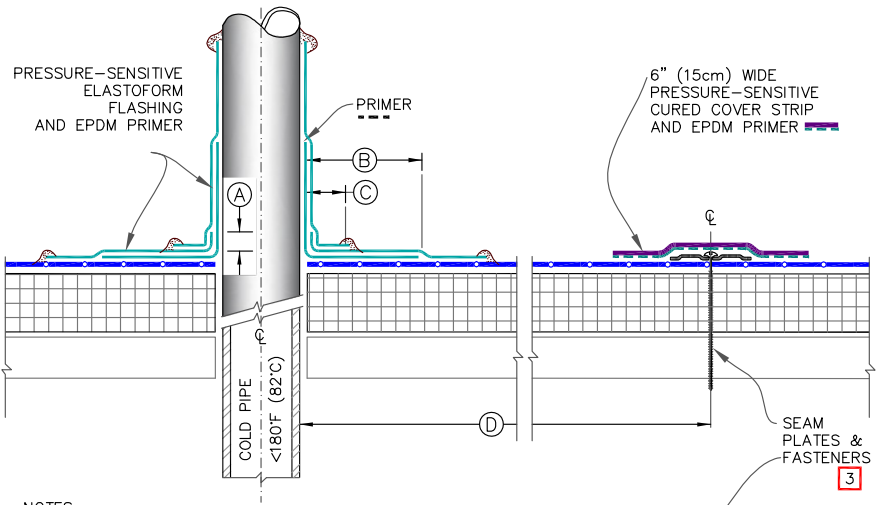

NOTES:

1. REMOVE ALL LEAD AND OTHER FLASHING BEFORE INSTALLING PRESSURE-SENSITIVE ELASTOFORM FLASHING.
2. TEMPERATURE OF PIPE MUST NOT EXCEED 180F (82°C).
3. HP FASTENERS AND POLYMER SEAM PLATES ARE REQUIRED OVER STEEL DECKS.
4. FOR STRUCTURAL STEEL TUBING GREATER THAN 12" ACROSS USE [U-5](#) DETAILS.

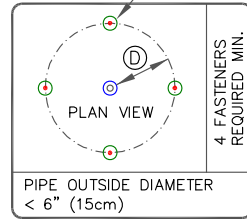

DIMENSIONS	cm	
(A)	1/2"	1.5
(B)	3"	7.5
(C)	1"	2.5
(D)	6"	15 TO
	12"	30
(E)	12"	30 MAX.

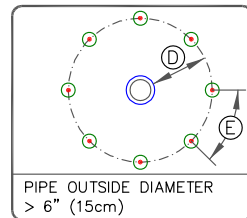

	FIELD FABRICATED PIPE WRAP (25/30 YEAR WARRANTIES)		DETAIL NO.
	MAXIMUM WARRANTY: 30 YEARS		MF-8B.1
		MECHANICALLY FASTENED	

■■■■ THERMOSET MEMBRANE ■■■■ EPDM ■■■■

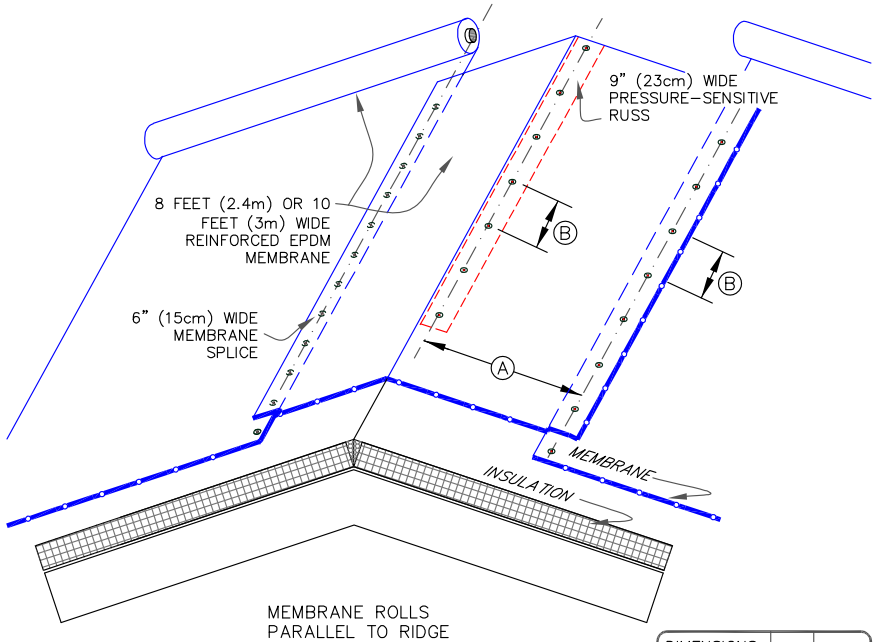

DIMENSIONS	cm	
(A)	3'-6"	110 MIN.
	4'-6"	140 MAX.
(B)	12" O.C.	30 MAX.

NOTES:

1. RIDGE MEMBRANE ATTACHMENT IS ONLY REQUIRED WHEN ROOF SLOPE EXCEEDS 3" TO THE HORIZONTAL FOOT (7.5cm/30cm).
2. REINFORCED EPDM MEMBRANE SHALL BE INSTALLED PARALLEL WITH RIDGE LINE (WITH MEMBRANE CENTERED OVER THE RIDGE LINE) AS SHOWN.
3. FOR PROPER MEMBRANE ATTACHMENT AND SPlicing, [REFER TO APPLICABLE MF-2 DETAIL.](#)
4. REFER TO CARLISLE SPECIFICATIONS FOR REQUIRED NUMBER OF PERIMETER SHEETS, SHEET WIDTH AND MEMBRANE FASTENING DENSITY.
5. HP FASTENERS AND POLYMER SEAM PLATES ARE REQUIRED OVER STEEL DECKS.
6. AS AN OPTION, 9" (23cm) WIDE PRESSURE-SENSITIVE RUSS MAY BE USED BENEATH EPDM FIELD SHEETS FOR PERIMETER SECUREMENT.

	RIDGE MEMBRANE ATTACHMENT		DETAIL NO.
	MAXIMUM WARRANTY: 30 YEARS		MF-22
		MECHANICALLY FASTENED	

© 2023 Carlisle SynTec a division of Carlisle Construction Materials Incorporated

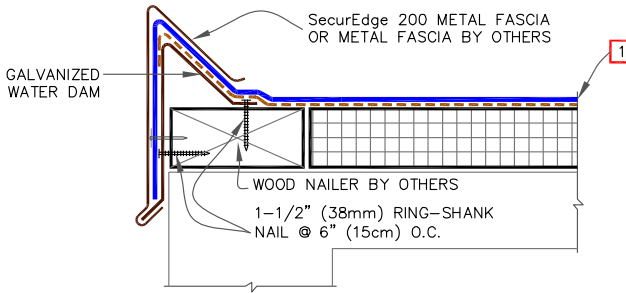

NOTE:

1. MAXIMUM MEMBRANE THICKNESS GOING OVER THE WATER DAM IS 60-MIL. FOR THICKER MEMBRANES, RUN FIELD SHEET UNDER THE WATER DAM AND STRIP-IN WITH MAXIMUM 60-MIL MEMBRANE.
2. USE **MF-1A** FOR MECHANICALLY FASTENED SYSTEMS AND **B-1A** FOR BALLASTED SYSTEMS.

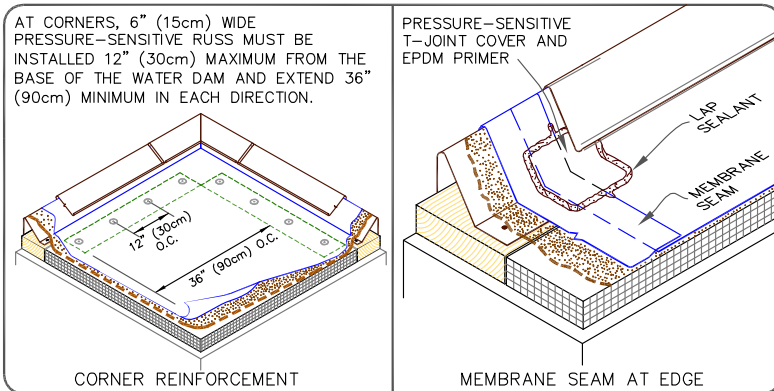

CARLISLE SecurEDGE 200

MAXIMUM WARRANTY: 20 YEARS



DETAIL NO.

U-1A

THERMOSET UNIVERSAL

THERMOSET MEMBRANE

EPDM

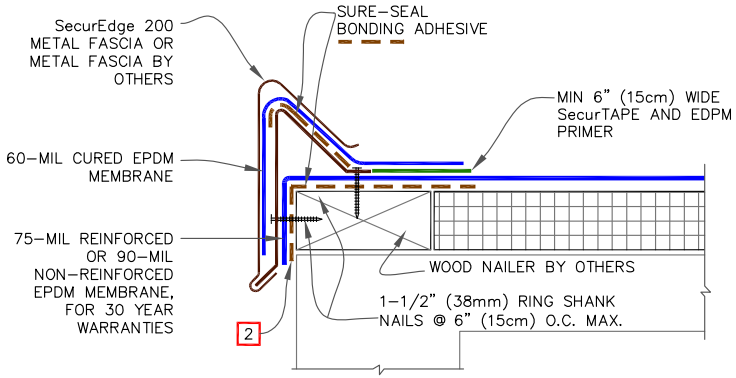

NOTES:

1. FIELD SPLICES AT THE ANGLE CHANGE SHALL BE OVERLAID WITH EPDM PRIMER AND TWO LAYERS OF PRESSURE-SENSITIVE ELASTOFORM FLASHING. PER DETAIL [U-2C](#).
2. WHEN AN AIR/VAPOR BARRIER IS NOT SPECIFIED, THE ROOF MEMBRANE SHALL BE ADHERED OVER PERIMETER WOOD NAILER ALONG EDGES TO PREVENT AIR INFILTRATION ALONG EDGING, REGARDLESS OF ASSEMBLY TYPE (BALLASTED, ADHERED AND MECHANICALLY FASTENED).

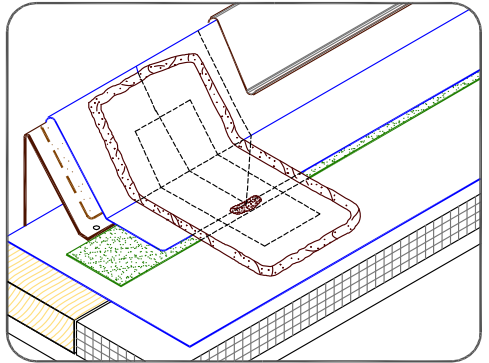

	CARLISLE SecurEdge 200 (25/30 YEAR WARRANTIES)		DETAIL NO.
	MAXIMUM WARRANTY: 30 YEARS		U-1A.1
		THERMOSET UNIVERSAL	

© 2023 Carlisle SynTec a division of Carlisle Construction Materials Incorporated

THERMOSET MEMBRANE

EPDM

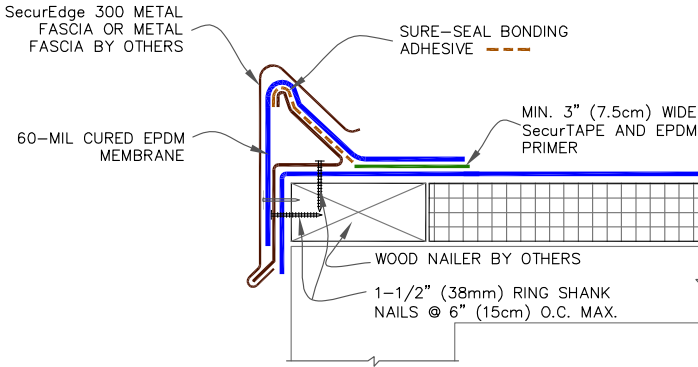

NOTE:

1. 6" (15cm) WIDE PRESSURE-SENSITIVE ELASTOFORM FLASHING, IN CONJUNCTION WITH EPDM PRIMER, MUST BE CENTERED OVER FIELD SPLICES AT THE ANGLE CHANGE.

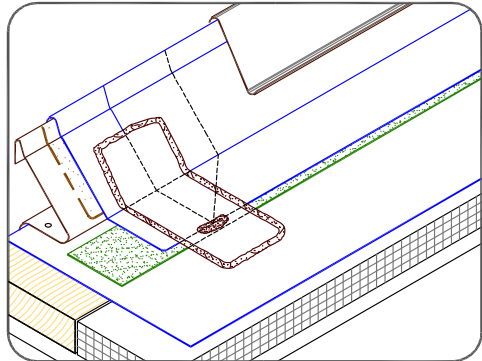

CARLISLE SecurEdge 300

MAXIMUM WARRANTY: 20 YEARS



DETAIL NO.

U-1B

THERMOSET UNIVERSAL

© 2023 Carlisle SynTec a division of Carlisle Construction Materials Incorporated

THERMOSET MEMBRANE

EPDM

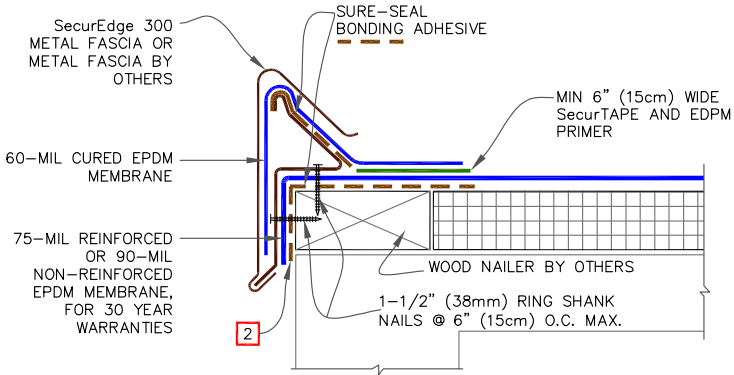

NOTES:

1. FIELD SPLICES AT THE ANGLE CHANGE SHALL BE OVERLAID WITH EPDM PRIMER AND 2 LAYERS OF PRESSURE-SENSITIVE ELASTOFORM FLASHING PER DETAIL [U-2C](#).
2. WHEN AIR/VAPOR BARRIER IS NOT SPECIFIED, THE ROOF MEMBRANE SHALL BE ADHERED OVER PERIMETER WOOD NAILER ALONG EDGES TO PREVENT AIR INFILTRATION ALONG EDGING, REGARDLESS OF ASSEMBLY TYPE (BALLASTED, ADHERED AND MECHANICALLY FASTENED).

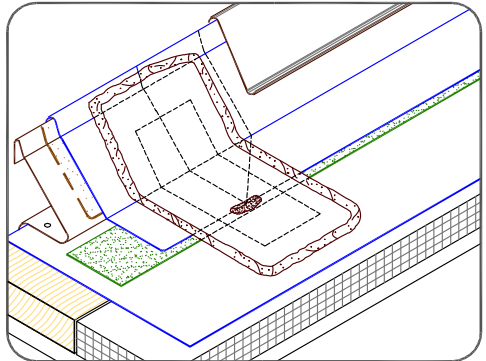

	CARLISLE SecurEdge 300 (25/30 YEAR WARRANTIES)		DETAIL NO.
	MAXIMUM WARRANTY: 30 YEARS		U-1B.1
		THERMOSET UNIVERSAL	

© 2023 Carlisle SynTec a division of Carlisle Construction Materials Incorporated

THERMOSET MEMBRANE EPDM

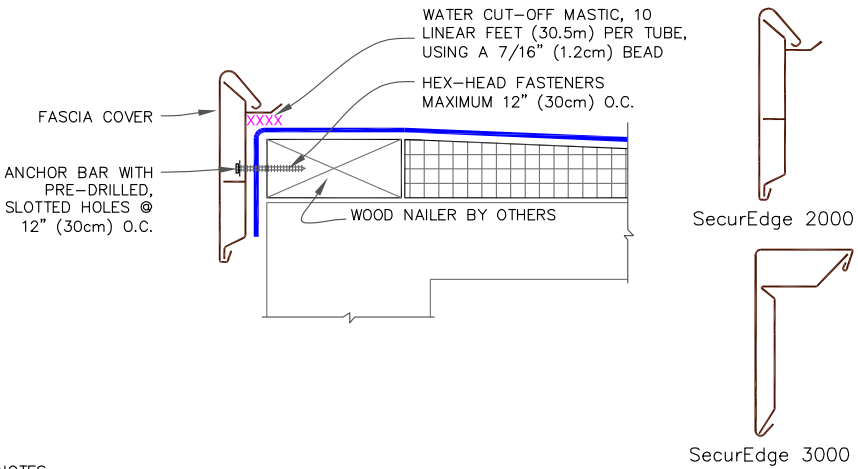

NOTES:

1. IF INCIDENTAL/TEMPORARY PONDED WATER IS EXPECTED, THE SecurEdge MUST BE ELEVATED AND SCUPPERS PROVIDED FOR DRAINAGE.
2. ENSURE ROOF SLOPES AWAY FROM SecurEDGE.

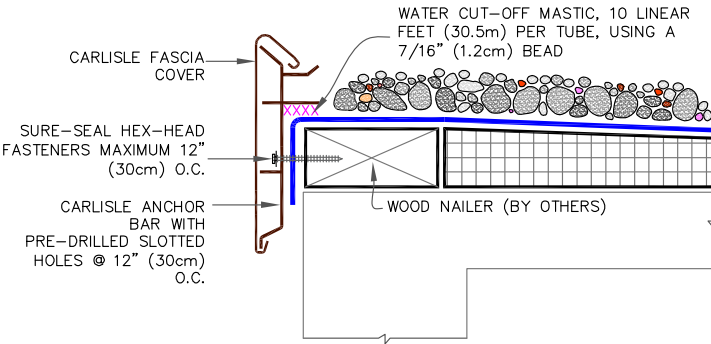

	CARLISLE SecurEdge 2000 & 3000		DETAIL NO.
	MAXIMUM WARRANTY: 30 YEARS		U-1C
		THERMOSET UNIVERSAL	

© 2023 Carlisle SynTec a division of Carlisle Construction Materials Incorporated

THERMOSET MEMBRANE

EPDM

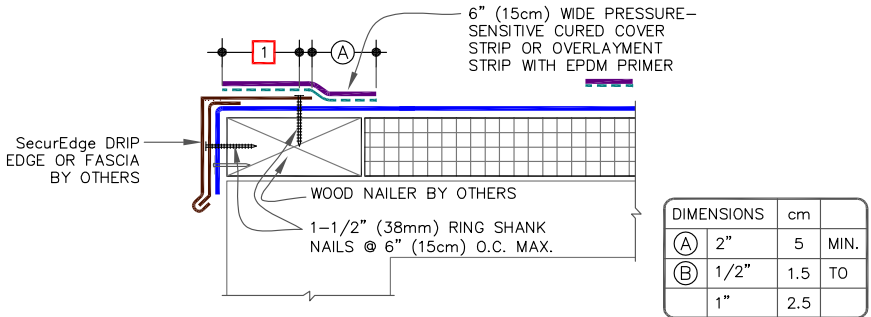

DIMENSIONS		cm	
(A)	2"	5	MIN.
(B)	1/2"	1.5	TO
	1"	2.5	

NOTES:

1. DECK FLANGE MUST BE TOTALLY COVERED WITH MINIMUM 2" (5cm) COVERAGE PAST NAIL HEADS. TO REMOVE FINISHING OILS, SCRUB METAL FLANGE WITH WEATHERED MEMBRANE CLEANER; ALLOW TO DRY PRIOR TO APPLYING PRIMER.
2. LAP SEALANT MUST BE APPLIED AT FLASHING OVERLAPS AND INTERSECTIONS WITH JOINTS IN METAL EDGING.
3. T-JOINT COVER NOT NEEDED WHEN USING PS OVERLAYMENT STRIP ON MEMBRANE LESS THAN 90-MIL.
4. WHEN USING 90-MIL MEMBRANE INSTALL A 12" (30cm) T-JOINT COVER OVER THE 6" (15cm) T-JOINT COVER PER [U-2B.1](#)
5. DETAIL NOT FOR USE WITH DESIGN "B" (BALLASTED STONE ASSEMBLY).

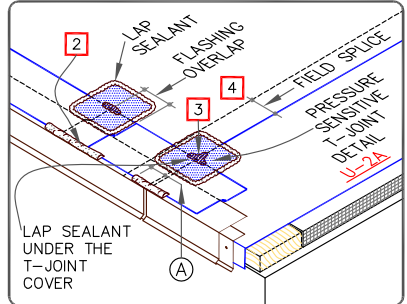
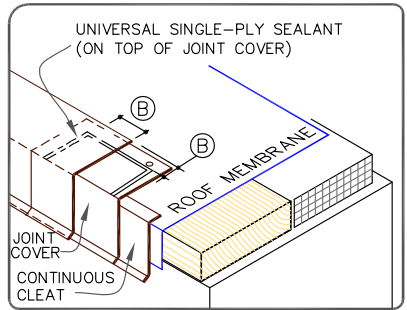

	SecurEdge DRIP EDGE FASCIA		DETAIL NO.
	MAXIMUM WARRANTY: 20 YEARS		U-1D
		THERMOSET UNIVERSAL	

© 2023 Carlisle SynTec a division of Carlisle Construction Materials Incorporated

THERMOSET MEMBRANE

EPDM

OPTION 1

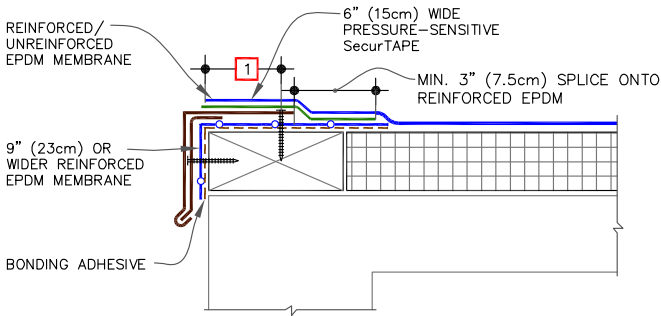

OPTION 2

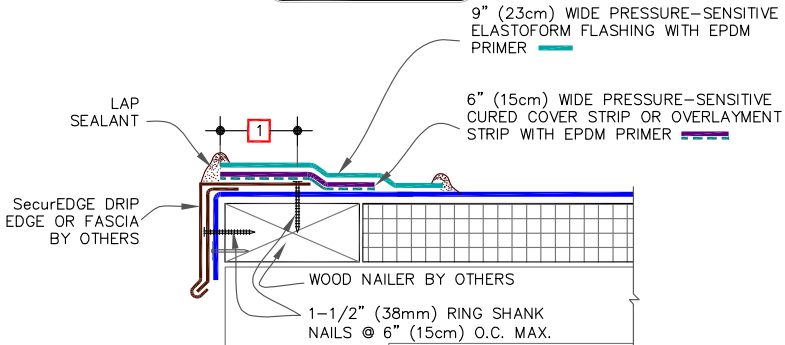

NOTES:

1. DECK FLANGE MUST BE TOTALLY COVERED WITH MINIMUM 2" (5cm) COVERAGE PAST NAIL HEADS. TO REMOVE FINISHING OILS, SCRUB METAL FLANGE WITH WEATHERED MEMBRANE CLEANER; ALLOW TO DRY PRIOR TO APPLYING PRIMER.
2. LAP SEALANT MUST BE APPLIED AT FLASHING OVERLAPS AND INTERSECTIONS WITH JOINTS IN METAL EDGING.
3. ALL SPLICE INTERSECTIONS MUST BE OVERLAID WITH PRESSURE-SENSITIVE T-JOINT COVERS AND SEALED WITH CONTINUOUS LAP SEALANT. PRIOR TO DOING SO, APPLY LAP SEALANT ALONG THE LEADING EDGE OF THE MEMBRANE SPLICES (UNDER THE 6"X 6" (15cm X 15cm) T-JOINT COVER) COVERING THE EXPOSED SPLICE TAPE 1/2" (1.5cm) IN ALL DIRECTIONS FROM THE SPLICE INTERSECTION.
4. DETAIL NOT FOR USE WITH DESIGN "B" (BALLASTED STONE ASSEMBLY).

	SecurEdge DRIP EDGE FASCIA (25/30 YEAR WARRANTIES)		DETAIL NO.
	MAXIMUM WARRANTY: 30 YEARS		U-1D.1
		THERMOSET UNIVERSAL	

© 2023 Carlisle SynTec a division of Carlisle Construction Materials Incorporated

THERMOSET MEMBRANE

EPDM

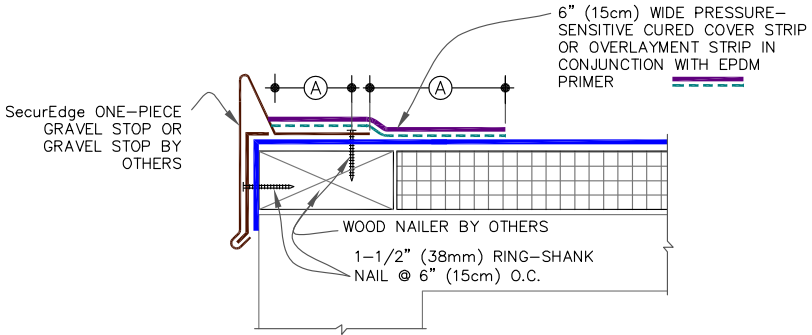

NOTES:

1. TO REMOVE FINISHING OILS, SCRUB METAL FLANGE WITH WEATHERED MEMBRANE CLEANER; ALLOW TO DRY PRIOR TO APPLYING PRIMER.
2. LAP SEALANT MUST BE APPLIED AT FLASHING OVERLAPS AND INTERSECTIONS WITH JOINTS IN METAL EDGING.
3. T-JOINT COVER AT SPLICE INTERSECTION NOT NEEDED WHEN USING PS OVERLAYMENT STRIP ON MEMBRANE LESS THAN 90-MIL.
4. WHEN USING 90-MIL MEMBRANE INSTALL A 12" (30cm) T-JOINT COVER OVER THE 6" (15cm) T-JOINT COVER PER [U-2B.1](#)

DIMENSION	cm	
(A)	2"	5 MIN.

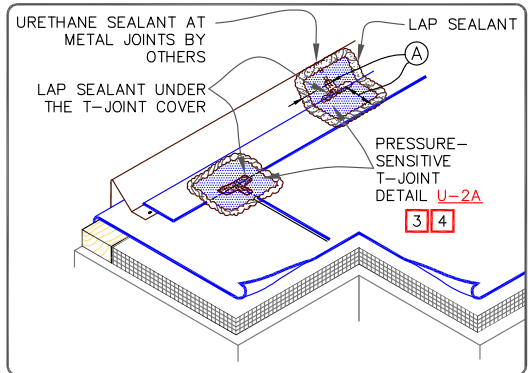

	SecurEdge ONE-PIECE GRAVEL STOP		DETAIL NO.
	MAXIMUM WARRANTY: 20 YEARS		U-1E

© 2023 Carlisle SynTec a division of Carlisle Construction Materials Incorporated

THERMOSET MEMBRANE

EPDM

NON-BALLASTED SYSTEMS

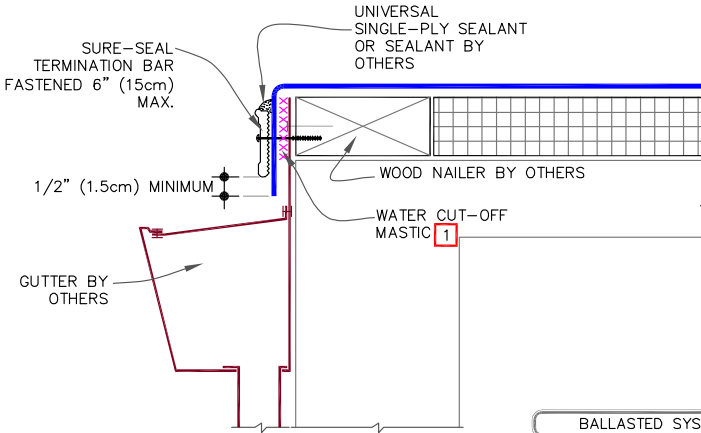

BALLASTED SYSTEMS

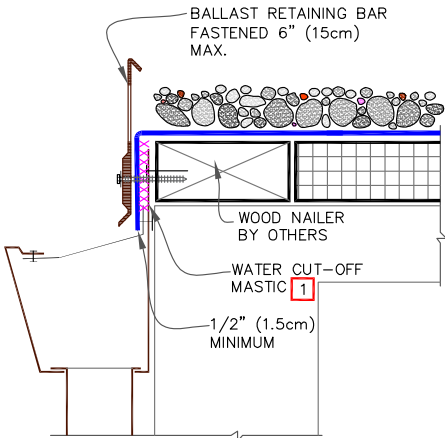

NOTES:

1. FASTENING OF METAL TERMINATION OR BALLAST RETAINING BAR MUST PROVIDE CONSTANT COMPRESSION ON WATER CUT-OFF MASTIC.
2. BALLAST RETAINING BAR MUST EXTEND ABOVE GRAVEL SURFACE SUFFICIENTLY TO RETAIN GRAVEL AND PREVENT GRAVEL MIGRATION.
3. SLOTS IN BALLAST RETAINING BAR MUST BE FLUSH OR SLIGHTLY BELOW MEMBRANE LEVEL.

	METAL BAR EDGE TERMINATION		DETAIL NO.
	MAXIMUM WARRANTY: 30 YEARS		U-1F
		THERMOSET UNIVERSAL	

© 2023 Carlisle SynTec a division of Carlisle Construction Materials Incorporated

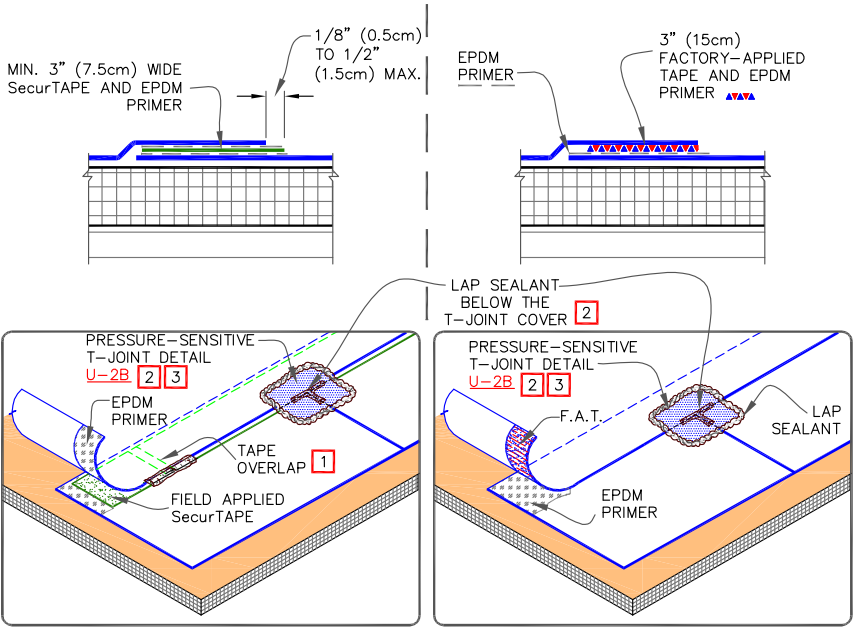

THERMOSET MEMBRANE

EPDM



NOTES:

- OVERLAP THE ENDS OF THE FIELD APPLIED SecurTAPE A MINIMUM OF 1" (2.5cm). APPLY LAP SEALANT AT TAPE OVERLAPS 2" (5cm) IN EACH DIRECTION AS SHOWN.
- APPLY LAP SEALANT ALONG THE EXPOSED EDGE OF THE MEMBRANE SPLICE COVERING THE EXPOSED SPLICE TAPE 1/2" (1.5cm) IN EACH DIRECTION FROM THE SPLICE INTERSECTION AND OVERLAY WITH A 6" (15cm) T-JOINT COVER.
- WHEN USING 90-MIL MEMBRANE, INSTALL A 12" (30cm) T-JOINT COVER CENTERED OVER THE FIRST T-JOINT COVER PER DETAIL [U-2B.1](#).
- LAP SEALANT IS REQUIRED ON CUT EDGES OF REINFORCED EPDM MEMBRANE.
- REFER TO DETAIL [MF-2A](#) FOR MECHANICALLY FASTENED SPLICES.

	EPDM MEMBRANE SPLICE		DETAIL NO.
	MAXIMUM WARRANTY: 20 YEARS		U-2A
		THERMOSET UNIVERSAL	

© 2023 Carlisle SynTec a division of Carlisle Construction Materials Incorporated

THERMOSET MEMBRANE

EPDM

OPTION 1

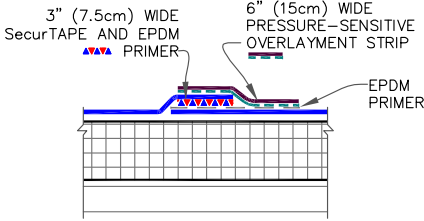

OPTION 2

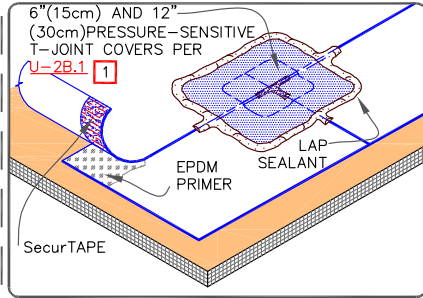
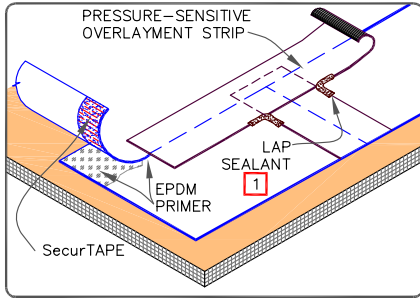
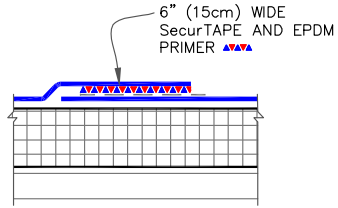

F.A.T. (FACTORY APPLIED SecurTAPE)

NOTES:

1. APPLY LAP SEALANT AT ALL INTERSECTIONS BETWEEN PRESSURE-SENSITIVE OVERLAYMENT STRIP.
2. REFER TO DETAIL [MF-2A.1](#) FOR MECHANICALLY-FASTENED SPLICES.

NOTE:

1. APPLY LAP SEALANT ALONG THE EXPOSED EDGE OF THE MEMBRANE SPLICE COVERING THE EXPOSED SPLICE TAPE 1/2" (1.5cm) IN EACH DIRECTION FROM THE SPLICE INTERSECTION AND OVERLAY WITH A 6" (15cm) T-JOINT COVER. INSTALL A 12" (30cm) T-JOINT COVER CENTERED OVER THE FIRST T-JOINT COVER PER DETAIL [U-2B.1](#).

	EPDM MEMBRANE SPLICE (25/30 YEAR WARRANTIES)		DETAIL NO. U-2A.1
	MAXIMUM WARRANTY: 30 YEARS		THERMOSET UNIVERSAL

© 2023 Carlisle SynTec a division of Carlisle Construction Materials Incorporated

THERMOSET MEMBRANE

EPDM

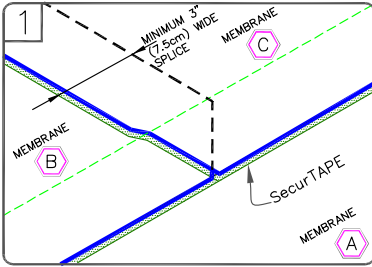

POSITION MEMBRANE TO ALLOW AN APPROXIMATE 4" (10cm) OVERLAP. MARK THE BOTTOM SHEET WITH AN INDELIBLE MARKER 1/2" (1.5cm) FROM THE EDGE OF THE TOP SHEET AS SHOWN. THE PRE-MARKED LINE ON THE MEMBRANE EDGE CAN ALSO BE USED AS A GUIDE.

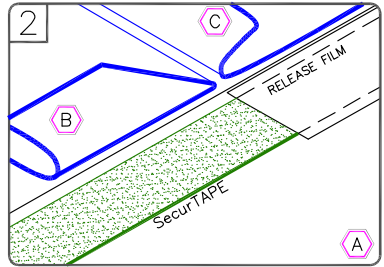

FOLD SHEETS BACK AS SHOWN. APPLY EPDM PRIMER TO THE SPLICE AREA ON BOTH SURFACES AND ALLOW TO FLASH-OFF. APPLY SecurTAPE WITH RELEASE FILM ALIGNED WITH MARKED LINE.

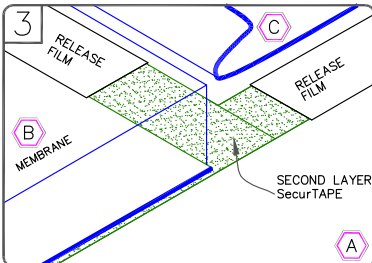

SPLICE SHEET B TO SHEET A AND APPLY SECOND PIECE OF SecurTAPE BETWEEN SHEET B AND C. TRIM RELEASE FILM AS SHOWN.

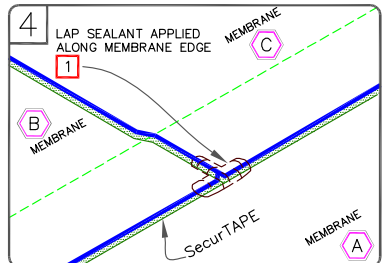

SPLICE SHEET C TO SHEET A AND B, PRESS TOP SHEET ONTO BOTTOM SHEET USING HAND PRESSURE TOWARDS THE OUTER EDGE OF THE SPLICE AND ROLL THE SPLICE AREA WITH A 2" (5cm) WIDE STEEL ROLLER.

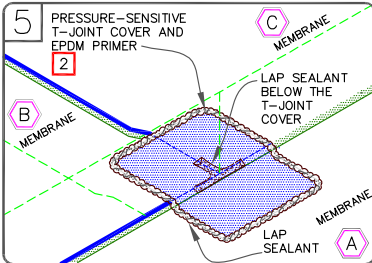

APPLY PRESSURE-SENSITIVE T-JOINT COVER OR 6" (15cm) WIDE SECTION OF PRESSURE-SENSITIVE ELASTOFORM FLASHING CENTERED OVER THE INTERSECTING POINT OF THE LEADING EDGES OF THE FIELD SPLICE INTERSECTION AS SHOWN.

NOTES:

1. APPLY LAP SEALANT ALONG THE EDGE OF THE MEMBRANE SPLICE BELOW THE 6" (15cm) T-JOINT COVER, COVERING THE EXPOSED SPLICE TAPE 1/2" (1.5cm) IN EACH DIRECTION FROM THE SPLICE INTERSECTION.
2. APPLY LAP SEALANT AT CUT EDGES OF REINFORCED MEMBRANE AND TAPE OVERLAPS. REFER TO [DETAIL U-2A](#).
3. REFER TO [DETAIL U-2B.1](#) WHEN USING 90-MIL MEMBRANE.

	EPDM MEMBRANE SPLICE INTERSECTION		DETAIL NO.
	MAXIMUM WARRANTY: 20 YEARS		U-2B
		THERMOSET UNIVERSAL	

© 2023 Carlisle SynTec a division of Carlisle Construction Materials Incorporated

THERMOSET MEMBRANE

EPDM

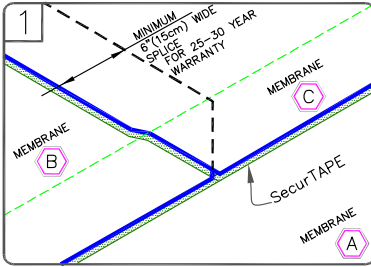

POSITION MEMBRANE TO ALLOW AN APPROXIMATE 7" (17.5cm) OVERLAP. MARK THE BOTTOM SHEET WITH AN INDELIBLE MARKER 1/2" (1.5cm) FROM THE EDGE OF THE TOP SHEET AS SHOWN. THE PRE-MARKED LINE ON THE MEMBRANE EDGE CAN ALSO BE USED AS A GUIDE.

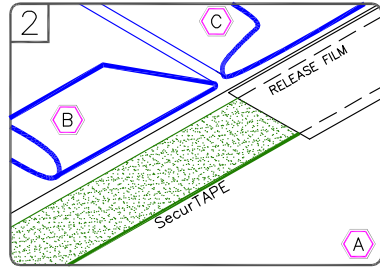

FOLD SHEETS BACK AS SHOWN. APPLY EPDM PRIMER TO THE SPLICE AREA ON BOTH SURFACES AND ALLOW TO FLASH-OFF. APPLY SecurTAPE WITH RELEASE FILM ALIGNED WITH MARKED LINE.

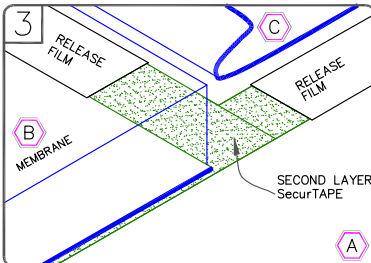

SPLICE SHEET B TO SHEET A AND APPLY SECOND PIECE OF SecurTAPE BETWEEN SHEET B AND C. TRIM RELEASE FILM AS SHOWN.

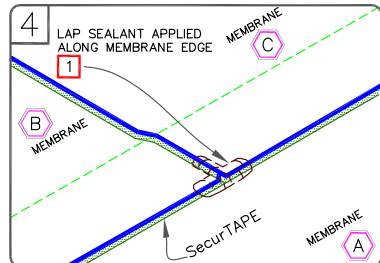

SPLICE SHEET C TO SHEET A AND B, PRESS TOP SHEET ONTO BOTTOM SHEET USING HAND PRESSURE TOWARDS THE OUTER EDGE OF THE SPLICE AND ROLL THE SPLICE AREA WITH A 2" (5cm) WIDE STEEL ROLLER.

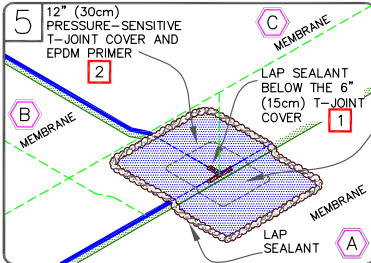

APPLY 6" (15cm) PRESSURE-SENSITIVE T-JOINT COVER AND 12" (30cm) PRESSURE-SENSITIVE T-JOINT COVER OR PRESSURE-SENSITIVE ELASTOFORM CENTERED OVER THE INTERSECTING POINT OF THE LEADING EDGES OF THE FIELD SPLICE INTERSECTION AS SHOWN.

6" (15cm) PRESSURE-SENSITIVE T-JOINT COVER AND EPDM PRIMER

NOTES:

1. APPLY LAP SEALANT ALONG THE EDGES OF THE MEMBRANE SPLICE COVERING THE EXPOSED SPLICE TAPE 1/2" (1.5cm) IN EACH DIRECTION FROM THE SPLICE INTERSECTION.
2. APPLY LAP SEALANT AT CUT EDGES OF REINFORCED MEMBRANE AND TAPE OVER LAPS.

	EPDM MEMBRANE SPLICE INTERSECTION (25 / 30 YEAR WARRANTIES OR 90mil MEMBRANE)		DETAIL NO. U-2B.1
	MAXIMUM WARRANTY: 30 YEARS		THERMOSET UNIVERSAL

THERMOSET MEMBRANE

EPDM

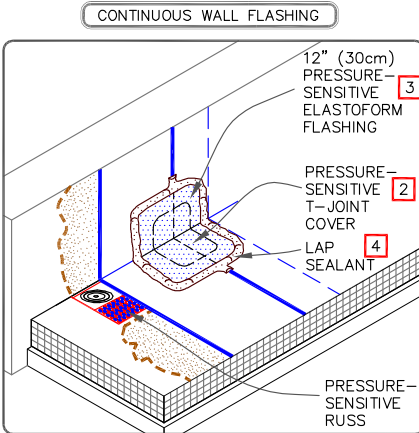
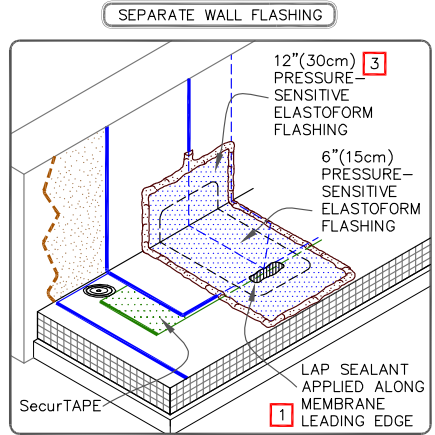
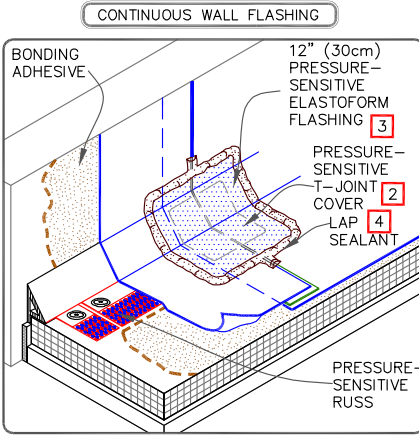

NOTES:

1. APPLY LAP SEALANT ALONG THE LEADING EDGE OF THE MEMBRANE SPLICE (UNDER THE PRESSURE-SENSITIVE ELASTOFORM FLASHING) COVERING THE EXPOSED SPLICE TAPE APPROXIMATELY 1/2" (1.5cm) BEYOND THE SPLICE EDGE.
2. PRESSURE-SENSITIVE T-JOINT COVER OR 6" (15cm) WIDE PRESSURE-SENSITIVE FLASHING, IN CONJUNCTION WITH EPDM PRIMER, MUST BE CENTERED OVER FIELD SPLICES AT THE ANGLE CHANGE.
3. PROJECTS WITH 25 AND 30-YEAR WARRANTIES OR WHEN USING 90-MIL MEMBRANE REQUIRE FIELD SPLICES TO BE OVERLAID WITH TWO LAYERS OF PRESSURE-SENSITIVE ELASTOFORM FLASHING. THE BOTTOM LAYER SHALL BE 6" (15cm) WIDE COVERED WITH A 12" (30cm) WIDE TOP LAYER. BOTH LAYERS SHALL BE CENTERED.
4. SEAL EXPOSED LAYER WITH LAP SEALANT.

	EPDM MEMBRANE SPLICES AT ANGLE CHANGE		DETAIL NO.
	MAXIMUM WARRANTY: 30 YEARS		U-2C
		THERMOSET UNIVERSAL	

© 2023 Carlisle SynTec a division of Carlisle Construction Materials Incorporated

THERMOSET MEMBRANE

EPDM

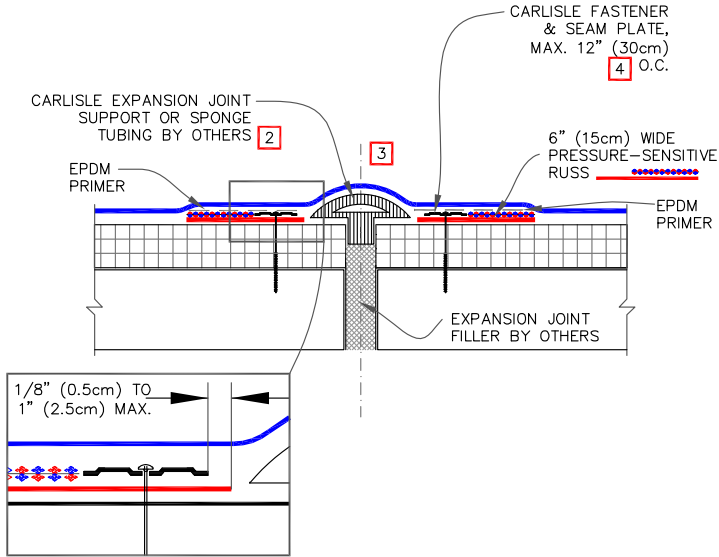

NOTES:

- FOR EXPANSION JOINT INTERSECTIONS AND INTERSECTIONS BETWEEN EXPANSION JOINTS TO WALL OR EDGING, USE TWO LAYERS OF PRESSURE-SENSITIVE ELASTOFORM FLASHING WITH SECOND LAYER 3" (7.5cm) LARGER THAN PREVIOUS LAYER IN ALL DIRECTIONS.
- ROOF MEMBRANE SHALL BE LOOSE-LAID OVER THE EXPANSION JOINT SUPPORT OR SPONGE TUBING.
- WIDTH OF JOINT SHALL BE A MINIMUM OF 3/4" (2cm) AND MAXIMUM 3" (7.5cm) WHEN USING CARLISLE EXPANSION JOINTS.
- HP FASTENERS AND POLYMER SEAM PLATES ARE REQUIRED ON MECHANICALLY FASTENED SYSTEMS OVER STEEL DECKS.

	DECK-TO-DECK EXPANSION JOINT		DETAIL NO.
	MAXIMUM WARRANTY: 30 YEARS		U-3A
		THERMOSET UNIVERSAL	

© 2023 Carlisle SynTec a division of Carlisle Construction Materials Incorporated

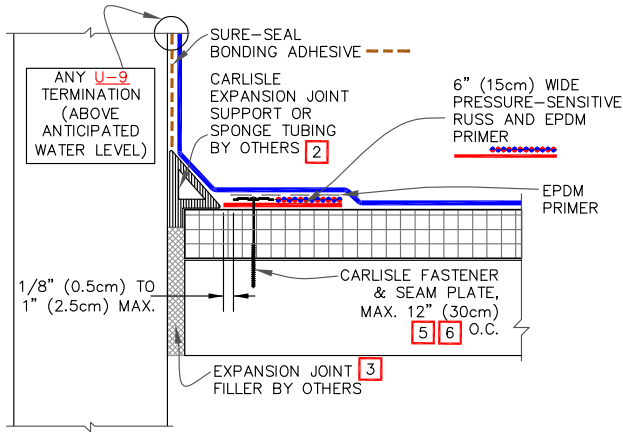

THERMOSET MEMBRANE

EPDM



NOTES:

1. ALL OUTSIDE AND INSIDE CORNERS REQUIRE TWO COMPLETE CORNER APPLICATIONS OF PRESSURE-SENSITIVE ELASTOFORM FLASHING AS PER [DETAILS U-15D.1 OR U-15G.1](#).
2. ROOF MEMBRANE SHALL BE LOOSE-LAID OVER THE EXPANSION JOINT SUPPORT OR SPONGE TUBING.
3. WIDTH OF JOINT SHALL BE A MINIMUM OF 3/4" (2cm) AND MAXIMUM 2" (5cm) WHEN CARLISLE EXPANSION JOINT SUPPORT IS USED.
4. USE [DETAIL U-2C](#) FOR EPDM MEMBRANE SPLICES AT ANGLE CHANGES.
5. HP FASTENERS AND POLYMER SEAM PLATES ARE REQUIRED ON MECHANICALLY FASTENED SYSTEMS OVER STEEL DECKS.
6. MAXIMUM 6" (15cm) FASTENER SPACING FOR WARRANTY WIND SPEEDS GREATER THAN 90 MPH OR WARRANTIES EXCEEDING 20 YEARS.

	DECK-TO-WALL EXPANSION JOINT		DETAIL NO.
	MAXIMUM WARRANTY: 30 YEARS		U-3B
		THERMOSET UNIVERSAL	

© 2023 Carlisle SynTec a division of Carlisle Construction Materials Incorporated

THERMOSET MEMBRANE EPDM

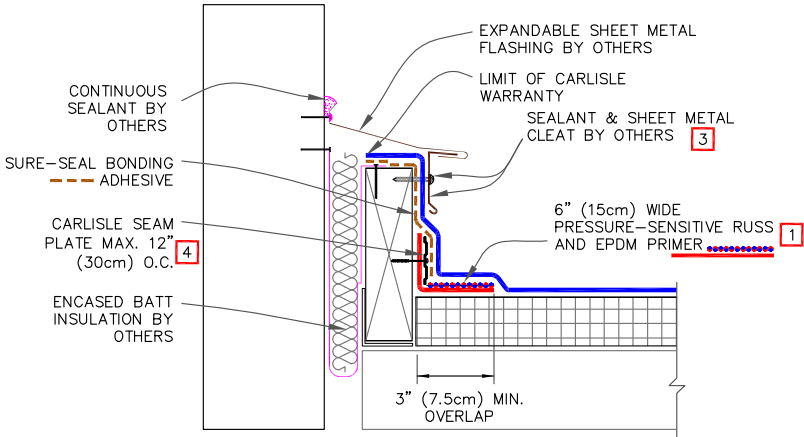

NOTES:

1. PRESSURE-SENSITIVE RUSS MAY BE INSTALLED INTO THE STRUCTURAL DECK. HP FASTENERS AND POLYMER SEAM PLATES ARE REQUIRED ON MECHANICALLY-FASTENED ROOFING SYSTEMS OVER STEEL DECKS.
2. USE [DETAIL U-2C](#) FOR EPDM MEMBRANE SPLICES AT ANGLE CHANGES.
3. SEAL FASTENERS BY APPLYING WATER CUT-OFF MASTIC UNDER THE COUNTER-FLASHING, OR USING EPDM WASHERS, OR CAULKING THE FASTENERS HEAD.
4. ALL OUTSIDE AND INSIDE CORNERS REQUIRE TWO COMPLETE CORNER APPLICATIONS OF PRESSURE-SENSITIVE ELASTOFORM FLASHING AS PER [DETAILS U-15D.1 OR U-15G.1](#).
5. MAXIMUM 6" (15cm) FASTENER SPACING FOR WARRANTY WIND SPEEDS GREATER THAN 90 MPH OR WARRANTIES EXCEEDING 20 YEARS.

	SHEAR/EXPANSION JOINT		DETAIL NO.
	MAXIMUM WARRANTY: 30 YEARS		U-3C
		THERMOSET UNIVERSAL	

© 2023 Carlisle SynTec a division of Carlisle Construction Materials Incorporated

THERMOSET MEMBRANE

EPDM

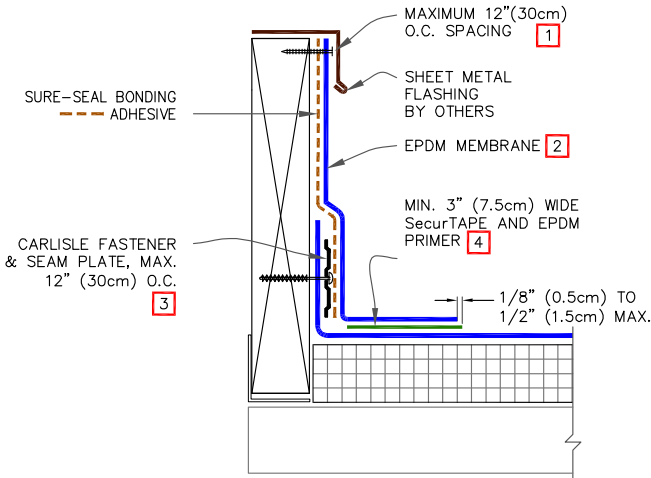

NOTES:

1. WHEN MECHANICAL FASTENERS ARE USED TO PENETRATE THE METAL COUNTER-FLASHING, USE EPDM WASHERS, APPLY WATER CUT-OFF MASTIC UNDER THE COUNTER-FLASHING OR CAULK THE FASTENER HEADS.
2. LAP SEALANT IS REQUIRED ON CUT-EDGES OF REINFORCED MEMBRANE.
3. SEAM PLATES AND FASTENERS MAY BE INSTALLED INTO THE STRUCTURAL DECK AND THEN HP FASTENERS AND POLYMER SEAM PLATES ARE REQUIRED FOR MECHANICALLY-FASTENED ROOFING SYSTEMS OVER STEEL DECKS.
4. MEMBRANE SPLICES SHALL INCORPORATE 6" (15cm) WIDE SecurTAPE FOR PROJECTS WITH 25 AND 30-YEAR WARRANTIES.
5. IF THE VERTICAL SPlice ON THE CURB FLASHING IS NOT LOCATED AT THE CORNER, USE DETAIL **U-2C** FOR EPDM MEMBRANE SPLICES AT ANGLE CHANGES.

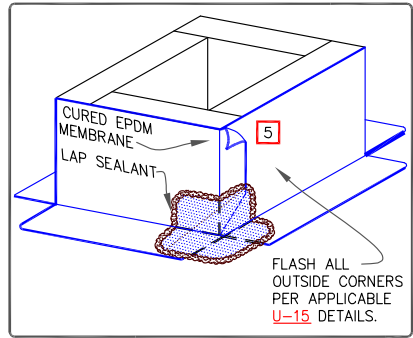

	CURB FLASHING – EPDM MEMBRANE		DETAIL NO.
	MAXIMUM WARRANTY: 30 YEARS		U-5A
		THERMOSET UNIVERSAL	

© 2023 Carlisle SynTec a division of Carlisle Construction Materials Incorporated

THERMOSET MEMBRANE EPDM

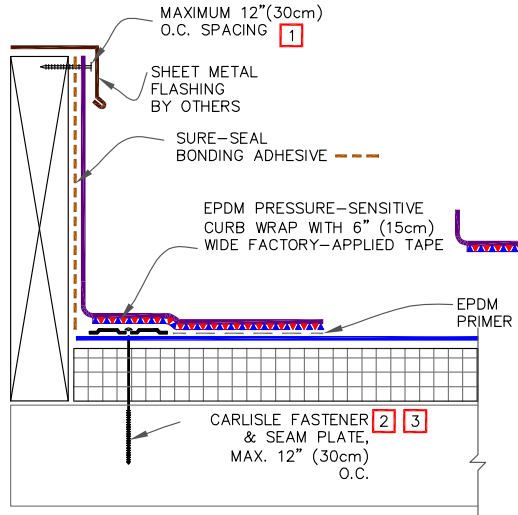

NOTES:

1. WHEN MECHANICAL FASTENERS ARE USED TO PENETRATE THE METAL COUNTER-FLASHING, USE EPDM WASHERS, APPLY WATER CUT-OFF MASTIC UNDER THE COUNTER-FLASHING OR CAULK THE FASTENER HEADS.
2. SEAM PLATES AND FASTENERS MAY BE INSTALLED INTO THE VERTICAL SUBSTRATE.
3. HP FASTENERS AND POLYMER SEAM PLATES ARE REQUIRED FOR MECHANICALLY FASTENED SYSTEMS OVER STEEL DECKS.
4. IF THE VERTICAL SPLICE ON THE CURB FLASHING IS NOT LOCATED AT THE CORNER, USE DETAIL **U-2C** FOR EPDM MEMBRANE SPLICES AT ANGLE CHANGES.

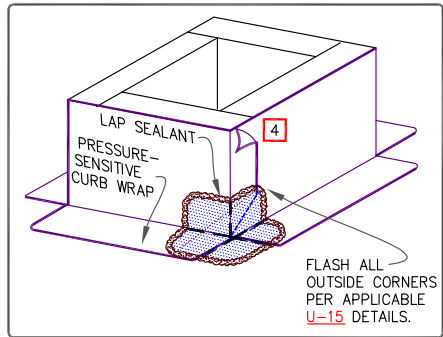

	CURB FLASHING – PRESSURE-SENSITIVE CURB WRAP WITH 6" TAPE		DETAIL NO.
	MAXIMUM WARRANTY: 30 YEARS		U-5B
		THERMOSET UNIVERSAL	

© 2023 Carlisle SynTec a division of Carlisle Construction Materials Incorporated

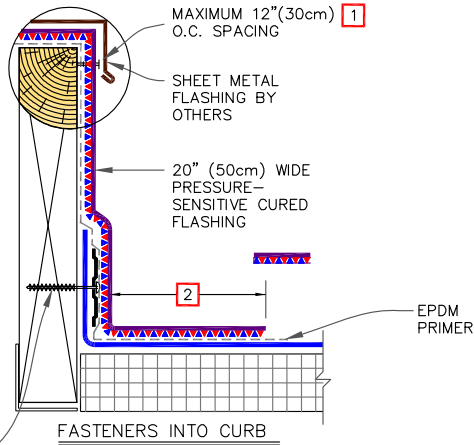

CARLISLE FASTENER & SEAM PLATES, MAX. 12" (30cm) O.C.

NOTES:

1. WHEN MECHANICAL FASTENERS ARE USED TO PENETRATE THE METAL COUNTER-FLASHING, USE EPDM WASHERS, APPLY WATER CUT-OFF MASTIC UNDER THE COUNTER-FLASHING OR CAULK THE FASTENER HEADS.
2. 3" (7.5cm) FOR UP TO 20 YEARS AND 6" (15cm) FOR 25/30 YEARS.
3. HP FASTENERS AND POLYMER SEAM PLATES ARE REQUIRED FOR MECHANICALLY-FASTENED ROOFING SYSTEMS OVER STEEL DECKS.
4. IF THE VERTICAL SPLICE ON THE CURB FLASHING IS NOT LOCATED AT THE CORNER, USE DETAIL U-2C FOR EPDM MEMBRANE SPLICES AT ANGLE CHANGES.

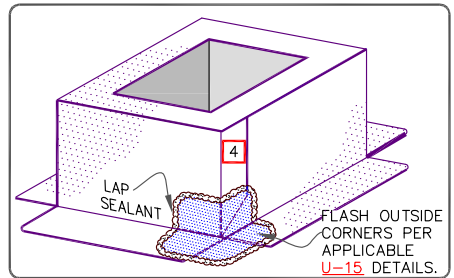
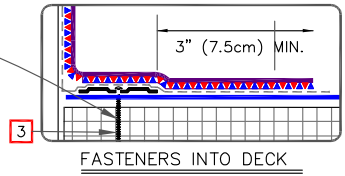

	CURB FLASHING – WITH 20" PRESSURE-SENSITIVE CURED FLASHING		DETAIL NO.
	MAXIMUM WARRANTY: 30 YEARS		U-5C
		THERMOSET UNIVERSAL	

© 2023 Carlisle SynTec a division of Carlisle Construction Materials Incorporated

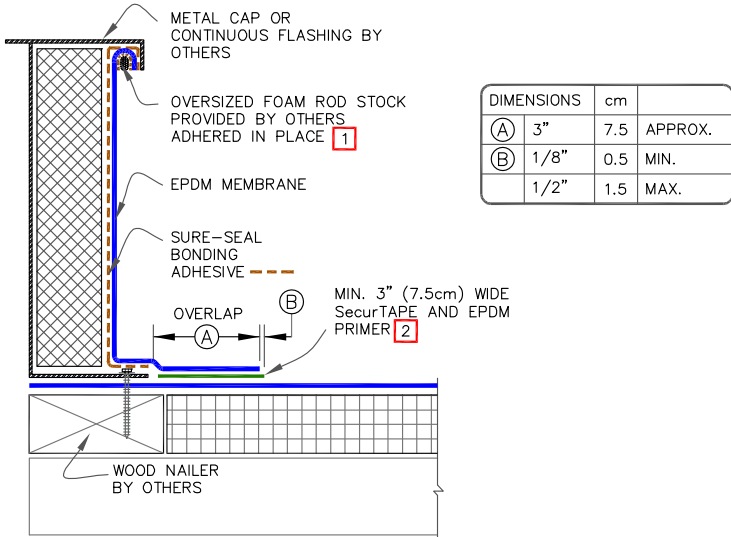

NOTES:

1. LENGTH OF ROD STOCK IS LIMITED TO 4' (1.2m). USE INDIVIDUAL SECTIONS OF ROD STOCK FOR LONGER DIMENSIONS.
2. MEMBRANE SPLICES SHALL INCORPORATE 6" (15cm) WIDE SecurTAPE FOR PROJECTS WITH 25 and 30-YEAR WARRANTIES.
3. WHEN METAL FLANGE IS ON TOP OF MEMBRANE USE DETAIL [U-15F](#) (20 YEAR) OR [U-15G.1](#) (25/30 YEAR) TO ACHIEVE SUFFICIENT COVERAGE AT THE CORNERS.
4. DETAIL IS NOT ACCEPTABLE FOR VIBRATING ROOF TOP UNITS.

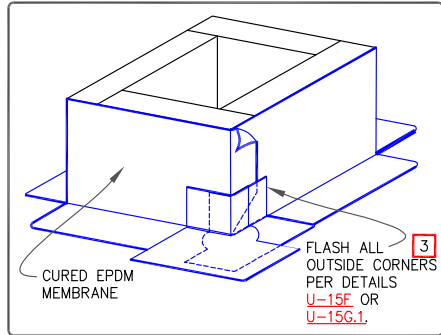

	SELF-FLASHING CURB, ROOF HATCH OR SKYLIGHT		DETAIL NO.
	MAXIMUM WARRANTY: 30 YEARS		U-5D
		THERMOSET UNIVERSAL	

© 2023 Carlisle SynTec a division of Carlisle Construction Materials Incorporated

THERMOSET MEMBRANE

EPDM

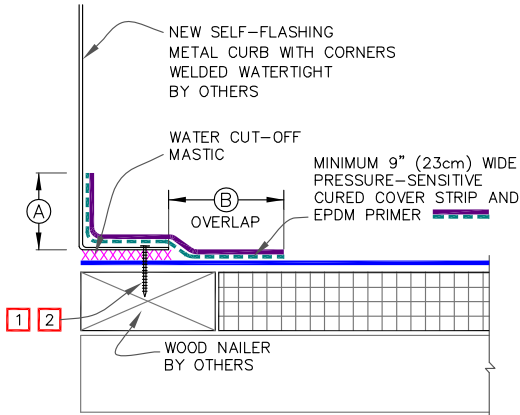

DIMENSIONS		cm	
(A)	2"	5	MIN.
(B)	3"	7.5	APPROX.

NOTES:

1. CONSULT THE RESPECTIVE MANUFACTURER OF THE SELF-FLASHING METAL CURB FOR PROPER SECUREMENT.
2. WATER CUT-OFF MASTIC MUST BE HELD UNDER CONSTANT COMPRESSION.
3. USE [DETAIL U-15F](#) TO ACHIEVE SUFFICIENT COVERAGE OF METAL FLANGE AT CORNERS.
4. IF THE VERTICAL SPLICE ON THE CURB FLASHING IS NOT LOCATED AT THE CORNER, USE [DETAIL U-2C](#) FOR EPDM MEMBRANE SPLICES AT ANGLE CHANGES.

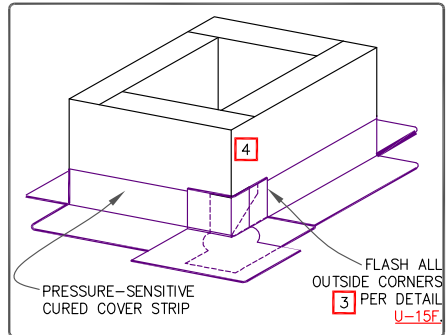

	NEW SELF-FLASHING METAL CURB		DETAIL NO.
	MAXIMUM WARRANTY: 20 YEARS		U-5E
		THERMOSET UNIVERSAL	

© 2023 Carlisle SynTec a division of Carlisle Construction Materials Incorporated

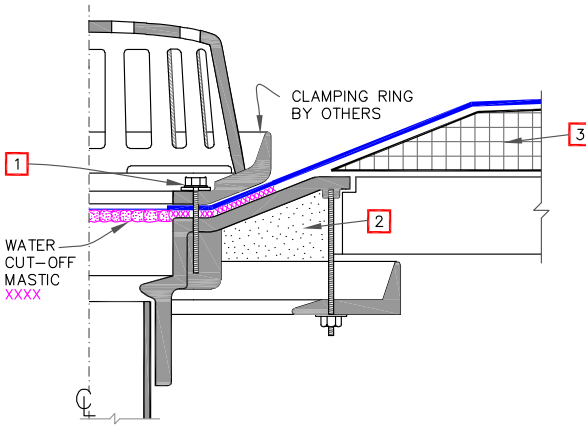

NOTES:

1. ALL BOLTS OR CLAMPS MUST BE IN PLACE TO PROVIDE CONSTANT COMPRESSION ON WATER CUT-OFF MASTIC.
2. REMOVE EXISTING LEAD, FLASHING MATERIAL & ENSURE THE DRAIN RING IS COMPLETELY CLEAN DOWN TO BARE METAL.
3. INSULATION TAPER SHALL NOT BE GREATER THAN 6" (15cm) IN 12" (30cm) HORIZONTAL. REINFORCED EPDM IS LIMITED TO A TAPER LESS THAN 3" (7.5CM) PER FOOT. IF GREATER USE DETAIL [U-6B](#).
4. THE HOLE IN THE MEMBRANE SHALL EXCEED THE DIAMETER OF THE DRAIN PIPE, BUT SHALL BE NO LESS THAN 1/2" (1.5cm) FROM THE ATTACHMENT POINTS OF THE DRAIN CLAMPING RING.
5. FIELD SPLICES MUST BE LOCATED AT LEAST 6" (15cm) OUTSIDE THE DRAIN SUMP.
6. ROOF DRAIN SIZE AND NUMBER OF DRAINS SHALL BE IN ACCORDANCE WITH THE LOCAL CODES.

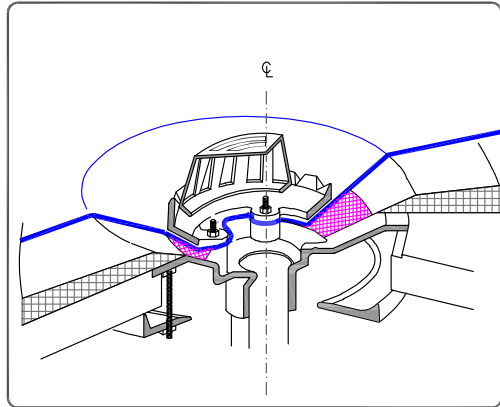
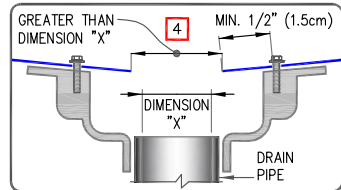

	ROOF DRAIN		DETAIL NO.
	MAXIMUM WARRANTY: 30 YEARS		U-6A
		THERMOSET UNIVERSAL	

© 2023 Carlisle SynTec a division of Carlisle Construction Materials Incorporated

THERMOSET MEMBRANE

EPDM

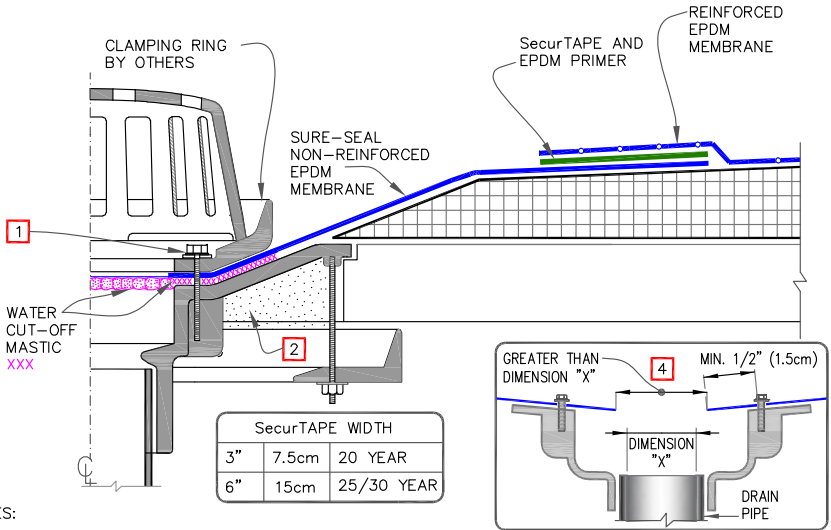

NOTES:

1. ALL BOLTS OR CLAMPS MUST BE IN PLACE TO PROVIDE CONSTANT COMPRESSION ON WATER CUT-OFF MASTIC.
2. REMOVE EXISTING LEAD, FLASHING MATERIAL & ENSURE THE DRAIN RING IS COMPLETELY CLEAN DOWN TO BARE METAL.
3. USE DETAIL **MF-6B** FOR MECHANICALLY-FASTENED SYSTEMS.
4. THE HOLE IN THE MEMBRANE SHALL EXCEED THE DIAMETER OF THE DRAIN PIPE, BUT SHALL BE NO LESS THAN 1/2" (1.5cm) FROM THE ATTACHMENT POINTS OF THE DRAIN CLAMPING RING.
5. ROOF DRAIN SIZE AND NUMBER OF DRAINS SHALL BE IN ACCORDANCE WITH THE LOCAL CODES.
6. FIELD SPLICES MUST BE LOCATED AT LEAST 6" (15cm) OUTSIDE THE DRAIN SUMP.
7. CARLISLE RECOMMENDS THE DRAIN TARGET SPlice BE SHINGLED
 - 7.1. CUT A SQUARE HOLE IN THE FIELD SHEET TO BE AT LEAST 6" (15cm) OUTSIDE THE DRAIN SUMP
 - 7.2. APPLY PRIMER AND SecurTAPE TO THE BOTTOM OF THE FIELD SHEET
 - 7.3. PRIME THE TARGET PIECE OF NR EPDM
 - 7.4. MATE THE TARGET TO THE TAPE
 - 7.5. APPLY BONDING ADHESIVE TO ADHERE FIELD AND TARGET MEMBRANE TO THE SUBSTRATE

	ROOF DRAIN – REINFORCED FIELD SHEET WITH SUMP EXCEEDING 3" PER FOOT		DETAIL NO.
	MAXIMUM WARRANTY: 30 YEARS		U-6B
		THERMOSET UNIVERSAL	

© 2023 Carlisle SynTec a division of Carlisle Construction Materials Incorporated

■ THERMOSET MEMBRANE ■ EPDM ■

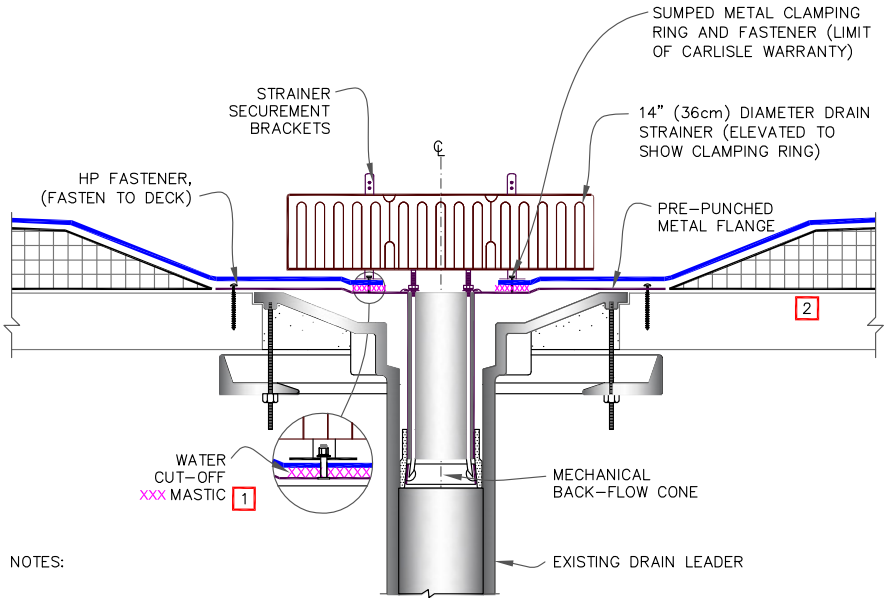

NOTES:

1. ALL BOLTS OR CLAMPS MUST BE IN PLACE TO PROVIDE CONSTANT COMPRESSION ON WATER CUT-OFF MASTIC.
2. INSULATION TAPER SHALL NOT BE GREATER THAN 6" (15cm) IN 12" (30cm) HORIZONTAL.
3. THE HOLE IN THE MEMBRANE SHALL EXCEED THE DIAMETER OF THE DRAIN PIPE, BUT SHALL BE NO LESS THAN 1/2" (1.5cm) FROM THE ATTACHMENT POINTS OF THE DRAIN CLAMPING RING.
4. FIELD SPICES MUST BE LOCATED AT LEAST 6" (15cm) OUTSIDE THE DRAIN SUMP.
5. ROOF DRAIN SIZE AND NUMBER OF DRAINS SHALL BE IN ACCORDANCE WITH THE LOCAL CODES.

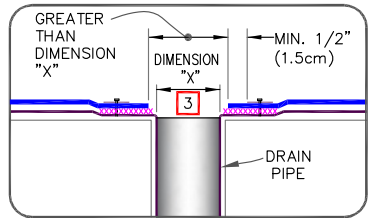

	SURE-SEAL INSERT DRAIN		DETAIL NO.
	MAXIMUM WARRANTY: 30 YEARS		U-6C
		THERMOSET UNIVERSAL	

© 2023 Carlisle SynTec a division of Carlisle Construction Materials Incorporated

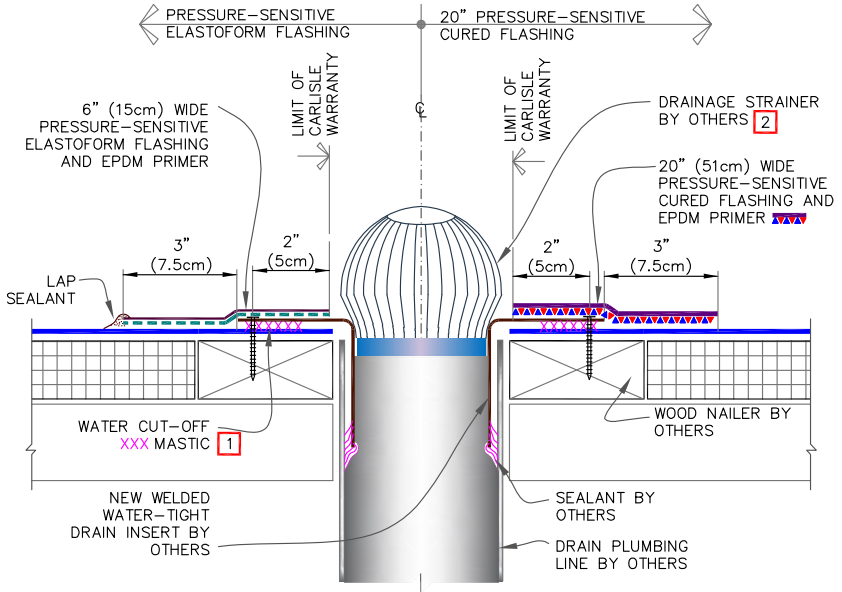

THERMOSET MEMBRANE

EPDM



NOTES:

1. WATER CUT-OFF MASTIC MUST BE UNDER CONSTANT COMPRESSION.
2. CONSULT SPECIFIER OR APPLICABLE CODES FOR ADEQUATE DRAINAGE STRAINER TO AVOID PONDING WATER. DO NOT RESTRICT WATER FLOW.
3. FOR PROJECTS WITH 25 AND 30-YEAR WARRANTIES, THE DRAIN INSERT FLANGE MUST BE OVERLAID WITH TWO LAYERS OF PRESSURE-SENSITIVE FLASHING. THE BOTTOM LAYER SHALL BE 6" (15cm) WIDE PRESSURE-SENSITIVE ELASTOFORM OR CURED COVER STRIP COVERED WITH A 9" (23cm) WIDE TOP LAYER OF PRESSURE-SENSITIVE ELASTOFORM FLASHING. SEAL TOP LAYER WITH CONTINUOUS LAP SEALANT.

	INSERT DRAIN THROUGH DECK		DETAIL NO.
	MAXIMUM WARRANTY: 30 YEARS		U-6D
		THERMOSET UNIVERSAL	

© 2023 Carlisle SynTec a division of Carlisle Construction Materials Incorporated

THERMOSET MEMBRANE EPDM

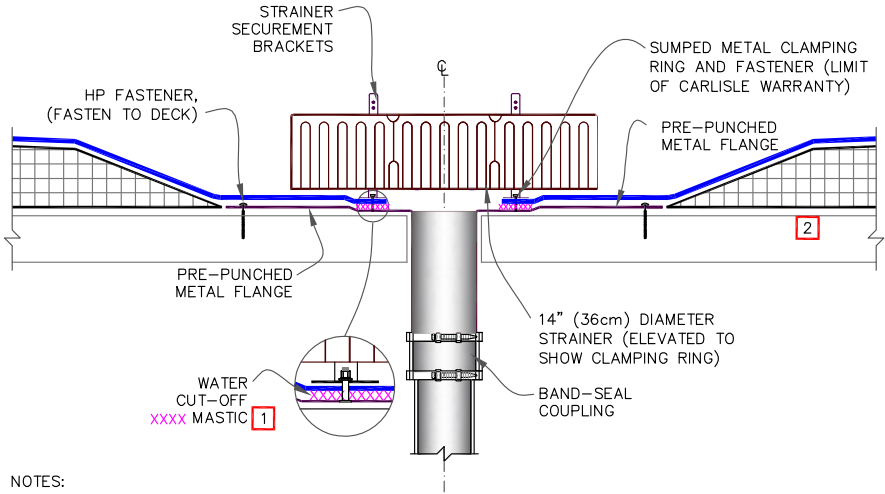

NOTES:

1. ALL BOLTS OR CLAMPS MUST BE IN PLACE TO PROVIDE CONSTANT COMPRESSION ON WATER CUT-OFF MASTIC.
2. INSULATION TAPER SHALL NOT BE GREATER THAN 6" (15cm) IN 12" (30cm) HORIZONTAL.
3. THE HOLE IN THE MEMBRANE SHALL EXCEED THE DIAMETER OF THE DRAIN PIPE, BUT SHALL BE NO LESS THAN 1/2" (1.5cm) FROM THE ATTACHMENT POINTS OF THE DRAIN CLAMPING RING.
4. FIELD SPICES MUST BE LOCATED AT LEAST 6" (15cm) OUTSIDE THE DRAIN SUMP.
5. ROOF DRAIN SIZE AND NUMBER OF DRAINS SHALL BE IN ACCORDANCE WITH THE LOCAL CODES.

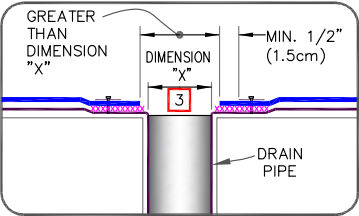

	SURE-SEAL ADD-ON DRAIN		DETAIL NO.
	MAXIMUM WARRANTY: 30 YEARS		U-6E
		THERMOSET UNIVERSAL	

© 2023 Carlisle SynTec a division of Carlisle Construction Materials Incorporated

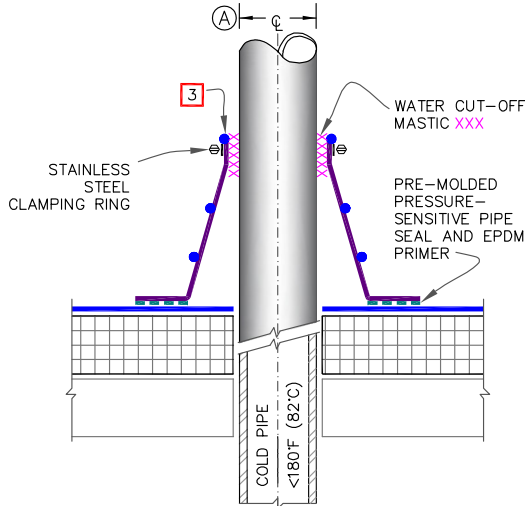

NOTES:

1. REMOVE ALL LEAD AND OTHER FLASHING BEFORE INSTALLING PRESSURE-SENSITIVE PIPE SEAL.
2. TEMPERATURE OF PIPE PENETRATION MUST NOT EXCEED 180°F (82°C).
3. PRE-MOLDED PIPE FLASHING MUST HAVE RIB INTACT AT THE TOP EDGE REGARDLESS OF PIPE DIAMETER.
4. DECK FLANGES OF THE PRESSURE-SENSITIVE PIPE SEAL SHALL NOT BE OVERLAPPED, CUT OR APPLIED OVER ANY ANGLE CHANGE.
5. USE DETAIL [U-8A.1](#) WHEN PIPE BOOT INTERSECTS A SPLICE ON 25/30 YEAR WARRANTIES.
6. ON MECHANICALLY-FASTENED ROOFING SYSTEMS, REFER TO [DETAIL MF-8A](#).

DIMENSIONS		cm	
(A)	1/2"	1.5	TO
	6"	15	
(B)	3"	7.5	

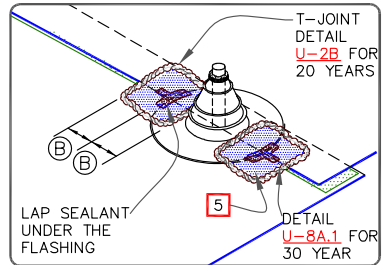

	PRESSURE-SENSITIVE PIPE SEAL		DETAIL NO.
	MAXIMUM WARRANTY: 30 YEARS		U-8A
		THERMOSET UNIVERSAL	

© 2023 Carlisle SynTec a division of Carlisle Construction Materials Incorporated

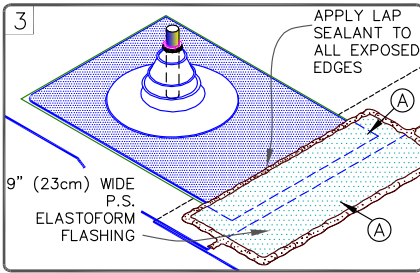
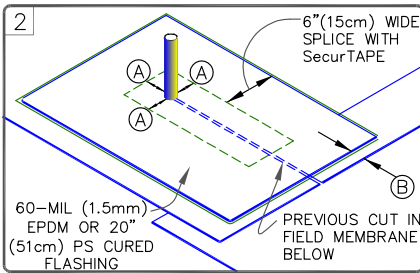
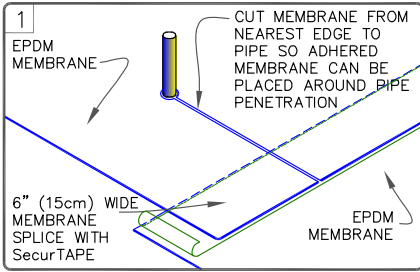

NOTES:

1. THIS DETAIL FOR USE WHEN A RELIEF CUT OR MEMBRANE SPLICE IS PRESENT AT THE PIPE SEAL. USE DETAIL [U-8A](#) WHEN NO CUT OR SPLICE IS PRESENT.
2. REMOVE ALL LEAD AND OTHER FLASHING BEFORE INSTALLING PRESSURE-SENSITIVE PIPE SEAL.
3. PIPE SEAL MUST HAVE INTACT RIB AT TOP EDGE, REGARDLESS OF PIPE DIAMETER.
4. DECK FLANGES OF THE MOLDED PIPE SEAL SHALL NOT BE OVERLAPPED, CUT OR APPLIED OVER ANY ANGLE CHANGE.
5. ON MECHANICALLY FASTENED ROOFING SYSTEMS REFER TO DETAIL [MF-8A.1](#).

DIMENSIONS	cm	
(A)	3"	7.5 MIN.
(B)	1"	2.5 MIN.

	PRESSURE-SENSITIVE PIPE SEAL WITH 90-MIL MEMBRANE OR 25 / 30 YEAR WARRANTIES		DETAIL NO.
	MAXIMUM WARRANTY: 30 YEARS		U-8A.1
		THERMOSET UNIVERSAL	

© 2023 Carlisle SynTec a division of Carlisle Construction Materials Incorporated

THERMOSET MEMBRANE EPDM

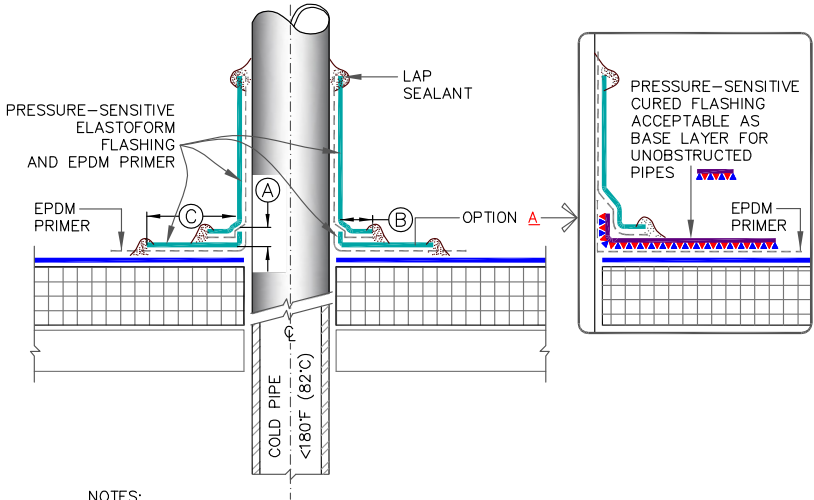

NOTES:

1. REMOVE ALL LEAD AND OTHER FLASHING BEFORE INSTALLING FIELD-FABRICATED FLASHING.
2. TEMPERATURE OF PIPE PENETRATION MUST NOT EXCEED 180°F (82°C).
3. ACCEPTABLE WITH SQUARE OR RECTANGULAR STRUCTURAL TUBING WITH ROUNDED CORNERS UP TO 12”(30cm). USE [DETAIL U-5](#) IF GREATER THAN 12” (30cm).
4. IN COLDER TEMPERATURES, A HEAT GUN MUST BE USED WHEN FORMING PRESSURE-SENSITIVE ELASTOFORM OR CURED FLASHING.
5. ON MECHANICALLY FASTENED ROOFING SYSTEMS. REFER TO [DETAIL MF-8B](#).
6. MEMBRANE SECUREMENT IS REQUIRED AROUND ALL ROUND PIPE PENETRATIONS GREATER THAN 18” (46cm) IN DIAMETER.

DIMENSIONS		cm	
(A)	1/2”	1.5	MIN.
(B)	1”	2.5	MIN.
(C)	3”	7.5	MIN.

	FIELD FABRICATED PIPE WRAP		DETAIL NO.
	MAXIMUM WARRANTY: 20 YEARS		U-8B
		THERMOSET UNIVERSAL	

© 2023 Carlisle SynTec a division of Carlisle Construction Materials Incorporated

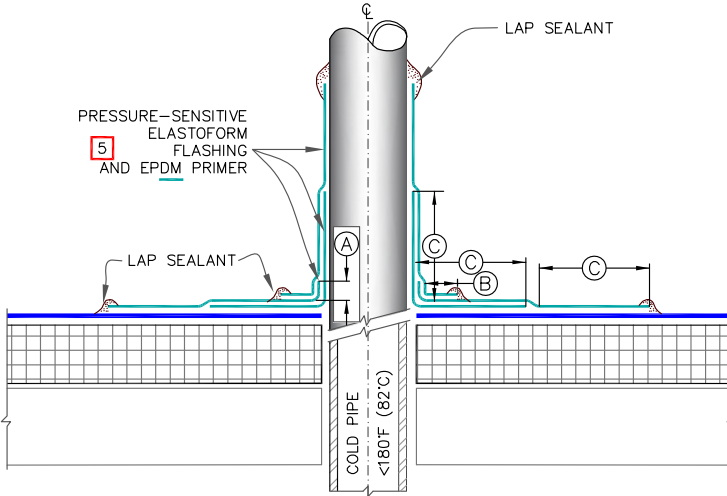

NOTES:

1. REMOVE ALL LEAD AND OTHER FLASHING BEFORE INSTALLING FIELD-FABRICATED FLASHING.
2. TEMPERATURE OF PIPE PENETRATION MUST NOT EXCEED 180°F (82°C).
3. PIPE FLASHING MAY BE USED WITH SQUARE OR RECTANGULAR STRUCTURAL TUBING WITH ROUNDED CORNERS.
4. FOR STRUCTURAL STEEL TUBING GREATER THAN 12" (30cm) ACROSS, USE [DETAIL\(S\) U-5](#).
5. IN COLDER TEMPERATURES, A HEAT GUN MUST BE USED WHEN FORMING PRESSURE-SENSITIVE ELASTOFORM FLASHING.
6. ON MECHANICALLY FASTENED ROOFING SYSTEMS, REFER TO [DETAIL MF-8B.1](#).
7. MEMBRANE SECUREMENT IS REQUIRED AROUND ALL ROUND PIPE PENETRATIONS GREATER THAN 18" (46cm) IN DIAMETER.

DIMENSIONS	cm	
(A)	1/2"	1.5 MIN.
(B)	1"	2.5 MIN.
(C)	3"	7.5 MIN.

	FIELD FABRICATED PIPE WRAP (25/30 YEAR WARRANTIES)		DETAIL NO.
	MAXIMUM WARRANTY: 30 YEARS		U-8B.1
		THERMOSET UNIVERSAL	

© 2023 Carlisle SynTec a division of Carlisle Construction Materials Incorporated

THERMOSET MEMBRANE

EPDM

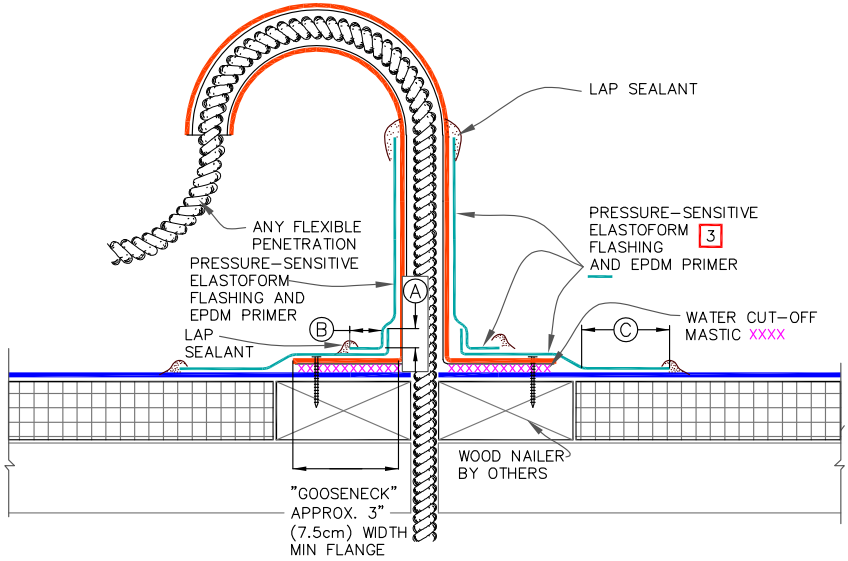

NOTES:

1. REMOVE ALL LEAD AND OTHER FLASHING BEFORE INSTALLING FIELD-FABRICATED PIPE SEAL.
2. TEMPERATURE OF PENETRATION MUST NOT EXCEED 180°F (82°C).
3. IN COLDER TEMPERATURES, A HEAT GUN MUST BE USED WHEN FORMING PRESSURE-SENSITIVE ELASTOFORM FLASHING.

DIMENSIONS		cm	
(A)	1/2"	1.5	MIN.
(B)	1"	2.5	MIN.
(C)	3"	7.5	MIN.

	FLEXIBLE PENETRATION		DETAIL NO.
	MAXIMUM WARRANTY: 20 YEARS		U-8C
		THERMOSET UNIVERSAL	

© 2023 Carlisle SynTec a division of Carlisle Construction Materials Incorporated

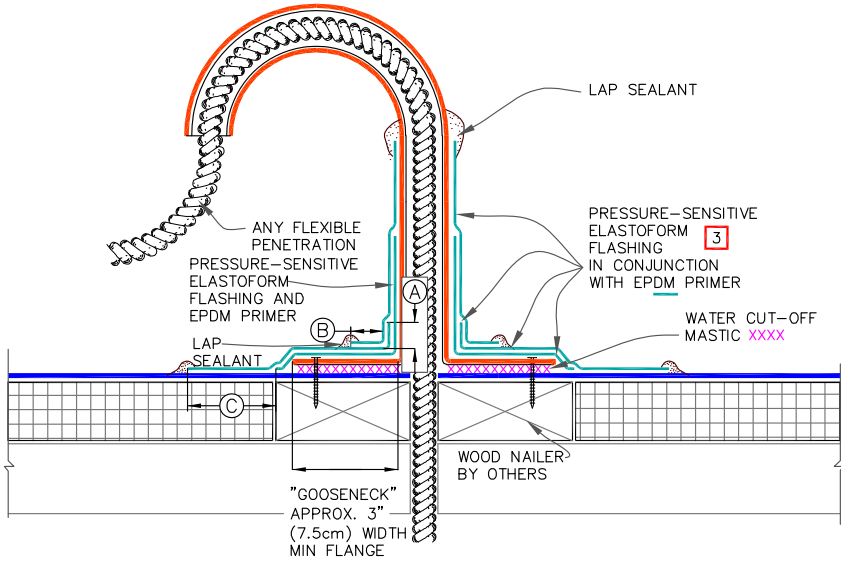

NOTES:

1. REMOVE ALL LEAD AND OTHER FLASHING BEFORE INSTALLING FIELD-FABRICATED PIPE SEAL.
2. TEMPERATURE OF PENETRATION MUST NOT EXCEED 180°F (82°C).
3. IN COLDER TEMPERATURES, A HEAT GUN MUST BE USED WHEN FORMING PRESSURE-SENSITIVE ELASTOFORM FLASHING.

DIMENSIONS	cm	
(A)	1/2"	1.5 MIN.
(B)	1"	2.5 MIN.
(C)	3"	7.5 MIN.

	FLEXIBLE PENETRATION (25/30 YEAR WARRANTIES)		DETAIL NO.
	MAXIMUM WARRANTY: 30 YEARS		U-8C.1
		THERMOSET UNIVERSAL	

© 2023 Carlisle SynTec a division of Carlisle Construction Materials Incorporated

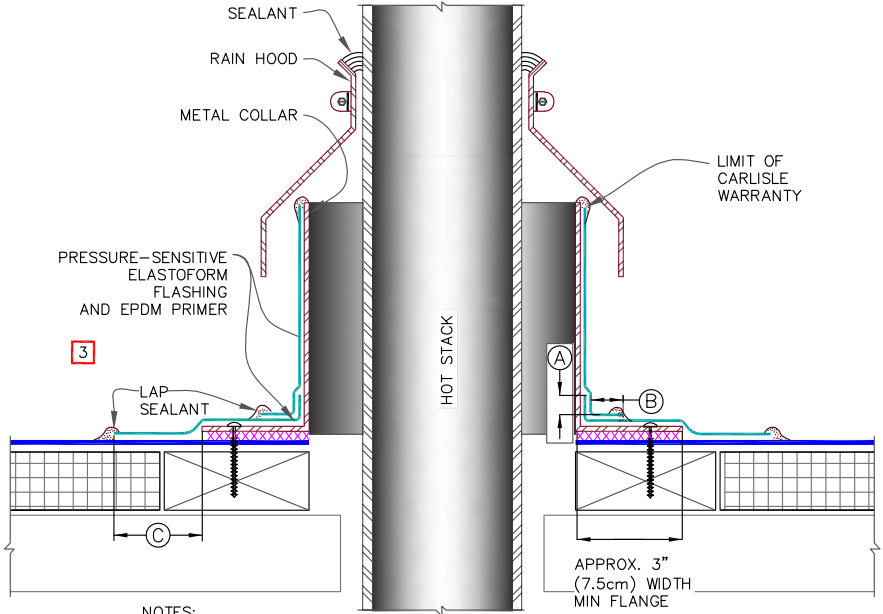

NOTES:

1. REMOVE ALL LEAD AND OTHER FLASHING BEFORE INSTALLING FIELD FABRICATED PIPE SEAL.
2. TEMPERATURE OF METAL COLLAR MUST NOT EXCEED 180°F (82°C).
3. IN COLDER TEMPERATURES, A HEAT GUN MUST BE USED WHEN FORMING PRESSURE-SENSITIVE ELASTOFORM FLASHING.

DIMENSIONS		cm
(A)	1/2"	1.5 MIN.
(B)	1"	2.5 MIN.
(C)	3"	7.5 MIN.

	FIELD FABRICATED HOT STACK		DETAIL NO.
	MAXIMUM WARRANTY: 20 YEARS		U-8D
		THERMOSET UNIVERSAL	

© 2023 Carlisle SynTec a division of Carlisle Construction Materials Incorporated

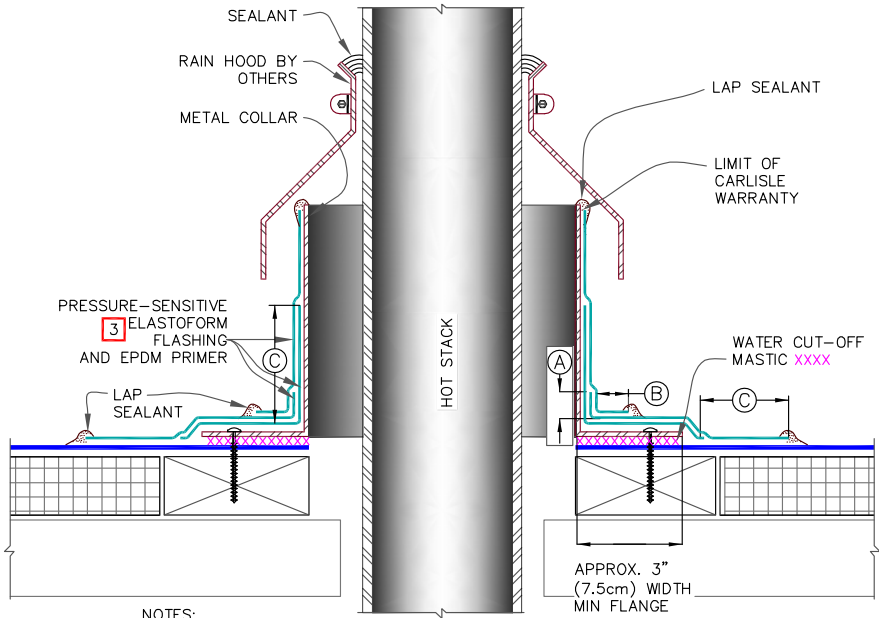

NOTES:

1. REMOVE ALL LEAD AND OTHER FLASHING BEFORE INSTALLING FIELD FABRICATED PIPE SEAL.
2. TEMPERATURE OF METAL COLLAR MUST NOT EXCEED 180°F (82°C).
3. IN COLDER TEMPERATURES, A HEAT GUN MUST BE USED WHEN FORMING PRESSURE-SENSITIVE ELASTOFORM FLASHING.

DIMENSIONS		cm	
(A)	1/2"	1.5	MIN.
(B)	1"	2.5	MIN.
(C)	3"	7.5	MIN.



FIELD FABRICATED HOT STACK
(25/30 YEAR WARRANTIES)

MAXIMUM WARRANTY: 30 YEARS



DETAIL NO.

U-8D.1

THERMOSET UNIVERSAL

THERMOSET MEMBRANE

EPDM

9A MECHANICAL TERMINATION WITH COUNTER FLASHING

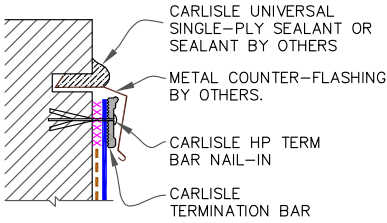

NOTES:

1. APPLY ON HARD SMOOTH SURFACE ONLY; NOT FOR USE ON EXPOSED WOOD.
2. DO NOT WRAP TERMINATION BAR AROUND CORNERS.
3. DETAIL 9E MUST BE USED AT VERTICAL JOINTS IN PANEL WALLS.

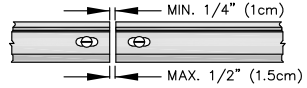

MAXIMUM WARRANTY: 30 YEARS

9B SHEET METAL COPING BY OTHERS

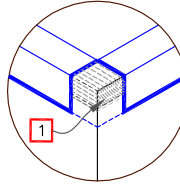
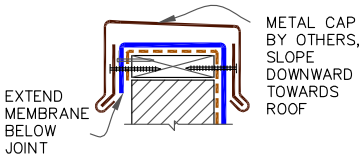

NOTE:

1. MEMBRANE MUST BE EXTENDED TO CORNERS TO PROVIDE COMPLETE COVERAGE OF THE TOP WALL SURFACE.

MAXIMUM WARRANTY: 30 YEARS

9C COUNTER FLASHING TERMINATION

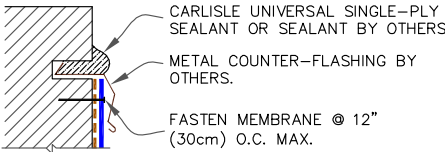

NOTE:

1. WHEN MECHANICAL FASTENERS ARE USED TO PENETRATE THE METAL COUNTER-FLASHING, USE EPDM WASHERS, APPLY WATER CUT-OFF MASTIC UNDER THE COUNTER-FLASHING OR CAULK THE FASTENER HEADS.

MAXIMUM WARRANTY: 10 YEARS

9D MECHANICAL TERMINATION

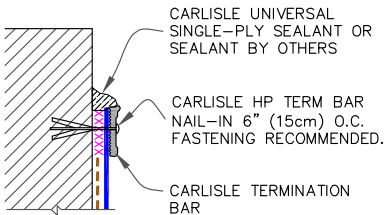

NOTES:

1. APPLY ON HARD SMOOTH SURFACE ONLY; NOT FOR USE ON EXPOSED WOOD.
2. DO NOT WRAP TERMINATION BAR AROUND CORNERS.
3. DETAIL 9E MUST BE USED AT VERTICAL JOINTS IN PANEL WALLS.

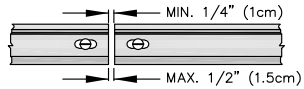

MAXIMUM WARRANTY: 20 YEARS

--- APPLICABLE BONDING ADHESIVE

xxx WATER CUT-OFF MASTIC- MUST BE HELD UNDER CONSTANT COMPRESSION.

	MEMBRANE TERMINATIONS PAGE 1 OF 2		DETAIL NO.
	MAXIMUM WARRANTY: 10-30 YEARS		U-9
		THERMOSET UNIVERSAL	

THERMOSET MEMBRANE

EPDM

9E MECHANICAL TERMINATION AT VERTICAL JOINTS

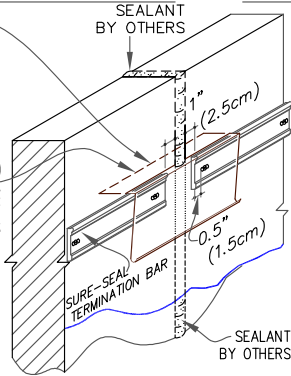
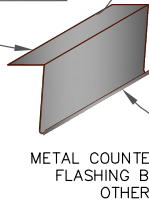
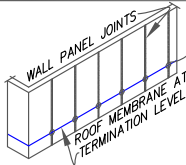

NOTES:

1. THIS DETAIL MUST BE USED FOR ANY PROJECT REGARDLESS OF WARRANTY.
2. CONTINUOUS COUNTER FLASHING REQUIRED FOR WARRANTY PROJECTS EXCEEDING 20-YEARS.
3. VERTICAL JOINTS IN THE PRE-CAST PANEL AS WELL AS ALL GAPS AT THE JUNCTION OF THE TILT-UP PANEL AND ROOF DECK MUST BE FULLY SEALED TO PREVENT AIR INFILTRATION.
4. APPLY ON HARD SMOOTH SURFACE ONLY.

MAXIMUM WARRANTY: 30 YEARS

9F SecurEdge COPING

SecurEdge 200 & 300

- COPING
- 20 GA. GALVANIZED ANCHOR CLIPS @ 6 FEET (183cm) O.C.
- CONCEALED SPLICE PLATE AT EACH JOINT OF COPING
- HEX-HEAD FASTENERS

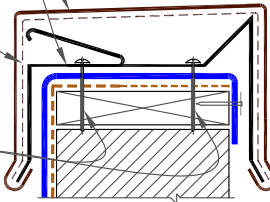

NOTE:

1. MEMBRANE MUST BE EXTENDED AT CORNERS TO PROVIDE COMPLETE COVERAGE OF THE TOP WALL SURFACE. REFER TO **DETAIL U-9B**.

MAXIMUM WARRANTY: 30 YEARS

9G COPING STONE TERMINATION

SEE INSET ON RIGHT

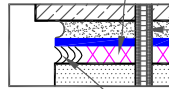
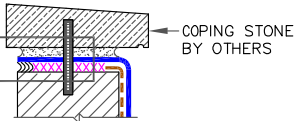

- WATER CUT-OFF MASTIC AROUND DOWEL OR ANCHOR BY OTHERS
- DOWEL OR ANCHOR BY OTHERS
- SEALANT UNDER THE MEMBRANE LIP BY OTHERS

MAXIMUM WARRANTY: 30 YEARS

--- APPLICABLE BONDING ADHESIVE

xxx WATER CUT-OFF MASTIC- MUST BE HELD UNDER CONSTANT COMPRESSION.



MEMBRANE TERMINATIONS PAGE 2 OF 2

MAXIMUM WARRANTY: 30 YEARS



DETAIL NO.

U-9

THERMOSET UNIVERSAL

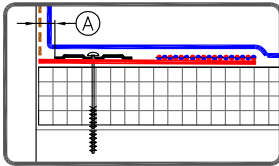

OPTIONAL: SEAM PLATE/FASTENER MAY BE INSTALLED INTO THE STRUCTURAL DECK UP TO 6" (15cm) FROM ANGLE CHANGE.

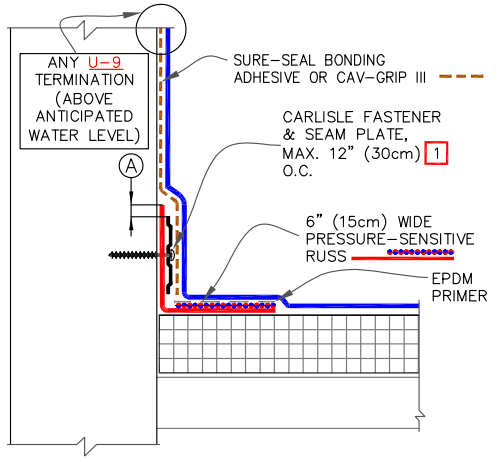

NOTES:

1. FASTENERS AND PLATES ARE REQUIRED AT 6" (15cm) O.C. FOR ADHERED SYSTEMS WITH WARRANTY WIND SPEED COVERAGE GREATER THAN 90 MPH AND FOR ALL PROJECTS WITH WARRANTIES GREATER THAN 20 YEARS. HP FASTENERS AND POLYMER SEAM PLATES ARE REQUIRED OVER STEEL DECKS ON MECHANICALLY FASTENED SYSTEMS.
2. PROJECTS WITH 25 AND 30-YEAR WARRANTIES OR WHEN USING 90-MIL MEMBRANE, REFER TO DETAIL U-2C.
3. FOR CORNERS AND RUSS APPLICATION REFER TO DETAILS U-15A OR U-15B.

DIMENSION	cm
(A) 1/8"-1"	0.5-2.5

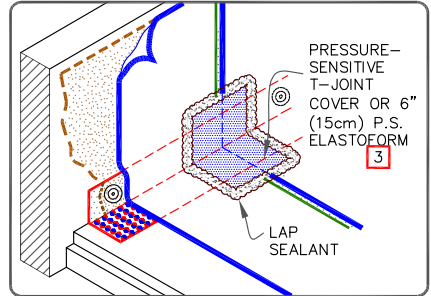

	PARAPET / CURB WITH CONTINUOUS MEMBRANE		DETAIL NO.
	MAXIMUM WARRANTY: 30 YEARS		U-12A
		THERMOSET UNIVERSAL	

© 2023 Carlisle SynTec a division of Carlisle Construction Materials Incorporated

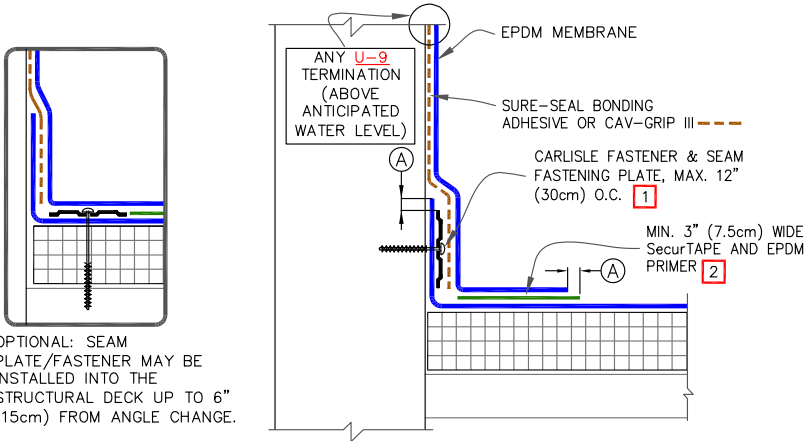

DIMENSIONS	cm	
(A) 1/8"	0.5	TO
1/2"	1.5	MAX.
(B) 3"	7.5	

NOTES:

1. FASTENERS AND PLATES ARE REQUIRED AT 6"(15cm) O.C. FOR ADHERED SYSTEMS WITH WARRANTY WIND SPEED COVERAGE GREATER THAN 90 MPH AND FOR ALL PROJECTS WITH WARRANTIES GREATER THAN 20 YEARS. HP FASTENERS AND POLYMER SEAM PLATES ARE REQUIRED OVER STEEL DECKS ON MECHANICALLY FASTENED SYSTEMS.
2. USE 6" (15cm) WIDE SecurTAPE FOR 25/30 YEAR WARRANTIES. LAP SEALANT IS REQUIRED ON CUT EDGES OF REINFORCED MEMBRANE.
3. PROJECTS WITH 25 AND 30-YEAR WARRANTIES OR WHEN USING 90-MIL MEMBRANE, REFER TO [DETAIL U-2C](#).

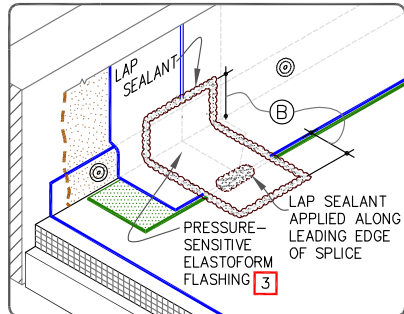

	PARAPET / CURB WITH SEPARATE MEMBRANE FLASHING		DETAIL NO.
	MAXIMUM WARRANTY: 30 YEARS		U-12B
		THERMOSET UNIVERSAL	

© 2023 Carlisle SynTec a division of Carlisle Construction Materials Incorporated

THERMOSET MEMBRANE EPDM

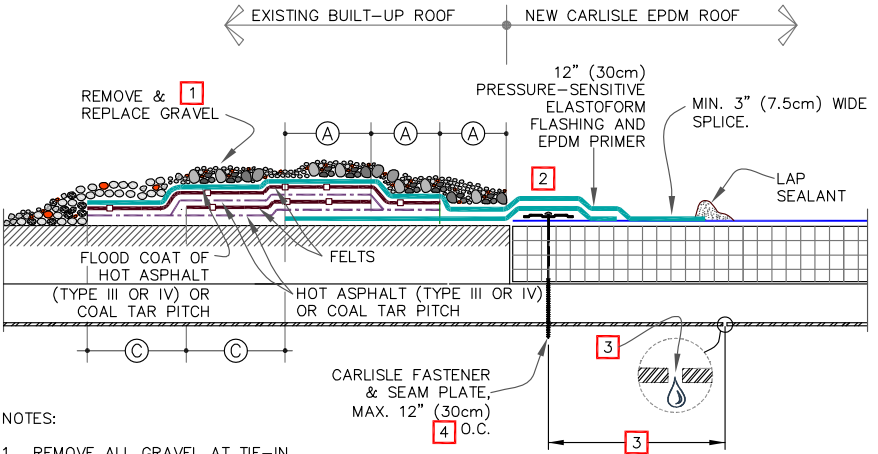

1. REMOVE ALL GRAVEL AT TIE-IN.
2. SPLICE TWO PIECES OR MORE OF ELASTOFORM OR PRESSURE-SENSITIVE ELASTOFORM TOGETHER TO ACHIEVE DESIRED WIDTH.
3. IF FLUTES ARE PERPENDICULAR TO THE TIE-IN DRILL A 3/8" (1cm) DIAMETER WEEP HOLE ON THE BOTTOM FLUTES OF THE STEEL DECK ALONG THE PERIMETER TO THE TIE-IN 6" (15cm) FROM THE SEAM FASTENING PLATE.
4. ON MECHANICALLY FASTENED SYSTEMS, HP FASTENERS AND POLYMER SEAM PLATES ARE REQUIRED OVER STEEL DECKS.
5. IF WATER PONDS OR FLOWS OVER TIE-IN FROM BUR SURFACE, USE [DETAIL U-13B](#).
6. ON BALLASTED SYSTEMS, USE CONCRETE PAVERS TO PREVENT BALLAST MIGRATION.

DIMENSIONS	cm	
(A)	5"	13 MIN.
(B)	2"	5 ± 1/2" (1.5cm)
(C)	6"	15

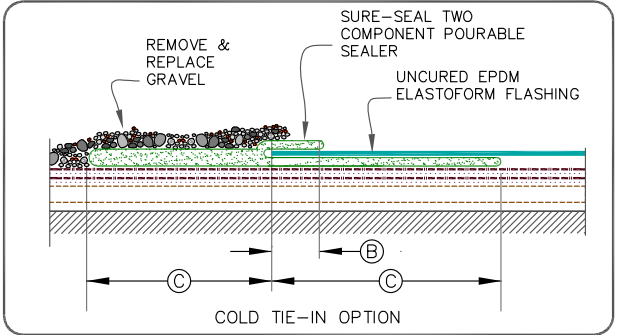

	BUILT-UP ROOFING TIE-IN OVER STEEL ROOF DECK		DETAIL NO.
	MAXIMUM WARRANTY: 30 YEARS		U-13A
		THERMOSET UNIVERSAL	

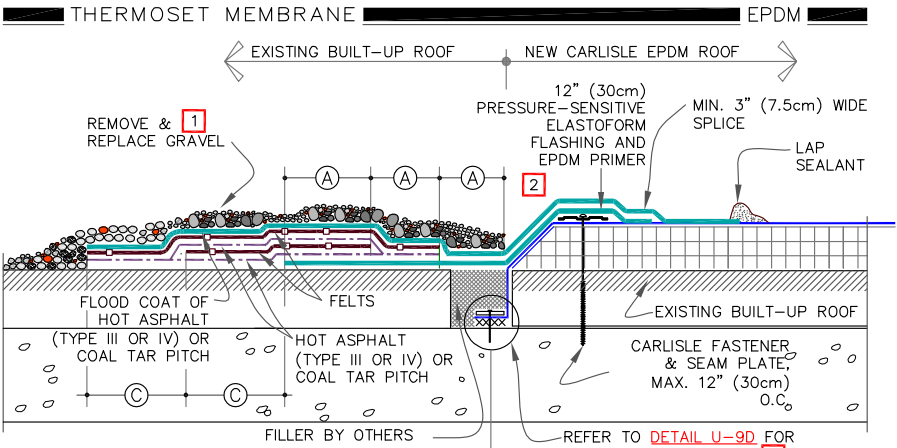

NOTES:

1. REMOVE ALL GRAVEL AT TIE-IN.
2. SPLICE TWO PIECES OF ELASTOFORM OR PRESSURE-SENSITIVE ELASTOFORM TOGETHER TO ACHIEVE DESIRED WIDTH.
3. WATER CUT-OFF MUST BE UNDER CONSTANT COMPRESSION.
4. CARLISLE IS NOT RESPONSIBLE FOR DAMAGE TO THE BUILT-UP ROOF OR STRUCTURAL DECK RESULTING FROM PONDED WATER; THIS DETAIL APPLIES TO RE-ROOFING WHEN A TEAR-OFF IS NOT SPECIFIED AND WAS DESIGNED TO PREVENT MIGRATION OF WATER INTO THE NEW ROOFING SYSTEM.
5. ON BALLASTED SYSTEMS, USE CONCRETE PAVERS TO PREVENT BALLAST MIGRATION.

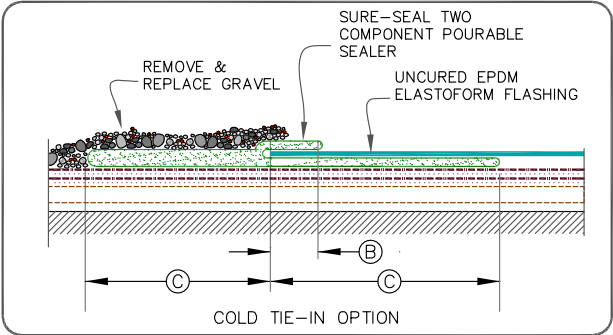

DIMENSIONS	cm	
(A)	5" 13	MIN.
(B)	2" 5	± 1/2" (1.5cm)
(C)	6" 15	

	BUILT-UP ROOFING TIE-IN OVER CONCRETE ROOF DECK		DETAIL NO.
	MAXIMUM WARRANTY: 30 YEARS		U-13B
		THERMOSET UNIVERSAL	

© 2023 Carlisle SynTec a division of Carlisle Construction Materials Incorporated

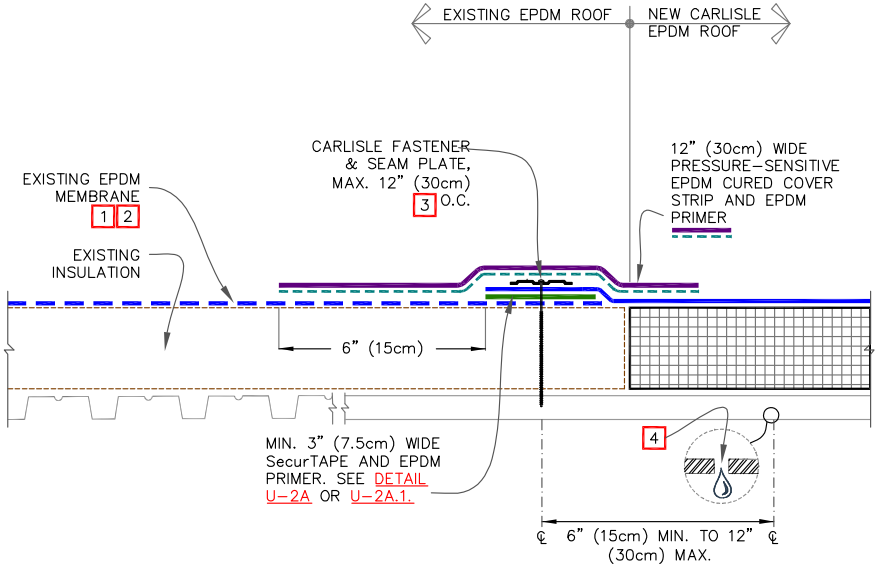

THERMOSET MEMBRANE

EPDM



NOTES:

1. CONTACT MANUFACTURER OF EXISTING EPDM MEMBRANE ROOFING SYSTEM TO VERIFY ACCEPTANCE OF TIE-IN AND TO NOT VOID EXISTING WARRANTY.
2. PRIOR TO SPLICING, CLEAN EXISTING EPDM MEMBRANE BY SCRUBBING THE SPLICE AREA WITH WEATHERED MEMBRANE CLEANER AND ALLOW TO DRY.
3. ON MECHANICALLY FASTENED SYSTEMS, HP FASTENERS AND POLYMER SEAM PLATES ARE REQUIRED OVER STEEL DECKS.
4. IF FLUTES ARE PERPENDICULAR TO THE TIE-IN DRILL A 3/8" (1cm) DIAMETER WEEP HOLE INTO THE BOTTOM FLUTES OF THE STEEL DECK ALONG THE PERIMETER OF THE TIE-IN 6" (15cm) MINIMUM TO 12" (30cm) MAXIMUM FROM THE SEAM FASTENING PLATE.

	TIE-IN TO EXISTING EPDM MEMBRANE		DETAIL NO.
	MAXIMUM WARRANTY: 30 YEARS		U-13C
		THERMOSET UNIVERSAL	

© 2023 Carlisle SynTec a division of Carlisle Construction Materials Incorporated

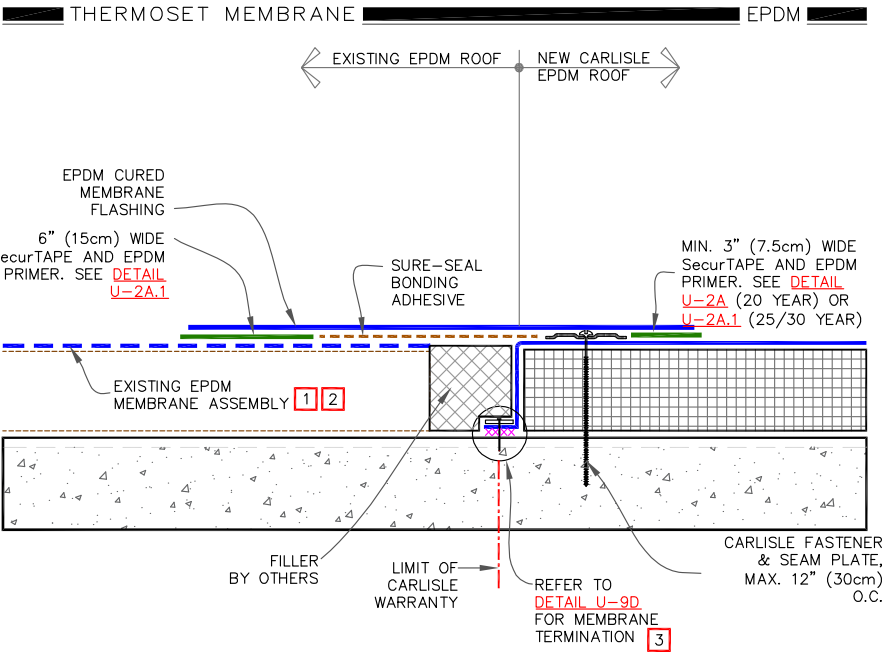

NOTES:

- CONTACT MANUFACTURER OF EXISTING EPDM MEMBRANE ROOFING SYSTEM TO VERIFY ACCEPTANCE OF TIE-IN AND TO NOT VOID EXISTING WARRANTY.
- PRIOR TO SPLICING, CLEAN EXISTING EPDM MEMBRANE BY SCRUBBING THE SPLICE AREA WITH WEATHERED MEMBRANE CLEANER; ALLOW TO DRY.
- WATER CUT-OFF MASTIC MUST BE HELD UNDER CONSTANT COMPRESSION. WHEN RE-ROOFING OVER PRE-CAST CONCRETE, APPLY LIBERAL BEAD OF WATER CUT-OFF MASTIC IN THE JOINTS TO PREVENT MOISTURE MIGRATION.

	EPDM TIE-IN OVER CONCRETE DECK		DETAIL NO.
	MAXIMUM WARRANTY: 30 YEARS		U-13D
		THERMOSET UNIVERSAL	

© 2023 Carlisle SynTec a division of Carlisle Construction Materials Incorporated

THERMOSET MEMBRANE EPDM

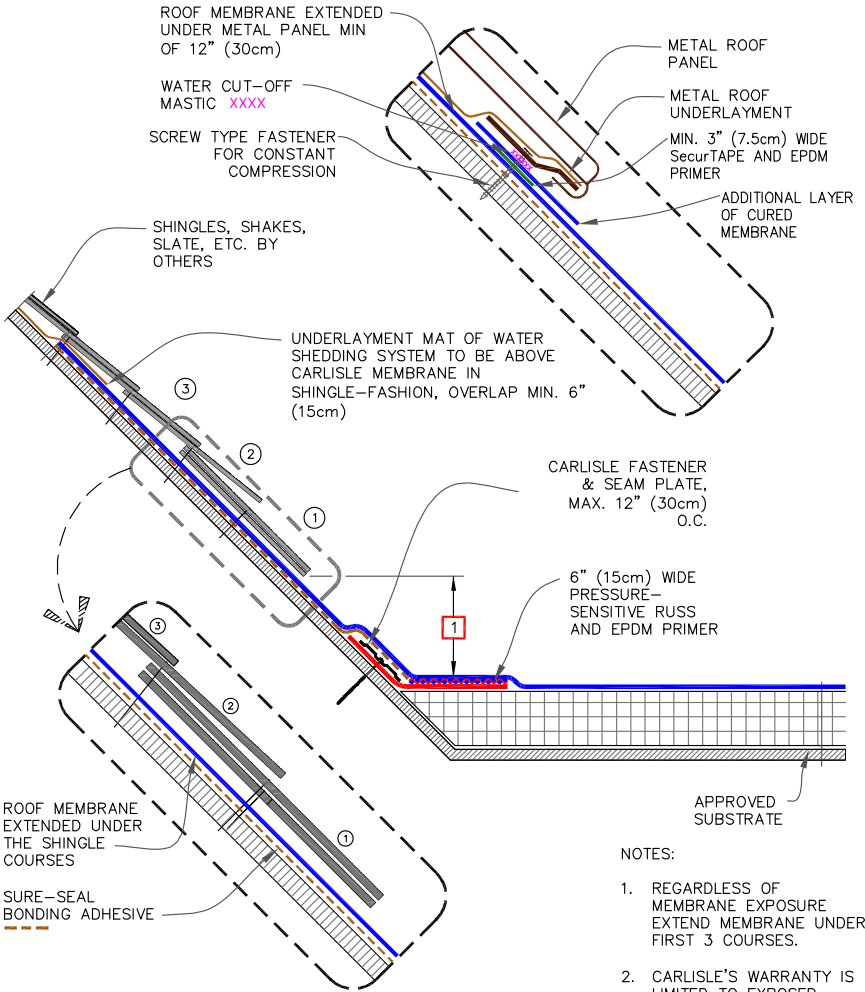

	TIE-IN SHINGLED OR METAL PANEL ROOF		DETAIL NO.
	MAXIMUM WARRANTY: 30 YEARS		U-13E
		THERMOSET UNIVERSAL	

© 2023 Carlisle SynTec a division of Carlisle Construction Materials Incorporated

■■■■ THERMOSET MEMBRANE ■■■■ EPDM ■■■■

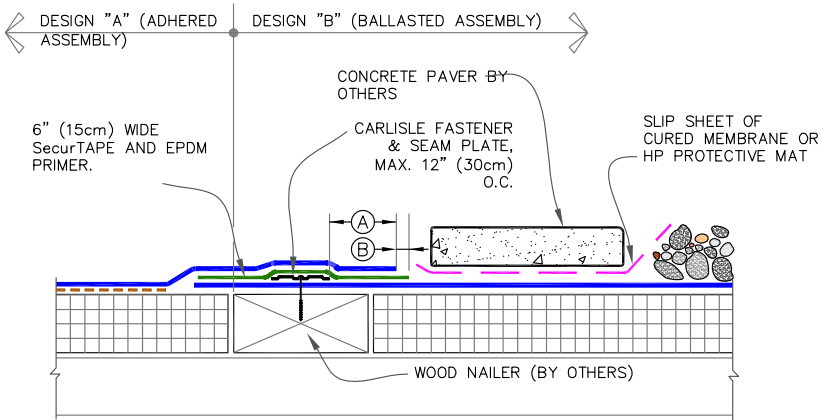

DIMENSIONS	cm	
(A) 2"	5	MIN.
(B) 1/8"	0.5	MIN.
1/2"	1.5	MAX.

	TIE-IN BETWEEN NEW CARLISLE ADHERED & BALLASTED ROOF		DETAIL NO.
	MAXIMUM WARRANTY: 30 YEARS		U-13F
		THERMOSET UNIVERSAL	

© 2023 Carlisle SynTec a division of Carlisle Construction Materials Incorporated

THERMOSET MEMBRANE

EPDM

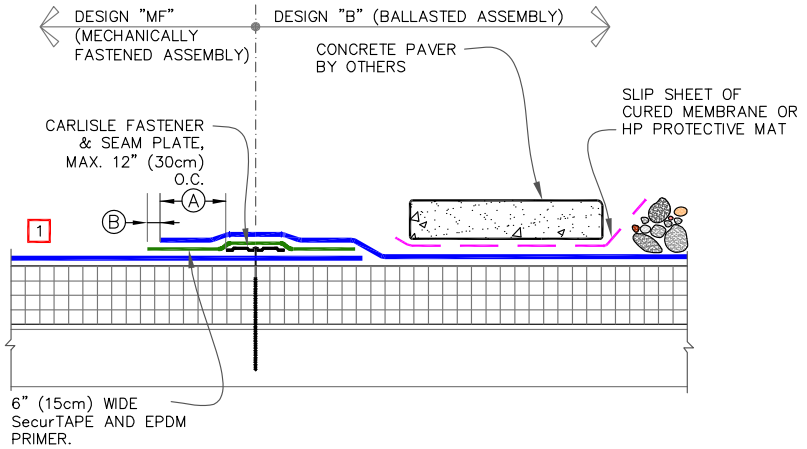

NOTE:

- ON MECHANICALLY FASTENED SYSTEMS, HP FASTENERS AND POLYMER SEAM PLATES ARE REQUIRED OVER STEEL DECKS.

DIMENSIONS	cm	
Ⓐ	2"	5 MIN.
Ⓑ	1/8"	0.5 MIN.
	1/2"	15 MAX.

	TIE-IN BETWEEN NEW CARLISLE MECHANICALLY FASTENED & BALLASTED ROOF		DETAIL NO.
	MAXIMUM WARRANTY: 30 YEARS		U-13G
		THERMOSET UNIVERSAL	

© 2023 Carlisle SynTec a division of Carlisle Construction Materials Incorporated

THERMOSET MEMBRANE

EPDM

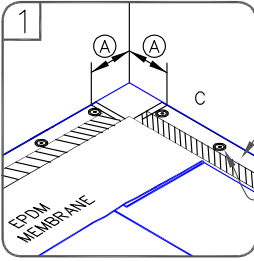

6" (15cm) WIDE PRESSURE-SENSITIVE RUSS (MAY BE FASTENED INTO VERTICAL SUBSTRATE)

CARLISLE SEAM PLATE & FASTENER.

EPDM PRIMER

CUT 45° AND APPLY EPDM PRIMER/SecurTAPE

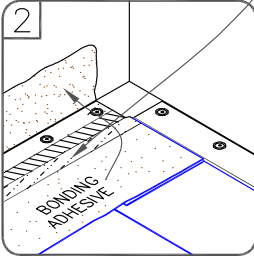
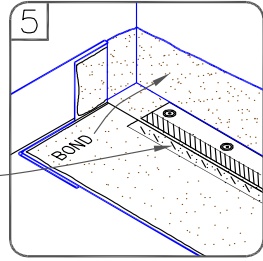

DIMENSIONS	cm	
(A) 6"	15	TO
9"	23	

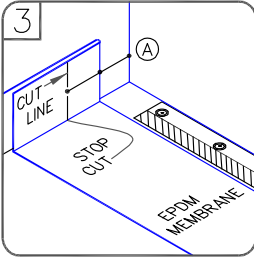
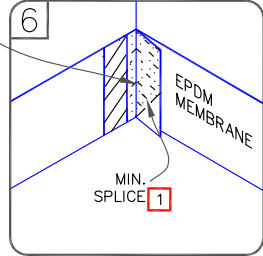

NOTE:

1. MINIMUM SPLICE WIDTH:
 - 1.1. 3" (7.5cm) UP TO 20 YEAR WARRANTIES
 - 1.2. 6" (15cm) FOR 25/30 YEAR WARRANTIES
2. REFER TO DETAIL [U-15C](#) (20 YEAR) OR [U-15D.1](#) (25/30 YEAR) FOR INSIDE CORNER INSTALLATION REQUIREMENTS.

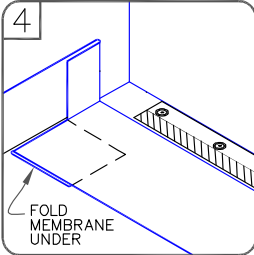
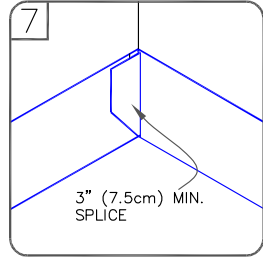

PIG EAR ON OPPOSITE WALL

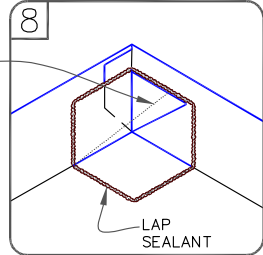

INSIDE CORNER WALL FLASHING WITH RUSS (OPTION 1)

MAXIMUM WARRANTY: 30 YEARS



DETAIL NO. U-15A

THERMOSET UNIVERSAL

THERMOSET MEMBRANE

EPDM

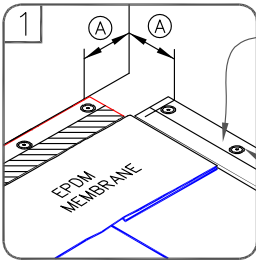

6" (15cm) WIDE PRESSURE-SENSITIVE RUS (MAY BE FASTENED INTO VERTICAL SUBSTRATE)
 FORM PIG EAR WITH CONTINUOUS MEMBRANE AT CORNER AS SHOWN
 CARLISLE SEAM PLATE & FASTENER.

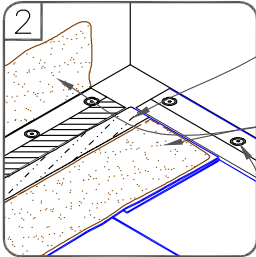
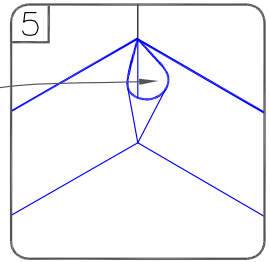

EPDM PRIMER
 CUT & REMOVE EXCESSIVE MEMBRANE
 SURE-SEAL BONDING ADHESIVE
 CARLISLE SEAM FASTENING PLATE & FASTENER.

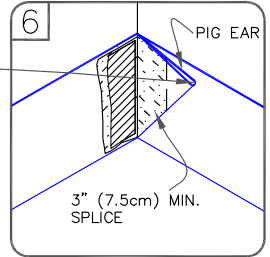

DIMENSIONS	cm	
(A) 6"	15	TO
9"	23	

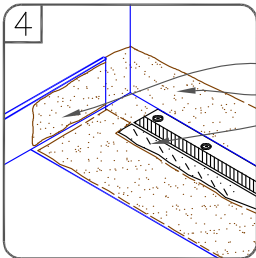
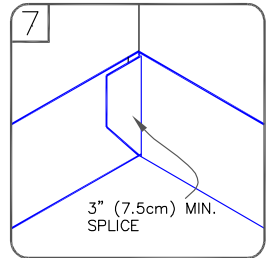
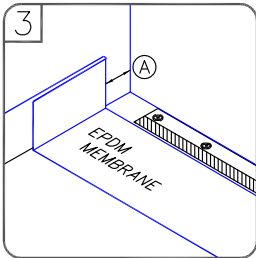

SURE-SEAL BONDING ADHESIVE
 EPDM PRIMER
 6" (15cm) WIDE PRESSURE-SENSITIVE ELASTOFORM FLASHING AND EPDM PRIMER

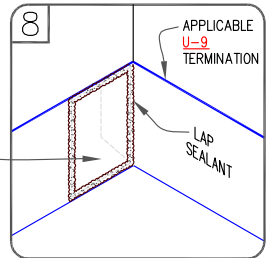

	INSIDE CORNER WALL FLASHING WITH RUS (OPTION 2)		DETAIL NO.
	MAXIMUM WARRANTY: 30 YEARS		U-15B
		THERMOSET UNIVERSAL	

THERMOSET MEMBRANE

EPDM

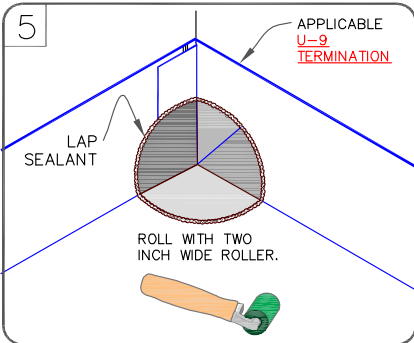
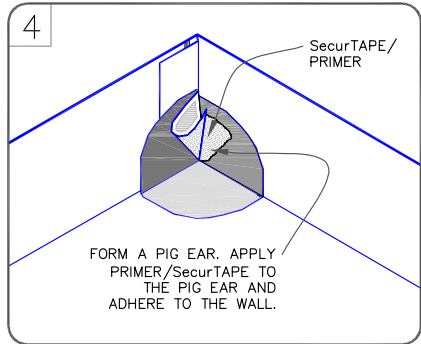
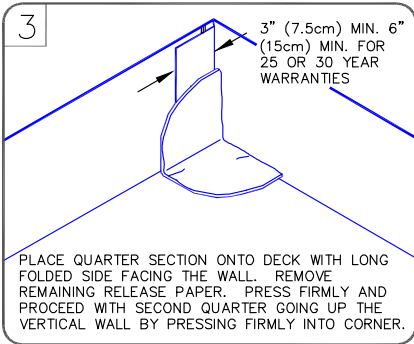
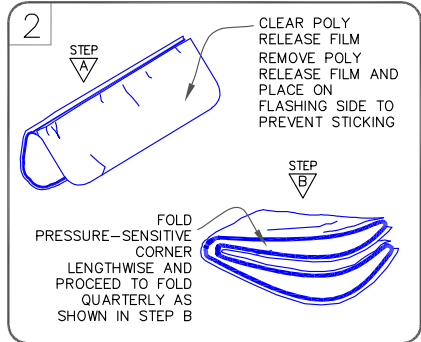
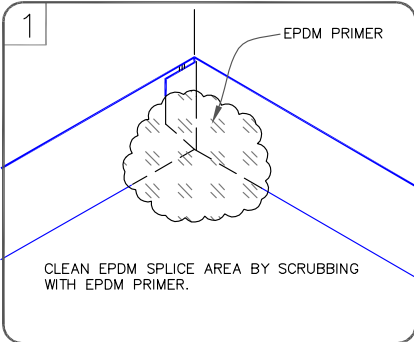

NOTES:

1. PRE-CUT 7" X 9" CORNER OR 9" X 9" PRESSURE SENSITIVE ELASTOFORM.
2. FOR PROJECTS WITH 25 AND 30-YEAR WARRANTIES OR WHEN USING 90-MIL MEMBRANE, INSTALL A 6" T-JOINT COVER PRIOR TO INSTALLING A 12" T-JOINT COVER. SEAL TOP LAYER WITH CONTINUOUS LAP SEALANT. PER DETAIL U-15D.1
3. A HEAT GUN MUST BE USED WHEN FORMING PRESSURE-SENSITIVE ELASTOFORM FLASHING IN COLDER TEMPERATURES.

	INSIDE CORNER WITH CONTINUOUS EPDM WALL FLASHING		DETAIL NO.
	MAXIMUM WARRANTY: 30 YEARS		U-15C
		THERMOSET UNIVERSAL	

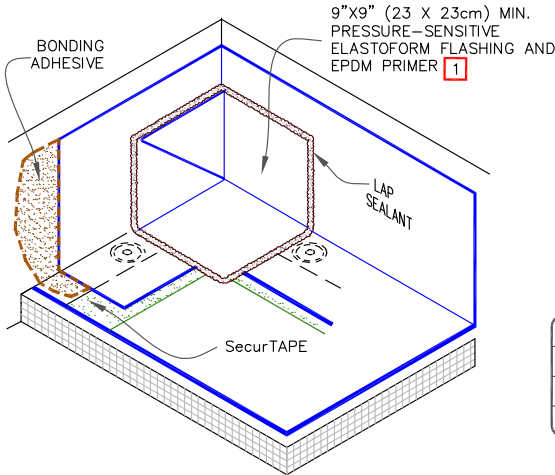
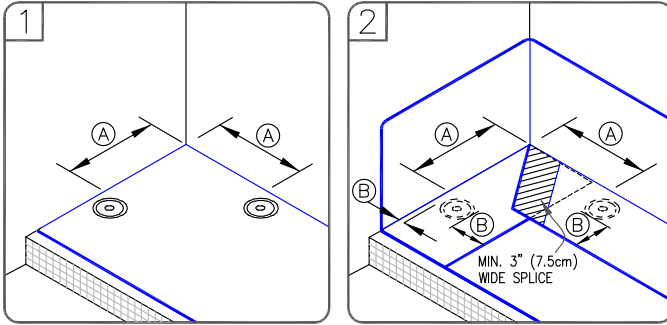

DIMENSIONS		cm	
(A)	6"	15	TO
	9"	23	
(B)	3"	7.5	

NOTES:

1. A HEAT GUN MUST BE USED WHEN FORMING PRESSURE-SENSITIVE ELASTOFORM FLASHING IN COLDER TEMPERATURES.
2. FOR PROJECTS WITH 25 & 30-YEAR WARRANTIES OR WHEN USING 90-MIL MEMBRANE, REFER TO [DETAIL U-15D.1](#) FOR REQUIRED FLASHING ENHANCEMENTS.

	INSIDE CORNER WITH SEPARATE EPDM WALL FLASHING		DETAIL NO.
	MAXIMUM WARRANTY: 20 YEARS		U-15D
		THERMOSET UNIVERSAL	

© 2023 Carlisle SynTec a division of Carlisle Construction Materials Incorporated

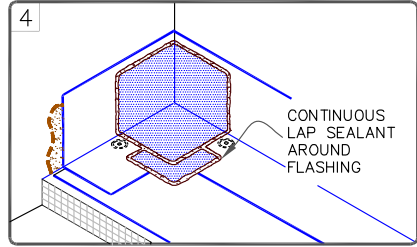
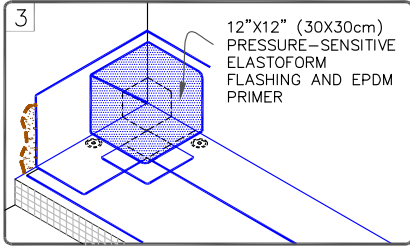
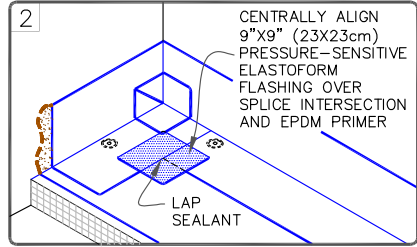
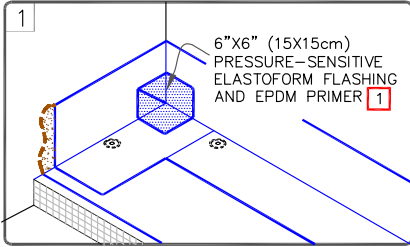

NOTES:

1. A 7"X9" (17.5cm X 23cm) PRESSURE-SENSITIVE PRE-CUT INSIDE/OUTSIDE CORNER MAY BE CUT DOWN TO 6" X 6" (7.5cm X 7.5cm).
2. A HEAT GUN MUST BE USED WHEN FORMING PRESSURE-SENSITIVE ELASTOFORM FLASHING IN COLDER TEMPERATURES.
3. APPLY PRIMER AND SecurTAPE TO ADHERE PIG EAR TO THE WALL.

	INSIDE CORNER FLASHING FOR PROJECTS WITH 90-MIL MEMBRANE OR 25 / 30 YEAR WARRANTIES		DETAIL NO.
	MAXIMUM WARRANTY: 30 YEARS		U-15D.1
		THERMOSET UNIVERSAL	

© 2023 Carlisle SynTec a division of Carlisle Construction Materials Incorporated

THERMOSET MEMBRANE

EPDM

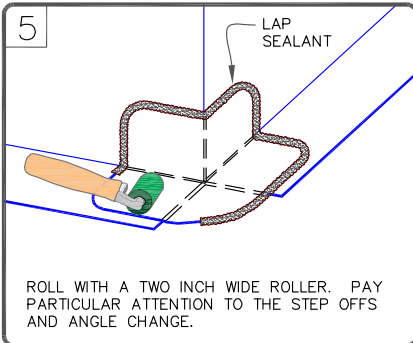
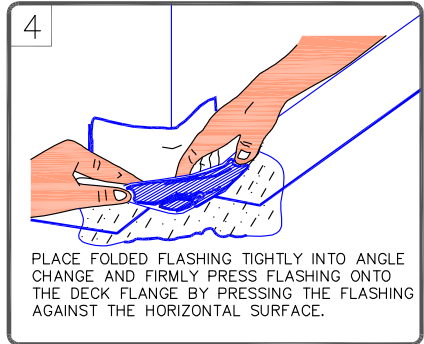
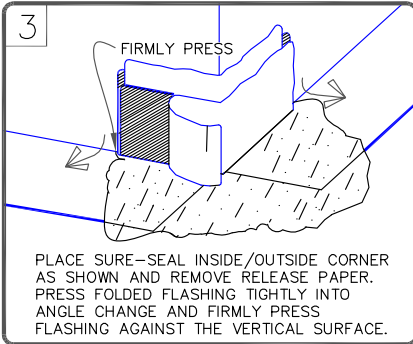
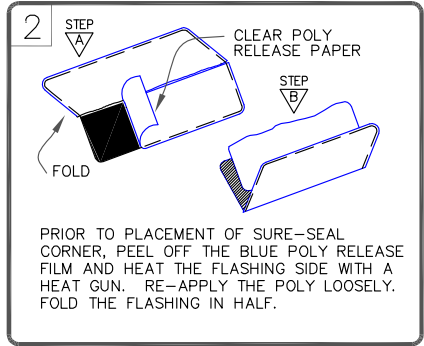
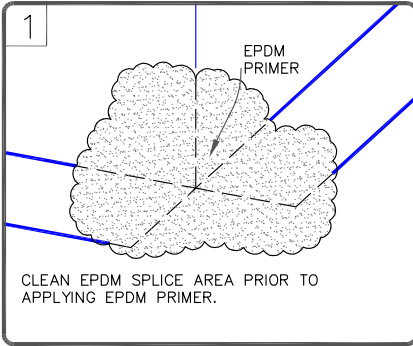

NOTE:

FOR PROJECTS WITH 25 & 30-YEAR WARRANTIES OR WHEN USING 90-MIL MEMBRANE, REFER TO [DETAIL U-15G.1](#) FOR REQUIRED FLASHING ENHANCEMENTS.

	OUTSIDE CORNER WITH PRE-CUT PRESSURE-SENSITIVE CORNER		DETAIL NO.
	MAXIMUM WARRANTY: 20 YEARS		U-15E THERMOSET UNIVERSAL

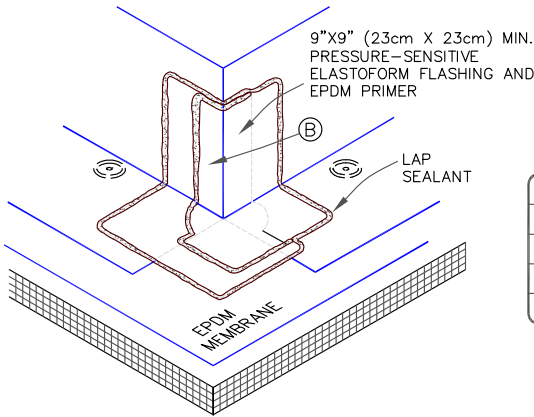
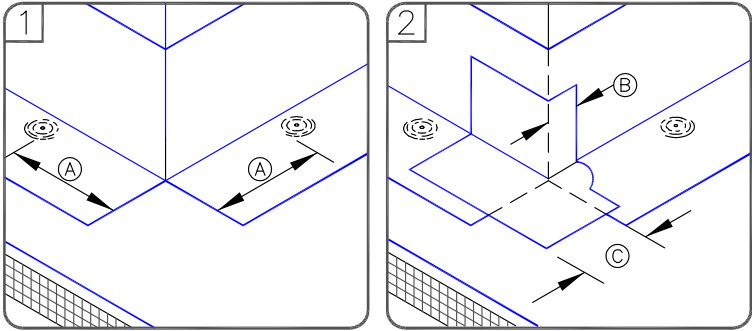

DIMENSIONS	cm	
(A)	6"	15 TO
	9"	23
(B)	2"	5 MIN.
(C)	3"	7.5 MAX.

NOTES:

1. A HEAT GUN MUST BE USED WHEN FORMING PRESSURE-SENSITIVE ELASTOFORM FLASHING IN COLDER TEMPERATURES.
2. FOR PROJECTS WITH 25 & 30-YEAR WARRANTIES OR WHEN USING 90-MIL MEMBRANE, REFER TO [DETAIL U-15G.1](#) FOR REQUIRED FLASHING ENHANCEMENTS.



OUTSIDE CORNER WITH
PRESSURE-SENSITIVE ELASTOFORM
FLASHING (2 PIECE)

MAXIMUM WARRANTY: 20 YEARS



DETAIL NO.
U-15F

THERMOSET UNIVERSAL

THERMOSET MEMBRANE

EPDM

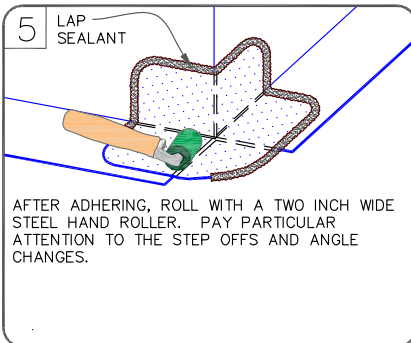
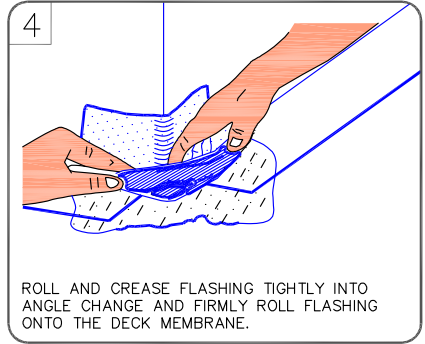
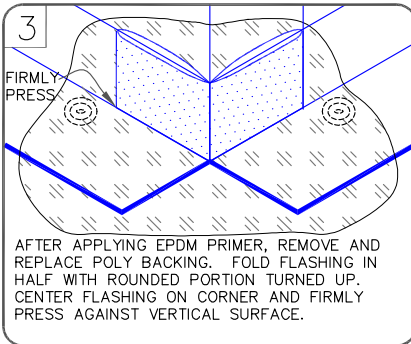
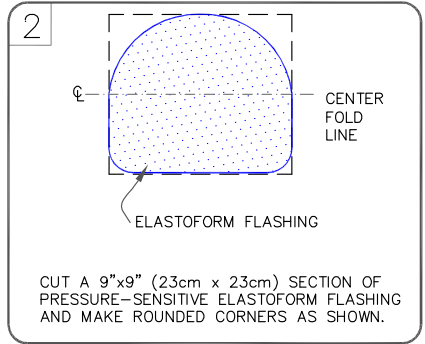
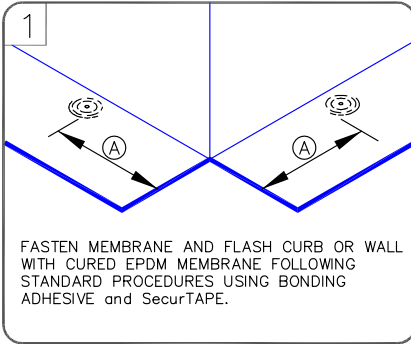

DIMENSIONS	cm	
(A) 6"	15	TO
9"	23	

NOTES:

- FOR PROJECTS WITH 25 & 30-YEAR WARRANTIES OR WHEN USING 90-MIL MEMBRANE, REFER TO [DETAIL U-15G.1](#) FOR REQUIRED FLASHING ENHANCEMENTS.
- A HEAT GUN MUST BE USED WHEN FORMING PRESSURE-SENSITIVE ELASTOFORM FLASHING IN COLDER TEMPERATURES.

	OUTSIDE CORNER WITH PRESSURE-SENSITIVE ELASTOFORM FLASHING (1 PIECE)		DETAIL NO.
	MAXIMUM WARRANTY: 20 YEARS		U-15G
		THERMOSET UNIVERSAL	

THERMOSET MEMBRANE

EPDM

1

FASTEN MEMBRANE AND FLASH CURB OR WALL WITH CURED EPDM MEMBRANE FOLLOWING STANDARD PROCEDURES.

2

CENTER FOLD LINE

USE PRE-CUT T-JOINT COVERS OR CUT A 6"x6" (15X15cm) & 12"x12" (30X30cm) SECTION OF PRESSURE- SENSITIVE ELASTOFORM FLASHING AND ROUND CORNERS

3

EPDM PRIMER

CLEAN EPDM SPLICE AREA WITH WEATHERED MEMBRANE CLEANER PRIOR TO APPLYING EPDM PRIMER

4

POLY FILM

REMOVE & REPLACE POLY BACKING ON FLASHING. FOLD FLASHING IN HALF WITH ROUNDED PORTION TURNED UP. CENTER ON CORNER & FIRMLY PRESS AGAINST VERTICAL SURFACE

5

ROLL & CREASE FLASHING TIGHTLY INTO ANGLE CHANGE & FIRMLY ROLL FLASHING ONTO THE DECK MEMBRANE

USE HEAT GUN TO WARM THE FLASHING IN COLD WEATHER

6

ROLL WITH A TWO INCH WIDE STEEL HAND ROLLER. PAY PARTICULAR ATTENTION TO THE STEP OFFS AND ANGLE CHANGES

7

ROLL STEP OFFS AND ANGLE CHANGES

8

APPLY EPDM PRIMER TO SPLICE AREA. INSTALL THE 12"x12" (30cmX30cm) SECTION OF PRESSURE- SENSITIVE ELASTOFORM FLASHING CENTERED OVER PREVIOUSLY APPLIED FLASHING.

9

SEAL ALL EDGES WITH LAP SEALANT AS SHOWN

	OUTSIDE CORNER FLASHING FOR PROJECTS WITH 90-MIL MEMBRANE OR 25 / 30 YEAR WARRANTIES		DETAIL NO.
	MAXIMUM WARRANTY: 30 YEARS		U-15G.1
		THERMOSET UNIVERSAL	

■■■■ THERMOSET MEMBRANE ■■■■ EPDM ■■■■

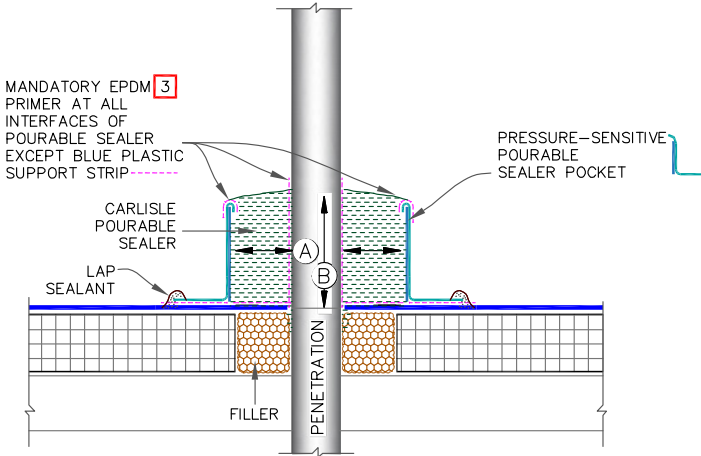

NOTES:

1. THE MAXIMUM ALLOWABLE SURFACE TEMPERATURE OF THE PENETRATION SHALL NOT EXCEED 180° F (82° C).
2. ALL DEBRIS (PAINT, RUST, LEAD, OTHER FLASHINGS, ETC.) MUST BE REMOVED FROM THE PENETRATION.
3. ALL SURFACES MUST BE PRIMED WITH EPDM PRIMER PRIOR TO APPLYING POURABLE SEALER. DO NOT PRIME THE BLUE PLASTIC SUPPORT STRIP.
4. POURABLE SEALER MUST COMPLETELY FILL POURABLE SEALER POCKET TO PREVENT PONDING OF WATER.
5. POURABLE SEALER MUST CONTACT PRIMED PRESSURE-SENSITIVE ELASTOFORM FLASHING AND DECK MEMBRANE.
6. SECUREMENT IS REQUIRED FOR POURABLE SEALER POCKETS WHICH ARE GREATER THAN 18" (46cm) IN DIAMETER. REFER TO SPECIFICATIONS.
7. ON MECHANICALLY-FASTENED ROOFING SYSTEMS, ADDITIONAL MEMBRANE SECUREMENT IS REQUIRED (SIMILAR TO [DETAIL MF-8A](#)) REGARDLESS OF SIZE OR DIAMETER.
8. MINIMUM 1" (2.5cm) CLEARANCE REQUIRED BETWEEN PENETRATIONS.

DIMENSIONS	cm	
(A)	1"	2.5 MIN.
(B)	2"	5 MIN.

	PRESSURE-SENSITIVE POURABLE SEALER POCKET		DETAIL NO.
	MAXIMUM WARRANTY: 20 YEARS		U-16A
		THERMOSET UNIVERSAL	

© 2023 Carlisle SynTec a division of Carlisle Construction Materials Incorporated

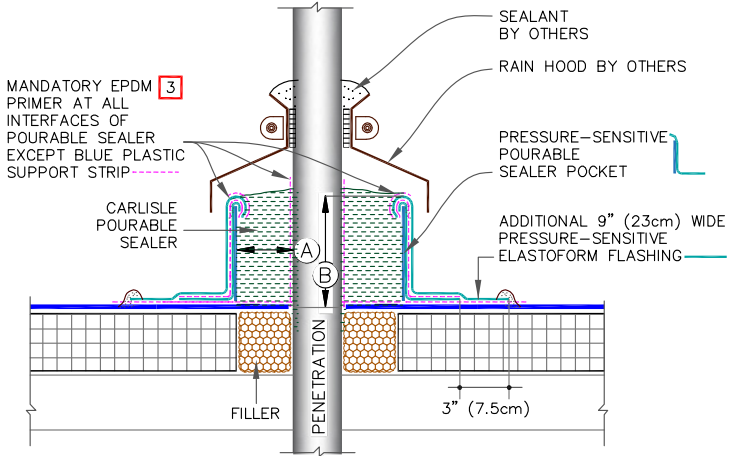

NOTES:

1. THE MAXIMUM ALLOWABLE SURFACE TEMPERATURE OF THE PENETRATION SHALL NOT EXCEED 180° F (82° C).
2. ALL DEBRIS (PAINT, RUST, LEAD, OTHER FLASHINGS, ETC.) MUST BE REMOVED FROM THE PENETRATION.
3. ALL SURFACES MUST BE PRIMED WITH EPDM PRIMER PRIOR TO APPLYING POURABLE SEALER. DO NOT PRIME THE BLUE PLASTIC SUPPORT STRIP.
4. POURABLE SEALER MUST COMPLETELY FILL POURABLE SEALER POCKET TO PREVENT PONDING OF WATER.
5. POURABLE SEALER MUST CONTACT PRIMED PRESSURE-SENSITIVE ELASTOFORM FLASHING AND DECK MEMBRANE.
6. SECUREMENT IS REQUIRED FOR POURABLE SEALER POCKETS WHICH ARE GREATER THAN 18" (46cm) IN DIAMETER. REFER TO SPECIFICATIONS.
7. ON MECHANICALLY-FASTENED ROOFING SYSTEMS, ADDITIONAL MEMBRANE SECUREMENT IS REQUIRED (SIMILAR TO **DETAIL MF-8A**) REGARDLESS OF SIZE OR DIAMETER.
8. MINIMUM 1" (2.5cm) CLEARANCE REQUIRED BETWEEN PENETRATIONS.

DIMENSIONS	cm	
(A)	1"	2.5 MIN.
(B)	2"	5 MIN.

	PRESSURE-SENSITIVE POURABLE SEALER POCKET (25/30 YEAR WARRANTIES)		DETAIL NO.
	MAXIMUM WARRANTY: 30 YEARS		U-16A.1
		THERMOSET UNIVERSAL	

© 2023 Carlisle SynTec a division of Carlisle Construction Materials Incorporated

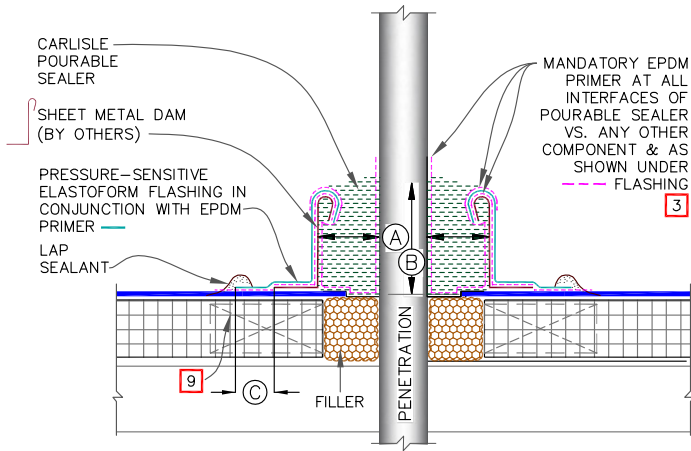

NOTES:

1. THE MAXIMUM ALLOWABLE SURFACE TEMPERATURE OF THE PENETRATION SHALL NOT EXCEED 180° F (82° C).
2. ALL DEBRIS (PAINT, RUST, LEAD, OTHER FLASHINGS, ETC.) MUST BE REMOVED FROM THE PENETRATION.
3. ALL SURFACES MUST BE PRIMED WITH EPDM PRIMER PRIOR TO APPLYING POURABLE SEALER.
4. POURABLE SEALER MUST COMPLETELY FILL POURABLE SEALER POCKET TO PREVENT PONDING OF WATER.
5. POURABLE SEALER MUST CONTACT PRIMED PRESSURE-SENSITIVE ELASTOFORM FLASHING AND DECK MEMBRANE.
6. SECUREMENT IS REQUIRED FOR POURABLE SEALER POCKETS WHICH ARE GREATER THAN 18" (46cm) IN DIAMETER. REFER TO SPECIFICATIONS.
7. ON MECHANICALLY-FASTENED ROOFING SYSTEMS, ADDITIONAL MEMBRANE SECUREMENT IS REQUIRED (SIMILAR TO [DETAIL MF-8A](#)) REGARDLESS OF SIZE AND DIAMETER, UNLESS WOOD NAILERS ARE PRESENT.
8. DECK FLANGE MUST BE CONTINUOUS WITH ROUNDED CORNERS.
9. WHEN ANY ONE SIDE OF THE FIELD FABRICATED POURABLE SEALER POCKET EXCEEDS 12" (30cm), USE WOOD BLOCKING TO ANCHOR SHEET METAL.
10. MINIMUM 1" (2.5cm) CLEARANCE REQUIRED BETWEEN PENETRATIONS.

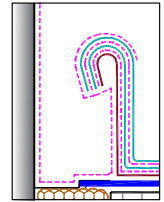

MANDATORY EPDM PRIMER AT ALL INTERFACES OF POURABLE SEALER VS. ANY OTHER COMPONENT & AS SHOWN UNDER FLASHING

DIMENSIONS	cm	
(A)	1"	2.5 MIN.
(B)	2"	5 MIN.
(C)	3"	7.5



FIELD FABRICATED POURABLE SEALER POCKET

MAXIMUM WARRANTY: 20 YEARS



DETAIL NO.

U-16B

THERMOSET UNIVERSAL

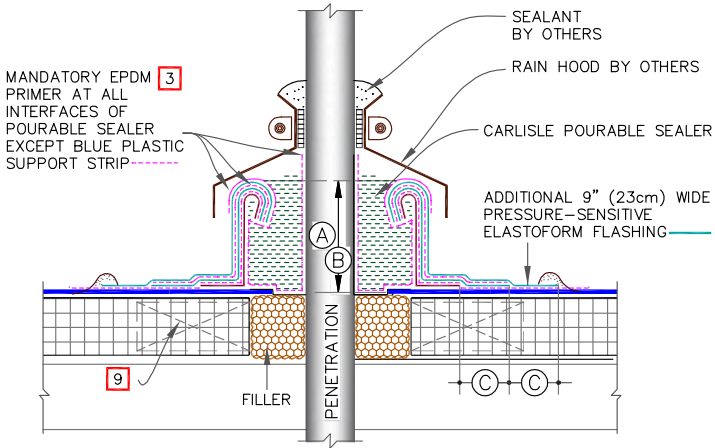

NOTES:

1. THE MAXIMUM ALLOWABLE SURFACE TEMPERATURE OF THE PENETRATION SHALL NOT EXCEED 180° F (82° C).
2. ALL DEBRIS (PAINT, RUST, LEAD, OTHER FLASHINGS, ETC.) MUST BE REMOVED FROM THE PENETRATION.
3. ALL SURFACES MUST BE PRIMED WITH EPDM PRIMER PRIOR TO APPLYING POURABLE SEALER.
4. POURABLE SEALER MUST COMPLETELY FILL POURABLE SEALER POCKET TO PREVENT PONDING OF WATER.
5. POURABLE SEALER MUST CONTACT PRIMED PRESSURE-SENSITIVE ELASTOFORM FLASHING AND DECK MEMBRANE.
6. SECUREMENT IS REQUIRED FOR POURABLE SEALER POCKETS WHICH ARE GREATER THAN 18" (46cm) IN DIAMETER. REFER TO SPECIFICATIONS.
7. ON MECHANICALLY-FASTENED ROOFING SYSTEMS, ADDITIONAL MEMBRANE SECUREMENT IS REQUIRED (SIMILAR TO [DETAIL_MF-8A](#)) REGARDLESS OF SIZE AND DIAMETER, UNLESS WOOD NAILERS ARE PRESENT.
8. DECK FLANGE MUST BE CONTINUOUS WITH ROUNDED CORNERS.
9. WHEN ANY ONE SIDE OF THE FIELD FABRICATED POURABLE SEALER POCKET EXCEEDS 12" (30cm), USE WOOD BLOCKING TO ANCHOR SHEET METAL.
10. MINIMUM 1" (2.5cm) CLEARANCE REQUIRED BETWEEN PENETRATIONS.

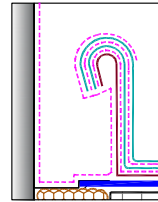

MANDATORY EPDM PRIMER AT ALL INTERFACES OF POURABLE SEALER VS. ANY OTHER COMPONENT & AS SHOWN UNDER --- FLASHING

DIMENSIONS	cm	
(A)	1"	2.5 MIN.
(B)	2"	5 MIN.
(C)	3"	7.5

	FIELD FABRICATED POURABLE SEALER POCKET (25/30 YEAR WARRANTIES)		DETAIL NO.
	MAXIMUM WARRANTY: 30 YEARS		U-16B.1
		THERMOSET UNIVERSAL	

© 2023 Carlisle SynTec a division of Carlisle Construction Materials Incorporated

THERMOSET MEMBRANE

EPDM

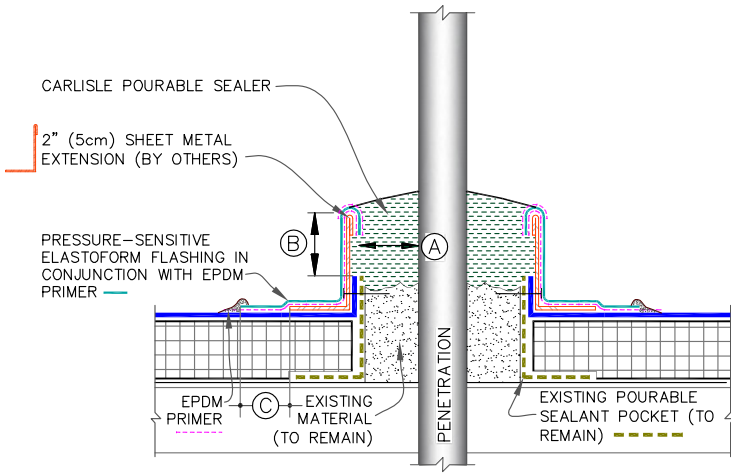

NOTES:

1. THE MAXIMUM ALLOWABLE SURFACE TEMPERATURE OF THE PENETRATION SHALL NOT EXCEED 180° F (82° C).
2. ALL DEBRIS (PAINT, RUST, LEAD, OTHER FLASHINGS, ETC.) MUST BE REMOVED FROM THE PENETRATION.
3. ALL SURFACES MUST BE PRIMED WITH EPDM PRIMER PRIOR TO APPLYING POURABLE SEALER.
4. POURABLE SEALER MUST COMPLETELY FILL POURABLE SEALER POCKET TO PREVENT PONDING OF WATER.
5. POURABLE SEALER MUST CONTACT PRIMED PRESSURE-SENSITIVE ELASTOFORM FLASHING.
6. SHAPE METAL DAM TO FIT EXISTING PITCH POCKET.
7. SECUREMENT IS REQUIRED FOR POURABLE SEALER POCKETS WHICH ARE GREATER THAN 18" (46cm) IN DIAMETER. REFER TO SPECIFICATIONS.
8. ON MECHANICALLY-FASTENED ROOFING SYSTEMS, ADDITIONAL MEMBRANE SECUREMENT IS REQUIRED (SIMILAR TO [DETAIL MF-8A](#)) REGARDLESS OF SIZE OR DIAMETER.
9. MINIMUM 1" (2.5cm) CLEARANCE REQUIRED BETWEEN PENETRATIONS.

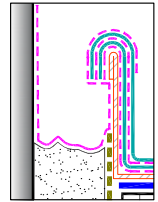

MANDATORY EPDM PRIMER AT ALL INTERFACES OF POURABLE SEALER

DIMENSIONS	cm	
(A)	1"	2.5 MIN.
(B)	2"	5 MIN.
(C)	3"	7.5

	EXTENDED POURABLE SEALER POCKET		DETAIL NO.
	MAXIMUM WARRANTY: 20 YEARS		U-16C
		THERMOSET UNIVERSAL	

© 2023 Carlisle SynTec a division of Carlisle Construction Materials Incorporated

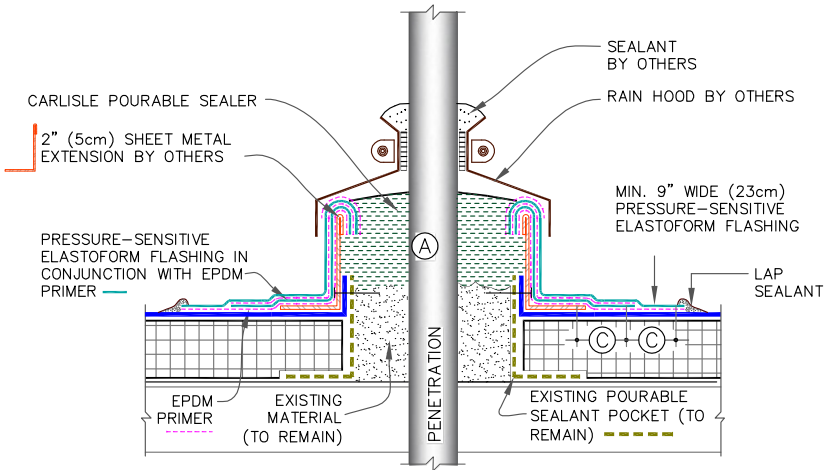

NOTES:

1. THE MAXIMUM ALLOWABLE SURFACE TEMPERATURE OF THE PENETRATION SHALL NOT EXCEED 180° F (82° C).
2. ALL DEBRIS (PAINT, RUST, LEAD, OTHER FLASHINGS, ETC.) MUST BE REMOVED FROM THE PENETRATION.
3. ALL SURFACES MUST BE PRIMED WITH EPDM PRIMER PRIOR TO APPLYING POURABLE SEALER.
4. POURABLE SEALER MUST COMPLETELY FILL POURABLE SEALER POCKET TO PREVENT PONDING OF WATER.
5. POURABLE SEALER MUST CONTACT PRIMED PRESSURE-SENSITIVE ELASTOFORM FLASHING.
6. SHAPE METAL DAM TO FIT EXISTING PITCH POCKET.
7. SECUREMENT IS REQUIRED FOR POURABLE SEALER POCKETS WHICH ARE GREATER THAN 18" (46cm) IN DIAMETER. REFER TO SPECIFICATIONS.
8. ON MECHANICALLY-FASTENED ROOFING SYSTEMS, ADDITIONAL MEMBRANE SECUREMENT IS REQUIRED (SIMILAR TO [DETAIL MF-8A](#)) REGARDLESS OF SIZE OR DIAMETER.
9. MINIMUM 1" (2.5cm) CLEARANCE REQUIRED BETWEEN PENETRATIONS.

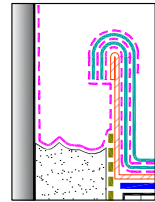

MANDATORY EPDM PRIMER AT ALL INTERFACES OF POURABLE SEALER

DIMENSIONS	cm	
(A)	1"	2.5 MIN.
(B)	2"	5 MIN.
(C)	3"	7.5

	EXTENDED POURABLE SEALER POCKET (25/30 YEAR WARRANTIES)		DETAIL NO.
	MAXIMUM WARRANTY: 30 YEARS		U-16C.1
		THERMOSET UNIVERSAL	

© 2023 Carlisle SynTec a division of Carlisle Construction Materials Incorporated

THERMOSET MEMBRANE

EPDM

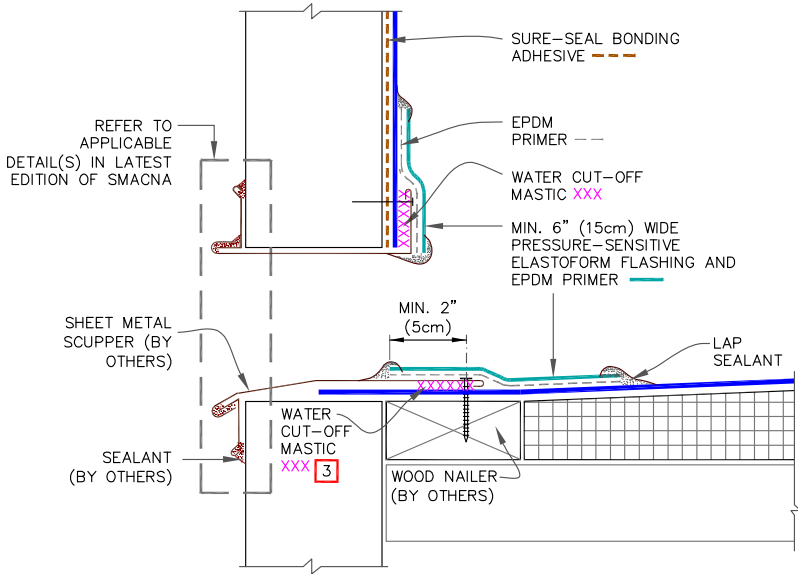

NOTES:

1. METAL SCUPPER BOX MUST HAVE CONTINUOUS FLANGES WITH ROUNDED CORNERS. SOLDER ALL SCUPPER SEAMS WATER-TIGHT.
2. INSTALL U-15 CORNERS IF SCUPPER BOX DOES NOT HAVE A CONTINUOUS FLANGE.
3. WATER CUT-OFF MASTIC UNDER SCUPPER FLANGES MUST BE UNDER CONSTANT COMPRESSION.
4. CLEAN METAL FLANGE WITH WEATHERED MEMBRANE CLEANER; AND ALLOW TO DRY.
5. SCUPPERS WITHOUT A CONTINUOUS WATERTIGHT DESIGN MUST BE FLASHED IN PER DETAIL U-15 OUTSIDE CORNER.

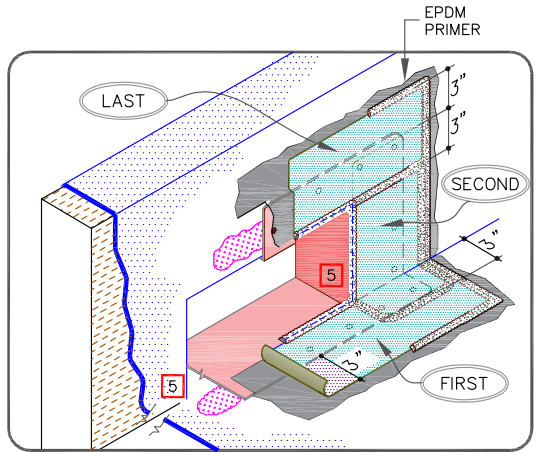

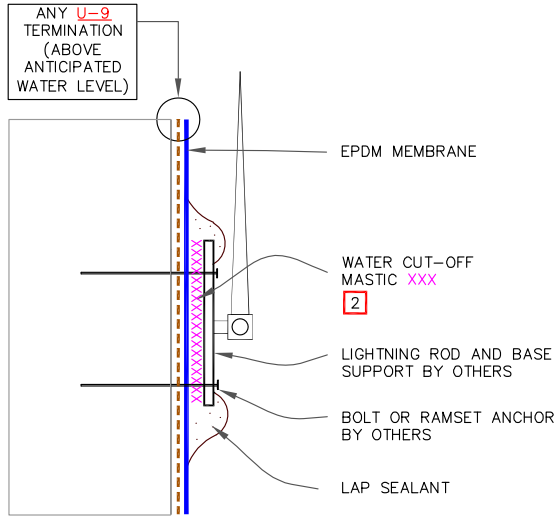

	METAL SCUPPER WITH CONTINUOUS FLANGE AT DECK		DETAIL NO.
	MAXIMUM WARRANTY: 30 YEARS		U-18A
		THERMOSET UNIVERSAL	

© 2023 Carlisle SynTec a division of Carlisle Construction Materials Incorporated



NOTES:

1. DETAIL MAY BE USED FOR ANY FASTENER PENETRATION (E.G., ACCESS LADDER, ANCHOR SUPPORT TO PARAPET).
2. WATER CUT-OFF MASTIC MUST BE UNDER CONSTANT COMPRESSION.
3. COMPLY WITH ZONING ORDINANCE AND LOCAL CODES FOR MOUNTING A LIGHTNING SYSTEM.
4. DETAIL UNACCEPTABLE FOR HORIZONTAL APPLICATIONS ON ROOF DECK.

	LIGHTNING ROD AT PARAPET (VERTICAL ATTACHMENT)		DETAIL NO.
	MAXIMUM WARRANTY: 30 YEARS		U-20A
		THERMOSET UNIVERSAL	

© 2023 Carlisle SynTec a division of Carlisle Construction Materials Incorporated

■■■■ THERMOSET MEMBRANE ■■■■ EPDM ■■■■

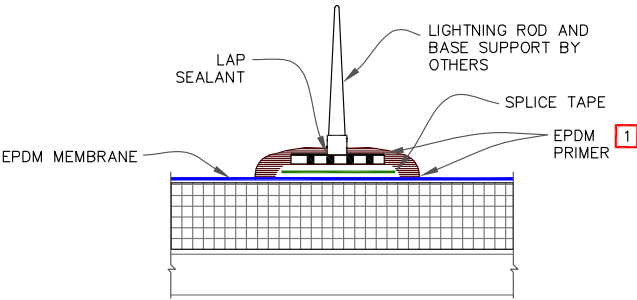
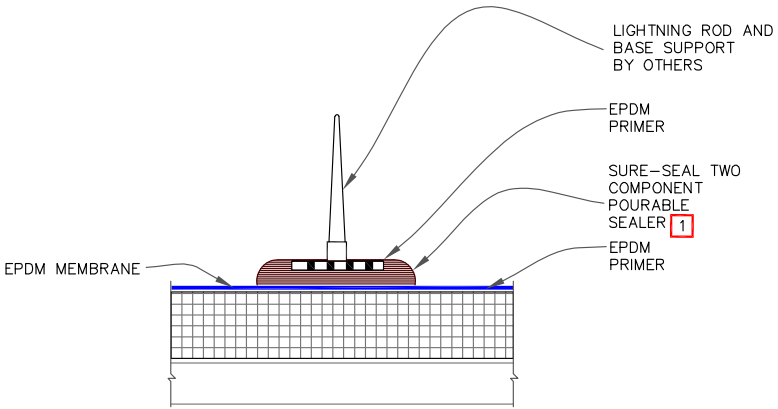

NOTES:

1. SURE-SEAL TWO COMPONENT POURABLE SEALER IN CONJUNCTION WITH EPDM PRIMER, OR UNIVERSAL SINGLE-PLY SEALANT.
2. CLEAN EXPOSED MEMBRANE WITH WEATHERED MEMBRANE CLEANER AND ALLOW TO DRY.
3. PRIOR TO THE APPLICATION OF POURABLE SEALER, APPLY EPDM PRIMER TO THE MEMBRANE AND LIGHTNING ROD BASE ACHIEVING A VERY THIN EVEN COAT ON BOTH SURFACES. ALLOW PRIMER TO DRY UNTIL IT IS TACK FREE.
4. COMPLY WITH ZONING ORDANCE AND LOCAL CODES FOR MOUNTING A LIGHTNING SYSTEM.

	LIGHTNING ROD AT DECK LEVEL		DETAIL NO.
	MAXIMUM WARRANTY: 30 YEARS		U-20B
		THERMOSET UNIVERSAL	

© 2023 Carlisle SynTec a division of Carlisle Construction Materials Incorporated

THERMOSET MEMBRANE EPDM

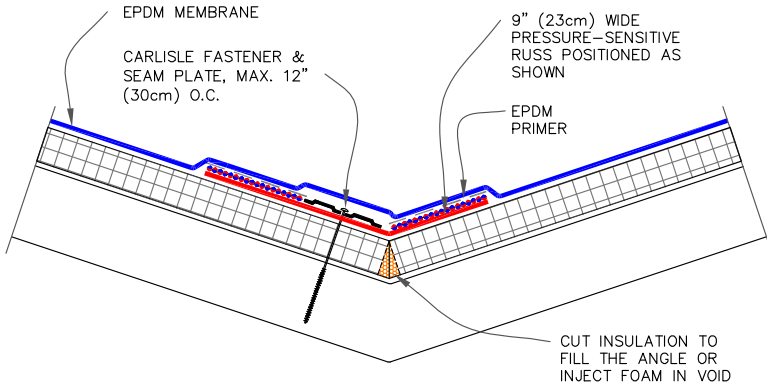

NOTES:

1. DETAIL FOR SURE-SEAL/SURE-WHITE ADHERED AND SURE-TOUGH MECHANICALLY-FASTENED ROOFING SYSTEMS WHEN SLOPE AT VALLEY EXCEEDS 2" (5cm) IN ONE HORIZONTAL FOOT.
2. ON MECHANICALLY-FASTENED ROOFING SYSTEMS, HP FASTENERS AND POLYMER SEAMS ARE REQUIRED OVER STEEL DECKS.
3. EPDM PRIMER MUST BE APPLIED TO BACK SIDE OF DECK MEMBRANE PRIOR TO COMPLETING SPLICE TO PRESSURE-SENSITIVE RUSS.

	VALLEY		DETAIL NO.
	MAXIMUM WARRANTY: 30 YEARS		U-22
		THERMOSET UNIVERSAL	

© 2023 Carlisle SynTec a division of Carlisle Construction Materials Incorporated

■■■■ THERMOSET MEMBRANE ■■■■

■■■■ EPDM ■■■■

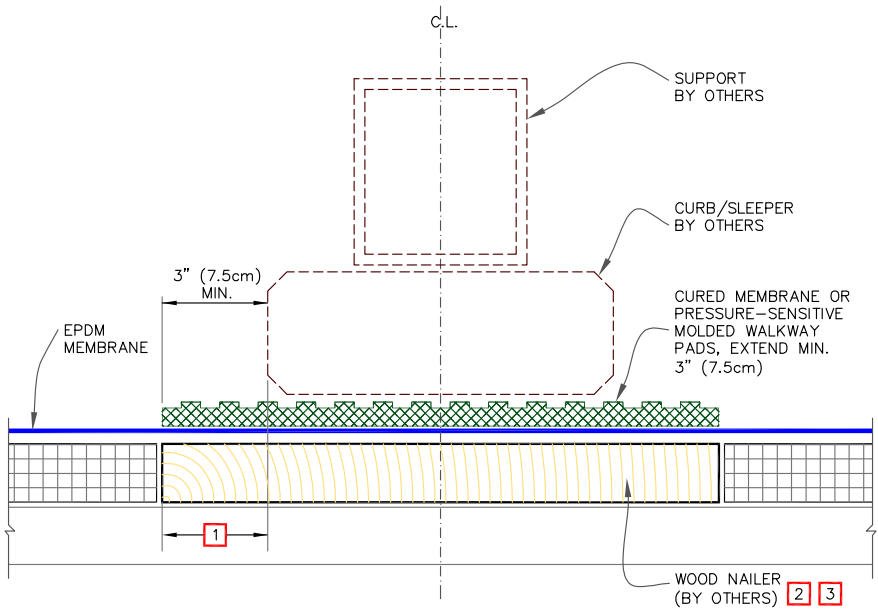

NOTES:

1. SLEEPER MUST BE LARGE ENOUGH TO SUPPORT WEIGHT OF EQUIPMENT WITHOUT INDENTING INSULATION. EXTEND WOOD NAILER OUT AS REQUIRED BY STRUCTURAL ENGINEER TO DISTRIBUTE SUBJECT LOAD OR AT LEAST EXTEND OUT MIN. 3" (7.5cm).
2. ENSURE SCREW/ANCHOR HEADS IN TOP SURFACE OF WOOD BLOCKING ARE RECESSED TO PROTECT MEMBRANE.
3. WOOD NAILERS REQUIRED IF WEIGHT OF SLEEPER MAY INDENT OR DAMAGE INSULATION.
4. CONSULT STRUCTURAL ENGINEER AND/OR SPECIFIER TO AVOID WATER PONDING DUE TO DECK DEFLECTION.

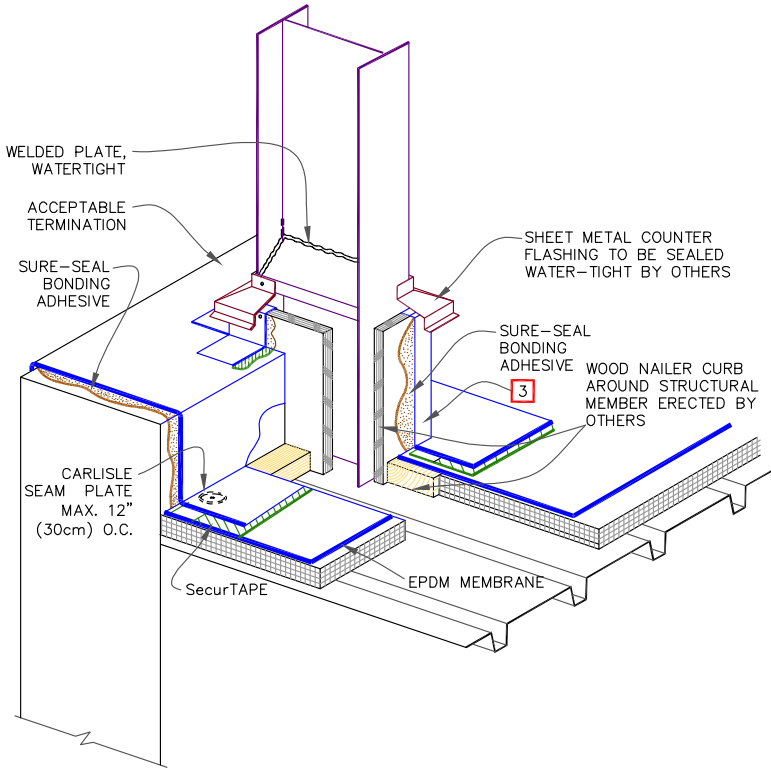

	SLEEPER		DETAIL NO.
	MAXIMUM WARRANTY: 30 YEARS		U-24
		THERMOSET UNIVERSAL	

© 2023 Carlisle SynTec a division of Carlisle Construction Materials Incorporated



NOTES:

1. FOR PARAPET FLASHING, REFER TO DETAIL(S) [U-12](#).
2. FOR CURB FLASHING, REFER TO DETAIL(S) [U-5](#).
3. FOR CORNER APPLICATION, REFER TO DETAIL(S) [U-15](#).

	I-BEAM PENETRATION		DETAIL NO.
	MAXIMUM WARRANTY: 30 YEARS		U-30
		THERMOSET UNIVERSAL	

© 2023 Carlisle SynTec a division of Carlisle Construction Materials Incorporated

THERMOSET MEMBRANE

SAT EPDM

SIDE LAP SPLICE

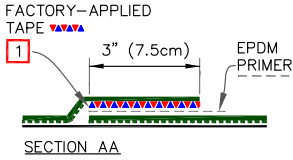

END LAP SPLICE

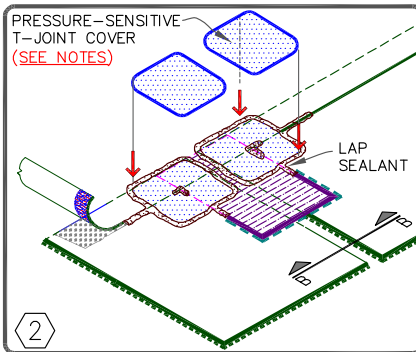
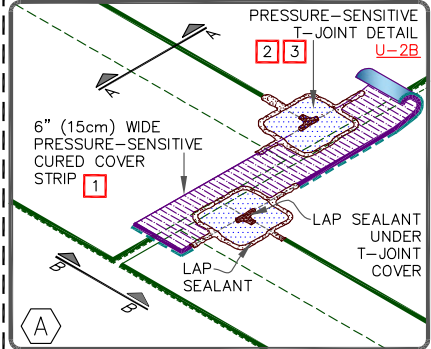
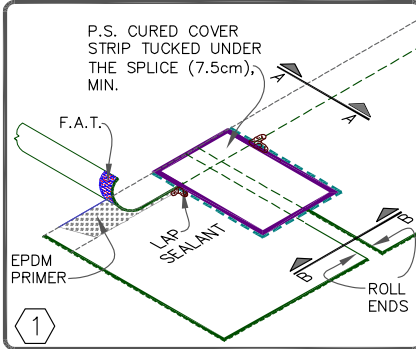
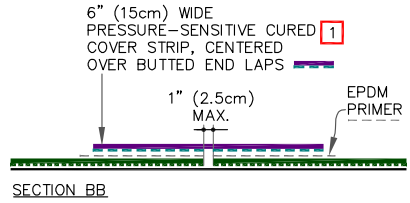

NOTES:

1. PRESSURE-SENSITIVE OVERLAYMENT STRIP CAN BE USED WHEN SAT IS OVERLAPPED A MINIMUM 1" (2.5cm) ELIMINATING THE NEED FOR T-JOINT COVERS.
2. APPLY LAP SEALANT ALONG THE EDGE OF THE MEMBRANE SPLICE UNDER THE 6" (15cm) T-JOINT COVER COVERING THE EXPOSED SPLICE TAPE 1/2" (1.5cm) IN EACH DIRECTION FROM THE SPLICE INTERSECTION.
3. APPLY A 6" (15cm) T-JOINT COVER OR PRESSURE-SENSITIVE ELASTOFORM FLASHING AND LAP SEAL THE EDGES.

SAT EPDM MEMBRANE SPLICES		 DETAIL NO. SAT-2A SELF ADHERING TECHNOLOGY
MAXIMUM WARRANTY: 20 YEARS		

© 2023 Carlisle SynTec a division of Carlisle Construction Materials Incorporated

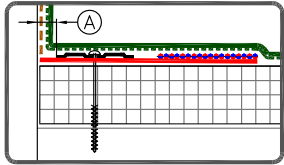
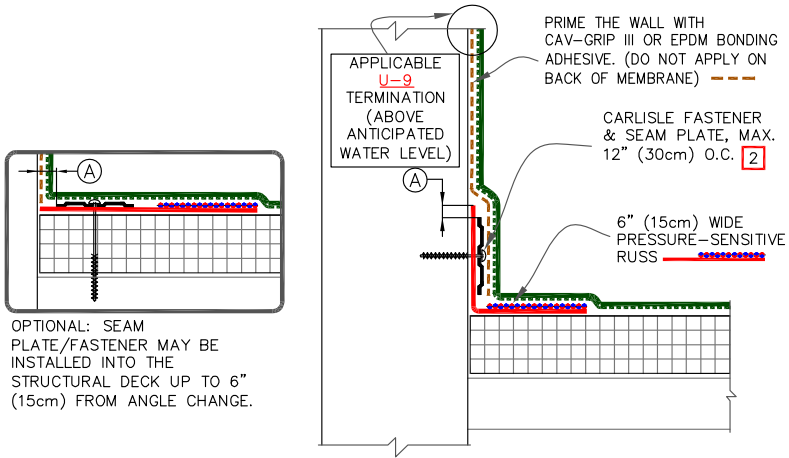

OPTIONAL: SEAM PLATE/FASTENER MAY BE INSTALLED INTO THE STRUCTURAL DECK UP TO 6" (15cm) FROM ANGLE CHANGE.

DIMENSION		cm
(A)	1/8" - 1"	0.5 - 2.5

NOTES:

1. FOR CORNERS AND RUSS APPLICATION, REFER TO DETAILS [U-15A](#) OR [U-15B](#).
2. FASTENERS AND PLATES REQUIRED AT 6" (7.5cm) O.C. FOR WARRANTY WIND SPEEDS EXCEEDING 90 MPH.

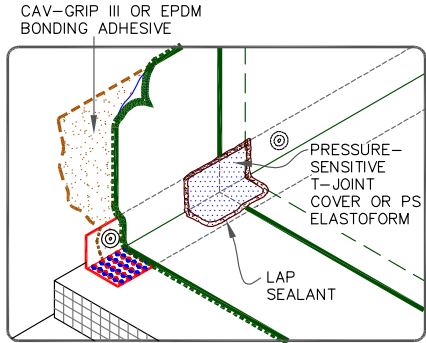

	PARAPET / CURB WITH CONTINUOUS MEMBRANE - RUSS	DETAIL NO.
	MAXIMUM WARRANTY: 20 YEARS	SAT-12A
		SELF ADHERING TECHNOLOGY

© 2023 Carlisle SynTec a division of Carlisle Construction Materials Incorporated

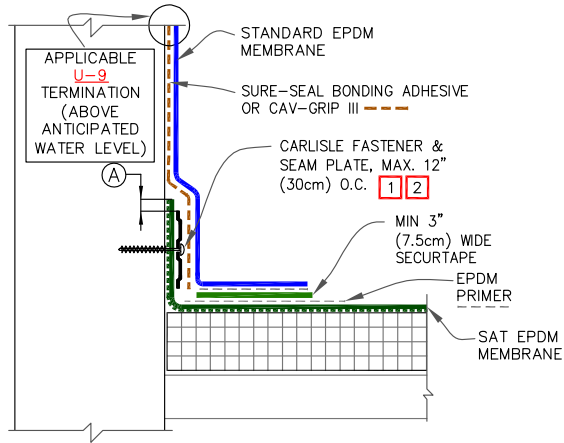



DIMENSION		cm
(A)	1/8"–1"	0.5–2.5
(B)	3"	7.5

NOTES:

1. SEAM FASTENING PLATE/FASTENER MAY BE INSTALLED INTO THE STRUCTURAL DECK ALSO.
2. FASTENRES AND PLATES REQUIRED AT 6" (7.5cm) O.C. FOR WARRANTY WIND SPEEDS EXCEEDING 90 MPH.
3. APPLY PRESSURE SENSITIVE ELASTOFORM FLASHING COVERING VERTICAL SPLICE INTERSECTIONS.

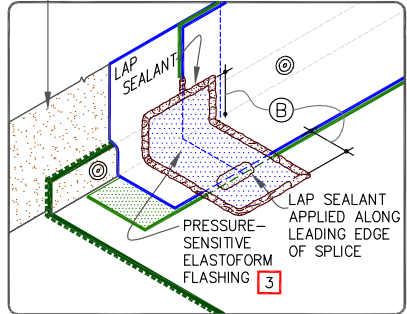
SURE-SEAL BONDING ADHESIVE OR CAV-GRIP III



	PARAPET/CURB WITH SEPARATE REGULAR EPDM FLASHING	 DETAIL NO. SAT-12B SELF ADHERING TECHNOLOGY
	MAXIMUM WARRANTY: 20 YEARS	

© 2023 Carlisle SynTec a division of Carlisle Construction Materials Incorporated

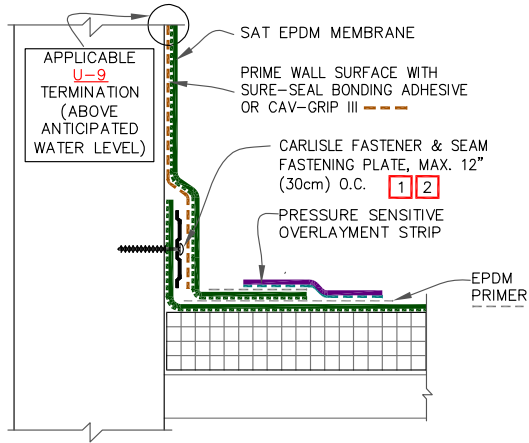

SURE-SEAL BONDING ADHESIVE OR CAV-GRIP III

DIMENSIONS	cm
(A)	3" / 7.5

NOTES:

1. SEAM FASTENING PLATE/FASTENER MAY BE INSTALLED INTO THE STRUCTURAL DECK ALSO.
2. FASTENERS AND PLATES REQUIRED AT 6" (7.5cm) O.C. FOR WARRANTY WIND SPEEDS EXCEEDING 90 MPH.
3. APPLY PRESSURE SENSITIVE ELASTOFORM FLASHING COVERING VERTICAL SPLICE INTERSECTIONS.

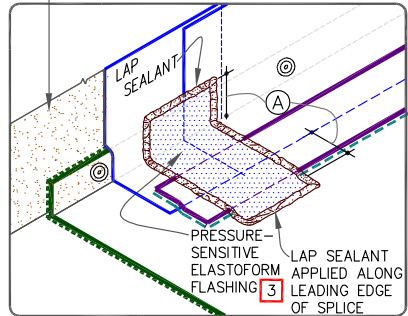

	PARAPET/CURB WITH SEPARATE SAT EPDM	SELF ADHERING TECHNOLOGY	DETAIL NO.
	MAXIMUM WARRANTY: 20 YEARS		SAT-12C

THERMOSET MEMBRANE

SAT EPDM

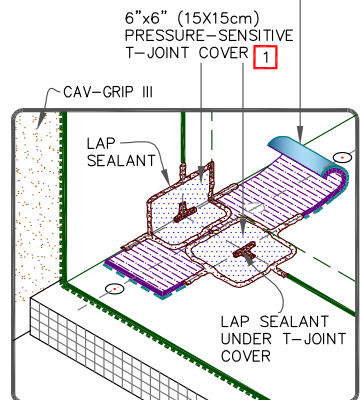
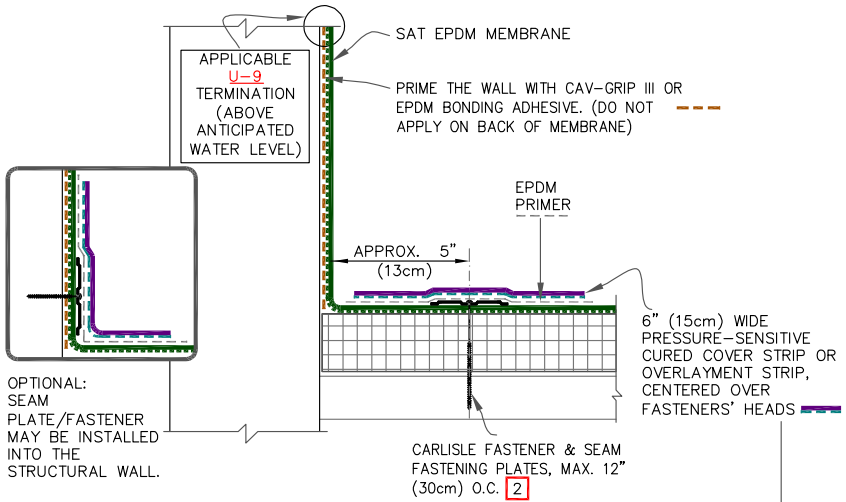

NOTES:

1. T-JOINTS CAN BE ELIMINATED WHEN PRESSURE-SENSITIVE OVERLAYMENT STRIP IS USED.
2. FASTENERS AND PLATES REQUIRED AT 6" (7.5cm) O.C. FOR WARRANTY WIND SPEEDS EXCEEDING 90 MPH.

	PARAPET/CURB WITH CONTINUOUS MEMBRANE – COVER STRIP	DETAIL NO. SAT-12D SELF ADHERING TECHNOLOGY
	MAXIMUM WARRANTY: 20 YEARS	

© 2023 Carlisle SynTec a division of Carlisle Construction Materials Incorporated

LIQUISEAL Liquid Flashing

The information contained in this supplement serves as a criteria for Specifiers and Authorized Applicators regarding the design and installation of Carlisle Roofing Systems and use of liquid flashing to complete tie-in details and flash unusual and round penetrations. In addition to the information contained herein, attachment details 1 through 3 are included to provide the Specifiers and Authorized Applicators with quick access to specific information. Specifiers and Authorized Applicators are advised to reference all applicable details included with this spec supplement.

A. General

LIQUISEAL Liquid Flashing is a two-component, polyurethane-based system which creates a reinforced, cold-applied liquid flashing that is compatible with all Carlisle EPDM membranes. LIQUISEAL Liquid Flashing is designed for use with oddly shaped penetrations and tying together dissimilar roofing systems without building an isolation curb or impeding drainage. LIQUISEAL Liquid Flashing is UV- and color-stable, solvent-free, low-VOC, and virtually odorless.

LIQUISEAL Liquid Flashing consists of the following products:

1. LIQUISEAL Resin – Two-component polyurethane-based resin, when mixed will be white in color. Available in 0.56 gallon (2.1 l) sachets and 1.03 gallon (3.9 l) pails. Coverage rate of 13.6 square feet (1.26 meters square) per gallon (3.8 l).
2. LIQUISEAL Fleece – 50-mil thick, white, Non-woven, needle-punched polyester fabric reinforcement. Available in rolls of 13.8" (350 mm) and 27" (685 mm) widths by 164'-0" (50 m) length.
3. LIQUISEAL Metal Primer – A solvent-free, high solids, two-part, cold-applied polyurethane resin. Used to prime metal, and other non-porous surfaces. Available in 0.25 gallon (0.9 l) sachets. Coverage rate of 25 square feet (2.3 square meters) per 0.25 gallon (0.9 l) sachet.
4. LIQUISEAL Concrete & Masonry Primer – A solvent-free, two-part, cold-applied liquid epoxy resin. Used with Surfacing Sand to prime concrete, masonry, and other porous surfaces. Available in 0.25 gallon (0.9 l) sachets and 1.1 gallon (4.2 l) pails. Coverage rate of 19 square feet (1.76 square meters) per 0.25 gallon (0.9 l) sachet.
5. LIQUISEAL Spiral Mixing Agitator – A 3" (7.62 cm) long steel spiral agitator with a ½" (1.27 cm) hex drive for use with handheld drills and mixers. Used to properly mix resin.
6. LIQUISEAL Surfacing Sand – Kiln-dried #00 - #35 graded sand suitable for broadcasting into LIQUISEAL Liquid Flashing Concrete & Masonry Primers for use in substrate preparation. Used with Concrete & Masonry Primer to promote proper adhesion and mechanical bond. Packaged in 50lb (22.6 kg) bags.

B. Warranty

Projects meeting the conditions below can be eligible for a maximum 20 year System Warranty with wind speed coverage up to 90 mph peak gusts. Projects requiring extended wind speed coverage warranty must be submitted to Carlisle for review prior to installation.

C. Precautions

1. Always store in a cool, dry location between 35°F – 80°F (1.7°C – 27°C). Do not store in direct sunlight. Approximate shelf life is 12 months with proper storage. Best practice is to store material at 65°F – 70°F (18°C – 21°C) for 24 hours before use.
2. Do not install if ambient temperature is below 40°F (4°C) or above 90°F (32°C).
3. Do not break down work packs into smaller quantities; mix the entire work pack.
4. Prepare surfaces and pre-cut all fleece before mixing resin. Pot life will be shorter as ambient temperature rises.
5. Use appropriate safety glasses and protect hands and wrists by wearing gloves.

D. Installation

1. **Surface Preparation:** Prepare all substrates by removing any irregularities and any loose or foreign material such as dirt, water, grease, oil, lacquers, or release agents. Prepare membrane by sanding with 60-grit sandpaper.
2. **Metal Primer Application:**
 - a. All metal surfaces must be prepared using a grinder. Do not use a wire brush. Ensure that all metal surfaces are ground down to expose bare metal.
 - b. Remove bag from the aluminum packaging. Knead cream-colored resin (Component A) thoroughly until a uniform color is achieved.
 - c. Pull away the rubber cord separating the two components so that Components A and B can be mixed together. Knead the bag quickly and thoroughly for approximately 1 minute so that a homogenous primer is formed. The primer should be a uniform color, with no light or dark streaks present.
 - d. After the primer is mixed, cut off one corner of the bag and pour all primer into a clean, new mixing pail. Working quickly, apply approximately 25 square feet (2.3 square meters) per 0.25 gallon (0.9 l) sachet. The primer should be rolled or brushed evenly onto the surface in a cross-directional method to fully cover the substrate in one application. Allow to set for approximately 3 hours or until fully cured prior to application of the LIQUISEAL Liquid Flashing Resin.

Note: LIQUISEAL Liquid Flashing Resin must be applied when the primer is completely dry and without tack. Do not apply LIQUISEAL Liquid Flashing Resin to tacky or wet primer.

3. **Concrete & Masonry Primer Application:**
 - a. Prepare all substrates by removing any irregularities and any loose or foreign materials such as dirt, water, grease, oil, lacquers, or release agents using a grinder. All concrete substrates should be dry and fully cured.
 - b. Remove bag from the aluminum packaging. Knead translucent yellow resin (Component A) thoroughly until a uniform color is achieved.
 - c. Pull away the rubber cord separating the two components so that Components A and B can be mixed together. Knead the bag quickly and thoroughly for approximately 1 minute so that a homogenous primer is formed. The primer should be a uniform color, with no light or dark streaks present.
 - d. After the primer is mixed, cut off one corner of the bag and pour all primer into a clean, new mixing pail. Working quickly, apply at a rate of approximately 19 square feet (1.76 square meters) per 0.25 gallon (0.9 l) sachet. The primer should be rolled or brushed evenly onto the surface in a cross directional method to fully cover the substrate in one application.
 - e. After applying the primer, immediately broadcast LIQUISEAL Liquid Flashing Concrete & Masonry Preparation Sand into the uncured primer at the approximate rate of 50 lbs (22.6 kg) per 100 square feet (9.29 square meters). Allow to set for approximately 4 hours or until fully cured prior to application of the LIQUISEAL Liquid Flashing Resin.
 - f. In warm climates, higher contents of moisture or vapor within a concrete substrate may cause pin-holing of the primer due to vapor drive. Applying primer later in the day when temperatures are lower can improve this condition.

Note: LIQUISEAL Liquid Flashing Resin must be applied when the primer is completely dry and without tack. Do not apply LIQUISEAL Liquid Flashing Resin to tacky or wet primer.

4. LIQUISEAL Liquid Flashing Application:
 - a. Apply the appropriate primer to membrane and allow to flash off. Apply appropriate primer to all other surfaces to which flashing will be applied.
 - b. Cut and prepare all reinforcing fleece before mixing resin.
 01. For LIQUISEAL Resin in 1.03 gallon (3.9 l) Pail Packaging
 - i. Mix resin (Component A) with a clean spiral agitator until the liquid is a uniform white color.
 - ii. Add hardener (Component B) to Component A and mix with a spiral agitator for 2 minutes or until both liquids are thoroughly blended.
 02. For LIQUISEAL in 0.25 gallon (0.9 l) Sachet Packaging
 - i. Remove bag from the aluminum packaging.
 - ii. Knead white resin (Component A) thoroughly until a uniform color is achieved.
 - iii. Pull away the rubber cord separating the two components so that Components A and B can be mixed together. Knead the bag quickly and thoroughly for approximately 1 minute so that a homogenous resin is formed. The resin should be a uniform color, with no light or dark streaks present.
 - iv. After the resin is mixed, cut off one corner of the bag and pour entire sachet of resin into a clean, new mixing pail. Working quickly, apply at a rate of approximately 13.6 square feet (1.3 square meter) per gallon (3.8 l).
 - c. Using a nap roller or brush, apply two-thirds of the resin evenly onto the substrate using even strokes.
 - d. Roll the LIQUISEAL Liquid Flashing Fleece directly into the LIQUISEAL Liquid Flashing Resin, ensuring that the SMOOTH SIDE IS FACING UP (natural unrolling procedure) and avoiding folds, wrinkles, and air pockets.
 - e. Apply the remaining one-third of the resin and use the roller or brush to work the resin into the fleece, saturating from the bottom up. All areas of the fleece should be completely saturated with resin.
 - f. Repeat steps 'b through e' again for subsequent layers of resin and flashing as needed for detailing.



Scan here to view Liquid Flashing Installation Videos.

LIQUID FLASHING

EPDM/TPO/PVC

Notes:

- The following tables provide recommendations for preparation and priming of substrates and should be used as a guideline for proper adhesion & performance.
- The primer application rate will vary and should be adjusted depending on the substrate. See Product Data Sheets, SDS, Guide Specifications and Details for complete information regarding the suitability, application and handling of products.

INSPECTION		EPDM	TPO	PVC / KEE / HP	METAL SURFACES	MASONRY
A.1	Inspect insulation for wet conditions underneath the roof membrane. Remove & replace wet materials underneath to match in kind.	Y	Y	Y		
A.2	Ensure, membrane or roof assembly is properly secured.	Y	Y	Y		
A.3	Provide additional securement at the base of penetrations, tie-ins or angle changes per details.	Y	Y	Y		
A.4	Ensure, there is no standing water. Remove and dry the work area. Remove dust, debris and wipe the work surfaces clean. Masonry must be completely dry and sound.	Y	Y	Y	Y	Y
A.5	Verify structural integrity of metal objects. Check for broken welds or loose bolts. Verify the thickness of exposed metal after removal of finishes or rust for strength.				Y	
A.6	Ensure, there is no moisture present in the substrate.	Y	Y	Y	Y	Y
A.7	Within the work area, inspect the seams of existing membrane for proper seal.	Y	Y	Y		
A.8	Do not damage structural members, welds or remove any nuts/bolts unless approved by designer.				Y	
CLEANING & SUBSTRATE PREPARATION		EPDM	TPO	PVC / KEE / HP	METAL SURFACES	MASONRY
B.1	Use 60 grit sandpaper to rough up the top surface of the membrane.	Y	Y	Y		
B.2	Use abrasive grinding wheel (a diamond cup wheel is suggested) to expose the bare metal (do not use wire brush). Expose metal around nuts & tighten as needed. Wipe the membrane cleaner.				Y	Y
B.3	Remove dust, clean the surfaces with broom & power blower.	Y	Y	Y	Y	Y
B.4	Wipe the surfaces with Carlisle Membrane Cleaner , (Standard or Low VOC)	Y	Y	Y	Y	
B.5	Use painter's tape to contain flashing resin. Tape shall be set 1/4" to 1/2" (1-1.5cm) beyond the fleece edges.	Y	Y	Y	Y	Y
EXISTING BITUMINOUS ROOFING SUBSTRATES					CONCRETE & MASONRY PRIMER	
C.1	Modified Bitumen Smooth APP Surfaced.	Power wash to remove contaminants.			Y	
C.2	Modified Bitumen Smooth SBS Surfaced.					
C.3	Bituminous Roofing – Granular Surfaced.	Power wash to remove contaminants & loose granules				
C.4	Following bituminous substrates are not acceptable: Aluminum coating, flood coat & aggregate, coal tar pitch roofing – flood coat & aggregate, hot-melt bituminous waterproofing & ethylene-faced bituminous (bituthane) roofing.					

INSPECTION CLEANING & SUBSTRATE PREPARATION (PAGE 1 OF 2)		ATTACHMENT 1
For additional information, refer to Spec. Supplement	LIQUID FLASHING	

© 2023 Carlisle SynTec a division of Carlisle Construction Materials Incorporated

METAL SUBSTRATES			METAL PRIMER
D.1	Bare aluminum, lead, copper & zinc.	Grind to remove corrosion, then use membrane cleaner to wipe and clean.	Ⓚ
D.2	Bare steel, galvanized steel.		
D.3	Black pipe, cast iron.	Grind to remove corrosion and coating. Then use membrane cleaner to wipe and clean.	Ⓚ
D.4	Stainless steel.	Grind to achieve rough surface. Then use membrane cleaner to wipe and clean.	Ⓚ
D.5	Kynar finish, ceramic coated, and painted metal.	Grind to remove coating. Then use membrane cleaner to wipe and clean.	Ⓚ
CEMENTITIOUS AND MASONRY SUBSTRATES			MASONRY PRIMER
E.1	Structural & or lightweight structural concrete.	Scarify, shot blast or grind to remove laitance and open up pores	Ⓚ
E.2	Granite, Marble.	Scarify, shot blast, grind to remove polished surface and open up pores	Ⓚ
E.3	Clay brick, terra cotta, tile.	Scarify, shot blast, grind to remove glazed surface and open up pores.	Ⓚ
E.4	Sandstone, limestone, synthetic stone.	Scarify, shot blast, grind to open up pores	Ⓚ
E.5	Porous/air-entrained concrete, concrete masonry block.		
E.6	Repair & leveling mortars.		
GLASS & PLASTIC SUBSTRATES			METAL PRIMER
F.1	Glass.	Sand to abrade surface. Then use membrane cleaner to wipe and clean.	Ⓚ
F.2	Acrylic.		
F.3	Fiberglass.		
F.4	ABS, PVC – Rigid.		

Note: Contact Carlisle SynTec for substrate not listed in these tables.

CAUTION:

All substrates must be prepared as necessary prior to the application of primers. Surfaces must be free from irregularities, loose, unsound or foreign materials such as rust, dirt, ice, snow, water, grease, oil, release agents, paint, lacquers, coatings, or any other conditions that would be detrimental to adhesion of the primer and resin.

INSPECTION CLEANING & SUBSTRATE PREPARATION (PAGE 2 OF 2)		ATTACHMENT 1
For additional information, refer to Spec. Supplement	LIQUID FLASHING	

LIQUISEAL PRIMER & RESIN APPLICATION		EPDM	TPO	PVC / KEE / HP	METAL SURFACES	MASONRY
G.1	Ensure all surfaces are ready for application of primer prior to mixing, due to limited pot life.	Y	Y		Y	Y
G.2	Mix primer thoroughly, per specifications.	Y	Y		Y	Y
G.3	Apply LIQUISEAL Metal Primer per specifications.	Y			Y	
G.4	Masonry: Apply LIQUISEAL Concrete & Masonry Primer and surfacing sand per specifications.					Y
G.5	Wait for primer to cure per written instructions.	Y			Y	Y
G.6	Apply Low VOC Primer and allow to flash off completely.		Y			
G.7	Cut & dry-fit all fleece prior to mixing resin. Ensure, the fleece is set back from painter's tape, per B.5 .	Y	Y	Y	Y	Y
G.8	Mix LIQUISEAL Flashing Resin thoroughly (with spiral agitator if in pail).	Y	Y	Y	Y	Y
G.9	Apply a base layer of LIQUISEAL Flashing Resin ensuring generous coverage of entire substrate.	Y	Y	Y	Y	Y
G.10	Immediately press LIQUISEAL Flashing Fleece into the applied LIQUISEAL Flashing Resin , taking care at corners and crevices.	Y	Y	Y	Y	Y
G.11	Apply a 2nd (top coat) of LIQUISEAL Flashing Resin , ensuring the fleece is completely saturated per published coverage rate.	Y	Y	Y	Y	Y

APPLICATION OF LIQUISEAL PRIMER & RESIN		ATTACHMENT 2
For additional information, refer to Spec. Supplement	LIQUID FLASHING	

© 2023 Carlisle SynTec a division of Carlisle Construction Materials Incorporated

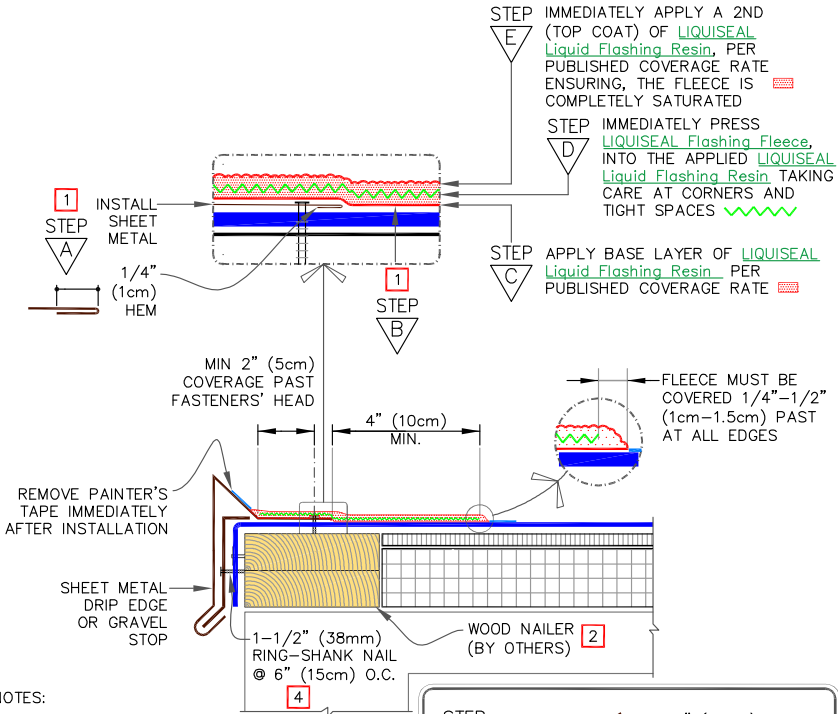

NOTES:

1. REFER TO TABLES ON SHEETS ATTACHMENT 1-2 FOR DETAILED INSPECTION, CLEANING AND PRIMING FOR DIFFERENT MATERIALS WITHIN THE FLASHING AREAS.
2. WOOD NAILER MUST EXTEND PAST TOTAL WIDTH OF SHEET METAL FLANGE.
3. SAME DETAIL APPLIES AT THE TOP OF PARAPET WALL, WHERE FULL COPING IS NOT USED.
4. FASTENERS MUST BE SECURED INTO STRUCTURAL MEMBERS, E.G., CONCRETE, SOLID MASONRY OR WOOD BLOCKING.
5. DETAIL NOT FOR USE ON WARRANTY PROJECTS EXCEEDING 20-YEARS, UNLESS OTHERWISE SPECIFIED.

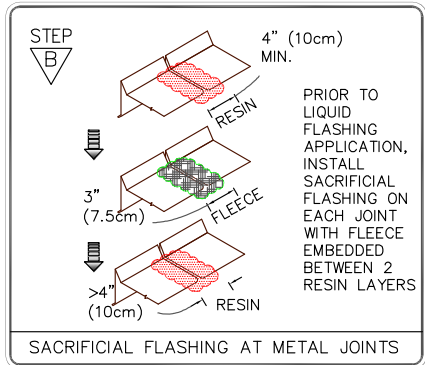

	<p>SHEET METAL DRIP EDGE OR GRAVEL STOP FLASHING</p> <p>For additional information, refer to Specifications</p>	<p>DETAIL NO.</p> <p>LF-1.1</p> <p>LIQUID FLASHING</p>
--	---	--

LIQUID FLASHING

EPDM/TPO/PVC

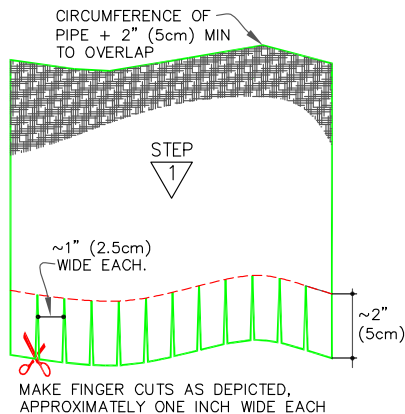

APPLY BASE COAT OF LIQUISEAL Liquid Flashing Resin PER PUBLISHED COVERAGE RATE

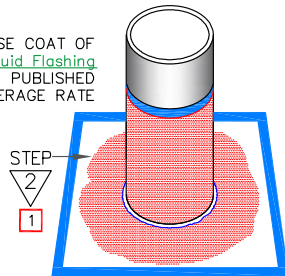

APPLY BASE COAT OF LIQUISEAL Liquid Flashing Resin ON HORIZONTAL SURFACES. IMMEDIATELY PRESS FLEECE INTO RESIN AND OVERLAP LIQUISEAL Liquid Flashing Fleece, MIN. 2" (5cm)

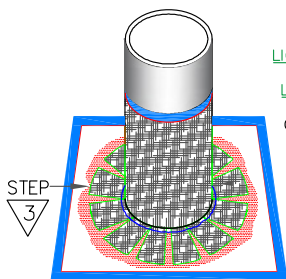

IMMEDIATELY PRESS LIQUISEAL Flashing Fleece INTO THE APPLIED LIQUISEAL Liquid Flashing Resin. APPLY SECOND COAT OF RESIN. ENSURE ALL ENDS OF FINGERS ARE PROPERLY EMBEDDED.

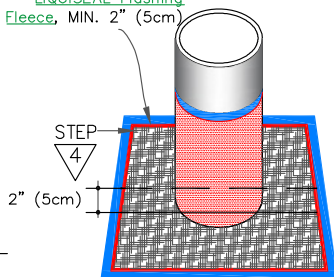

FLEECE MUST BE COVERED 1/4" - 1/2" (1cm - 1.5cm) PAST ALL EDGES

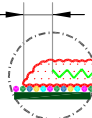

NOTES:

1. FOR MULTIPLE PIPE PENETRATIONS SEE STEP ZERO ON SHEET LF-8.1 (PAGE 2 OF 2) AND FOLLOW REST OF THE STEPS AS SHOWN FOR SINGLE PIPE FLASHING.
2. REFER TO TABLES ON SHEETS ATTACHMENT 1-2 FOR DETAILED INSPECTION, CLEANING AND PRIMING FOR DIFFERENT MATERIALS WITHIN THE FLASHING AREAS.
3. SEE PAGE 2 OF 2 FOR ADDITIONAL NOTES.

APPLY A TOP COAT OF LIQUISEAL Liquid Flashing Resin, ENSURING THE FLEECE IS COMPLETELY SATURATED PER PUBLISHED COVERAGE RATE AND APPLY 1/4"-1/2" (1cm-1.5cm) BEYOND THE FLEECE EDGES

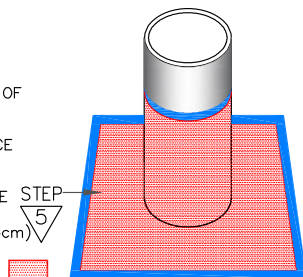

	→ ROOF MEMBRANE
	→ LIQUISEAL Flashing Fleece
	→ LIQUISEAL Liquid Flashing Resin
	→ SEE NOTE(S)

SINGLE OR MULTIPLE PIPE PENETRATIONS (PAGE 1 OF 2)

For additional information, refer to Specifications



DETAIL NO.

LF-8.1

LIQUID FLASHING

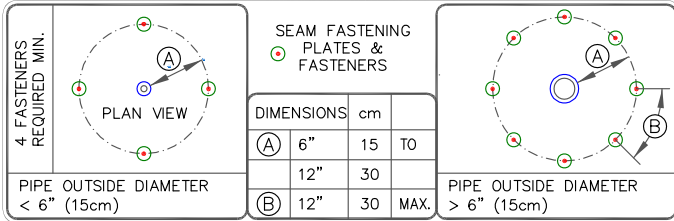
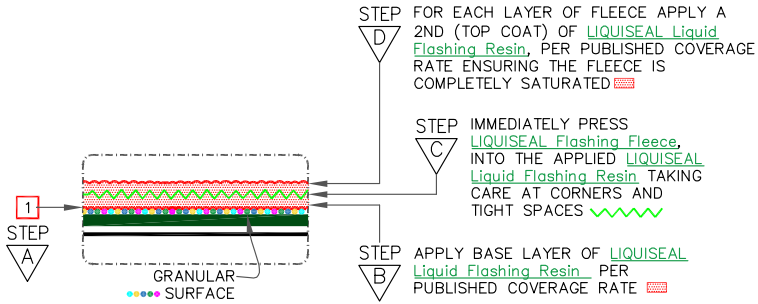
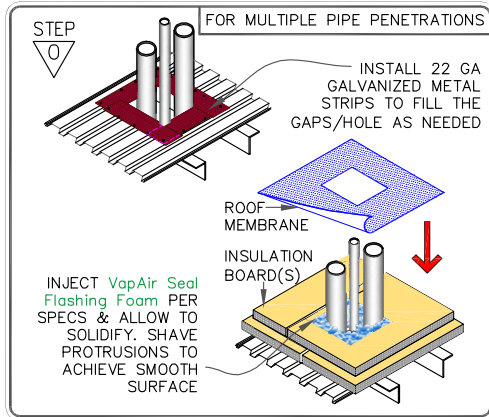

TABLE FOR FASTENER REQUIREMENTS ON MECHANICALLY FASTENED SYSTEMS. REFER TO CARLISLE TYPICAL PENETRATION DETAILS FOR FLASHING OVER FASTENER HEADS.

NOTES CONTINUE FROM **LF-8.1 (PAGE 1 OF 2)**

- WHEN THERE IS ENOUGH CLEARANCE BETWEEN MULTIPLE PENETRATIONS, INSTALL LIQUID FLASHING USING THIS DETAIL.
- WHEN INSTALLATION OF LIQUID FLASHING IS NOT FEASIBLE FOR MULTIPLE PIPE PENETRATIONS, THEN USE APPLICABLE STANDARD ROOF MEMBRANE DETAIL (**U-16**) FOR FIELD MEMBRANE TYPE.
- DETAIL NOT FOR USE ON WARRANTY PROJECTS EXCEEDING 20-YEARS, UNLESS OTHERWISE SPECIFIED.



→ ROOF MEMBRANE → LIQUISEAL Flashing → LIQUISEAL Liquid Flashing Resin → SEE NOTE(S)	SINGLE OR MULTIPLE PIPE PENETRATIONS (PAGE 2 OF 2) For additional information, refer to Specifications	DETAIL NO. LF-8.1 LIQUID FLASHING
---	---	--

LIQUID FLASHING

EPDM

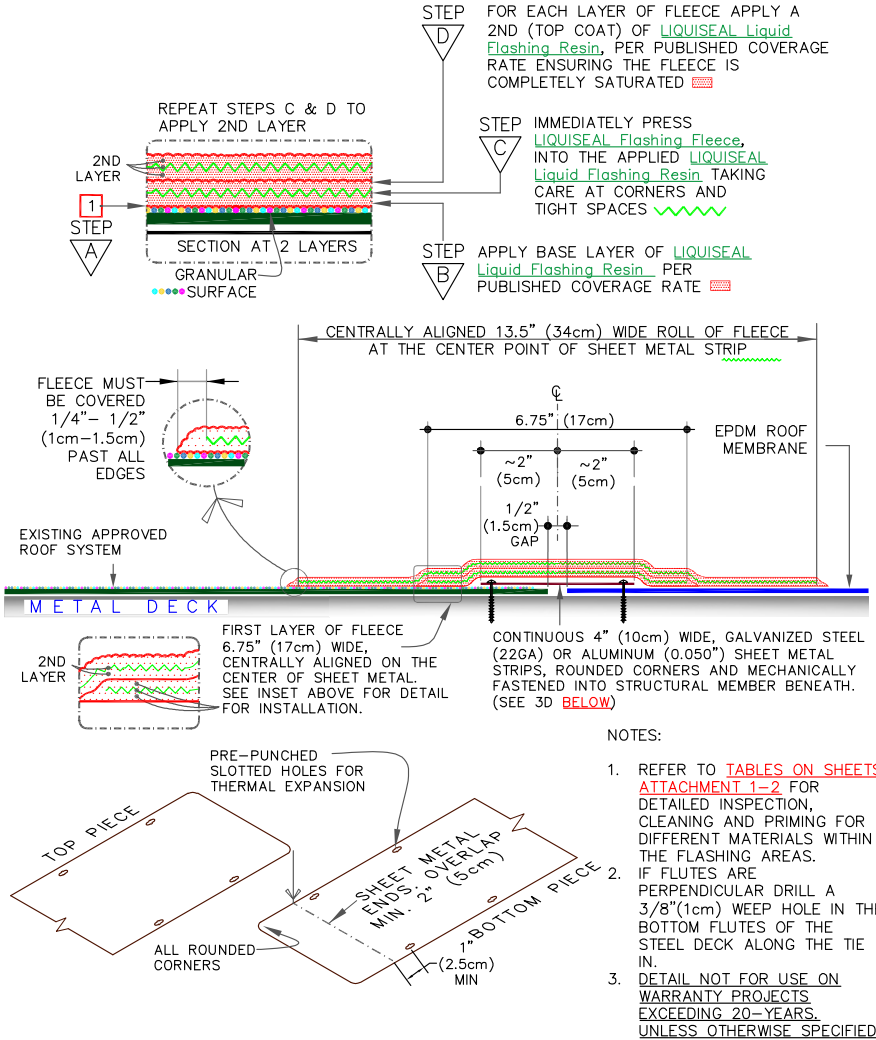

	<p>EPDM MEMBRANE TIE-IN WITH EXISTING ROOF OVER STEEL DECK</p> <p>For additional information, refer to Specifications</p>		<p>DETAIL NO.</p> <p>LF-13.1</p> <p>LIQUID FLASHING</p>
--	---	--	---

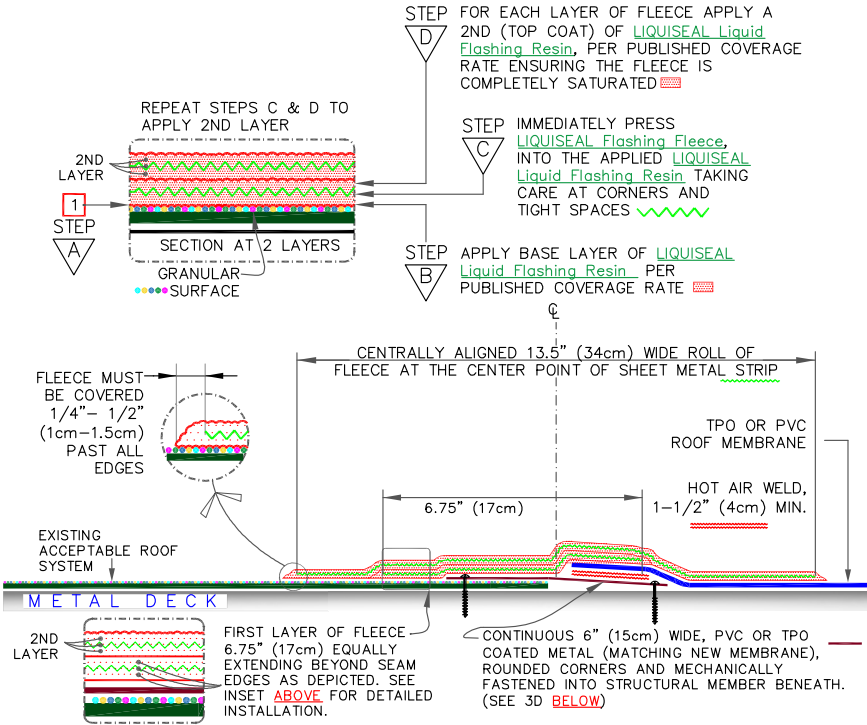

NOTES:

- REFER TO TABLES ON SHEETS ATTACHMENT 1-2 FOR DETAILED INSPECTION, CLEANING AND PRIMING FOR DIFFERENT MATERIALS WITHIN THE FLASHING AREAS.
- IF FLUTES ARE PERPENDICULAR DRILL A 3/8" (1cm) WEEP HOLE IN THE BOTTOM FLUTES OF THE STEEL DECK ALONG THE TIE IN.
- DETAIL NOT FOR USE ON WARRANTY PROJECTS EXCEEDING 20-YEARS, UNLESS OTHERWISE SPECIFIED.

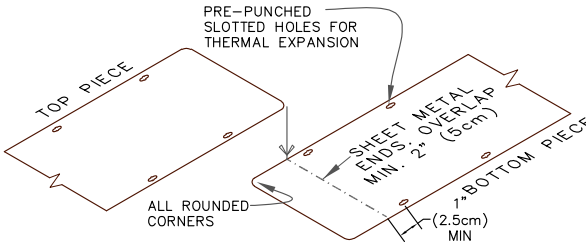

<p>ROOF MEMBRANE</p> <p>LIQUISEAL Flashing Fleece</p> <p>LIQUISEAL Liquid Flashing Resin</p> <p>SEE NOTE(S)</p>	<p>TPO OR PVC MEMBRANE TIE-IN WITH EXISTING ROOF OVER STEEL DECK (PAGE 1 OF 2)</p> <p>For additional information, refer to Specifications</p>	<p>DETAIL NO.</p> <p>LF-13.2</p> <p>LIQUID FLASHING</p>
---	---	---

LIQUID FLASHING

TPO/PVC



INSTALL COATED SHEET METAL STRIPS WITH THREADED FASTENERS. REFER TO TABLES ON SHEETS [ATTACHMENT 1-2](#) FOR DETAILED INSPECTION, CLEANING AND PRIMING FOR DIFFERENT MATERIALS WITHIN THE FLASHING AREAS.

A



B

PROPERLY CLEAN WITH MEMBRANE CLEANER PRIOR TO WELDING.

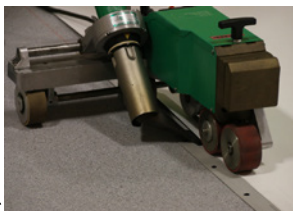

C

WELD TPO OR PVC MEMBRANE TO COATED METAL STRIP.



D

USE SAND PAPER GRIT # 60 TO ABRASE THE AREAS TO WHICH THE LIQUISEAL FLASHING RESIN WILL BE APPLIED.



E

THOROUGHLY CLEAN THE TIE-IN AREA.



F

CUT TWO PIECES OF [LIQUISEAL Flashing Fleece](#). (FOR DIMENSIONS SEE [LF-13.2A](#)).



G

APPLY PAINTER'S TAPE ALONG TIE-IN EDGE.



H

THOROUGHLY MIX THE RESIN, PER PUBLISHED INSTRUCTIONS.



INSTALL BOTH LAYERS OF PRE-CUT [LIQUISEAL Flashing Fleece](#), EMBEDDED IN RESIN (SEE [LF-13.2A](#)).

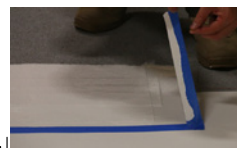

J

REMOVE TAPE IMMEDIATELY ENSURING THAT RESIN EXTENDS 1/4" - 1/2" BEYOND EDGE OF FLEECE.

	→ ROOF MEMBRANE
	→ LIQUISEAL Flashing Fleece
	→ LIQUISEAL Liquid Flashing Resin
	→ SEE NOTE(S)

TPO OR PVC MEMBRANE TIE-IN WITH EXISTING ROOF OVER STEEL DECK (PAGE 2 OF 2)

For additional information, refer to Specifications

	DETAIL NO.
	LF-13.2
LIQUID FLASHING	

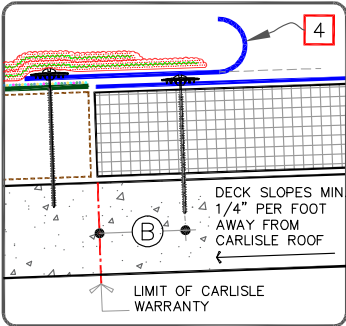
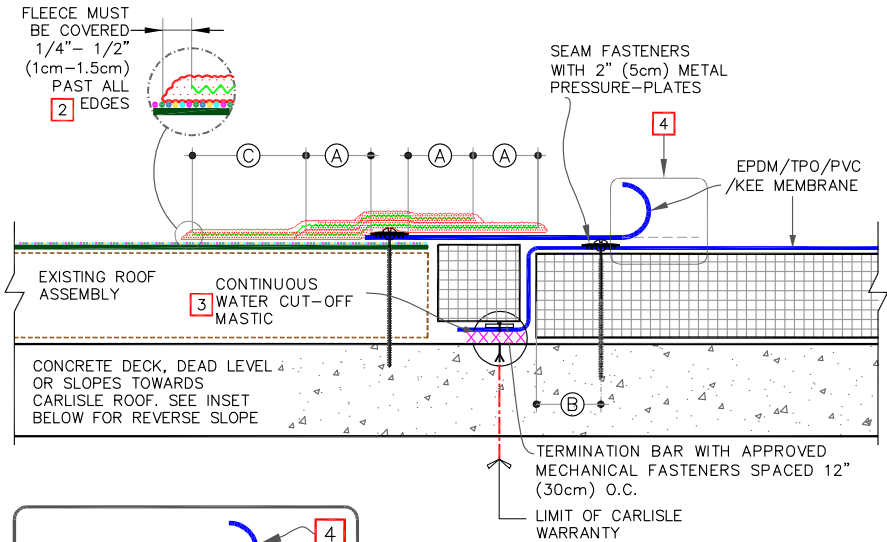

NOTES:

- REFER TO TABLES ON [SHEETS ATTACHMENT 1-2](#) FOR DETAILED INSPECTION, CLEANING AND PRIMING FOR DIFFERENT MATERIALS WITHIN THE FLASHING AREAS.
- DETAIL NOT FOR USE ON WARRANTY PROJECTS EXCEEDING 20-YEARS. UNLESS OTHERWISE SPECIFIED.
- PROPERLY FILL THE JOINTS, VOIDS AND CRACKS ENSURING PROPER SEAL AGAINST WATER MIGRATION.
- APPLICABLE SEAM DETAILS:

- EPDM: [U-2A & U-2A.1](#)
- TPO/PVC/KEE: [U-2A](#)

DIMENSIONS	cm	
(A)	3"	7.5 MIN.
(B)	2-3"	5-7.5 MIN.
(C)	AS REQUIRED DEPENDING ON SUBSTRATE, BUT MIN. 4" (10cm).	

	<p>MEMBRANE TIE-IN WITH EXISTING ROOF OVER CONCRETE DECK</p> <p>For additional information, refer to Specifications</p>		<p>DETAIL NO.</p> <p>LF-13.3</p> <p>LIQUID FLASHING</p>
--	---	--	---

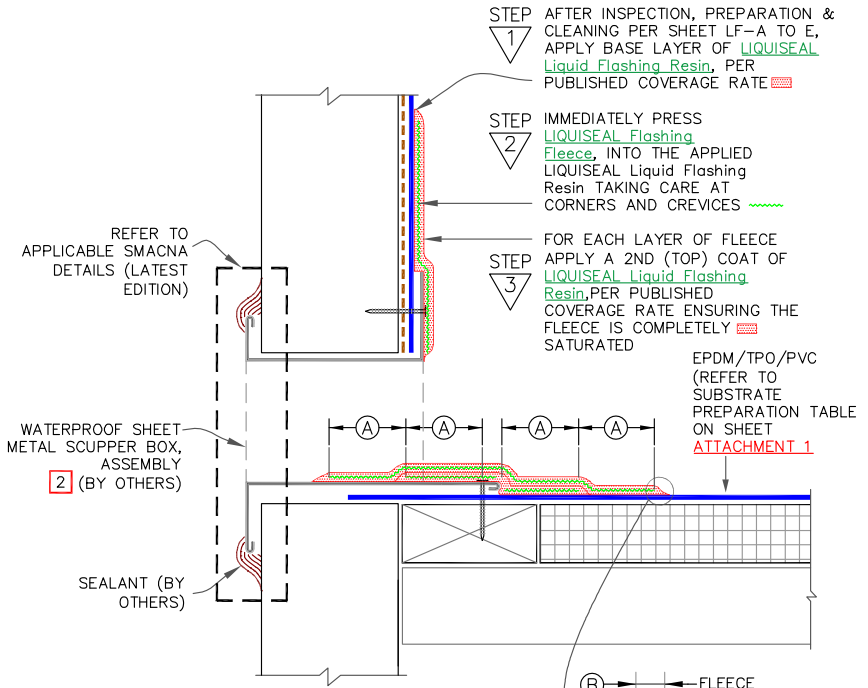

NOTES:

- REFER TO TABLES ON SHEETS ATTACHMENT 1-2 FOR DETAILED INSPECTION, CLEANING AND PRIMING FOR DIFFERENT MATERIALS WITHIN THE CONSTRUCTION AREA.
- WOOD NAILER MUST EXTEND PAST TOTAL WIDTH OF SHEET METAL FLANGE.
- MECHANICAL FASTENERS MUST BE SECURED INTO STRUCTURAL CONCRETE, SOLID MASONRY OR PRESSURE TREATED WOOD BLOCKING.
- DETAIL NOT FOR USE ON WARRANTY PROJECTS EXCEEDING 20-YEARS, UNLESS OTHERWISE SPECIFIED.

DIMENSIONS	cm	
(A)	3"	7.5 MIN.
(B)	1/4"	1 TO
	1/2"	1.5

	<p>THROUGH-WALL SCUPPER</p> <p>For additional information, refer to Specifications</p>	<p>DETAIL NO. LF-18.1</p> <p>LIQUID FLASHING</p>
--	--	---

INJECT VapAir Seal Flashing Foam PER SPECS & ALLOW TO SOLIDIFY. SHAVE PROTRUSIONS TO ACHIEVE SMOOTH SURFACE

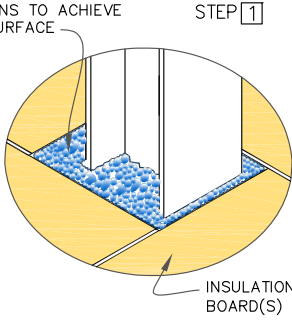

GRIND METAL WITH DIAMOND CUP GRINDING WHEEL

MEMBRANE SECURED WITH PLATES & FASTENERS PER SPECS

STEP 2

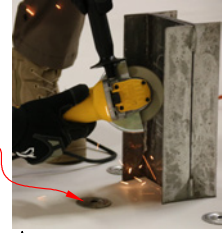

NOTE: ENSURE BODY OF PENETRATIONS & WELDS ARE COMPLETELY WATERPROOF.

DIAMOND CUP GRINDING WHEEL

STEP 3



USE SAND PAPER GRIT# 60 TO ABRAD THE MEMBRANE SURFACE.

STEP 4



REMOVE ALL GRINDING DUST, CLEAN METAL & MEMBRANE WITH CLEAN RAGS & MEMBRANE CLEANER.

STEP 5

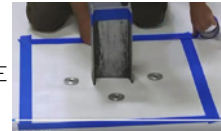

USE PAINTER'S TAPE AND TAPE OFF THE FLASHING AREA.

MEASURING, CUTTING & DRY FITTING TECHNIQUE

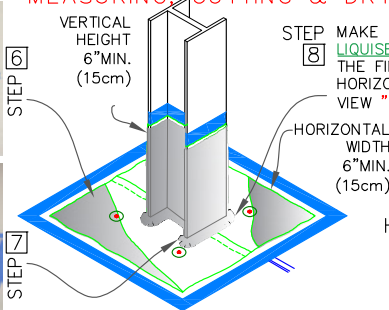

STEP 8 MAKE FINGER CUTS 2" (5cm) LONG IN LIQUISEAL Flashing Fleece AS SHOWN. THE FINGERS WILL REST ON THE HORIZONTAL SURFACE. SEE ENLARGED VIEW "1" ON PAGE 2 OF 2.

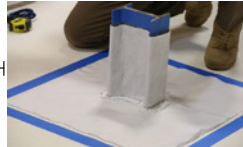
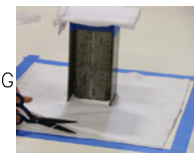

<p>— ROOF MEMBRANE</p> <p>— LIQUISEAL Flashing Fleece</p> <p>— LIQUISEAL Liquid Flashing Resin</p> <p>0 — SEE NOTE(S)</p>	<p>STEEL I-BEAM FLASHING (PAGE 1 OF 2)</p> <p>For additional information, refer to Specifications</p>	<p>DETAIL NO.</p> <p>LF-30.1</p> <p>LIQUID FLASHING</p>
---	---	---

LIQUID FLASHING

EPDM/TPO/PVC

SACHET MIXING AND PRIMER APPLICATION

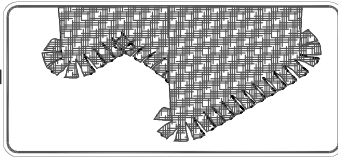

STEP 9

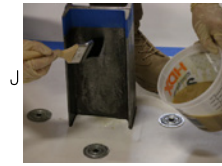

PRIME I-BEAM AND METAL PLATES. ENSURE AMBIENT AIR TEMPERATURE IS 40' & RISING. ALLOW PRIMER TO CURE UNTIL TACK-FREE.

STEP 10

APPLY 1ST COAT OF LIQUISEAL Liquid Flashing Resin & INSTALL LIQUISEAL Flashing Fleece ON VERTICAL SURFACES.

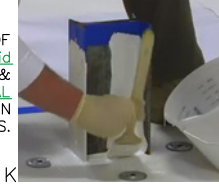

FLASHING FINAL INSTALLATION

STEP 11



IMMEDIATELY APPLY A 2ND COAT OF LIQUISEAL Liquid Flashing Resin ENSURING THE FLEECE IS COMPLETELY SATURATED.

APPLY 1ST COAT OF RESIN AND INSTALL FLEECE ON HORIZONTAL SURFACES. IMMEDIATELY APPLY A 2ND COAT OF RESIN ENSURING FLEECE IS COMPLETELY SATURATED.

STEP 12

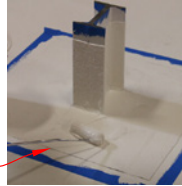

FLEECE MUST BE COVERED 1/4" - 1/2" (1cm - 1.5cm) BEYOND EDGES

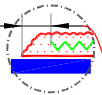

STEP 13

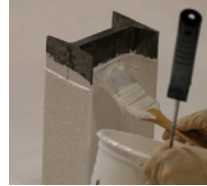

TOUCH UP AS NEEDED TO ENSURE ENTIRE FLEECE IS COMPLETELY SATURATED.

STEP 14

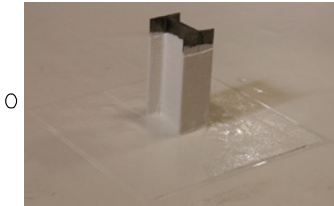

REMOVE TAPE IMMEDIATELY ENSURING THAT RESIN EXTENDS 1/4" - 1/2" (1cm - 1.5cm) BEYOND EDGE OF FLEECE

COMPLETED FLASHING

NOTE:
1. DETAIL NOT FOR USE ON WARRANTY PROJECTS EXCEEDING 20-YEARS, UNLESS OTHERWISE SPECIFIED.

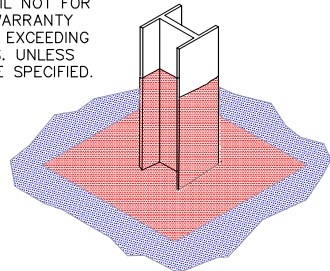

<p>→ ROOF MEMBRANE → LIQUISEAL Flashing → Fleece → LIQUISEAL Liquid Flashing Resin → SEE NOTE(S)</p>	<p>STEEL I-BEAM FLASHING (PAGE 2 OF 2)</p> <p>For additional information, refer to Specifications</p>	<p>DETAIL NO. LF-30.1</p> <p>LIQUID FLASHING</p>
--	---	---

ROOF ASSEMBLY WITHOUT NEW INSULATION

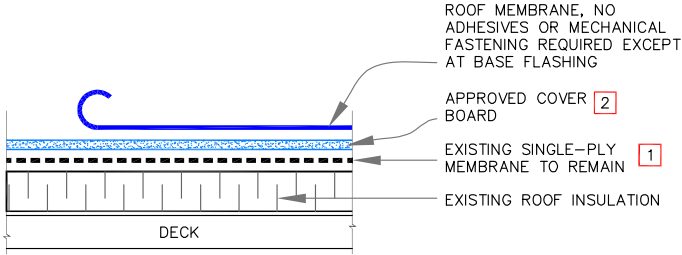

NOTE:

- EXISTING ROOF MEMBRANE MAY BE USED AS AN AIR BARRIER. IT WILL REQUIRE THOROUGH INSPECTION FOR BREACHES, DAMAGES, AND AIR TIGHTNESS OF EXISTING FLASHING. SEAL ALL DEFICIENT CONDITIONS TO ACHIEVE AN AIRTIGHT AIR BARRIER.
- DIRECT OVERLAYS (NO NEWLY INSTALLED INSULATION OR COVERBOARD) MAY BE ACCEPTABLE DEPENDING ON THE EXISTING WATERPROOFING LAYER AND NEWLY INSTALLED MEMBRANE. REFERENCE SUBSTRATE CRITERIA FOR VACUSEAL REROOF (RECOVER, NO TEAR-OFF) CHART FOR DETAILS.

ROOF ASSEMBLY WITH NEW INSULATION

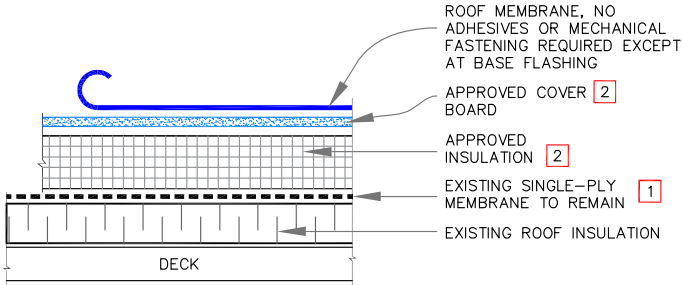

	ROOF ASSEMBLY OVER EXISTING SINGLE-PLY ROOF		DETAIL NO.
	MAXIMUM WARRANTY: 20 YEARS		V-0.1

VacuSeal Vent Secured Roofing System

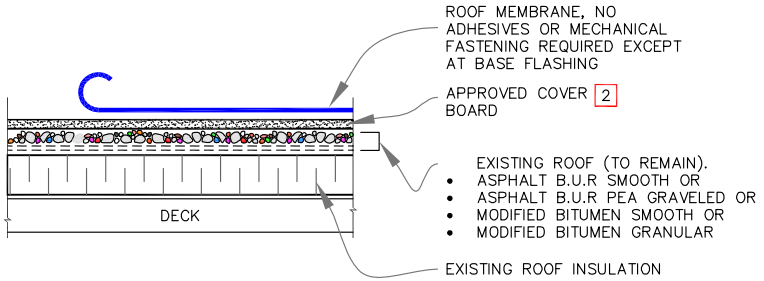

NOTES:

1. EXISTING ROOF MEMBRANE MAY BE USED AS AN AIR BARRIER. IT WILL REQUIRE THOROUGH INSPECTION FOR BREACHES, DAMAGES, BLISTERS, WRINKLES AND AIR TIGHTNESS OF EXISTING FLASHING. SEAL ALL DEFICIENT CONDITIONS TO ACHIEVE AN AIRTIGHT AIR BARRIER.
2. DIRECT OVERLAYS (NO NEWLY INSTALLED INSULATION OR COVERBOARD) MAY BE ACCEPTABLE DEPENDING ON THE EXISTING WATERPROOFING LAYER AND NEWLY INSTALLED MEMBRANE. REFERENCE SUBSTRATE CRITERIA FOR VACUSEAL REROOF (RECOVER, NO TEAR-OFF) CHART FOR DETAILS.
3. FOR NEW ASSEMBLY OVER COAL TAR PITCHED ROOF, CONTACT CARLISLE SYNTEC.
4. LOOSE GRAVEL OR GRANULES MUST BE REMOVED AND THE SURFACE SHALL BE LEVELED.

	ROOF ASSEMBLY OVER EXISTING ASPHALTIC ROOF		DETAIL NO.
	MAXIMUM WARRANTY: 20 YEARS		V-0.2

© 2023 Carlisle SynTec a division of Carlisle Construction Materials Incorporated

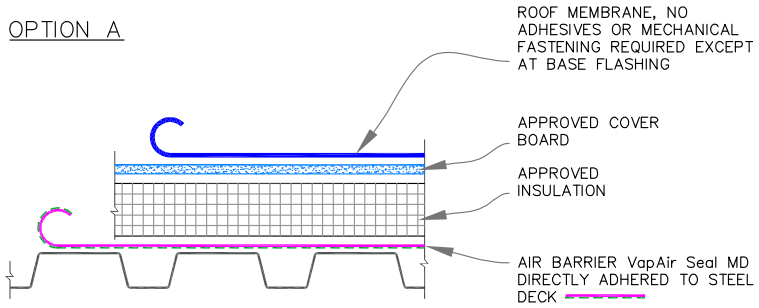

VacuSeal Vent Secured Roofing System

OPTION A

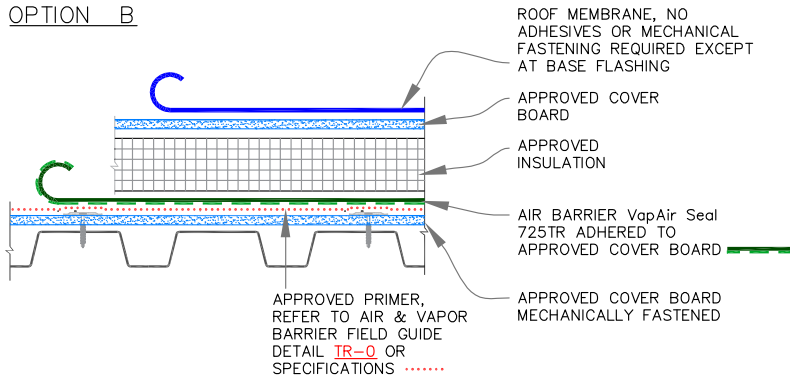

OPTION B



	ROOF ASSEMBLY OVER STEEL DECK		DETAIL NO.
	MAXIMUM WARRANTY: 20 YEARS		V-0.3

© 2023 Carlisle SynTec a division of Carlisle Construction Materials Incorporated

VacuSeal Vent Secured Roofing System

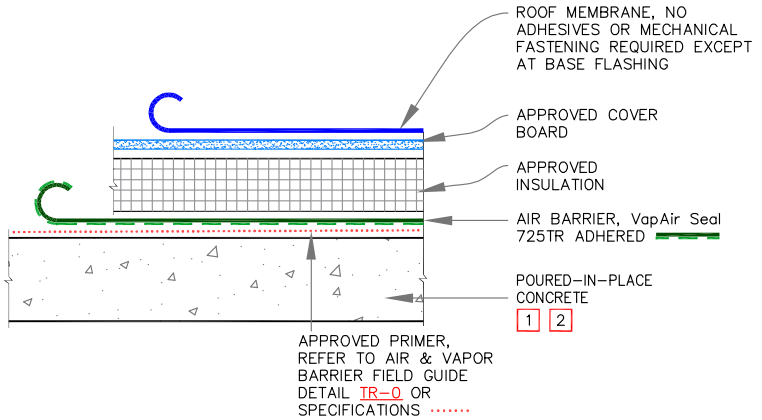

NOTES:

1. THE SUBSTRATE MAY NOT REQUIRE AN ADDITIONAL LAYER OF AIR BARRIER. TO ENSURE THAT A CONTINUOUS AIR-SEAL IS PROVIDED, THE SUBSTRATE MUST BE INSPECTED FOR BREACHES FOR AIR INFILTRATION AT CRACKS, JOINTS, PENETRATIONS, ROOF EDGES, PARAPET WALLS, AND SIMILAR CONDITIONS.

	ROOF ASSEMBLY OVER POURED-IN-PLACE CONCRETE DECK		DETAIL NO.
	MAXIMUM WARRANTY: 20 YEARS		V-0.4

© 2023 Carlisle SynTec a division of Carlisle Construction Materials Incorporated

VacuSeal Vent Secured Roofing System

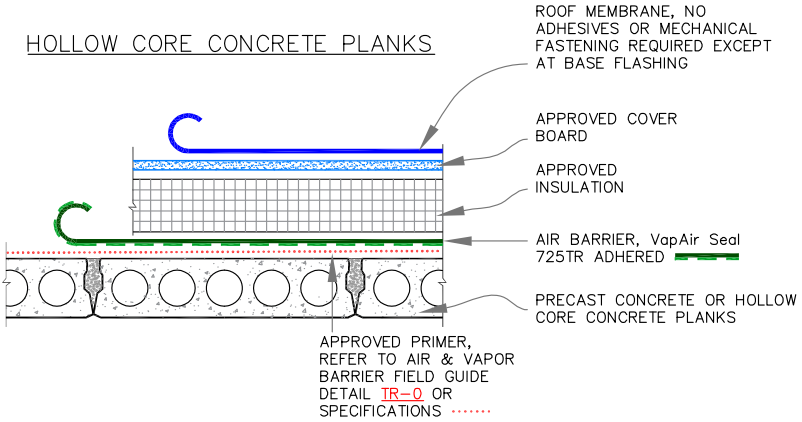

HOLLOW CORE CONCRETE PLANKS WITH TOPPING

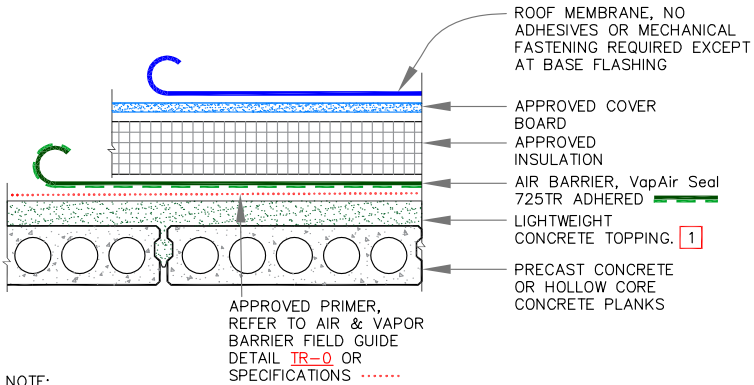

NOTE:

1. THE SUBSTRATE MAY NOT REQUIRE AN ADDITIONAL LAYER OF AIR BARRIER WHEN CONCRETE TOPPING EXISTS. TO ENSURE THAT A CONTINUOUS AIR-SEAL IS PROVIDED, THE SUBSTRATE MUST BE INSPECTED FOR BREACHES FOR AIR INFILTRATION AT CRACKS, JOINTS, PENETRATIONS, ROOF EDGES, PARAPET WALLS, AND SIMILAR CONDITIONS & PROPER REPAIRS MUST BE PERFORMED.

	ROOF ASSEMBLY OVER CONCRETE PLANKS		DETAIL NO.
	MAXIMUM WARRANTY: 20 YEARS		V-0.5

© 2023 Carlisle SynTec a division of Carlisle Construction Materials Incorporated

VacuSeal Vent Secured Roofing System

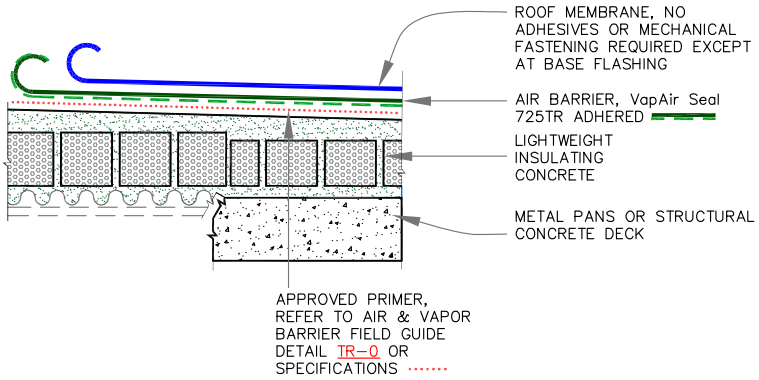

NOTE:

1. THE SUBSTRATE MAY NOT REQUIRE AN ADDITIONAL LAYER OF AIR BARRIER WHEN CONCRETE TOPPING EXISTS. TO ENSURE THAT CONCRETE SUBSTRATE PROVIDES A CONTINUOUS AIR-SEAL, THE SUBSTRATE MUST BE INSPECTED FOR AIR INFILTRATION. INSPECT FOR BREACHES CRACKS, JOINTS, PENETRATIONS, ROOF EDGES, PARAPET WALLS JUNCTIONS, AND SIMILAR CONDITIONS. PROPER REPAIRS MUST BE PERFORMED TO CREATE AN AIR BARRIER.

	ROOF ASSEMBLY OVER LIGHTWEIGHT CONCRETE DECK		DETAIL NO.
	MAXIMUM WARRANTY: 20 YEARS		V-0.6

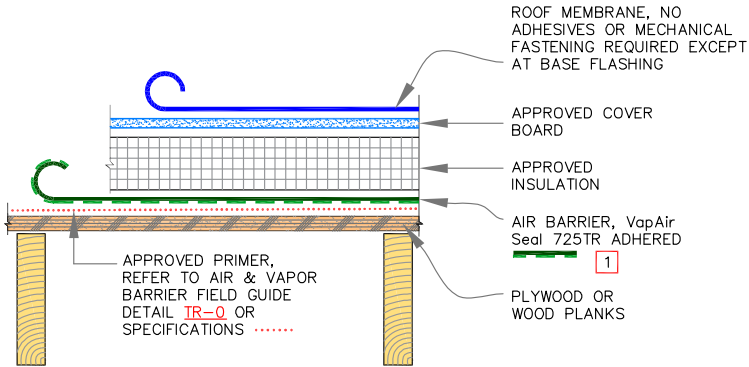

© 2023 Carlisle SynTec a division of Carlisle Construction Materials Incorporated

VacuSeal Vent Secured Roofing System



NOTES:

1. TO AVOID POTENTIAL DAMAGE TO AIR AND VAPOR BARRIER, PROTRUDING NAILS/FASTENERS SHALL BE REMOVED AND REPLACED WITH HEAVY GAUGE THREADED FASTENERS.
2. AS AN OPTION, THE AIR AND VAPOR BARRIER MAY BE ADHERED TO MECHANICALLY FASTENED SECURROCK OR DensDeck PRIME COVER BOARD.

	ROOF ASSEMBLY OVER WOOD DECK		DETAIL NO.
	MAXIMUM WARRANTY: 20 YEARS		V-0.7

© 2023 Carlisle SynTec a division of Carlisle Construction Materials Incorporated

VacuSeal Vent Secured Roofing System

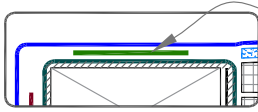

IN LIEU OF BONDING ADHESIVE, 3" (7.5cm) WIDE SecurTAPE MAY BE USED WITH PRIMER TO SEAL BOTH THE MEMBRANES

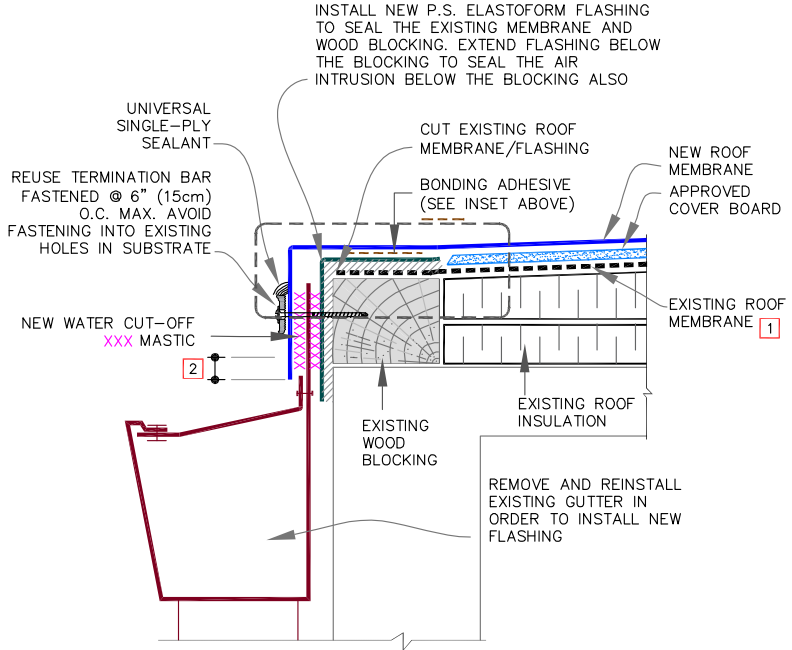

NOTES:

1. EXISTING ROOF MEMBRANE MAY BE USED AS AN AIR BARRIER. IT WILL REQUIRE THOROUGH INSPECTION FOR BREACHES, DAMAGES, AND AIR TIGHTNESS OF EXISTING FLASHING. SEAL ALL DEFICIENT CONDITIONS TO ACHIEVE AN AIRTIGHT AIR BARRIER.
2. ALLOW MEMBRANE SHEET TO EXTEND 1/2" (1.5cm) MINIMUM BELOW THE METAL TERMINATION BAR.

	ROOF EDGE: ROOF RECOVER		DETAIL NO.
	MAXIMUM WARRANTY: 20 YEARS		V-1.1

© 2023 Carlisle SynTec a division of Carlisle Construction Materials Incorporated

VacuSeal Vent Secured Roofing System

IN LIEU OF BONDING ADHESIVE,
3" (7.5cm) WIDE SecurTAPE
MAY BE USED WITH PRIMER TO
SEAL BOTH THE MEMBRANES

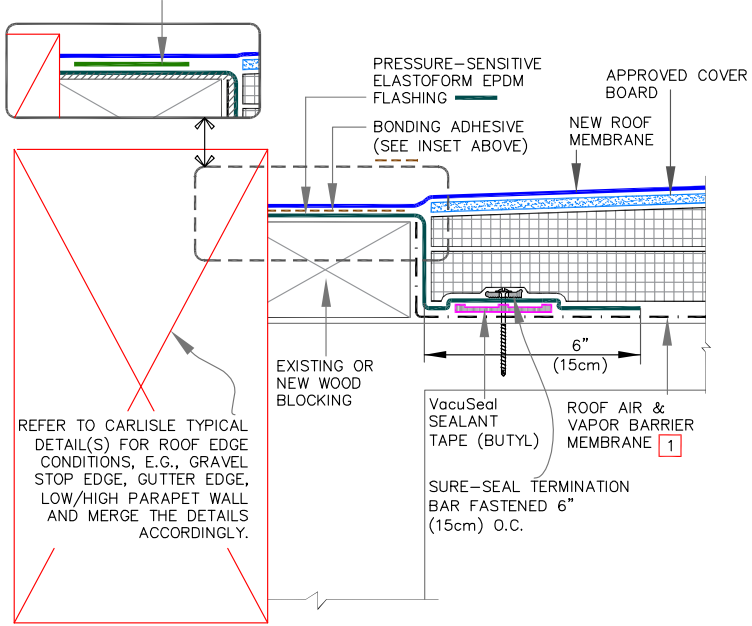

NOTES:

1. USE VapAir Seal 725TR AIR AND VAPOR BARRIER ON CONCRETE DECKS.
2. IN CASE OF METAL DECK, COORDINATE WITH CARLISLE.

	ROOF EDGE: TEAR-OFF & REROOFING		DETAIL NO.
	MAXIMUM WARRANTY: 20 YEARS		V-1.2

© 2023 Carlisle SynTec a division of Carlisle Construction Materials Incorporated

VacuSeal Vent Secured Roofing System

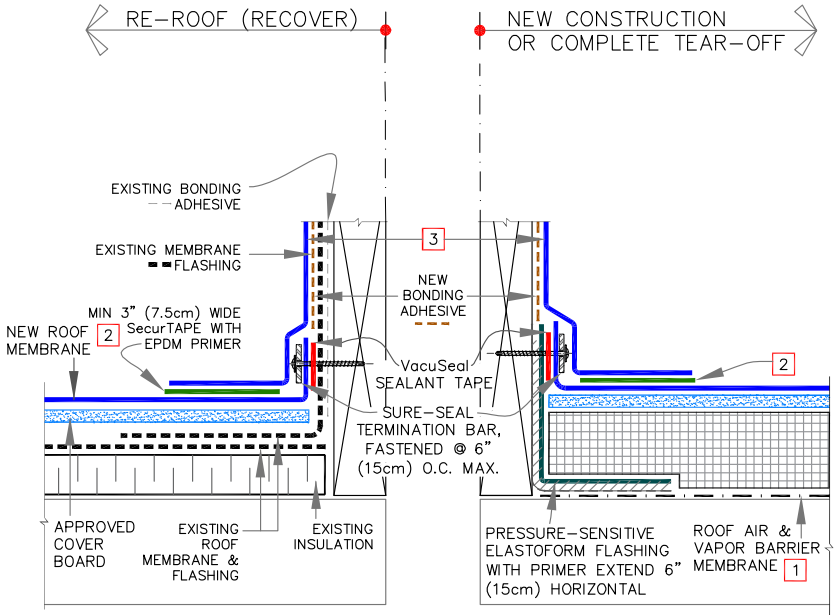

NOTES:

1. ON STEEL DECKS DIRECTLY ADHERE VapAir Seal MD. USE VapAir Seal 725TR ON CONCRETE & WOOD DECKS OR DECKS WITH APPROVED COVER BOARDS.
2. FOR ADDITIONAL INFORMATION, REFER TO CARLISLE'S THERMOSET DETAIL [U-5A](#) FOR EPDM AND THERMOPLASTIC DETAIL [U-5A](#) FOR TPO/PVC.
3. SELF-ADHERING EPDM CURB WRAP MAY BE SUBSTITUTED AS FLASHING ON EPDM ROOFS.

	CURB BASE FLASHING – NEW CONSTRUCTION AND RE-ROOF (RECOVER)		DETAIL NO.
	MAXIMUM WARRANTY: 20 YEARS		V-5.1

© 2023 Carlisle SynTec a division of Carlisle Construction Materials Incorporated

VacuSeal Vent Secured Roofing System

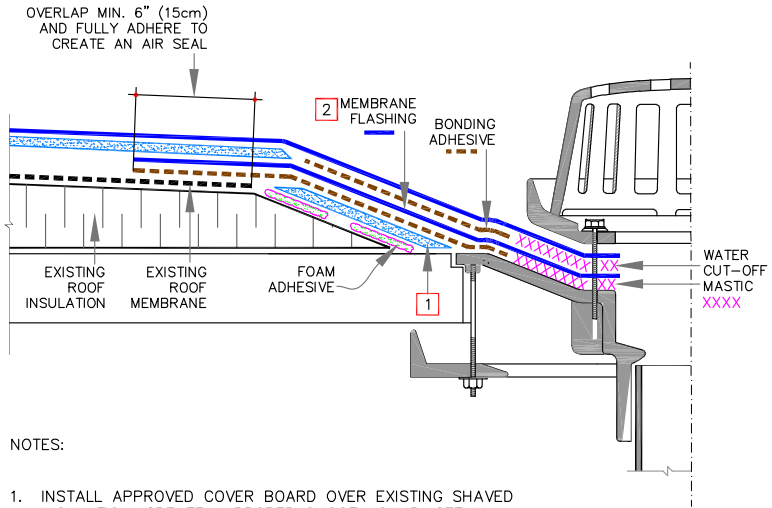

NOTES:

1. INSTALL APPROVED COVER BOARD OVER EXISTING SHAVED INSULATION. CREATE A PROPER SMOOTH SUMP. SET IN FOAM ADHESIVE.
2. FULLY ADHERE MEMBRANE FLASHING TO ACHIEVE AIRTIGHT CONDITION BETWEEN DRAIN AND EXISTING ROOF MEMBRANE. WHERE THERE IS EXISTING ROOF VAPOR BARRIER, CUT IT BACK, IN ORDER TO PROPERLY AIR SEAL.
3. FOR ADDITIONAL INFORMATION, REFER TO CARLISLE'S THERMOSET DETAIL [U-6](#) FOR EPDM AND THERMOPLASTIC DETAIL [U-6](#) FOR TPO/PVC.

	ROOF DRAIN: RE-ROOF (RECOVER)		DETAIL NO.
	MAXIMUM WARRANTY: 20 YEARS		V-6.1

© 2023 Carlisle SynTec a division of Carlisle Construction Materials Incorporated

VacuSeal Vent Secured Roofing System

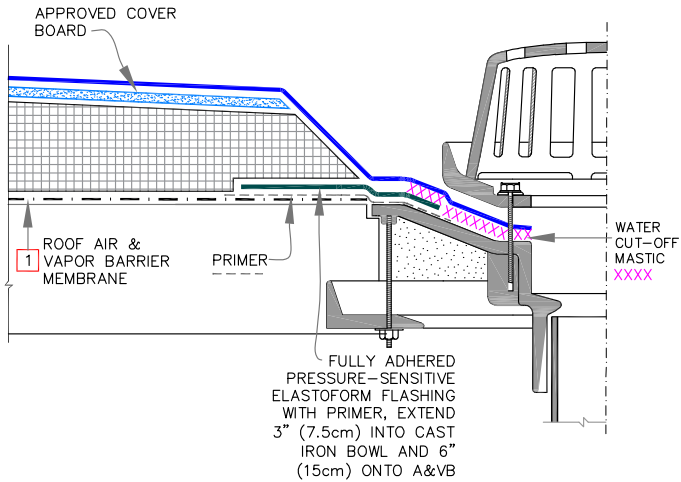

NOTES:

1. PROJECTS WITH STEEL DECKS, DIRECTLY ADHERE VapAir Seal MD. USE VapAir Seal 725TR ON CONCRETE, WOOD DECKS OR DECKS WITH APPROVED COVER BOARDS.
2. FOR ADDITIONAL INFORMATION, REFER TO CARLISLE'S THERMOSET DETAIL [U-6](#) FOR EPDM AND THERMOPLASTIC DETAIL [U-6](#) FOR TPO/PVC.

	ROOF DRAIN: NEW CONSTRUCTION		DETAIL NO.
	MAXIMUM WARRANTY: 20 YEARS		V-6.2

© 2023 Carlisle SynTec a division of Carlisle Construction Materials Incorporated

VacuSeal Vent Secured Roofing System

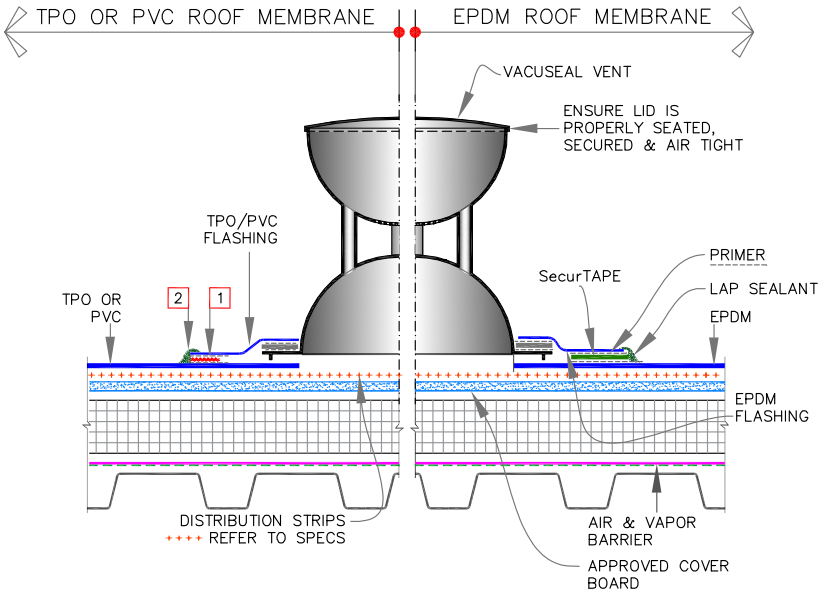

NOTES:

1. HOT AIR WELD, MIN. 1-1/2" (4cm).
2. APPROXIMATELY 1/8" (0.5cm) DIAMETER BEAD OF CUT-EDGE SEALANT IS REQUIRED ON CUT EDGES OF REINFORCED TPO MEMBRANE.

	VACUSEAL VENT WITH PRE-APPLIED SKIRT FLASHING		DETAIL NO.
	MAXIMUM WARRANTY: 20 YEARS		V-8.0

VacuSeal Vent Secured Roofing System

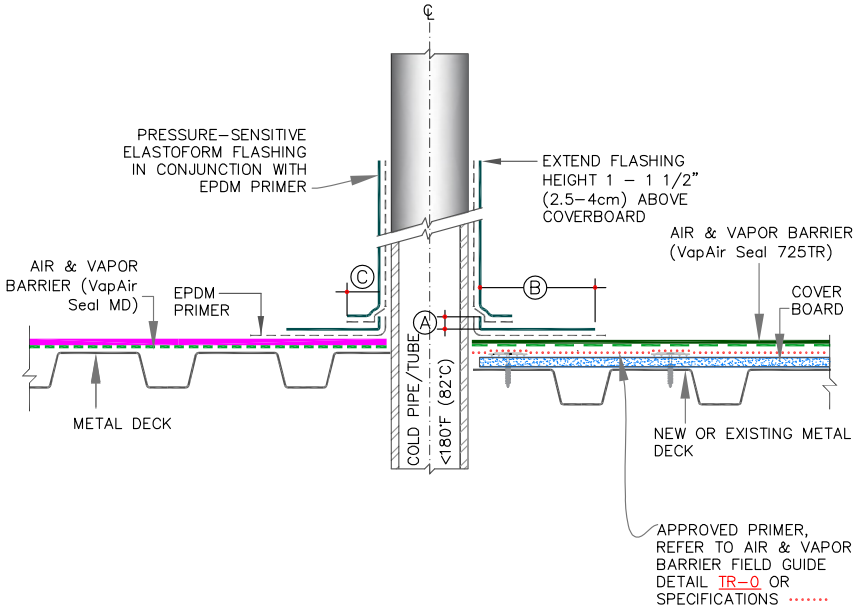

NOTE:

1. FOR ADDITIONAL INFORMATION, REFER TO CARLISLE THERMOSET DETAIL [U-8B](#).

DIMENSIONS	cm	
(A)	1/2"	1.5 MIN.
(B)	5.5"	14 MIN.
(C)	1"	2.5 MIN.

	PIPE/STRUCTURAL STEEL TUBE THROUGH METAL DECK		DETAIL NO.
	MAXIMUM WARRANTY: 20 YEARS		V-8.1

© 2023 Carlisle SynTec a division of Carlisle Construction Materials Incorporated

VacuSeal Vent Secured Roofing System

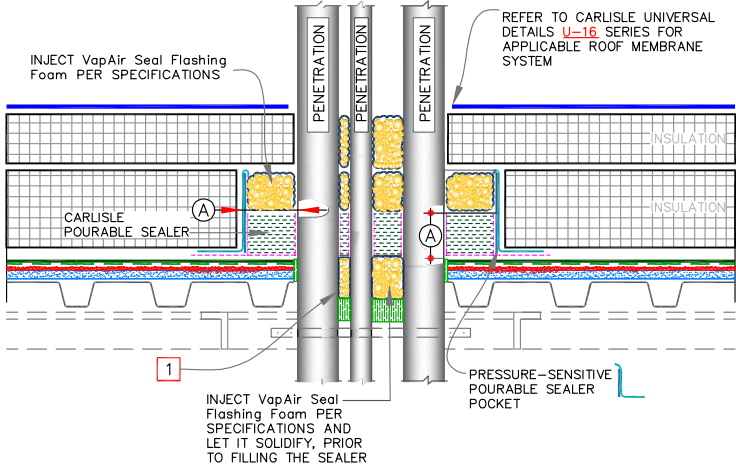

DIMENSIONS		cm	
A	1/2"	1.5	TO
	1"	2.5	

NOTES:

1. THE MAXIMUM ALLOWABLE SURFACE TEMPERATURE OF THE PENETRATION SHALL NOT EXCEED 180° F (82° C).
2. PENETRATIONS, AIR & VAPOR BARRIER, FLASHING AND METAL (INSIDE POCKET) MUST BE PRIMED WITH EPDM PRIMER PRIOR TO APPLYING POURABLE SEALER. DO NOT PRIME THE BLUE PLASTIC SUPPORT STRIP.
3. POURABLE SEALER MUST CONTACT PRIMED PRESSURE-SENSITIVE ELASTOFORM FLASHING AND AIR & VAPOR BARRIER.
4. PIPE CLUSTERS MUST HAVE MINIMUM 1" (2.5cm) CLEARANCE BETWEEN PENETRATIONS.

	MULTIPLE PENETRATIONS THROUGH STEEL DECK – NEW CONSTRUCTION		DETAIL NO.
	MAXIMUM WARRANTY: 20 YEARS		V-8.2

© 2023 Carlisle SynTec a division of Carlisle Construction Materials Incorporated

VacuSeal Vent Secured Roofing System

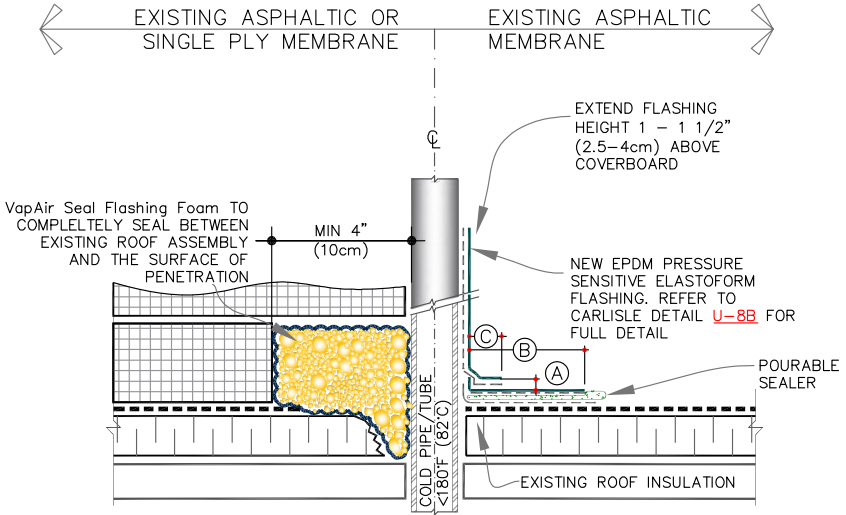

DIMENSIONS	cm	
(A)	1/2"	1.5 MIN.
(B)	5.5"	14 MIN.
(C)	1"	2.5 MIN.

	SINGLE PENETRATION THROUGH EXISTING ROOF ASSEMBLY		DETAIL NO.
	MAXIMUM WARRANTY: 20 YEARS		V-8.3



© 2023 Carlisle SynTec a division of Carlisle Construction Materials Incorporated

VacuSeal Vent Secured Roofing System

NOTES:

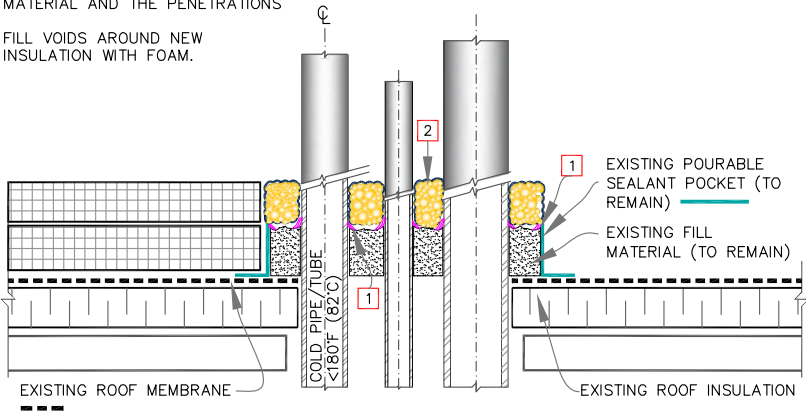
1. APPLY NEW SEALANT AT ALL CRACKED AND BREACHED AREAS OF POURABLE SEALERS. ENSURE A PROPER BOND BETWEEN EXISTING MATERIAL AND THE PENETRATIONS
2. FILL VOIDS AROUND NEW INSULATION WITH FOAM.



	CLUSTER OF PENETRATIONS THROUGH EXISTING ROOF ASSEMBLY		DETAIL NO.
	MAXIMUM WARRANTY: 20 YEARS		V-8.4

© 2023 Carlisle SynTec a division of Carlisle Construction Materials Incorporated

VacuSeal Vent Secured Roofing System

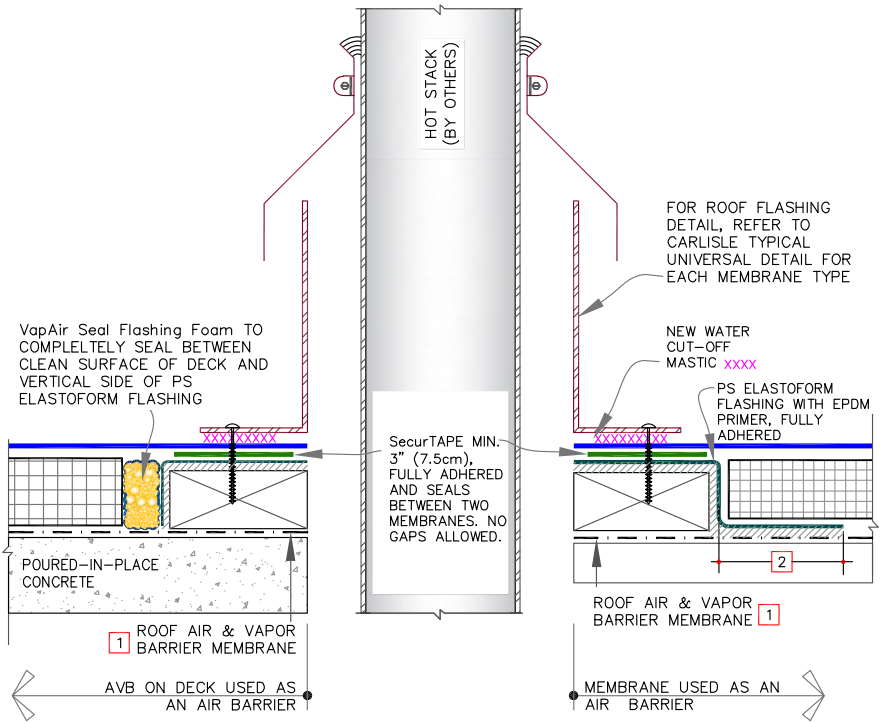

NOTES:

1. ON STEEL DECKS DIRECTLY ADHERE VapAir Seal MD. USE VapAir Seal 725TR ON CONCRETE & WOOD DECKS OR DECKS WITH APPROVED COVER BOARDS.
2. OVERLAP MIN. 6" (15cm) AND FULLY ADHERE TO CREATE AN AIR SEAL.

	HOT STACK AIR FLASHING – OPTION A		DETAIL NO.
	MAXIMUM WARRANTY: 20 YEARS		V-8.5A

© 2023 Carlisle SynTec a division of Carlisle Construction Materials Incorporated

VacuSeal Vent Secured Roofing System

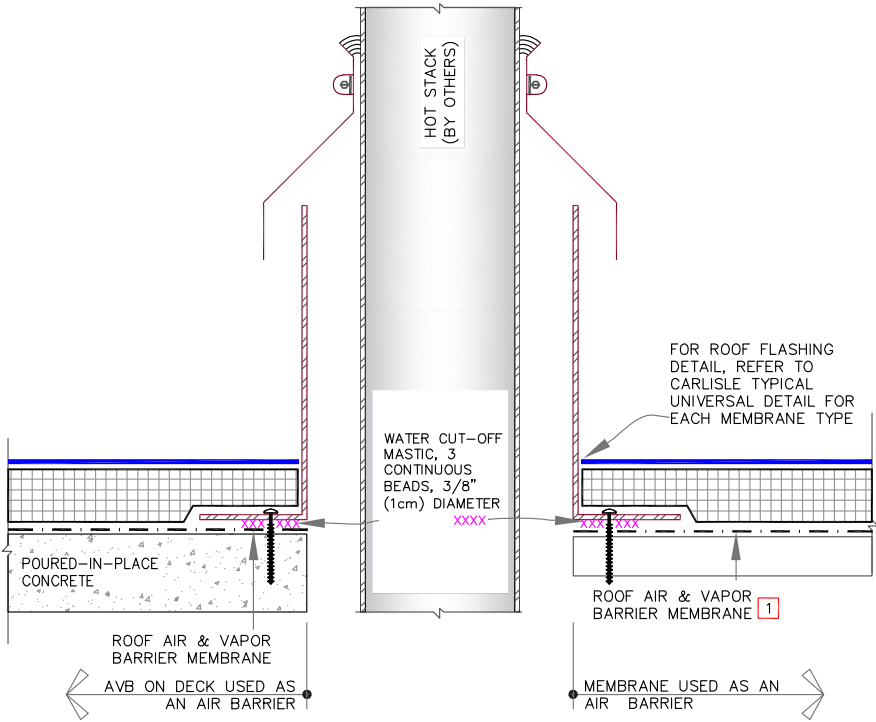

NOTES:

- ON STEEL DECKS DIRECTLY ADHERE VapAir Seal MD. USE VapAir Seal 725TR ON CONCRETE & WOOD DECKS OR DECKS WITH APPROVED COVER BOARDS.

	HOT STACK AIR FLASHING – OPTION B		DETAIL NO.
	MAXIMUM WARRANTY: 20 YEARS		V-8.5B

© 2023 Carlisle SynTec a division of Carlisle Construction Materials Incorporated

VacuSeal Vent Secured Roofing System

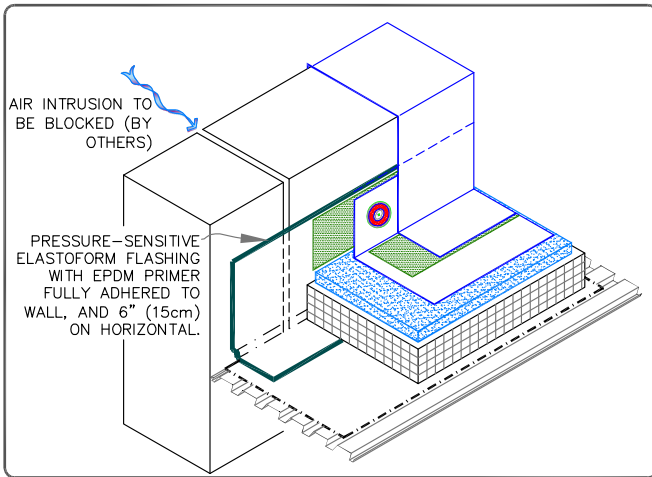
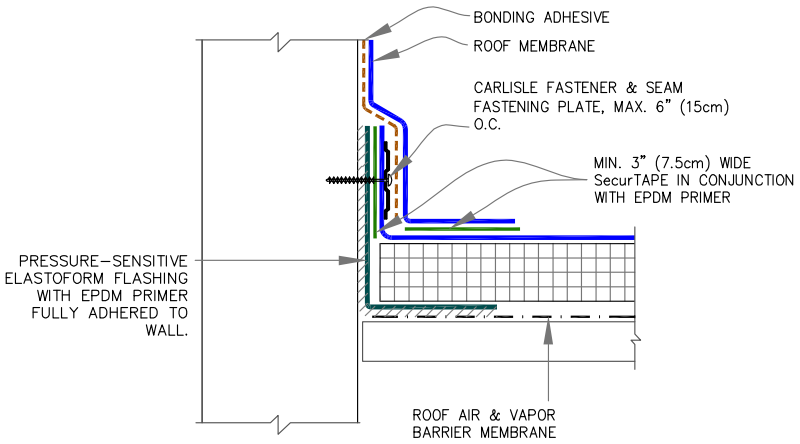

	PARAPET WITH MEMBRANE AIR BARRIER		DETAIL NO.
	MAXIMUM WARRANTY: 20 YEARS		V-12.1

© 2023 Carlisle SynTec a division of Carlisle Construction Materials Incorporated

VacuSeal Vent Secured Roofing System

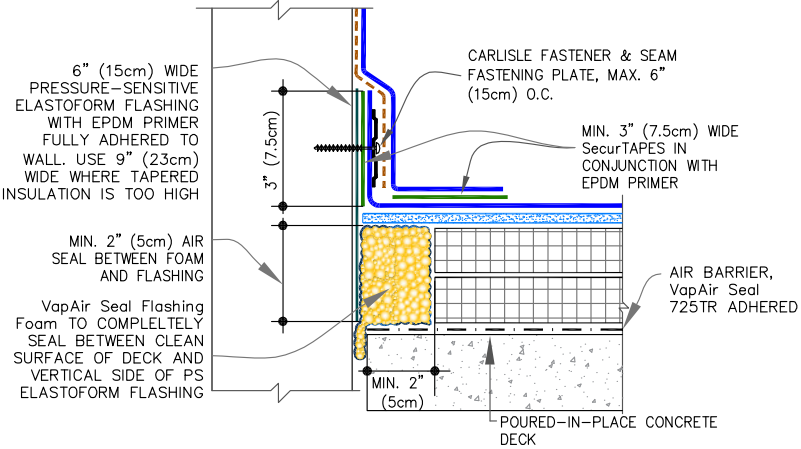

(A) OPTION: AIR SEALING WITH FOAM

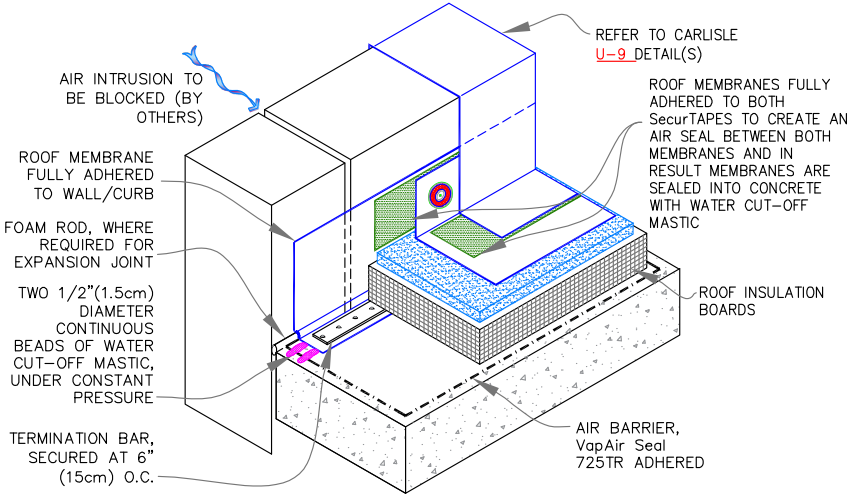

(B) OPTION: AIR SEALING WITH MEMBRANE FLASHING

	PARAPET / CURB: CONCRETE/LIGHTWEIGHT CONCRETE WITH DECK LEVEL AIR/VAPOR BARRIER		DETAIL NO.
	MAXIMUM WARRANTY: 20 YEARS		V-12.2

(C) 2023 Carlisle SynTec a division of Carlisle Construction Materials Incorporated

VacuSeal Vent Secured Roofing System

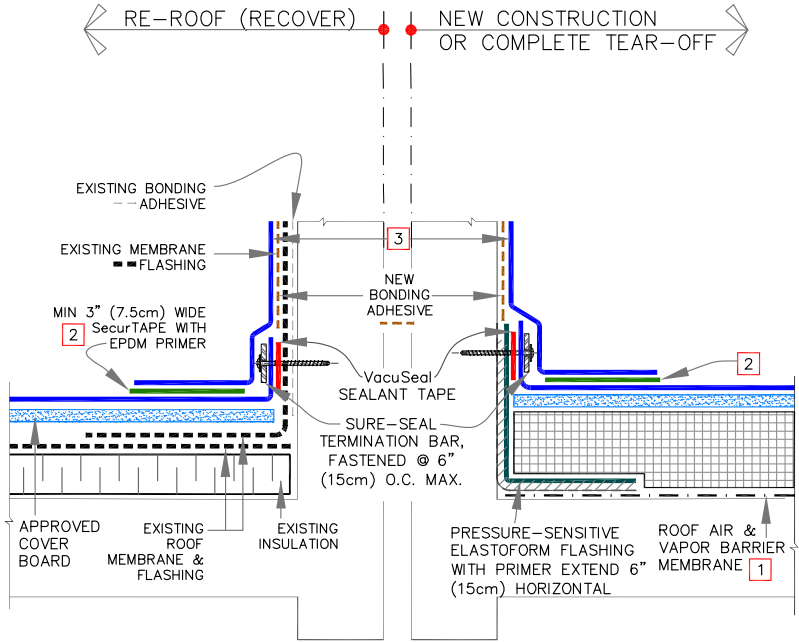

NOTES:

1. ON STEEL DECKS DIRECTLY ADHERE VapAir Seal MD. USE VapAir Seal 725TR ON CONCRETE & WOOD DECKS OR DECKS WITH APPROVED COVER BOARDS.
2. FOR ADDITIONAL INFORMATION, REFER TO CARLISLE'S THERMOSET DETAIL [U-5A](#) FOR EPDM AND THERMOPLASTIC DETAIL [U-5A](#) FOR TPO/PVC.
3. SELF-ADHERING EPDM CURB WRAP MAY BE SUBSTITUTED AS FLASHING ON EPDM ROOFS.

	PARAPET OR WALL — NEW CONSTRUCTION AND RE-ROOF (RECOVER)		DETAIL NO.
	MAXIMUM WARRANTY: 20 YEARS		V-12.3

© 2023 Carlisle SynTec a division of Carlisle Construction Materials Incorporated

800-479-6832 • www.carlisesyntec.com

Carlisle, FleeceBACK, Sure-Weld, Sure-Seal, Sure-Tough, Sure-White, VacuSeal, SAT, SecurShield, Insulbase, InsulLam, Stormbase, ChannelDry, EcoStorm VSH, HP-X Fastener, Insulfast, Piranha Plate, SecurFast, FAST, FAT, UN-TACK, SecurTAPE, CAV-GRIP, Elastoform Flashing, VapAir Seal, X-Tenda Coat, and SecurEdge are trademarks of Carlisle. R-Tech is a registered trademark of Insulfoam. SECUROCK is a registered trademark of USG Corporation. GALVALUME is a registered trademark of BEIC International, Inc. DensDeck is a registered trademark of Georgia-Pacific Gypsum LLC. Kynar 500 is a registered trademark of Arkema, Inc. LEED is a registered trademark of the U.S. Green Building Council.

© 2023 Carlisle. REPRINT CODE: 612067 CST-11374 - "EPDM Field Guide" - 08.24.23