

NOTES:

1. WOOD NAILERS ARE INSTALLED ONLY AT SCUPPERS TO SECURE METAL SLEEVE AND MUST EXTEND PAST THE WIDTH OF METAL SLEEVE FLANGE.
2. METAL SCUPPER BOX MUST HAVE CONTINUOUS FLANGES WITH ROUNDED CORNERS, SOLDER ALL SCUPPER SEAMS WATER-TIGHT.
3. WATER CUT-OFF MASTIC UNDER SCUPPER FLANGE MUST BE UNDER CONSTANT COMPRESSION.
4. PRESSURE SENSITIVE COVER STRIP MUST EXTEND A MINIMUM 2" (5cm) COVERAGE PAST NAIL HEAD.
5. UNIVERSAL SINGLE-PLY SEALANT IS REQUIRED AT FLASHING EDGES ON SCUPPER EDGE. PVC STEP 2 PRIMER MUST BE USED TO PREPARE SURFACES PRIOR TO THE APPLICATION OF SEALANT.

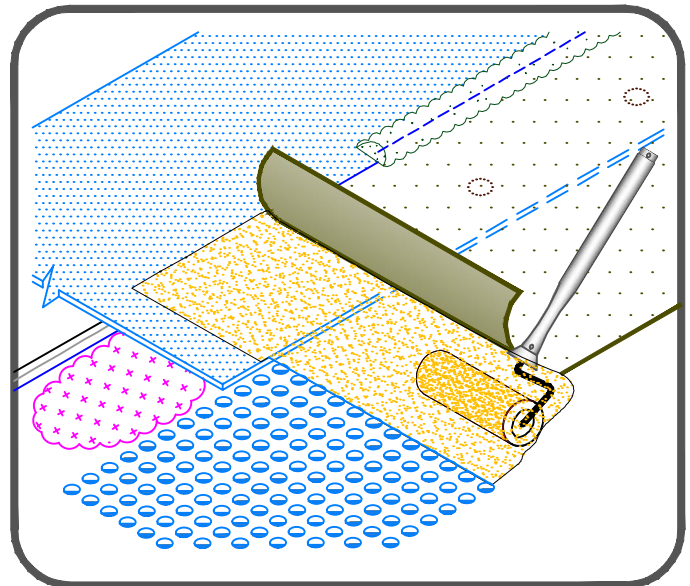

	SCUPPER WITH UNCOATED METAL – PRESSURE-SENSITIVE COVER STRIP PAGE 1 OF 2		DETAIL NO. U-18B
	MAXIMUM WARRANTY: 20 YEARS	U (Universal Detail)	

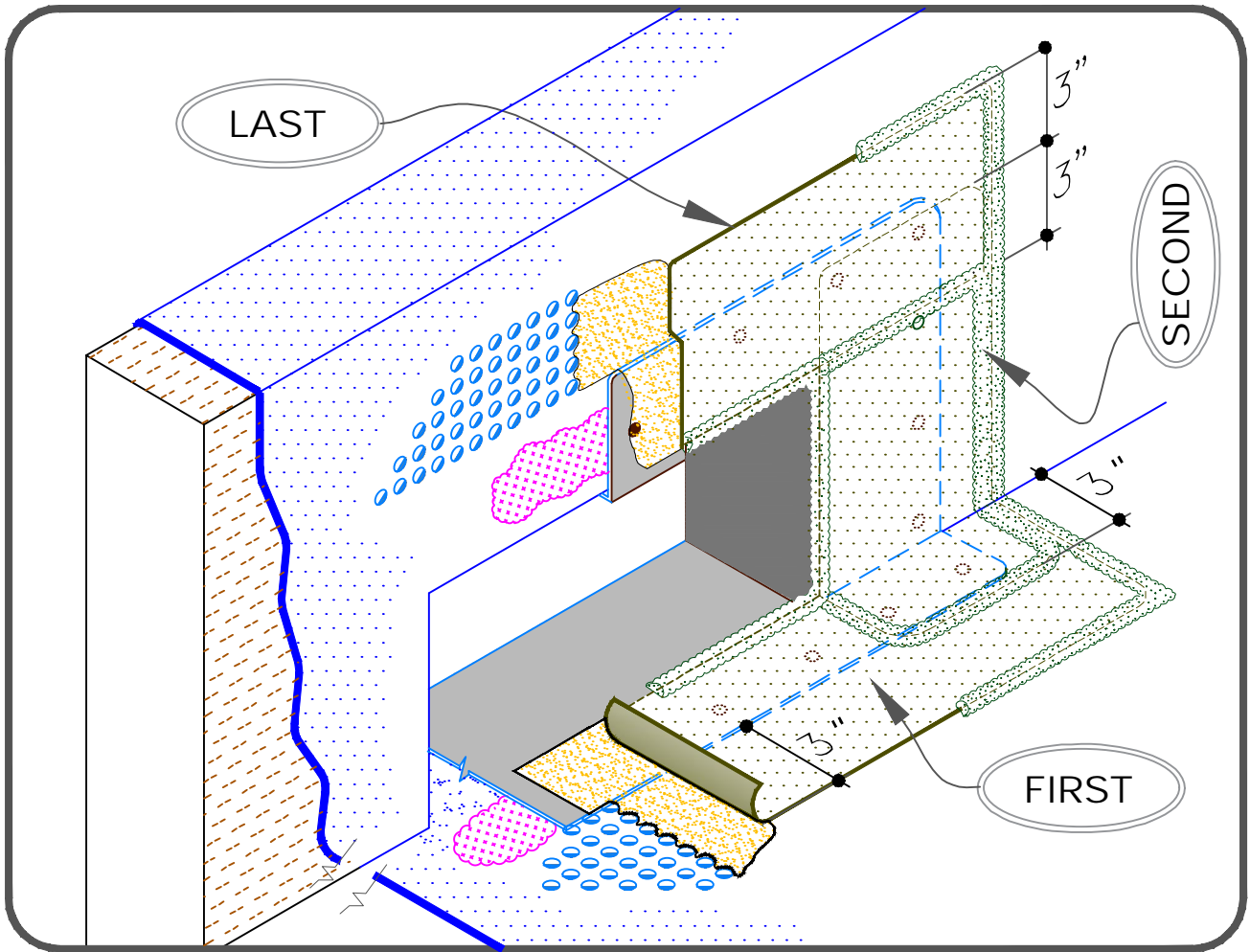

ISOMETRIC



SCUPPER WITH UNCOATED METAL –
PRESSURE-SENSITIVE COVER STRIP
PAGE 2 OF 2

MAXIMUM WARRANTY: 20 YEARS



DETAIL NO.

U- 18B

U (Universal Detail)