

ES-1 Contractor Certification Program

Carlisle SynTec Systems' ES-1 Contractor Certification Program is designed for Carlisle authorized applicators who want the capability and flexibility of fabricating their own ES-1 compliant edge metal. This program allows authorized applicators to fabricate ANSI-SPRI ES-1 certified edge trim utilizing Carlisle's existing test results, after completing a required third-party quality control audit.

Carlisle's ES-1 Contractor Certification Program requires an auditor to conduct an annual shop inspection of the contractor's fabrication site(s) and fabrication equipment. The cost of the yearly inspection is \$2,000 per location. Contractors who wish to apply for ES-1 contractor certification must receive approval by the appropriate Carlisle Regional Manager.

HOW TO GET APPROVED

1. Fill out the ES-1 Contractor Certification Request Form, available for download from the Carlisle website, and submit the completed form to your local Carlisle Manufacturer's Representative or Regional Manager.
2. Upon Regional Manager approval, the contractor will receive an invoice from Drexel Metals for the \$2,000 audit fee.
3. The contractor can elect to prepay the invoice or have a check ready at the time of the facility audit.
4. The facility audit will include a review of all equipment and fabrication of sample profiles as required by the auditor.
5. After successful completion of the audit, Carlisle will send the contractor a letter verifying their acceptance into the program, as well as a compliance certificate for specific profiles identifying them as an ES-1 Certified Fabricator.
6. Carlisle will send the contractor an electronic folder with all applicable dimensionalized drawings and details for the fabrication of ES-1 tested metal edging profiles.



BENEFITS OF ES-1 CERTIFICATION

- » Reduce liability by maintaining International Building Code (IBC) compliance
- » Leverage the certification to grow sales with certified, shop-fabricated, code-compliant edge metal
- » Achieve an edge-to-edge warranty on a Carlisle roof system (up to 20 yr, 72 mph)
- » Receive a 30-year paint finish warranty
- » Obtain project compliance certificates (issued upon request)

TIPS AND REMINDERS

1. Face pieces, cleats, and splice plates must be fabricated using Carlisle flat sheets, available from a local Carlisle distributor.
2. Prefabricated cleats are also available when needed.
3. Only the designs provided are ES-1 tested (see back of sheet).
4. ES-1 Certification must be renewed each year.
5. Certification by a non-Carlisle entity does not qualify for this program.

ES-1 CONTRACTOR CERTIFICATION PROGRAM

It is important to note that only details provided by Carlisle under this program are ES-1 tested and approved. Other designs or custom details may not be tested and would not qualify for approval under this program. This includes modifications to fastener type and placement. It is also important to remember that testing and compliance are based on use of Carlisle metal flat sheet material and other material may not qualify. Below are the details that have been ES-1 tested by CCM that an applicator in this program would be eligible to fabricate.

Coping

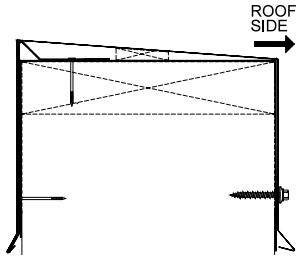

Snap Coping

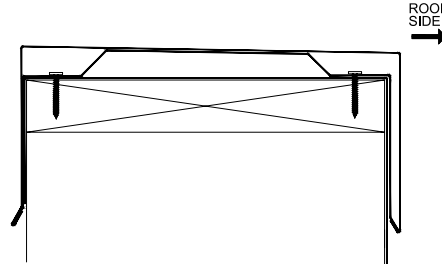

Snap Coping Max

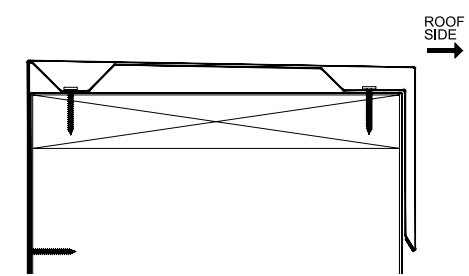

Fascia

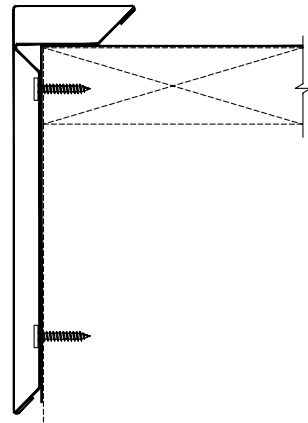

Fascia EC

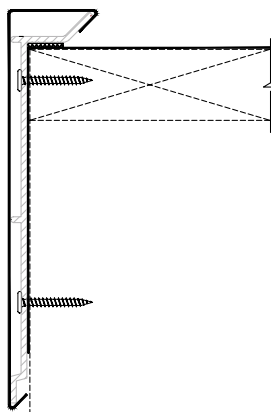

Drip Edge

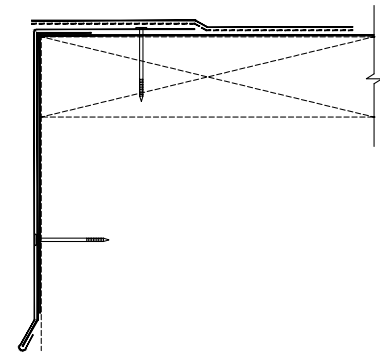

Spring-Tite Gravel Stop

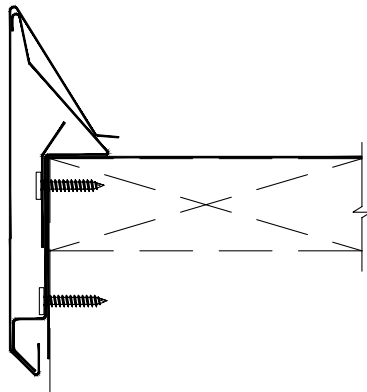

Snap-Lock Gravel Stop

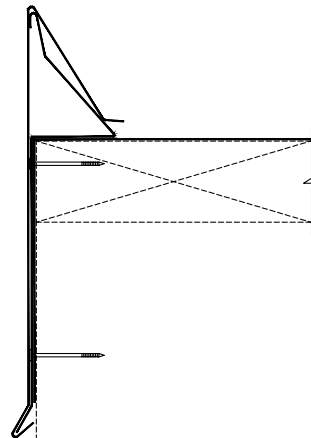

TPO/PVC Coated Drip Edge

